



THE DATASHEET OF APS00B



APS00B

High Resolution Magnetic Angular Position Sensor IC

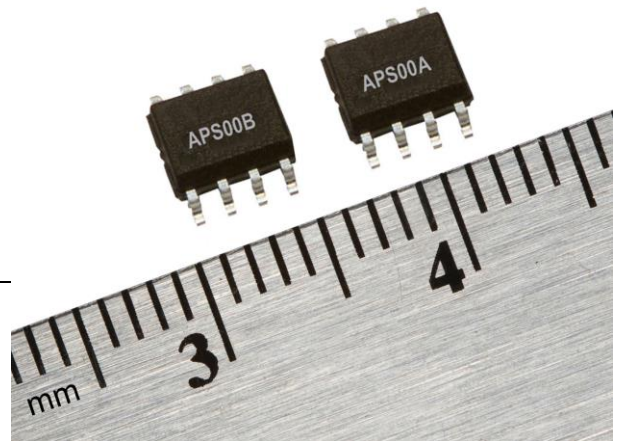

DESCRIPTION

Honeywell's APS00B High Resolution Magnetic Angular Position Sensor IC (Integrated Circuit) is a miniature surface mount device for angular or rotary displacement designed for magnetic saturating field sensing.

The APS00B creates an analog output voltage that varies with the direction of the magnetic flux passing over the IC surface. It contains dual saturated-mode Wheatstone bridges that generate quadrature (sine and cosine) signals to provide an extended range of angular measurements up to 180°.

This product is a cost-effective and space-efficient solution for high volume OEM designs. Potential applications include position sensing, rotary speed and angle detection, and non-contact precision location measurement systems.

FEATURES AND BENEFITS

- Wide angular range allows measurements of $\pm 90^\circ$ without additional components make this device suitable for a variety of angular sensing applications; $\pm 180^\circ$ measurement is possible with external components
- Resolution capability of less than 0.05° helps improve overall system accuracy
- Absolute sensing means no indexing is required and the exact target position is known, simplifying the system design
- Dual 4-element Wheatstone bridges provide a passive element, low-noise design, helping improve system performance
- Small, SOIC-8 surface mount package saves room on the PC board when compared to larger IC packages and components
- RoHS-compliant materials meet Directive 2002/95/EC
- Tape and reel configuration allows use with automated pick-and-place equipment, potentially reducing assembly costs. (178 mm [7 in]) and 330 mm [13 in] reels available)
- Typical 0 MHz to 5 MHz frequency response with 190 G minimum magnetic field applied, makes this saturated mode sensor IC potentially suitable for high speed applications
- Typically requires only 5 V at 4 mA to operate (20 mW), promoting energy efficiency
- The devices measure only field direction and are virtually unaffected by shock, vibration and magnetic-source gap variations, providing a stable, reliable output
- Dual bridges with outputs 45° out of phase make it possible to use outputs as speed and direction signals
- Honeywell APS00A instrumentation amplifier available for additional signal processing

APS00B

POTENTIAL APPLICATIONS

Transportation:

- High accuracy angular position sensing
- Rotary speed and angle detection
- Non-contact precision displacement sensing
- Speed and direction sensing

Medical:

- High accuracy angular position sensing
- Rotary speed and angle detection
- Non-contact precision displacement sensing

Industrial:

- High accuracy angular position sensing
- Rotary speed and angle detection
- Non-contact precision displacement sensing
- Valve position
- Robotics control

Table 1. Absolute Maximum Ratings*

Parameter	Min.	Max.	Unit
Supply voltage	-12	+12	V
Power Dissipation	–	200	mW
Operating Temperature	-55 [-67]	150 [302]	°C [°F]
Magnetic flux	–	no limit	Gauss



*Absolute maximum ratings are the extreme limits the device will withstand without damage to the device. However, the electrical and mechanical characteristics are not guaranteed as the maximum limits (above recommended operating conditions) are approached, nor will the device necessarily operate at absolute maximum ratings.

Table 2. Characteristics (At Vs = 5.0 V and Ta = 25 °C [77 °F] unless otherwise noted.)

Parameter	Condition	Min.	Typ.	Max.	Unit
Supply voltage	–	–	5	12	V
Operating Temperature	–	-40 [-40]	–	150 [302]	°C [°F]
Bridge resistance	bridges are connected in parallel	0.9	1.25	1.6	kOhm
Supply current	–	–	4.0	7.0	mA
Sensitivity	around zero crossing	–	2.1	2.3	mV/°
Angle range	B > saturation field	-90	–	+90	°
Resolution	–	–	0.05	–	°
Max. output amplitude	–	47.5	57.5	67.5	mV
Min. output amplitude	–	-47.5	-57.5	-67.5	mV
Output amplitude (peak to peak)	–	95	115	135	mV
Offset voltage	–	-1	–	1	mV
Amplitude change	at 140°C [284°F]	-34	–	-43	%
Amplitude change	at -40°C [-40 °F]	24	–	31	%
Offset shift	–	-2	–	2	mV
Synchronism	(Amp A/Amp B) * 100	97	–	103	%
Synchronism shift	–	-1	–	1	%
Saturation level	<10 µV/Gauss amplitude change	60	190	–	Gauss
Bandwidth	–	0 to 5.0			MHz

High Resolution Magnetic Angular Position Sensor IC

Figure 1. Detection of Relative Motion of a Magnet in Angular Displacement

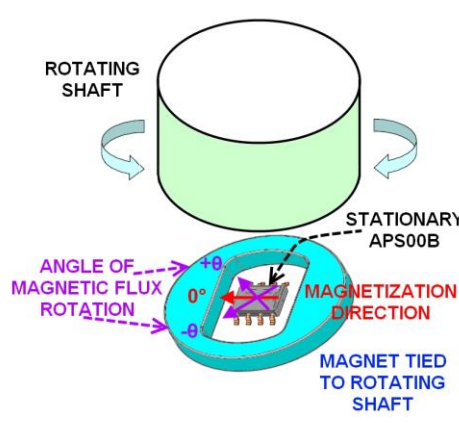

The APS00B sensor can be used to detect the relative motion of a magnet in angular displacement.

Given a typical supply voltage of 5 V, each bridge will provide about 115 mV of swing (± 57.5 mV) on top of 2.5 V bias voltage. With +5 V applied to it, the bridge performs a rail splitter function to create two near +2.5 V sources driven apart by ΔV as created by the magnetic field and the offset error voltage.

The bridge differential output voltages (ΔV) for the APS00B are:
 $\Delta V_A = V_s S \sin(2\theta)$ and $\Delta V_B = V_s S \cos(2\theta)$ where:
 V_s = Supply Voltage (V)
 S = Material Constant = $(\Delta R/R_{max}) * (1/2) = 11.5$ mV/V nominal
 θ = Reference to Magnetic Field Angle ($^\circ$)

Please refer to Application Sheet ["How to Apply Honeywell APS00B Angular Position Sensors ICs"](#) for additional details.

Figure 2. Electrical Diagram

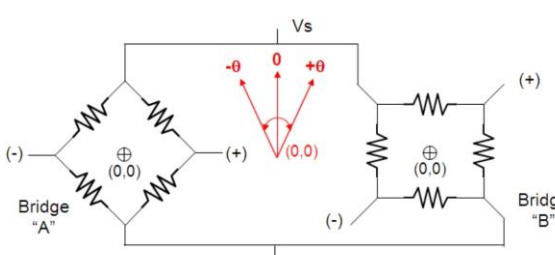

Bridge "A" output:
 $V_{outA} = V_s * S * \sin(2\theta) + V_{osA}$
 where:
 $S = 11.5$ mV/V nominal
 V_{osA} = Bridge A Offset (nominal = 0 V)

Bridge "B" output:
 $V_{outB} = V_s * S * \cos(2\theta) + V_{osB}$
 where:
 $S = 11.5$ mV/G nominal
 V_{osB} = Bridge B Offset (nominal = 0 V)

Bridge A is centroidally co-located with Bridge B, and Bridge A elements are rotated by 45° relative to Bridge B elements as shown.

Figure 3. Pinout and Sensing Element Location

The APS00B has two sensor bridges optimized for rotary sensing applications. Thus the die is centered in all three dimensions within the SOIC-8 package. The figure below indicates the pin identification and the sensing element location.

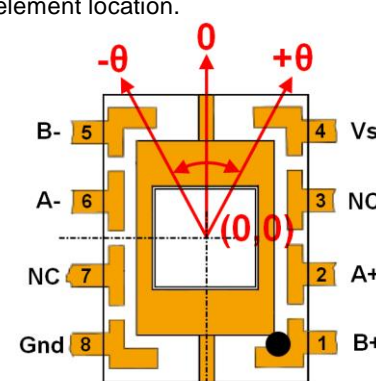
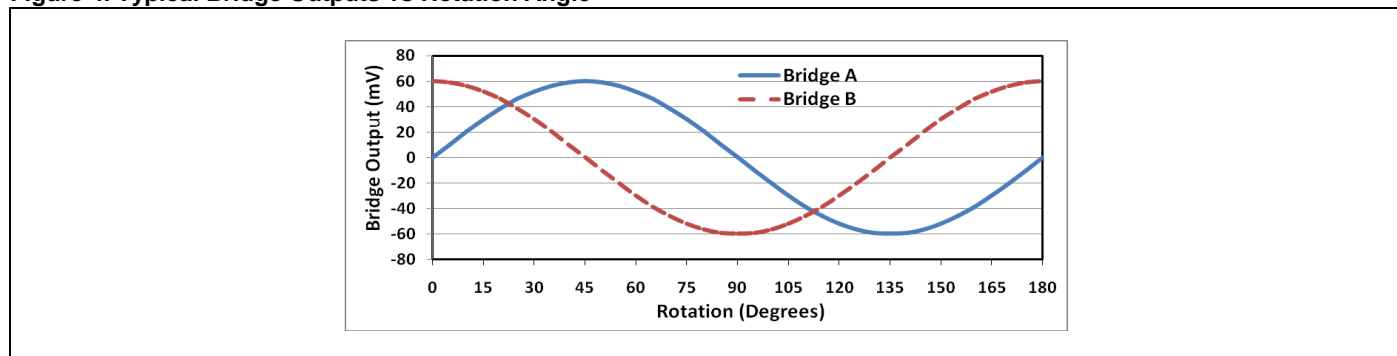

Figure 4. Typical Bridge Outputs vs Rotation Angle



APS00B

Figure 5. Common Wiring Diagrams

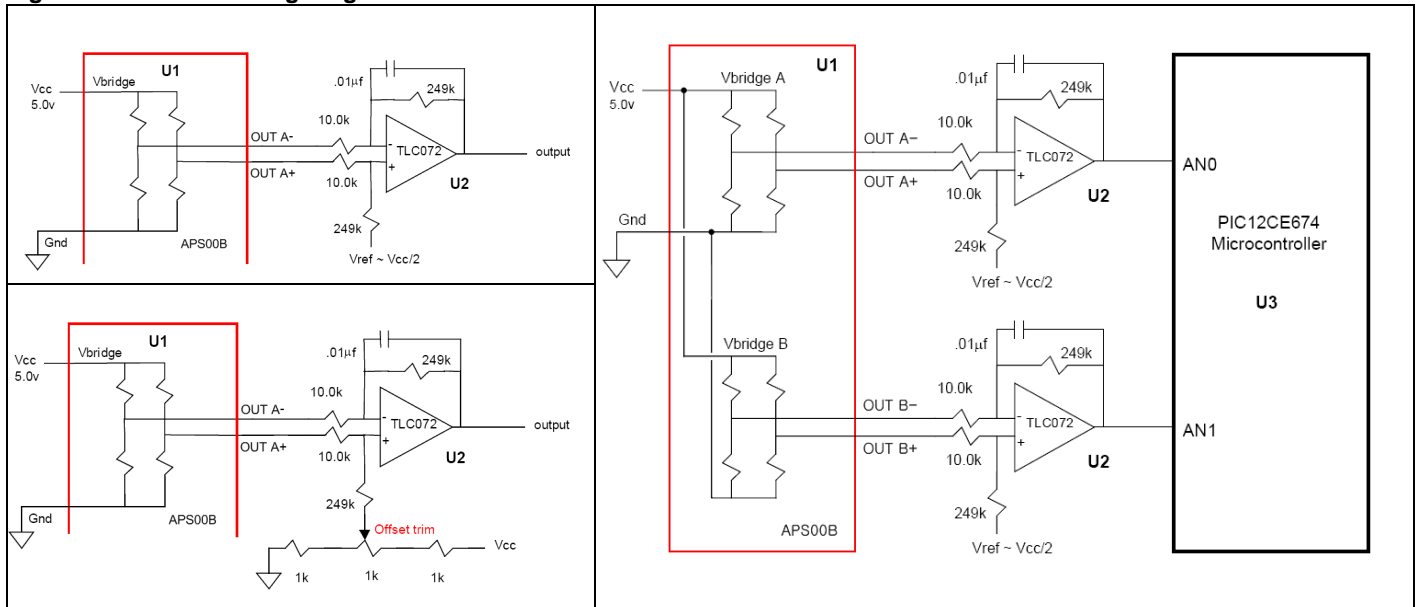
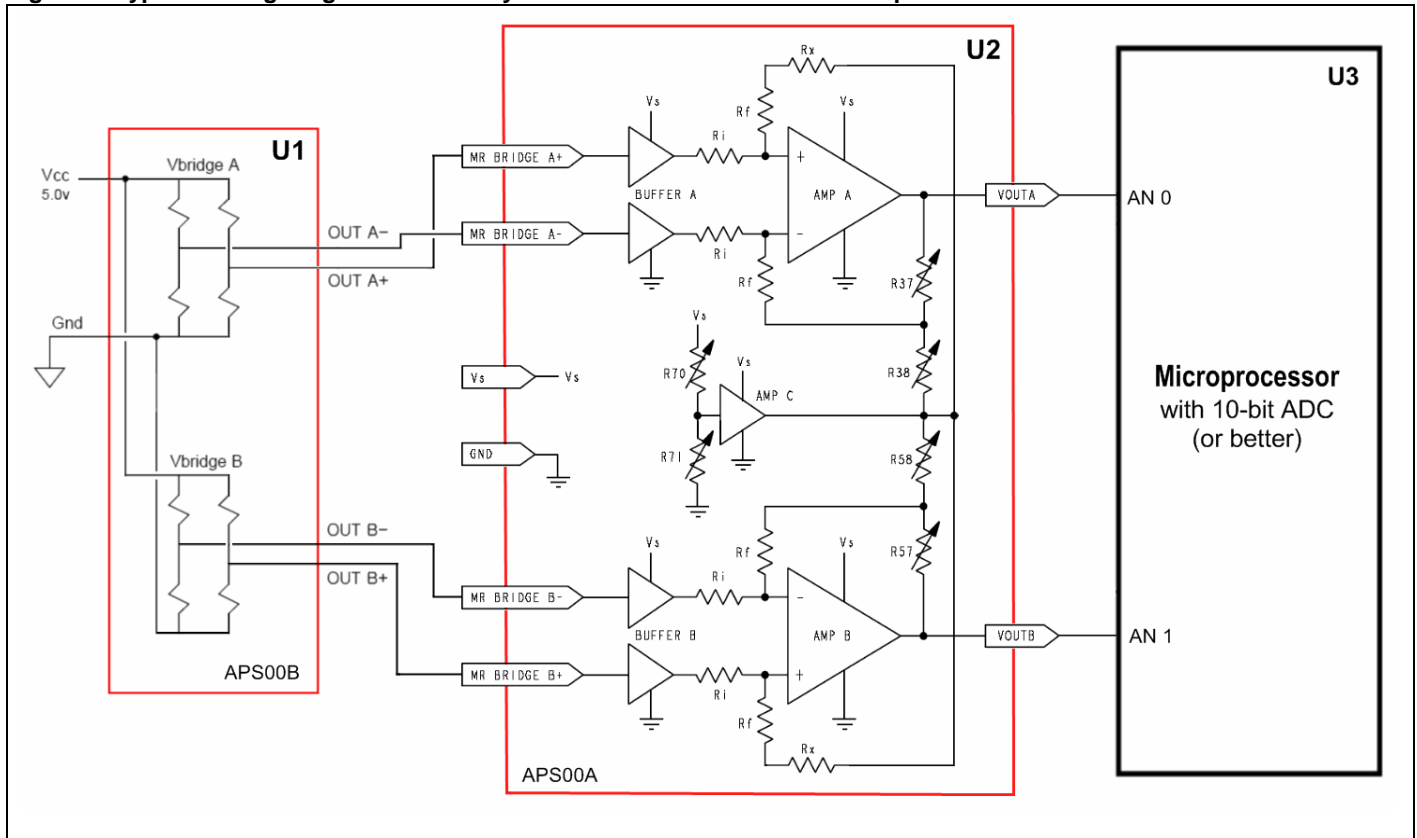
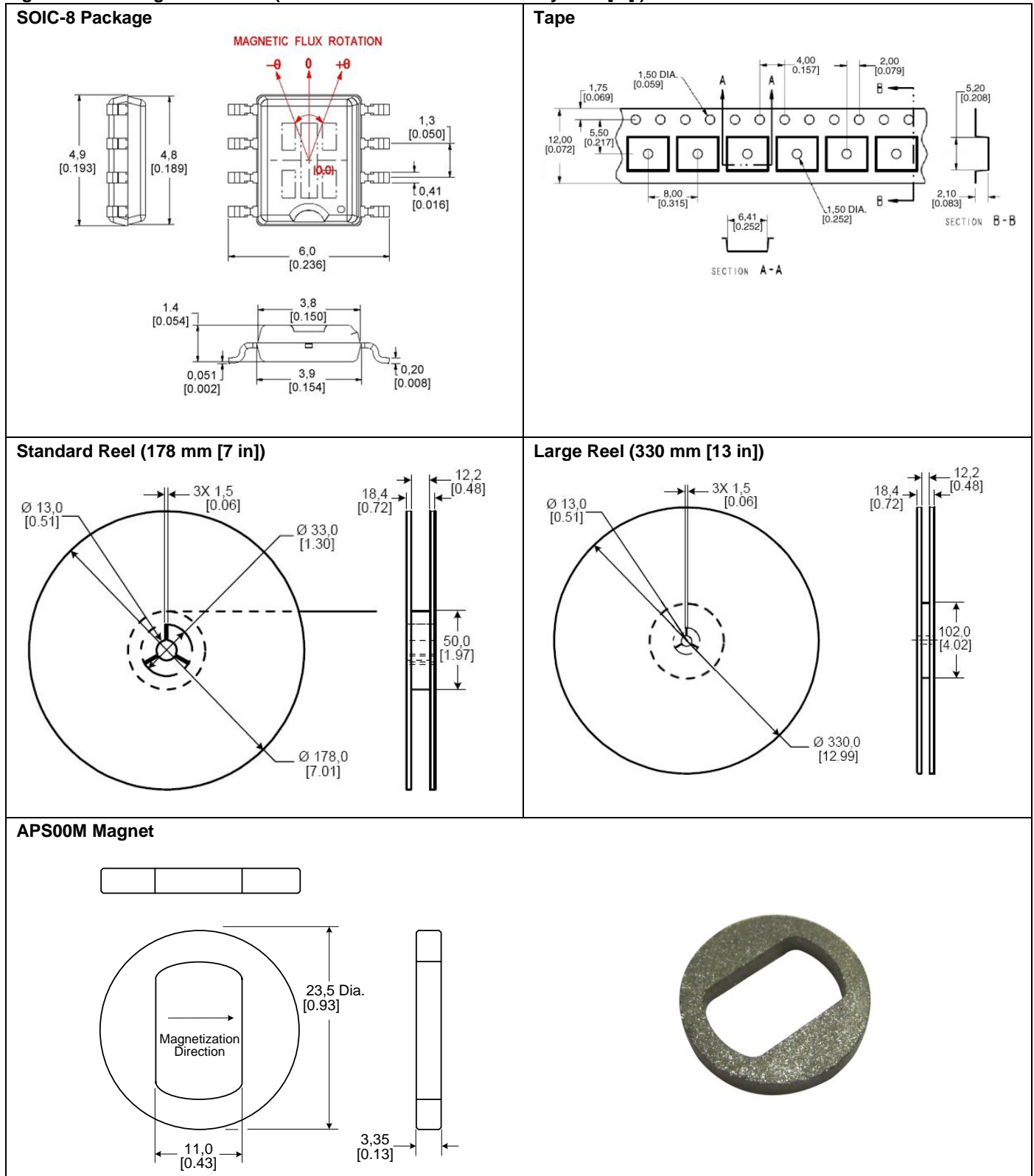

Figure 6. Typical Wiring Diagram with Honeywell APS00A Instrumentation Amplifier



High Resolution Magnetic Angular Position Sensor IC

Figure 7. Mounting Dimensions (All dimensions for reference only: mm/[in].)



Order Guide

Catalog Listing	Description
APS00B	High resolution magnetic angular position sensor IC, SOIC-8 surface-mount package, on tape and reel, 1,000 pieces on standard reel (178 mm [7 in])
APS00B-T13	High resolution magnetic angular position sensor IC, SOIC-8 surface-mount package, on tape and reel, 4,000 pieces on large reel (330 mm [13 in])
APS00A	Instrumentation amplifier for APS00B, SOIC-8 surface-mount package, on tape and reel, 1,000 pieces on standard reel (178 mm [7 in])
APS00M	Special magnet for APS00B

WARNING

PERSONAL INJURY

DO NOT USE these products as safety or emergency stop devices or in any other application where failure of the product could result in personal injury.

Failure to comply with these instructions could result in death or serious injury.

WARRANTY/REMEDY

Honeywell warrants goods of its manufacture as being free of defective materials and faulty workmanship. Honeywell's standard product warranty applies unless agreed to otherwise by Honeywell in writing; please refer to your order acknowledgement or consult your local sales office for specific warranty details. If warranted goods are returned to Honeywell during the period of coverage, Honeywell will repair or replace, at its option, without charge those items it finds defective. **The foregoing is buyer's sole remedy and is in lieu of all other warranties, expressed or implied, including those of merchantability and fitness for a particular purpose. In no event shall Honeywell be liable for consequential, special, or indirect damages.**

While we provide application assistance personally, through our literature and the Honeywell web site, it is up to the customer to determine the suitability of the product in the application.

Specifications may change without notice. The information we supply is believed to be accurate and reliable as of this printing. However, we assume no responsibility for its use.

WARNING

MISUSE OF DOCUMENTATION

- The information presented in this product sheet is for reference only. DO NOT USE this document as a product installation guide.
- Complete installation, operation, and maintenance information is provided in the instructions supplied with each product.

Failure to comply with these instructions could result in death or serious injury.

SALES AND SERVICE

Honeywell serves its customers through a worldwide network of sales offices, representatives and distributors. For application assistance, current specifications, pricing or name of the nearest Authorized Distributor, contact your local sales office or:

E-mail: info.sc@honeywell.com

Internet: www.honeywell.com/sensing

Phone and Fax:

Asia Pacific	+65 6355-2828 +65 6445-3033 Fax
Europe	+44 (0) 1698 481481 +44 (0) 1698 481676 Fax
Latin America	+1-305-805-8188 +1-305-883-8257 Fax
USA/Canada	+1-800-537-6945 +1-815-235-6847 +1-815-235-6545 Fax



Sensing and Control
Honeywell
1985 Douglas Drive North
Golden Valley, MN 55422
www.honeywell.com/sensing

005924-2-EN IL50 GLO Printed in USA
August 2011
© 2011 Honeywell International Inc. All rights reserved.

Honeywell

Looking for pricing, stock, or lifecycle information?

Click below to explore more details on WIN SOURCE:

-  [View APS00B on WIN SOURCE](#)
-  [Honeywell Information](#)

Optimize Your Supply Chain with WIN SOURCE Solutions

-  Global Sourcing Solution
-  Obsolete Management
-  Cost Control Management
-  Shortage Management
-  Alternative Solution
-  Excess Inventory Management