



**THE DATASHEET OF  
SN65HVD233SJD**



## SN65HVD233-HT 3.3-V CAN Transceiver

### 1 Features

- Bus-Pin Fault Protection Exceeds  $\pm 36$  V
- Bus-Pin ESD Protection Exceeds 16-kV Human Body Model (HBM)
- Compatible With ISO 11898
- Signaling Rates<sup>(1)</sup> up to 1 Mbps
- Extended  $-7$ -V to 12-V Common-Mode Range
- High-Input Impedance Allows for 120 Nodes
- LVTTTL I/Os Are 5-V Tolerant
- Adjustable Driver Transition Times for Improved Signal Quality
- Unpowered Node Does Not Disturb the Bus
- Low-Current Standby Mode: 200  $\mu$ A Typical
- Power-Up and Power-Down Glitch-Free Bus Inputs and Outputs
  - High-Input Impedance With Low  $V_{CC}$
  - Monolithic Output During Power Cycling
- Loopback for Diagnostic Functions Available
- DeviceNet™ Vendor ID #806

<sup>(1)</sup> The signaling rate of a line is the number of voltage transitions that are made per second expressed in the units bps (bits per second).

### 2 Applications

- Down-Hole Drilling
- High-Temperature Environments
- Industrial Automation
  - DeviceNet Data Buses
  - Smart Distributed Systems (SDS™)
- SAE J1939 Data Bus Interfaces
- NMEA 2000 Data Bus Interfaces
- ISO 11783 Data Bus Interfaces
- CAN Data Bus Interfaces
- Controlled Baseline
- One Assembly or Test Site
- One Fabrication Site
- Available in Extreme ( $-55^{\circ}\text{C}$  to  $210^{\circ}\text{C}$ ) Temperature Range <sup>(1)</sup>
- Extended Product Life Cycle
- Extended Product-Change Notification
- Product Traceability
- Texas Instruments high-temperature products use highly optimized silicon (die) solutions with design and process enhancements to maximize performance over extended temperatures.

<sup>(1)</sup> Custom temperature ranges available

### 3 Description

The SN65HVD233 is used in applications employing the controller area network (CAN) serial communication physical layer in accordance with the ISO 11898 standard, with the exception that the thermal shutdown is removed. As a CAN transceiver, the device provides transmit and receive capability between the differential CAN bus and a CAN controller, with signaling rates up to 1 Mbps.

Designed for operation in especially harsh environments, the device features cross wire, overvoltage, and loss-of-ground protection to  $\pm 36$  V, with common-mode transient protection of  $\pm 100$  V. This device operates over a  $-7$ -V to 12-V common-mode range with a maximum of 60 nodes on a bus.

If the common-mode range is restricted to the ISO 11898 standard range of  $-2$  V to 7 V, up to 120 nodes may be connected on a bus. This transceiver interfaces the single-ended CAN controller with the differential CAN bus found in industrial, building automation, and automotive applications.

#### Device Information<sup>(1)</sup>

PART NUMBER	PACKAGE	BODY SIZE (NOM)
SN65HVD233-HT	SOIC (8)	4.90 mm x 3.91 mm
	CFP-HKJ (8)	6.90 mm x 5.65 mm
	CFP-HKQ (8)	6.90 mm x 5.65 mm
	CDIP SB (8)	40.64 mm x 10.04 mm

<sup>(1)</sup> For all available packages, see the orderable addendum at the end of the datasheet.

#### Functional Block Diagram

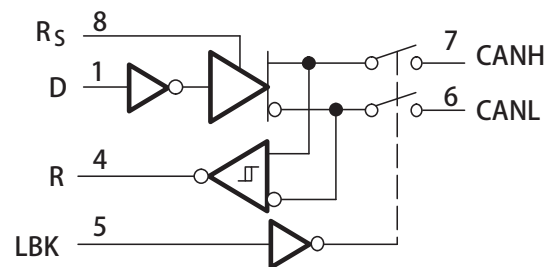

## Table of Contents

<b>1 Features</b> .....	<b>1</b>	<b>9 Detailed Description</b> .....	<b>20</b>
<b>2 Applications</b> .....	<b>1</b>	9.1 Overview .....	20
<b>3 Description</b> .....	<b>1</b>	9.2 Functional Block Diagram .....	20
<b>4 Revision History</b> .....	<b>2</b>	9.3 Feature Description .....	20
<b>5 Description (Continued)</b> .....	<b>3</b>	9.4 Device Functional Modes .....	22
<b>6 Pin Configuration and Functions</b> .....	<b>3</b>	<b>10 Application and Implementation</b> .....	<b>24</b>
<b>7 Specifications</b> .....	<b>6</b>	10.1 Application Information .....	24
7.1 Absolute Maximum Ratings .....	6	10.2 Typical Application .....	24
7.2 ESD Ratings .....	6	<b>11 Power Supply Recommendations</b> .....	<b>26</b>
7.3 Recommended Operating Conditions .....	6	<b>12 Layout</b> .....	<b>26</b>
7.4 Thermal Information .....	7	12.1 Layout Guidelines .....	26
7.5 Driver Electrical Characteristics .....	8	12.2 Layout Example .....	27
7.6 Receiver Electrical Characteristics .....	9	<b>13 Device and Documentation Support</b> .....	<b>28</b>
7.7 Driver Switching Characteristics .....	10	13.1 Trademarks .....	28
7.8 Receiver Switching Characteristics .....	11	13.2 Electrostatic Discharge Caution .....	28
7.9 Device Switching Characteristics .....	11	13.3 Glossary .....	28
7.10 Typical Characteristics .....	13	<b>14 Mechanical, Packaging, and Orderable Information</b> .....	<b>28</b>
<b>8 Parameter Measurement Information</b> .....	<b>15</b>		

## 4 Revision History

### Changes from Revision F (August 2012) to Revision G

Page

- Added *Handling Rating* table, *Feature Description* section, *Device Functional Modes*, *Application and Implementation* section, *Power Supply Recommendations* section, *Layout* section, *Device and Documentation Support* section, and *Mechanical, Packaging, and Orderable Information* section ..... **6**

## 5 Description (Continued)

$R_S$  (pin 8) provides for three modes of operation: high-speed, slope control, or low-power standby mode. The high-speed mode of operation is selected by connecting  $R_S$  directly to ground, thus allowing the driver output transistors to switch on and off as fast as possible with no limitation on the rise and fall slope. The rise and fall slope can be adjusted by connecting a resistor to ground at  $R_S$ , because the slope is proportional to the output current of the pin. Slope control is implemented with a resistor value of 10 k $\Omega$  to achieve a slew rate of  $\approx 15$  V/ $\mu$ s, and a value of 100 k $\Omega$  to achieve  $\approx 2$  V/ $\mu$ s slew rate. For more information about slope control, refer to the [Application and Implementation](#) section.

The SN65HVD233 enters a low-current standby mode, during which the driver is switched off and the receiver remains active if a high logic level is applied to  $R_S$ . The local protocol controller reverses this low-current standby mode when it needs to transmit to the bus.

A logic high on the loopback (LBK, pin 5) of the SN65HVD233 places the bus output and bus input in a high-impedance state. The remaining circuit remains active and available for the driver to receiver loopback, self-diagnostic node functions without disturbing the bus.

## 6 Pin Configuration and Functions

**D, JDJ, and HKJ Packages  
8-Pin SOIC, CDIP SB, and CFP  
Top View**

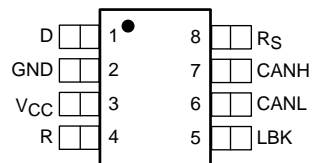

**HKQ Package  
8-Pin CFP  
Top View**

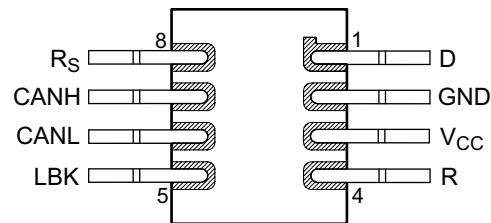

HKQ as formed or HKJ mounted dead bug.

### Pin Functions

PIN		TYPE	DESCRIPTION
NO.	NAME		
1	D	I	CAN Transmit Data input (Low for dominant and HIGH for recessive bus states)
2	GND	Power	Ground connection
3	VCC	Power	VCC
4	R	O	CAN Receive data output
5	LBK	I	LoopBack (Active high to enable controller loopback mode)
6	CFANL	I/O	Low level CAN bus line
7	CANH	I/O	High level CAN bus line
8	Rs	I	High Speed, Slope control, and standby enable mode input.

**Bare Die Information**

DIE THICKNESS	BACKSIDE FINISH	BACKSIDE POTENTIAL	BOND PAD METALLIZATION COMPOSITION
15 mils.	Silicon with backgrind	GND	Al-Si-Cu (0.5%)

Origin

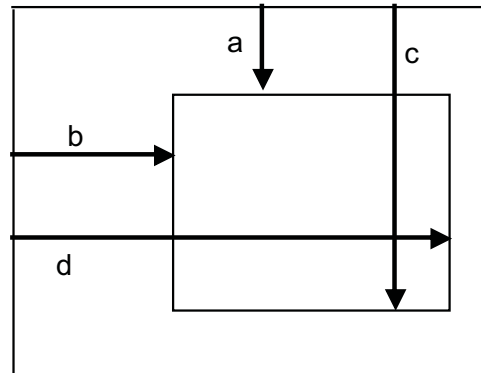
**Bond Pad Coordinates In Microns - Rev A**

DESCRIPTION	PAD NUMBER	A	B	C	D
D	1	86.40	157.85	203.40	274.85
GND	2	1035.05	69.75	1150.05	184.75
GND	3	1168.15	69.75	1283.15	184.75
VCC	4	1572.05	51.85	1687.05	166.85
VCC	5	1711.95	51.85	1826.95	166.85
R	6	2758.85	237.65	2873.85	352.65
LBK	7	2774.25	1429.985	2889.25	1544.95
CANL	8	1549.90	1544.95	1664.90	1659.95
CANH	9	1351.45	1544.95	1466.45	1659.95
RS	10	83.50	1429.95	198.50	1544.95

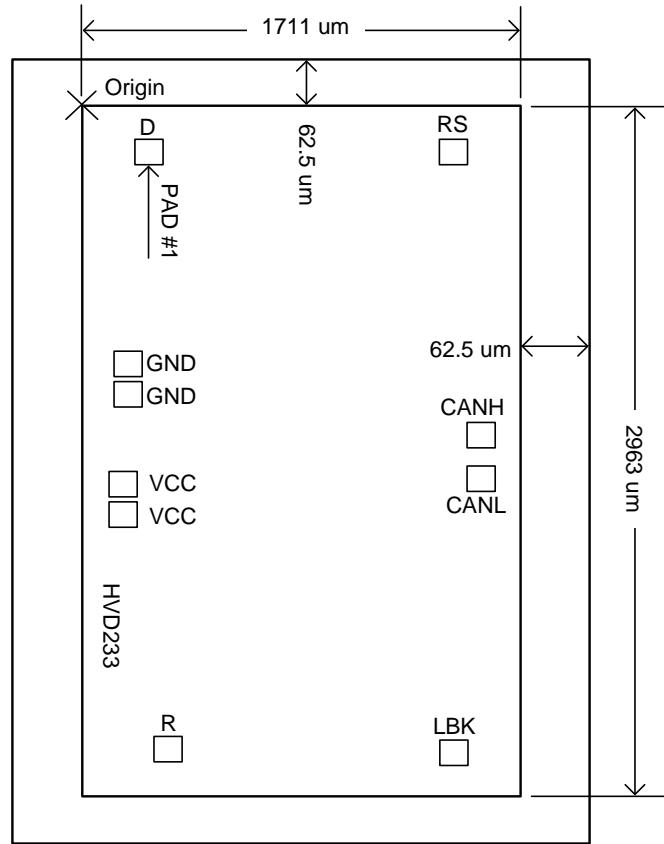

## 7 Specifications

### 7.1 Absolute Maximum Ratings

 over operating free-air temperature range (unless otherwise noted) <sup>(1)(2)</sup>

		MIN	MAX	UNIT
V <sub>CC</sub>	Supply voltage range	-0.3	7	V
	Voltage range at any bus terminal (CANH or CANL)	-36	36	V
	Voltage input range, transient pulse (CANH and CANL) through 100 Ω (see Figure 19)	-100	100	V
V <sub>I</sub>	Input voltage range (D, R, R <sub>S</sub> , LBK)	-0.5	7	V
I <sub>O</sub>	Receiver output current	-10	10	mA
T <sub>stg</sub>	Storage temperature	-65	150	°C

- (1) Stresses beyond those listed under *Absolute Maximum Ratings* may cause permanent damage to the device. These are stress ratings only, which do not imply functional operation of the device at these or any other conditions beyond those indicated under *Recommended Operating Conditions*. Exposure to absolute-maximum-rated conditions for extended periods may affect device reliability.
- (2) All voltage values, except differential I/O bus voltages, are with respect to network ground terminal.

### 7.2 ESD Ratings

			VALUE	UNIT	
V <sub>(ESD)</sub>	Electrostatic discharge	Human body model (HBM), per ANSI/ESDA/JEDEC JS-001, all pins <sup>(1)</sup>	CANH, CANL, and GND	±16000	V
			All pins	±3000	
		Charged device model (CDM), per JEDEC specification JESD22-C101, all pins <sup>(2)</sup>		±1000	

- (1) JEDEC document JEP155 states that 500-V HBM allows safe manufacturing with a standard ESD control process.
- (2) JEDEC document JEP157 states that 250-V CDM allows safe manufacturing with a standard ESD control process.

### 7.3 Recommended Operating Conditions

 T<sub>A</sub> = -55°C to 210°C

		MIN	MAX	UNIT
V <sub>CC</sub>	Supply voltage	3	3.6	V
	Voltage at any bus terminal (separately or common mode)	-7	12	V
V <sub>IH</sub>	High-level input voltage	D, LBK	5.5	V
V <sub>IL</sub>	Low-level input voltage	D, LBK	0.8	V
V <sub>ID</sub>	Differential input voltage	-6	6	V
	Resistance from R <sub>S</sub> to ground	0	100	kΩ
V <sub>I(RS)</sub>	Input voltage at R <sub>S</sub> for standby	0.75 V <sub>CC</sub>	5.5	V
I <sub>OH</sub>	High-level output current	Driver	-50	mA
		Receiver	-10	
I <sub>OL</sub>	Low-level output current	Driver	50	mA
		Receiver	10	
T <sub>J</sub>	Operating junction temperature		212	°C
T <sub>A</sub>	Operating free-air temperature <sup>(1)</sup>	-55	210	°C

- (1) Maximum free-air temperature operation is allowed as long as the device maximum junction temperature is not exceeded.

## 7.4 Thermal Information

THERMAL METRIC <sup>(1)</sup>		SN65HVD233-HT			UNIT
		D	HJK/HKQ	JDJ	
		8 PINS	8 PINS	8 PINS	
$R_{\theta JA}$	Junction-to-ambient thermal resistance	106.4	146.1	72.7	°C/W
$R_{\theta JC(top)}$	Junction-to-case (top) thermal resistance	55.8	23.7	3.1	
$R_{\theta JB}$	Junction-to-board thermal resistance	46.5	152.0	38.3	
$\Psi_{JT}$	Junction-to-top characterization parameter	10.7	20.7	6.0	
$\Psi_{JB}$	Junction-to-board characterization parameter	45.9	93.1	26.9	

(1) For more information about traditional and new thermal metrics, see the *IC Package Thermal Metrics* application report, [SPRA953](#).

## 7.5 Driver Electrical Characteristics

over operating free-air temperature range (unless otherwise noted)

PARAMETER		TEST CONDITIONS	T <sub>A</sub> = -55°C to 125°C			T <sub>A</sub> = 175°C <sup>(1)</sup>			T <sub>A</sub> = 210°C <sup>(2)</sup>			UNIT			
			MIN	TYP	MAX	MIN	TYP	MAX	MIN	TYP	MAX				
V <sub>O(D)</sub>	Bus output voltage (dominant)	CANH	D = 0 V, R <sub>S</sub> = 0 V, See Figure 13 and Figure 14			2.45		V <sub>CC</sub>	2.45		V <sub>CC</sub>	2.45		V <sub>CC</sub>	V
		CANL				0.5		1.25	0.5		1.25	0.5		1.25	
V <sub>O</sub>	Bus output voltage (recessive)	CANH	D = 3 V, R <sub>S</sub> = 0 V, See Figure 13 and Figure 14			2.3			2.3			2.3			V
		CANL				2.3			2.3			2.3			
V <sub>OD(D)</sub>	Differential output voltage (Dominant)			D = 0 V, R <sub>S</sub> = 0 V, See Figure 13 and Figure 14	1.5	2	3	1.4	1.75	3	1.4	1.75	3	V	
				D = 0 V, R <sub>S</sub> = 0 V, See Figure 14 and Figure 15	1.1	2	3	1.1	1.47	3	1.1	1.47	3		
V <sub>OD</sub>	Differential output voltage (Recessive)			D = 3 V, R <sub>S</sub> = 0 V, See Figure 13 and Figure 14	-120		12	-120		12	-120		12	mV	
				D = 3 V, R <sub>S</sub> = 0 V, No load	-0.5		0.05	-0.5		0.8	-0.5		1.2	V	
V <sub>OC(pp)</sub>	Peak-to-peak common-mode output voltage			See Figure 21	1			1			1			V	
I <sub>IH</sub>	High-level input current	D, LBK	D = 2 V		-30		30	-30		30	-30		30	μA	
I <sub>IL</sub>	Low-level input current	D, LBK	D = 0.8 V		-30		30	-30		30	-30		30	μA	
I <sub>OS</sub>	Short-circuit output current			V <sub>CANH</sub> = -7 V, CANL open, See Figure 24	-250			-250			-250			mA	
				V <sub>CANH</sub> = 12 V, CANL open, See Figure 24				1			1				
				V <sub>CANL</sub> = -7 V, CANH open, See Figure 24	-1			-1			-1				
				V <sub>CANL</sub> = 12 V, CANH open, See Figure 24				250			250				
C <sub>O</sub>	Output capacitance			See receiver input capacitance											
I <sub>IRs(s)</sub>	R <sub>S</sub> input current for standby			R <sub>S</sub> = 0.75 V <sub>CC</sub>	-10			-10			-10			μA	
I <sub>CC</sub>	Supply current	Standby	R <sub>S</sub> = V <sub>CC</sub> , D = V <sub>CC</sub> , LBK = 0 V		200		600	400		600	400		600	μA	
		Dominant	D = 0 V, No load, LBK = 0 V, R <sub>S</sub> = 0 V		6			6			6			mA	
		Recessive	D = t V <sub>CC</sub> , No load, LBK = 0 V, R <sub>S</sub> = 0 V		6			6			6				

- (1) Minimum and maximum parameters are characterized for operation at T<sub>A</sub> = 175°C and production tested at T<sub>A</sub> = 125°C.  
 (2) Minimum and maximum parameters are characterized for operation at T<sub>A</sub> = 210°C but may not be production tested at that temperature. Production test limits with statistical guardbands are used to ensure high temperature performance.

## 7.6 Receiver Electrical Characteristics

over operating free-air temperature range (unless otherwise noted)

PARAMETER	TEST CONDITIONS	$T_A = -55^\circ\text{C to } 125^\circ\text{C}$			$T_A = 175^\circ\text{C}^{(1)}$			$T_A = 210^\circ\text{C}^{(2)}$			UNIT
		MIN	TYP	MAX	MIN	TYP	MAX	MIN	TYP	MAX	
$V_{IT+}$	Positive-going input threshold voltage	620 900			600 900			600 900			mV
$V_{IT-}$	Negative-going input threshold voltage	500 715			500 725			500 725			mV
$V_{hys}$	Hysteresis voltage ( $V_{IT+} - V_{IT-}$ )	100			140			140			mV
$V_{OH}$	High-level output voltage	$I_O = -4\text{ mA}$ , See Figure 18			2.4			2.4			V
$V_{OL}$	Low-level output voltage	$I_O = 4\text{ mA}$ , See Figure 18			0.4			0.4			V
$I_I$	Bus input current	CANH or CANL = 12 V	140 500		140 500		140 500		$\mu\text{A}$		
		CANH or CANL = 12 V, $V_{CC} = 0\text{ V}$	200 600		200 700		200 800				
		CANH or CANL = -7 V	-610 -150		-610 -150		-610 -150				
		CANH or CANL = -7 V, $V_{CC} = 0\text{ V}$	-450 -130		-450 -130		-450 -130				
$C_I$	Input capacitance (CANH or CANL)	Pin to ground, $V_I = 0.4 \sin(4E6\pi t) + 0.5\text{ V}$ , $D = 3\text{ V}$ , $\text{LBK} = 0\text{ V}$		45		55		55		pF	
		Pin to pin, $V_I = 0.4 \sin(4E6\pi t) + 0.5\text{ V}$ , $D = 3\text{ V}$ , $\text{LBK} = 0\text{ V}$		15		15		15			
$R_{ID}$	Differential input resistance	$D = 3\text{ V}$ , $\text{LBK} = 0\text{ V}$		40 110		40 110		40 110		k $\Omega$	
$R_{IN}$	Input resistance (CANH or CANL)	$D = 3\text{ V}$ , $\text{LBK} = 0\text{ V}$		20 51		19 51		18 51		k $\Omega$	
$I_{CC}$	Supply current	Standby	$R_S = V_{CC}$ , $D = V_{CC}$ , $\text{LBK} = 0\text{ V}$		200 600		400 600		400 600		$\mu\text{A}$
		Dominant	$D = 0\text{ V}$ , No load, $R_S = 0\text{ V}$ , $\text{LBK} = 0\text{ V}$		6		6		6		mA
		Recessive	$D = V_{CC}$ , No load, $R_S = 0\text{ V}$ , $\text{LBK} = 0\text{ V}$		6		6		6		

- (1) Minimum and maximum parameters are characterized for operation at  $T_A = 210^\circ\text{C}$  and are not characterized or production tested at  $T_A = 175^\circ\text{C}$ .
- (2) Minimum and maximum parameters are characterized for operation at  $T_A = 210^\circ\text{C}$  but may not be production tested at that temperature. Production test limits with statistical guardbands are used to ensure high temperature performance.

## 7.7 Driver Switching Characteristics

over operating free-air temperature range (unless otherwise noted)

PARAMETER	TEST CONDITIONS	$T_A = -55^\circ\text{C to } 125^\circ\text{C}$			$T_A = 175^\circ\text{C}^{(1)}$			$T_A = 210^\circ\text{C}^{(2)}$			UNIT
		MIN	TYP	MAX	MIN	TYP	MAX	MIN	TYP	MAX	
$t_{PLH}$	Propagation delay time, low-to-high-level output $R_S = 0\text{ V}$ , See <a href="#">Figure 16</a>		35	85		50			50		ns
	$R_S$ with 10 k $\Omega$ to ground, See <a href="#">Figure 16</a>		70	125		75			75		
	$R_S$ with 100 k $\Omega$ to ground, See <a href="#">Figure 16</a>		500	870		500			500		
$t_{PHL}$	Propagation delay time, high-to-low-level output $R_S = 0\text{ V}$ , See <a href="#">Figure 16</a>		70	120		70			70		ns
	$R_S$ with 10 k $\Omega$ to ground, See <a href="#">Figure 16</a>		130	180		130			130		
	$R_S$ with 100 k $\Omega$ to ground, See <a href="#">Figure 16</a>		870	1200		870			870		
$t_{sk(p)}$	Pulse skew ( $ t_{PHL} - t_{PLH} $ ) $R_S = 0\text{ V}$ , See <a href="#">Figure 16</a>		35			9			9		ns
	$R_S$ with 10 k $\Omega$ to ground, See <a href="#">Figure 16</a>		60			35			35		
	$R_S$ with 100 k $\Omega$ to ground, See <a href="#">Figure 16</a>		370			475			475		
$t_r$	Differential output signal rise time	$R_S = 0\text{ V}$ , See <a href="#">Figure 16</a>	20	70	20	75	20	75	ns		
$t_f$	Differential output signal fall time		18	70	20	75	20	75			
$t_r$	Differential output signal rise time	$R_S$ with 10 k $\Omega$ to ground, See <a href="#">Figure 16</a>	30	135	30	140	30	140	ns		
$t_f$	Differential output signal fall time		30	135	30	140	30	140			
$t_r$	Differential output signal rise time	$R_S$ with 100 k $\Omega$ to ground, See <a href="#">Figure 16</a>	250	1400	250	1400	250	1400	ns		
$t_f$	Differential output signal fall time		350	1400	350	1400	350	1400			
$t_{en(s)}$	Enable time from standby to dominant	See <a href="#">Figure 20</a>	0.6	1.5	0.6	1.5	0.6	1.5	$\mu\text{s}$		

- (1) Minimum and maximum parameters are characterized for operation at  $T_A = 210^\circ\text{C}$  but not production tested at  $T_A = 175^\circ\text{C}$  or  $210^\circ\text{C}$ .  
 (2) Minimum and maximum parameters are characterized for operation at  $T_A = 210^\circ\text{C}$  but may not be production tested at that temperature. Production test limits with statistical guardbands are used to ensure high temperature performance.

## 7.8 Receiver Switching Characteristics

over operating free-air temperature range (unless otherwise noted)

PARAMETER	TEST CONDITIONS	$T_A = -55^{\circ}\text{C to } 125^{\circ}\text{C}$			$T_A = 175^{\circ}\text{C}^{(1)}$			$T_A = 210^{\circ}\text{C}^{(2)}$			UNIT
		MIN	TYP	MAX	MIN	TYP	MAX	MIN	TYP	MAX	
$t_{PLH}$	Propagation delay time, low-to-high-level output	See <a href="#">Figure 18</a>	35	60	50	60	50	60	ns		
$t_{PHL}$	Propagation delay time, high-to-low-level output		35	60	45	60	45	60	ns		
$t_{sk(p)}$	Pulse skew ( $t_{PHL} - t_{PLH}$ )		7		5		5		ns		
$t_r$	Output signal rise time		2	6.5	6.5	8	6.5	8	ns		
$t_f$	Output signal fall time		2	6.5	6.5	9	6.5	9	ns		

- (1) Minimum and maximum parameters are characterized for operation at  $T_A = 210^{\circ}\text{C}$  but not production tested at  $T_A = 175^{\circ}\text{C}$  or  $210^{\circ}\text{C}$ .  
(2) Minimum and maximum parameters are characterized for operation at  $T_A = 210^{\circ}\text{C}$  but may not be production tested at that temperature. Production test limits with statistical guardbands are used to ensure high temperature performance.

## 7.9 Device Switching Characteristics

over operating free-air temperature range (unless otherwise noted)

PARAMETER	TEST CONDITIONS	$T_A = -55^{\circ}\text{C to } 125^{\circ}\text{C}$			$T_A = 175^{\circ}\text{C}^{(1)}$			$T_A = 210^{\circ}\text{C}^{(2)}$			UNIT
		MIN	TYP	MAX	MIN	TYP	MAX	MIN	TYP	MAX	
$t_{(LBK)}$	Loopback delay, driver input to receiver output	See <a href="#">Figure 23</a>	7.5	15	12	15	12	15	ns		
$t_{(loop1)}$	Total loop delay, driver input to receiver output, recessive to dominant		$R_S = 0\text{ V}$ , See <a href="#">Figure 22</a>	70	135	90	135	90	135	ns	
			$R_S$ with 10 k $\Omega$ to ground, See <a href="#">Figure 22</a>	105	190	115	190	115	190		
		$R_S$ with 100 k $\Omega$ to ground, See <a href="#">Figure 22</a>	535	1000	430	1000	430	1000			
$t_{(loop2)}$	Total loop delay, driver input to receiver output, dominant to recessive	$R_S = 0\text{ V}$ , See <a href="#">Figure 22</a>	70	135	98	135	98	135	ns		
		$R_S$ with 10 k $\Omega$ to ground, See <a href="#">Figure 22</a>	105	190	150	190	150	190			
		$R_S$ with 100 k $\Omega$ to ground, See <a href="#">Figure 22</a>	535	1100	880	1200	880	1200			

- (1) Minimum and maximum parameters are characterized for operation at  $T_A = 210^{\circ}\text{C}$  but not production tested at  $T_A = 175^{\circ}\text{C}$  or  $210^{\circ}\text{C}$ .  
(2) Minimum and maximum parameters are characterized for operation at  $T_A = 210^{\circ}\text{C}$  but may not be production tested at that temperature. Production test limits with statistical guardbands are used to ensure high temperature performance.

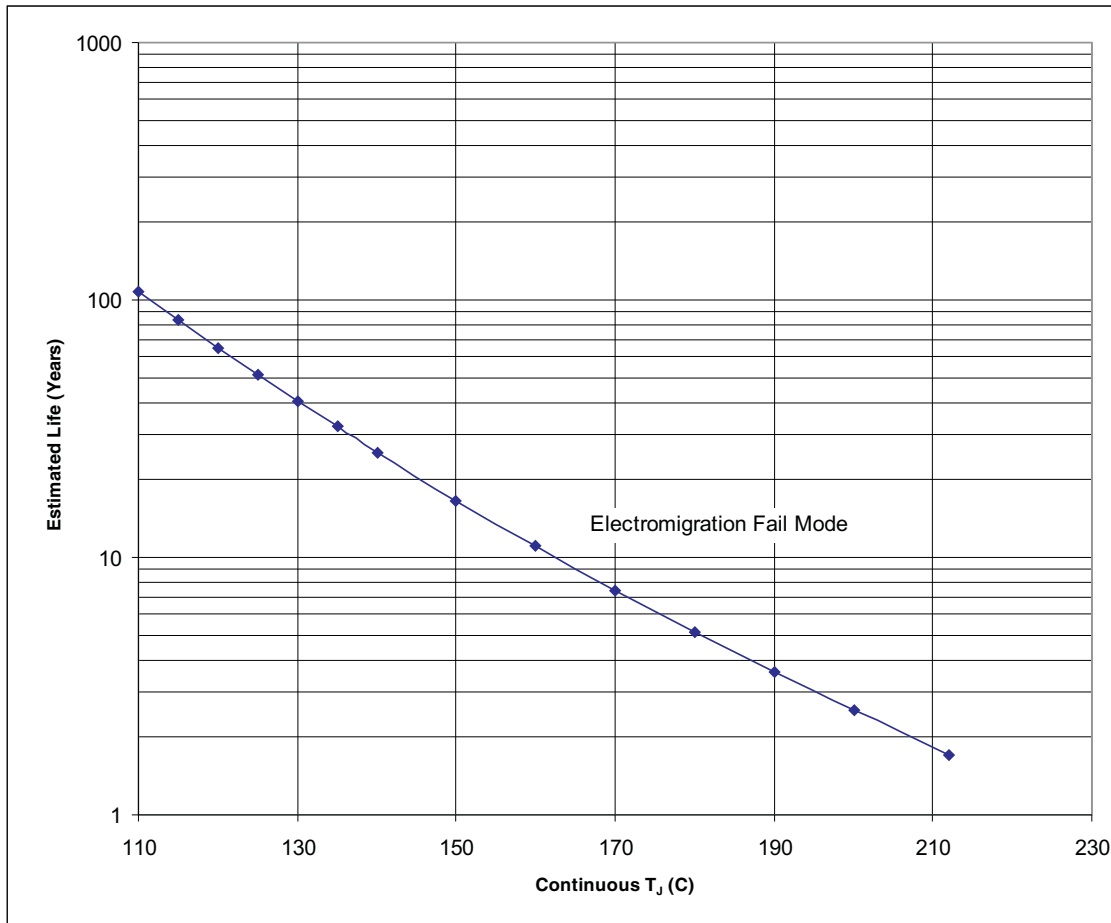

- A. See the [Specifications](#) for absolute maximum and minimum recommended operating conditions.
- B. Silicon operating life design goal is 10 years at 105°C junction temperature (does not include package interconnect life).

**Figure 1. Operating Life Derating Chart**  
**SN65HVD233HD, SN65HVD233SJD, SN65HVD233SKGDA, SN65HVD233SHKJ, SN65HVD233SHKQ**

### 7.10 Typical Characteristics

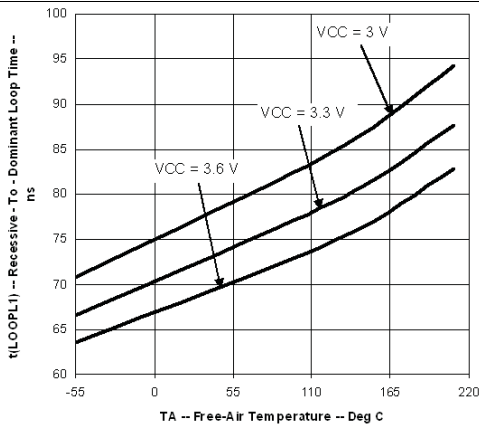

Figure 2. Recessive-to-Dominant Loop Time vs Free-Air Temperature

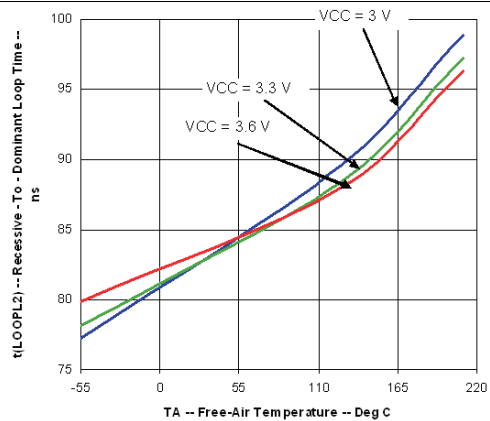

Figure 3. Dominant-to-Recessive Loop Time vs Free-Air Temperature

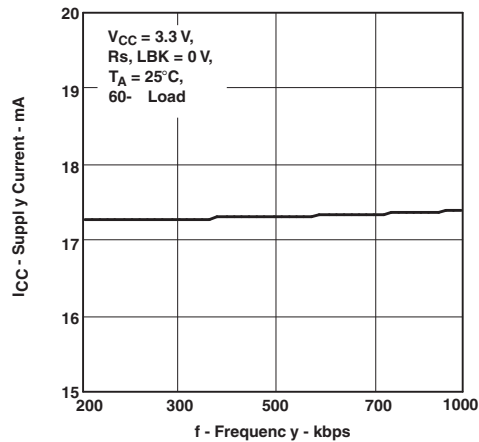

Figure 4. Supply Current vs Frequency

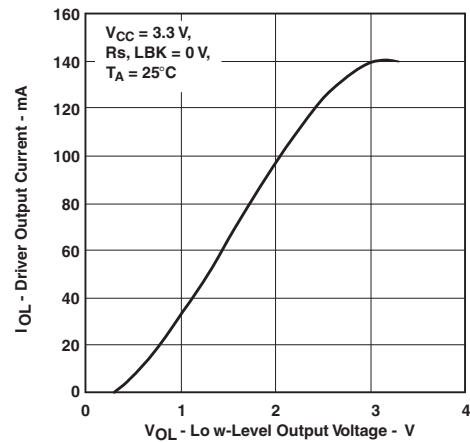

Figure 5. Driver Low-Level Output Current vs Low-Level Output Voltage

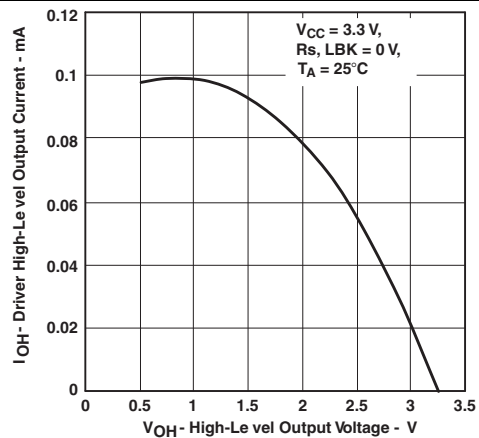

Figure 6. Driver High-Level Output Current vs High-Level Output Voltage

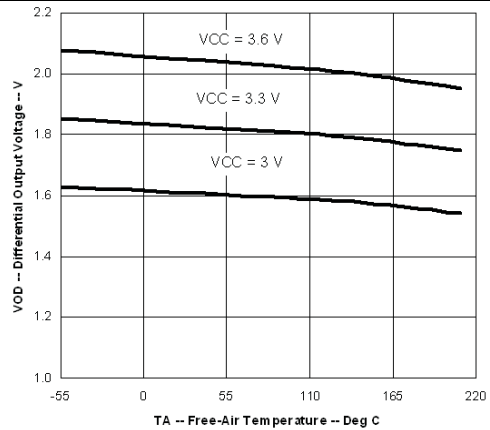

Figure 7. Differential Output Voltage vs Free-Air Temperature

Typical Characteristics (continued)

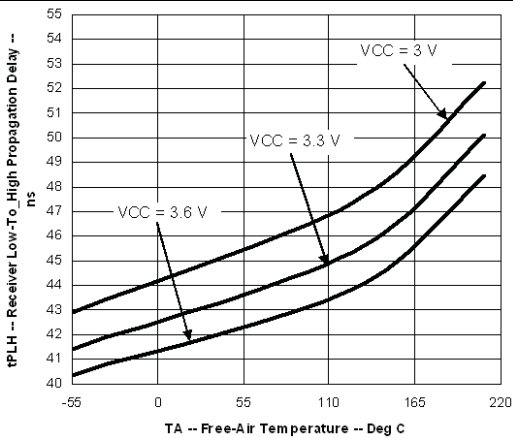

Figure 8. Receiver Low-to-High Propagation Delay vs Free-Air Temperature

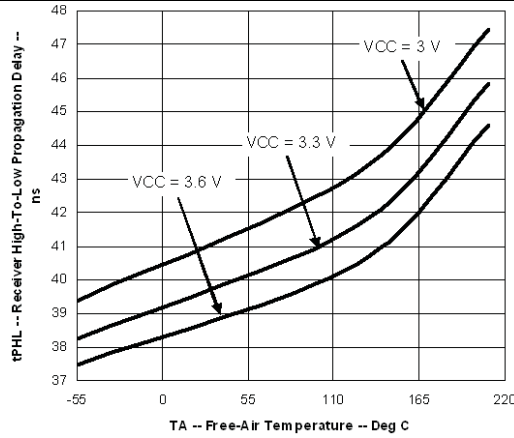

Figure 9. Receiver High-to-Low Propagation Delay vs Free-Air Temperature

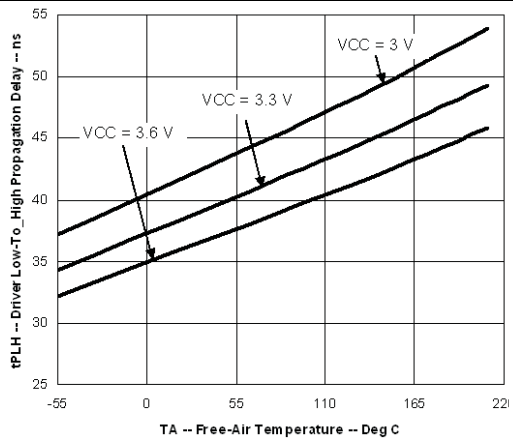

Figure 10. Driver Low-to-High Propagation Delay vs Free-Air Temperature

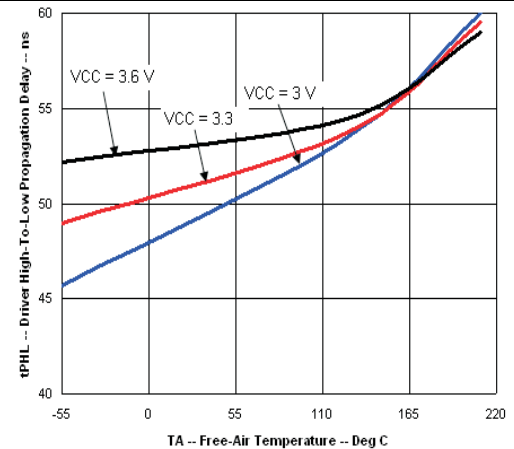

Figure 11. Driver High-to-Low Propagation Delay vs Free-Air Temperature

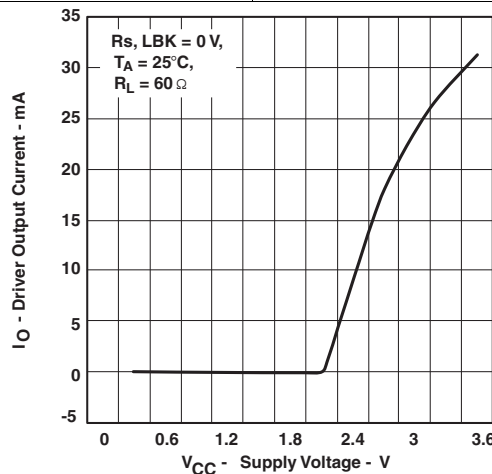

Figure 12. Driver Output Current vs Supply Voltage

## 8 Parameter Measurement Information

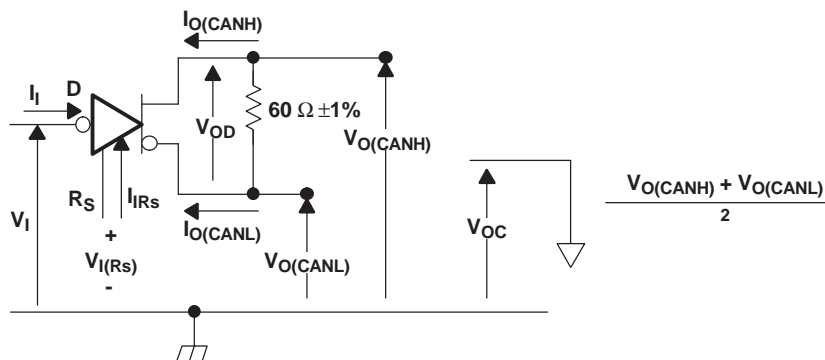

Figure 13. Driver Voltage, Current, and Test Definition

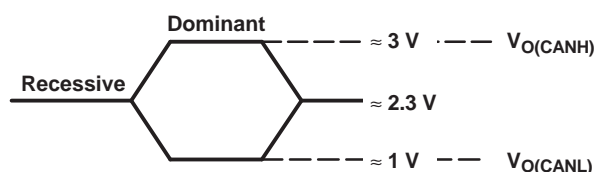

Figure 14. Bus Logic State Voltage Definitions

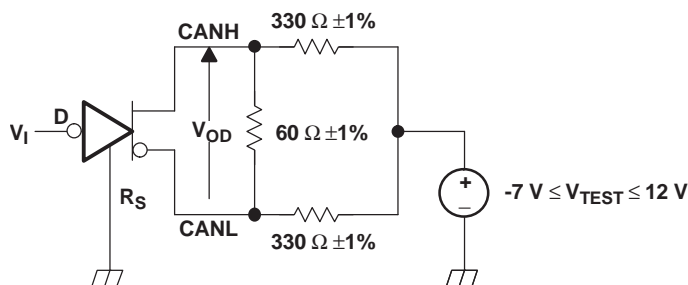
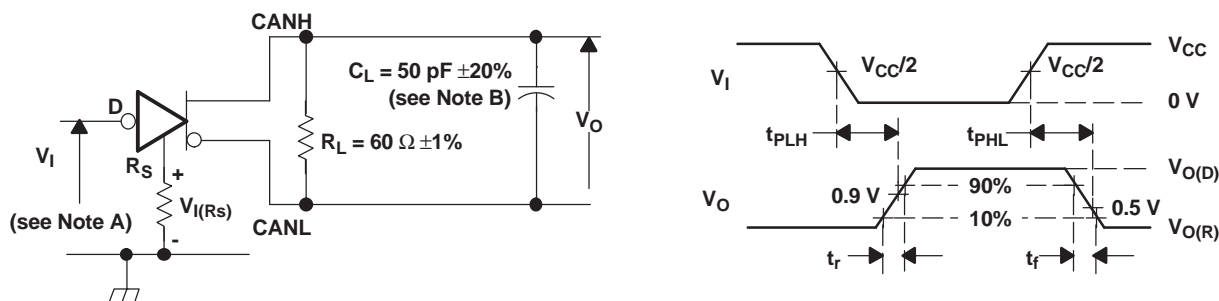

Figure 15. Driver  $V_{OD}$



- A. The input pulse is supplied by a generator having the following characteristics: Pulse repetition rate (PRR)  $\leq$  125 kHz, 50% duty cycle,  $t_r \leq 6$  ns,  $t_f \leq 6$  ns,  $Z_O = 50 \Omega$ .
- B.  $C_L$  includes fixture and instrumentation capacitance.

Figure 16. Driver Test Circuit and Voltage Waveforms

Parameter Measurement Information (continued)

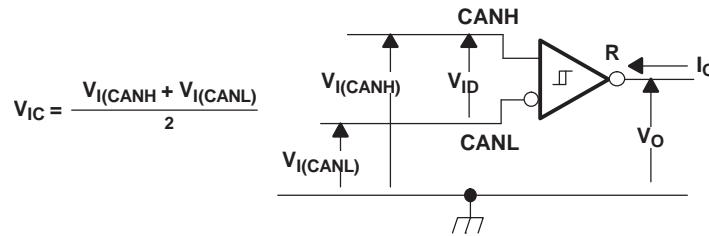
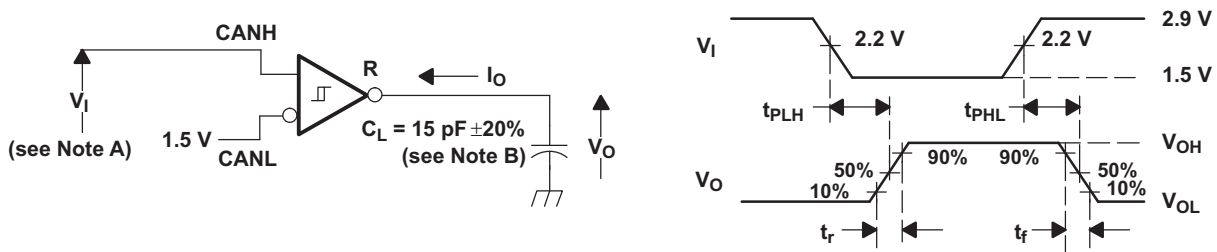

Figure 17. Receiver Voltage and Current Definitions



- A. The input pulse is supplied by a generator having the following characteristics: Pulse repetition rate (PRR) ≤ 125 kHz, 50% duty cycle,  $t_r \leq 6$  ns,  $t_f \leq 6$  ns,  $Z_0 = 50 \Omega$ .
- B.  $C_L$  includes fixture and instrumentation capacitance.

Figure 18. Receiver Test Circuit and Voltage Waveforms

Table 1. Differential Input Voltage Threshold Test

INPUT		OUTPUT	MEASURED	
$V_{CANH}$	$V_{CANL}$	R	$ V_{ID} $	
-6.1 V	-7 V	L	V <sub>OL</sub>	900 mV
12 V	11.1 V	L		900 mV
-1 V	-7 V	L		6 V
12 V	6 V	L		6 V
-6.5 V	-7 V	H	V <sub>OH</sub>	500 mV
12 V	11.5 V	H		500 mV
-7 V	-1 V	H		6 V
6 V	12 V	H		6 V
Open	Open	H		X

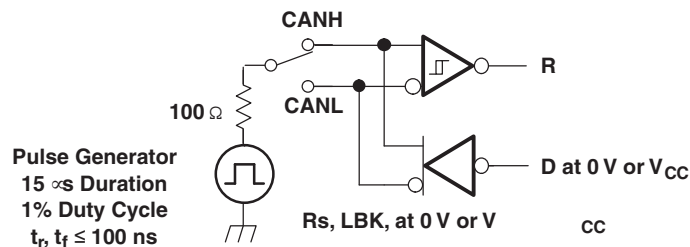

NOTE: This test is conducted to test survivability only. Data stability at the R output is not specified.

Figure 19. Test Circuit, Transient Overvoltage Test

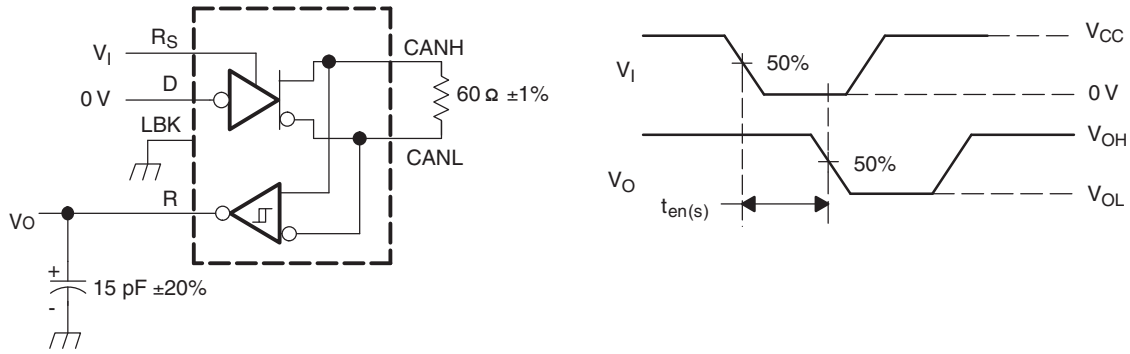

NOTE: All  $V_I$  input pulses are supplied by a generator having the following characteristics:  
 $t_r$  or  $t_f \leq 6$  ns, pulse repetition rate (PRR) = 125 kHz, 50% duty cycle.

Figure 20.  $T_{en(s)}$  Test Circuit and Voltage Waveforms

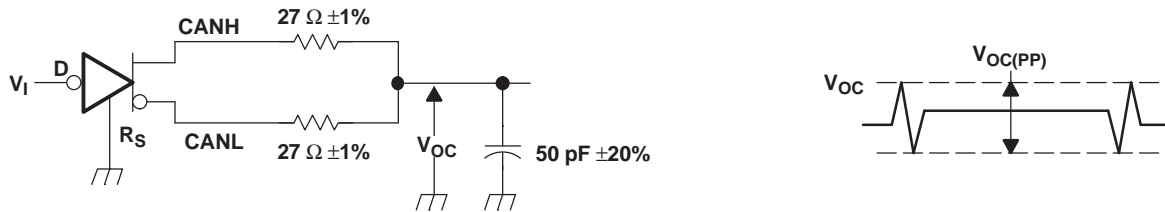

NOTE: All  $V_I$  input pulses are supplied by a generator having the following characteristics:  
 $t_r$  or  $t_f \leq 6$  ns, pulse repetition rate (PRR) = 125 kHz, 50% duty cycle.

Figure 21.  $V_{OC(pp)}$  Test Circuit and Voltage Waveforms

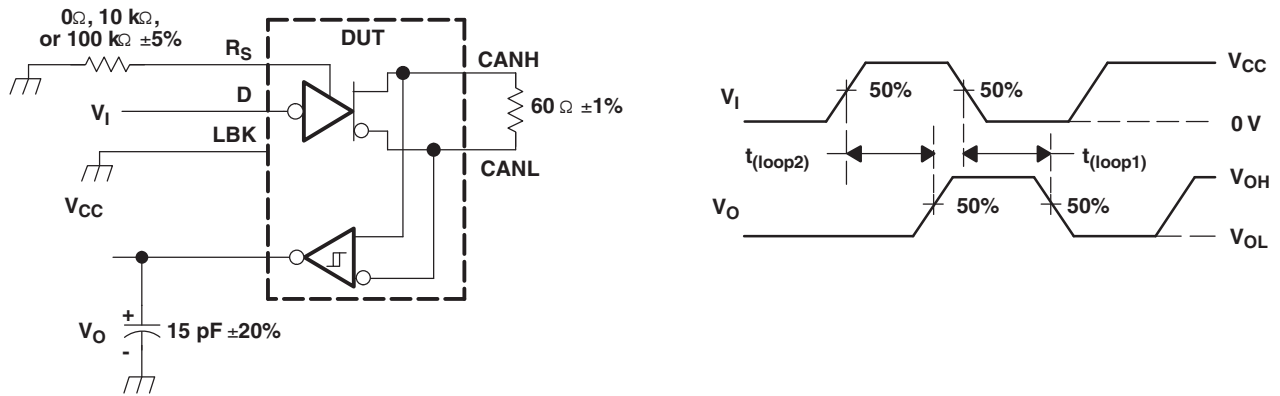

NOTE: All  $V_I$  input pulses are supplied by a generator having the following characteristics:  
 $t_r$  or  $t_f \leq 6$  ns, pulse repetition rate (PRR) = 125 kHz, 50% duty cycle.

Figure 22.  $T_{(loop)}$  Test Circuit and Voltage Waveforms

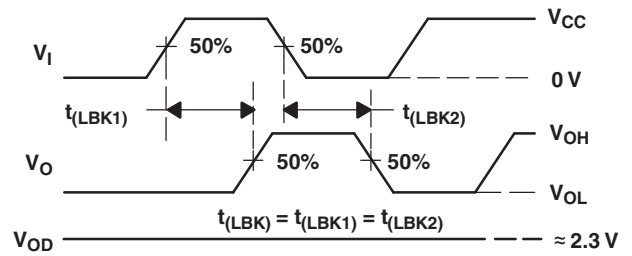
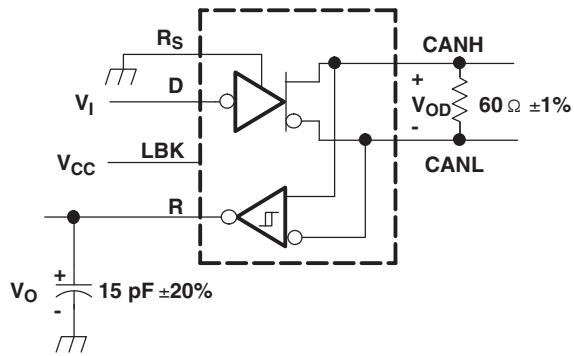

NOTE: All  $V_I$  input pulses are supplied by a generator having the following characteristics:  
 $t_r$  or  $t_f \leq 6$  ns, pulse repetition rate (PRR) = 125 kHz, 50% duty cycle.

Figure 23.  $T_{(LBK)}$  Test Circuit and Voltage Waveforms

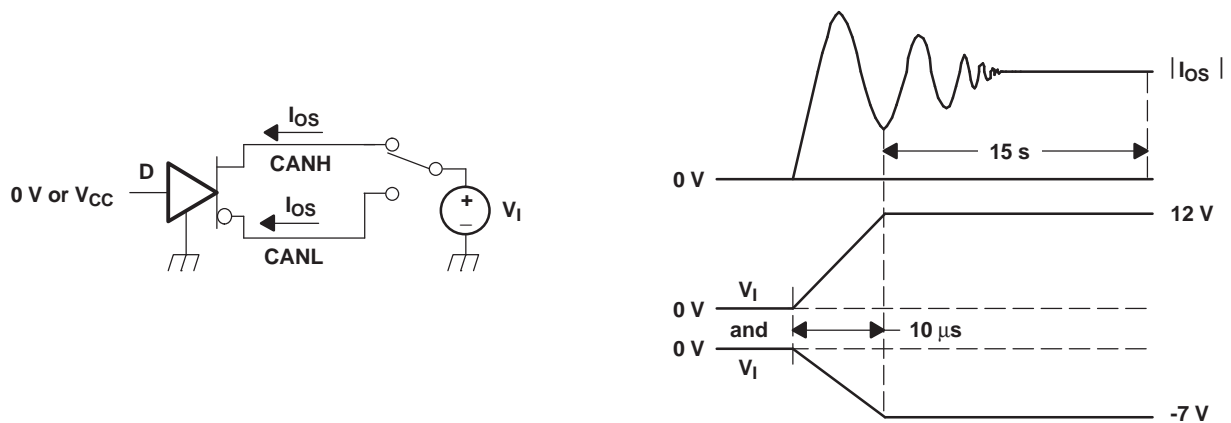
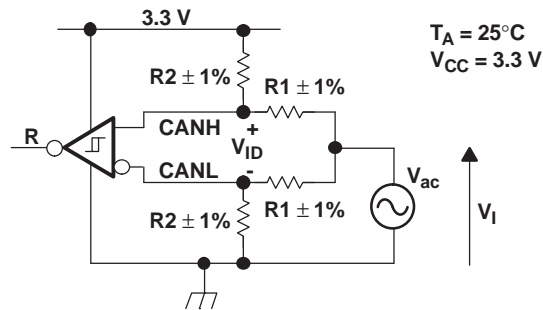

Figure 24.  $I_{OS}$  Test Circuit and Waveforms



The R Output State Does Not Change During Application of the Input Waveform.

$V_{ID}$	R1	R2
500 mV	50 $\Omega$	280 $\Omega$
900 mV	50 $\Omega$	130 $\Omega$



NOTE: All input pulses are supplied by a generator with  $f \leq 1.5$  MHz.

**Figure 25. Common-Mode Voltage Rejection**

## 9 Detailed Description

### 9.1 Overview

Controller Area Network (CAN) is a robust multi master-master, differential signaling, serial communications bus specified by the ISO 11898 family of standards. TI's SSN65HVD23x family of transceivers solve specialized networking requirements for various applications.

**Table 2. Available Options**

ORDERABLE PART NUMBER	LOW-POWER MODE	SLOPE CONTROL	DIAGNOSTIC LOOPBACK	AUTOBAUD LOOPBACK
SN65HVD233HD	200- $\mu$ A standby mode	Adjustable	Yes	No
SN65HVD233SJD				
SN65HVD233SKGDA				
SN65HVD233SHKJ				
SN65HVD233SHKQ				

### 9.2 Functional Block Diagram

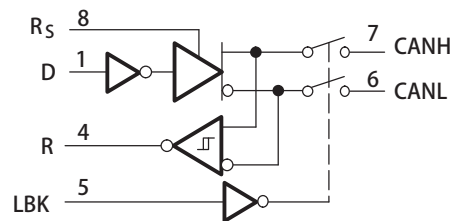

### 9.3 Feature Description

#### 9.3.1 ISO 11898 Compliance of SN65HVD23x Family of 3.3-V CAN Transceivers

Many users value the low power consumption of operating CAN transceivers from a 3.3-V supply. However, some are concerned about the interoperability with 5-V supplied transceivers on the same bus. This section analyzes this situation to address those concerns.

##### 9.3.1.1 Differential Signal

CAN is a differential bus where complementary signals are sent over two wires, and the voltage difference between the two wires defines the logical state of the bus. The differential CAN receiver monitors this voltage difference and outputs the bus state with a single-ended output signal.

## Feature Description (continued)

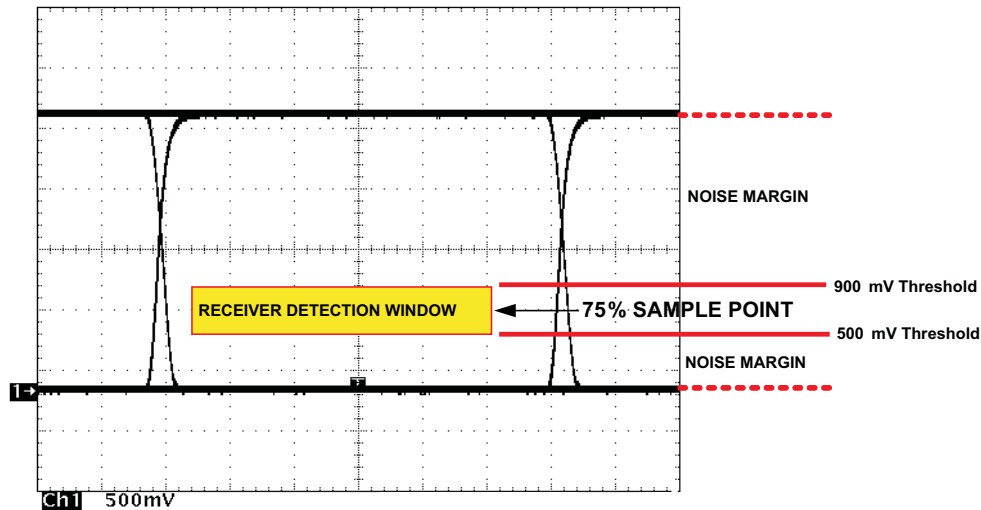

**Figure 26. Typical SN65HVD23x Differential Output Voltage Waveform**

The CAN driver creates the difference voltage between CANH and CANL in the dominant state. The dominant differential output of the SN65HVD23x is greater than 1.5 V and less than 3 V across a 60-Ω load. The minimum required by ISO 11898 is 1.5 V and the maximum is 3 V. These are the same limiting values for 5-V supplied CAN transceivers. The bus termination resistors drive the recessive bus state and not the CAN driver.

A CAN receiver is required to output a recessive state with less than 500 mV and a dominant state with more than 900-mV difference voltage on its bus inputs. The CAN receiver must do this with common-mode input voltages from -2 V to 7 V. The SN65HVD23x family receivers meet these same input specifications as 5-V supplied receivers.

### 9.3.1.1.1 Common-Mode Signal

A common-mode signal is an average voltage of the two signal wires that the differential receiver rejects. The common-mode signal comes from the CAN driver, ground noise, and coupled bus noise. Obviously, the supply voltage of the CAN transceiver has nothing to do with noise. The SN65HVD23x family driver lowers the common-mode output in a dominant bit by a couple hundred millivolts from that of most 5-V drivers. While this does not fully comply with ISO 11898, this small variation in the driver common-mode output is rejected by differential receivers and does not affect data, signal noise margins, or error rates.

### 9.3.1.2 Interoperability Of 3.3-V CAN in 5-V CAN Systems

The 3.3-V-supplied SN65HVD23x family of CAN transceivers are electrically interchangeable with 5-V CAN transceivers. The differential output is the same. The recessive common-mode output is the same. The dominant common-mode output voltage is a couple hundred millivolts lower than 5-V-supplied drivers, while the receivers exhibit identical specifications as 5-V devices.

Electrical interoperability does not assure interchangeability however. Most implementers of CAN buses recognize that ISO 11898 does not sufficiently specify the electrical layer and that strict standard compliance alone does not ensure interchangeability. This comes only with thorough equipment testing.

## 9.4 Device Functional Modes

### 9.4.1 Function Tables

Table 3. Function Table (Driver)<sup>(1)</sup>

DRIVER					
INPUTS			OUTPUTS		
D	LBK	R <sub>s</sub>	CANH	CANL	BUS STATE
X	X	>0.75 V <sub>CC</sub>	Z	Z	Recessive
L	L or open	≤0.33 V <sub>CC</sub>	H	L	Dominant
H or open	X		Z	Z	Recessive
X	H	≤0.33 V <sub>CC</sub>	Z	Z	Recessive

(1) H = high level, L = low level, Z = high impedance, X = irrelevant, ? = indeterminate

Table 4. Function Table (Receiver)

RECEIVER				
INPUTS				OUTPUT
BUS STATE	V <sub>ID</sub> = V <sub>(CANH)</sub> - V <sub>(CANL)</sub>	LBK	D	R
Dominant	V <sub>ID</sub> ≥ 0.9 V	L or open	X	L
Recessive	V <sub>ID</sub> ≤ 0.5 V or open	L or open	H or open	H
?	0.5 V < V <sub>ID</sub> < 0.9 V	L or open	H or open	
X	X	H	L	L
X	X		H	H

### 9.4.2 Equivalent Input and Output Schematic Diagrams

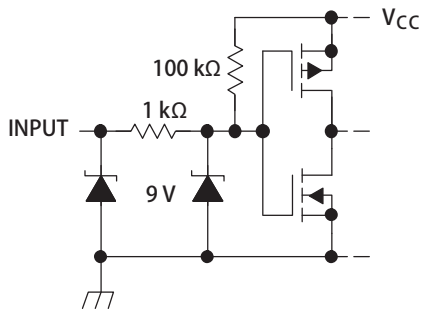

Figure 27. D Input

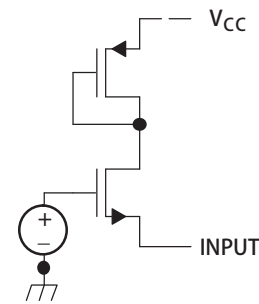

Figure 28. R<sub>s</sub> Input

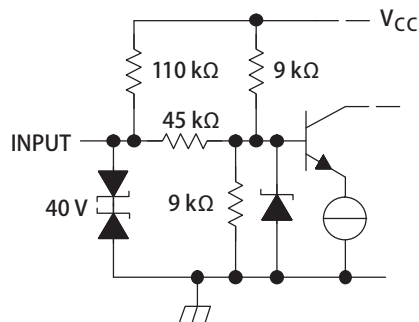

Figure 29. CANH Input

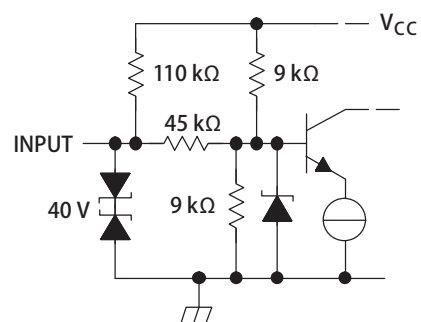
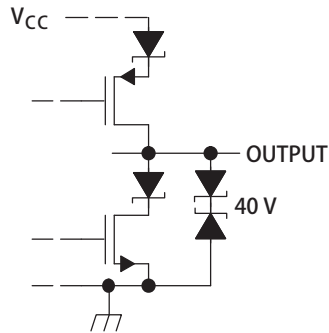
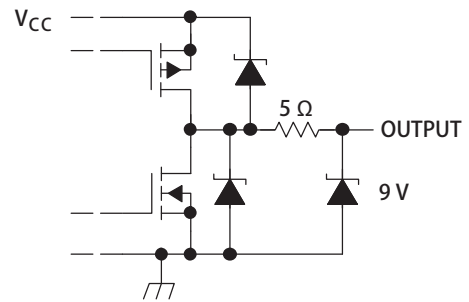

Figure 30. CANL Input



**Figure 31. CANH and CANL Outputs**



**Figure 32. R Output**

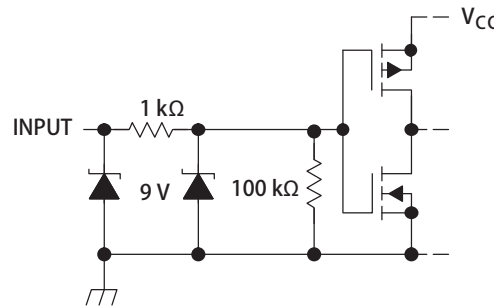

**Figure 33. LBK Input**

## 10 Application and Implementation

### NOTE

Information in the following applications sections is not part of the TI component specification, and TI does not warrant its accuracy or completeness. TI's customers are responsible for determining suitability of components for their purposes. Customers should validate and test their design implementation to confirm system functionality.

### 10.1 Application Information

#### 10.1.1 Diagnostic Loopback

The loopback (LBK) function of the SN65HVD233 is enabled with a high-level input to pin 5. This forces the driver into a recessive state and redirects the data (D) input at pin 1 to the received-data (R) output at pin 4. This allows the host controller to input and read back a bit sequence to perform diagnostic routines without disturbing the CAN bus. A typical CAN bus application is displayed in [Figure 34](#).

If the LBK pin is not used, it may be tied to ground (GND). However, it is pulled low internally (defaults to a low-level input) and may be left open if not in use.

### 10.2 Typical Application

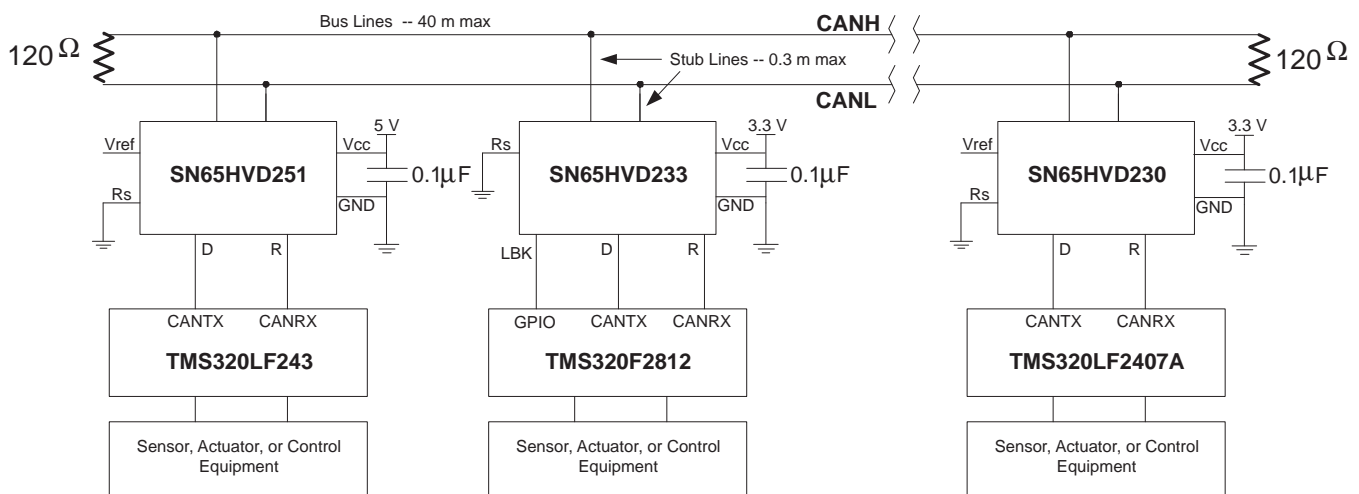

Figure 34. Typical SN65HVD233 Application

#### 10.2.1 Design Requirements

The High-Speed ISO 11898 Standard specifications are given for a maximum signaling rate of 1 Mbps with a bus length of 40 m and a maximum of 30 nodes. It also recommends a maximum un-terminated stub length of 0.3 m. The cable is specified to be a shielded or unshielded twisted-pair with a 120-Ω characteristic impedance (Z<sub>0</sub>). The Standard defines a single line of twisted-pair cable with the network topology as shown in [Figure 34](#). It is terminated at both ends with 120-Ω resistors, which match the characteristic impedance of the line to prevent signal reflections. According to ISO 11898, placing RL on a node should be avoided because the bus lines lose termination if the node is disconnected from the bus.

## Typical Application (continued)

### 10.2.2 Detailed Design Procedure

**Table 5. Suggested Cable Length vs Signaling Rate**

BUS LENGTH (m)	SIGNALING RATE (Mbps)
40	1
100	0.5
200	0.25
500	0.10
1000	0.05

Basically, the maximum bus length is determined by, or rather is a trade-off with the selected signaling rate as listed in [Table 5](#).

A signaling rate decreases as transmission distance increases. While steady-state losses may become a factor at the longest transmission distances, the major factors limiting signaling rate as distance is increased are time varying. Cable bandwidth limitations, which degrade the signal transition time and introduce inter-symbol interference (ISI), are primary factors reducing the achievable signaling rate when transmission distance is increased.

For a CAN bus, the signaling rate is also determined from the total system delay – down and back between the two most distant nodes of a system and the sum of the delays into and out of the nodes on a bus with the typical 5ns/m prop delay of a twisted-pair cable. Also, consideration must be given the signal amplitude loss due to resistance of the cable and the input resistance of the transceivers. Under strict analysis, skin effects, proximity to other circuitry, dielectric loss, and radiation loss effects all act to influence the primary line parameters and degrade the signal.

A conservative rule of thumb for bus lengths over 100 m is derived from the product of the signaling rate in Mbps and the bus length in meters, which should be less than or equal to 50.

Signaling Rate (Mbps) × Bus Length (m) ≤ 50. Operation at extreme temperatures should employ additional conservatism.

#### 10.2.2.1 Slope Control

The rise and fall slope of the SN65HVD233 driver output can be adjusted by connecting a resistor from  $R_s$  (pin 8) to ground (GND), or to a low-level input voltage (see [Figure 35](#)).

The slope of the driver output signal is proportional to the output current of the pin. This slope control is implemented with an external resistor value of 10 kΩ to achieve a  $\approx 15\text{-V}/\mu\text{s}$  slew rate, and up to 100 kΩ to achieve a  $\approx 2.0\text{-V}/\mu\text{s}$  slew rate (see [Figure 36](#)). Typical driver output waveforms with slope control are displayed in [Figure 37](#).

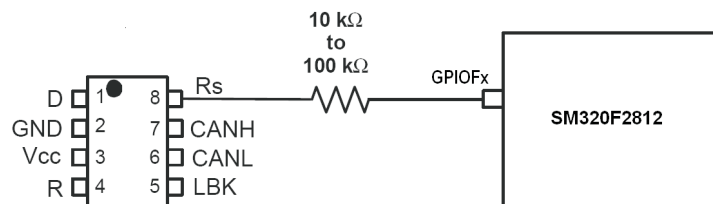
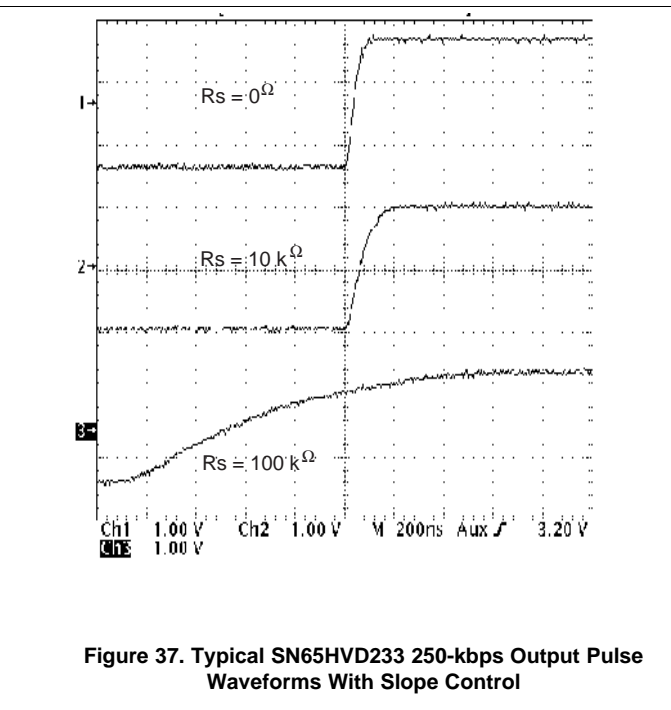
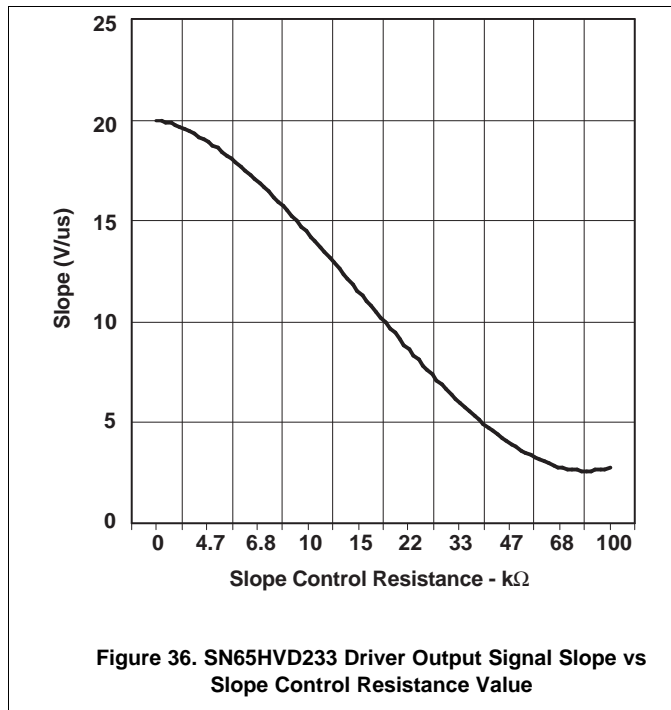

**Figure 35. Slope Control/Standby Connection to DSP**

#### 10.2.2.2 Standby

If a high-level input ( $>0.75 V_{CC}$ ) is applied to  $R_s$ , the circuit enters a low-current, *listen-only* standby mode, during which the driver is switched off and the receiver remains active. The local controller can reverse this low-power standby mode when the rising edge of a dominant state (bus differential voltage  $>900\text{ mV}$  typical) occurs on the bus.

### 10.2.3 Application Curves



## 11 Power Supply Recommendations

TI recommend to have localized capacitive decoupling near device VCC pin to GND. Values of 4.7  $\mu$ F at VCC pin and 10  $\mu$ F, 1 $\mu$ F, and 0.1  $\mu$ F at supply have tested well on evaluation modules.

## 12 Layout

### 12.1 Layout Guidelines

Minimize stub length from node insertion to bus.

## 12.2 Layout Example

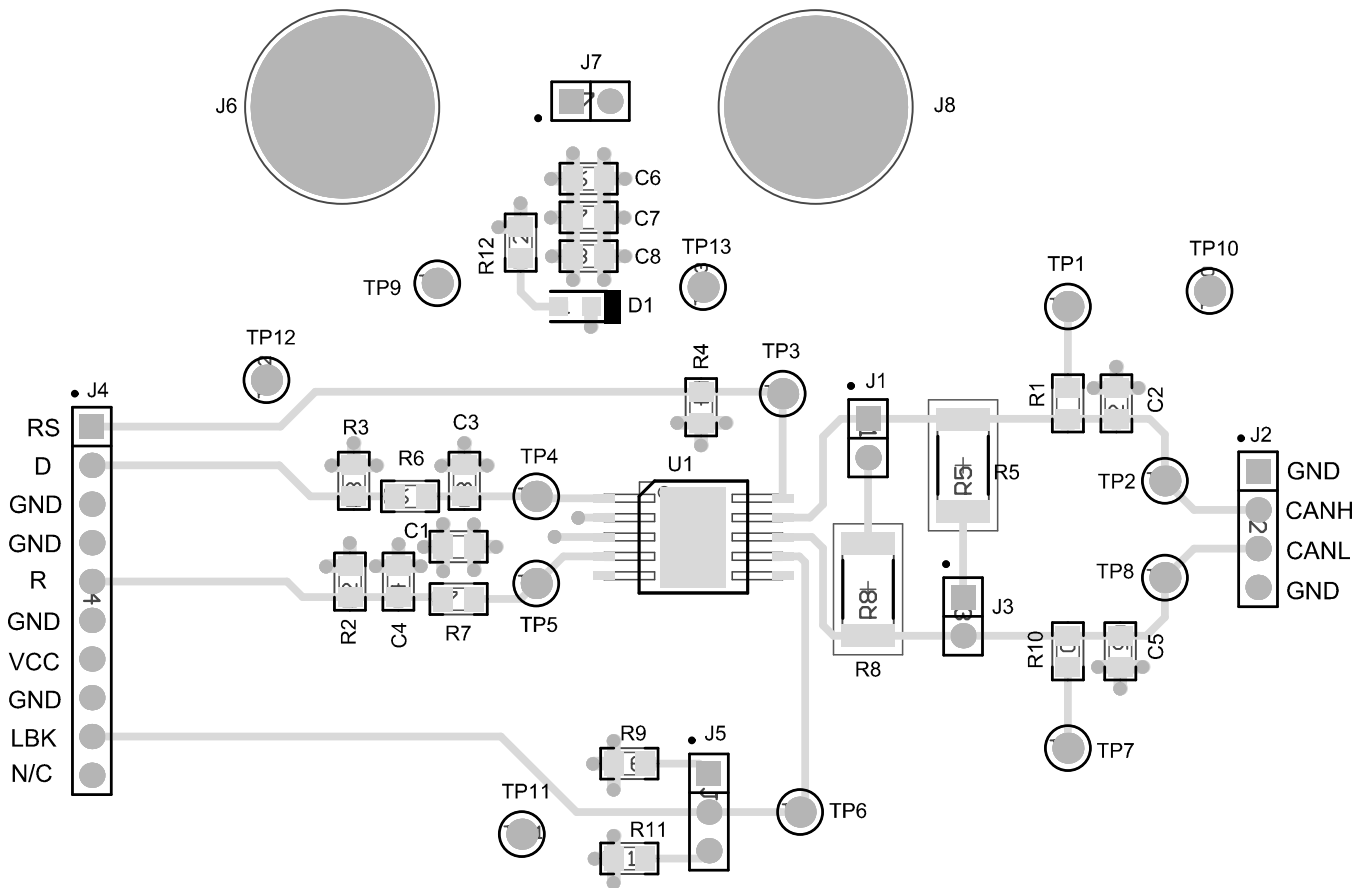

**Figure 38. Layout Example**

## 13 Device and Documentation Support

### 13.1 Trademarks

SDS is a trademark of Texas Instruments.  
DeviceNet is a trademark of Open DeviceNet Vendor Association.  
All other trademarks are the property of their respective owners.

### 13.2 Electrostatic Discharge Caution



These devices have limited built-in ESD protection. The leads should be shorted together or the device placed in conductive foam during storage or handling to prevent electrostatic damage to the MOS gates.

### 13.3 Glossary

[SLYZ022](#) — *TI Glossary*.

This glossary lists and explains terms, acronyms, and definitions.

## 14 Mechanical, Packaging, and Orderable Information

The following pages include mechanical, packaging, and orderable information. This information is the most current data available for the designated devices. This data is subject to change without notice and revision of this document. For browser-based versions of this data sheet, refer to the left-hand navigation.

**PACKAGING INFORMATION**

Orderable Device	Status (1)	Package Type	Package Drawing	Pins	Package Qty	Eco Plan (2)	Lead/Ball Finish (6)	MSL Peak Temp (3)	Op Temp (°C)	Device Marking (4/5)	Samples
SN65HVD233HD	ACTIVE	SOIC	D	8	75	Green (RoHS & no Sb/Br)	CU NIPDAU	Level-1-260C-UNLIM	-55 to 175	233S	<a href="#">Samples</a>
SN65HVD233SHKJ	ACTIVE	CFP	HKJ	8	1	TBD	Call TI	N / A for Pkg Type	-55 to 210	SN65HVD233S HKJ	<a href="#">Samples</a>
SN65HVD233SHKQ	ACTIVE	CFP	HKQ	8	25	TBD	AU	N / A for Pkg Type	-55 to 210	HVD233S HKQ	<a href="#">Samples</a>
SN65HVD233SJD	ACTIVE	CDIP SB	JDJ	8	1	TBD	POST-PLATE	N / A for Pkg Type	-55 to 210	SN65HVD233SJD	<a href="#">Samples</a>
SN65HVD233SKGDA	ACTIVE	XCEPT	KGD	0	130	Green (RoHS & no Sb/Br)	Call TI	N / A for Pkg Type	-55 to 210		<a href="#">Samples</a>

(1) The marketing status values are defined as follows:

**ACTIVE:** Product device recommended for new designs.

**LIFEBUY:** TI has announced that the device will be discontinued, and a lifetime-buy period is in effect.

**NRND:** Not recommended for new designs. Device is in production to support existing customers, but TI does not recommend using this part in a new design.

**PREVIEW:** Device has been announced but is not in production. Samples may or may not be available.

**OBSELETE:** TI has discontinued the production of the device.

(2) **RoHS:** TI defines "RoHS" to mean semiconductor products that are compliant with the current EU RoHS requirements for all 10 RoHS substances, including the requirement that RoHS substance do not exceed 0.1% by weight in homogeneous materials. Where designed to be soldered at high temperatures, "RoHS" products are suitable for use in specified lead-free processes. TI may reference these types of products as "Pb-Free".

**RoHS Exempt:** TI defines "RoHS Exempt" to mean products that contain lead but are compliant with EU RoHS pursuant to a specific EU RoHS exemption.

**Green:** TI defines "Green" to mean the content of Chlorine (Cl) and Bromine (Br) based flame retardants meet JS709B low halogen requirements of <=1000ppm threshold. Antimony trioxide based flame retardants must also meet the <=1000ppm threshold requirement.

(3) MSL, Peak Temp. - The Moisture Sensitivity Level rating according to the JEDEC industry standard classifications, and peak solder temperature.

(4) There may be additional marking, which relates to the logo, the lot trace code information, or the environmental category on the device.

(5) Multiple Device Markings will be inside parentheses. Only one Device Marking contained in parentheses and separated by a "~" will appear on a device. If a line is indented then it is a continuation of the previous line and the two combined represent the entire Device Marking for that device.

(6) Lead/Ball Finish - Orderable Devices may have multiple material finish options. Finish options are separated by a vertical ruled line. Lead/Ball Finish values may wrap to two lines if the finish value exceeds the maximum column width.

**Important Information and Disclaimer:** The information provided on this page represents TI's knowledge and belief as of the date that it is provided. TI bases its knowledge and belief on information provided by third parties, and makes no representation or warranty as to the accuracy of such information. Efforts are underway to better integrate information from third parties. TI has taken and continues to take reasonable steps to provide representative and accurate information but may not have conducted destructive testing or chemical analysis on incoming materials and chemicals. TI and TI suppliers consider certain information to be proprietary, and thus CAS numbers and other limited information may not be available for release.

In no event shall TI's liability arising out of such information exceed the total purchase price of the TI part(s) at issue in this document sold by TI to Customer on an annual basis.

**OTHER QUALIFIED VERSIONS OF SN65HVD233-HT :**

- Catalog: [SN65HVD233](#)
- Automotive: [SN65HVD233-Q1](#)
- Enhanced Product: [SN65HVD233-EP](#)

NOTE: Qualified Version Definitions:

- Catalog - TI's standard catalog product
- Automotive - Q100 devices qualified for high-reliability automotive applications targeting zero defects
- Enhanced Product - Supports Defense, Aerospace and Medical Applications

# MECHANICAL DATA

HKJ (R-CDFP-F8)

CERAMIC DUAL FLATPACK

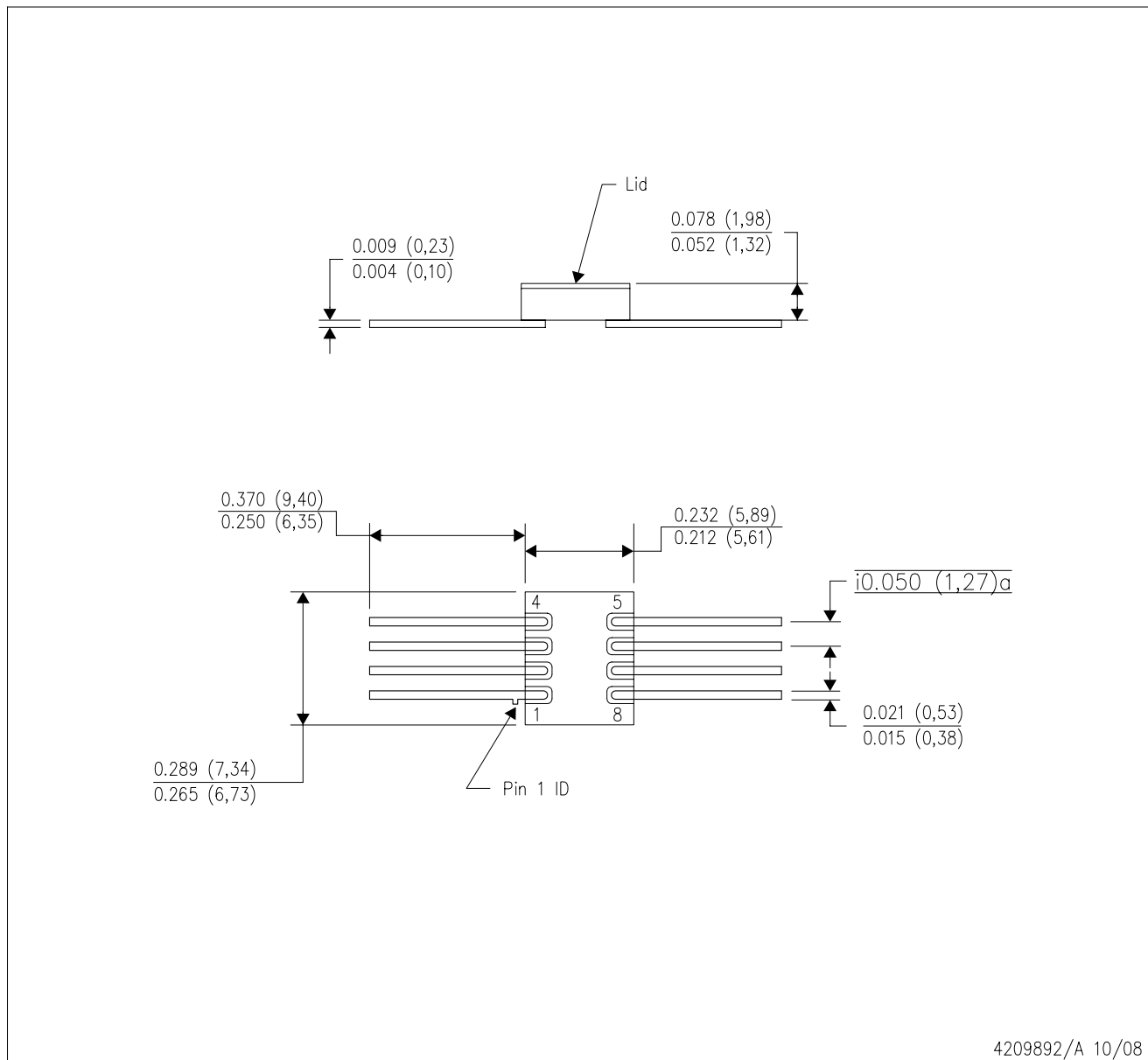

4209892/A 10/08

- NOTES:
- A. All linear dimensions are in inches (millimeters).
  - B. This drawing is subject to change without notice.
  - C. This package can be hermetically sealed with a metal lid.
  - D. The terminals will be gold plated.

# MECHANICAL DATA

HKQ (R-CDFP-G8)

CERAMIC GULL WING

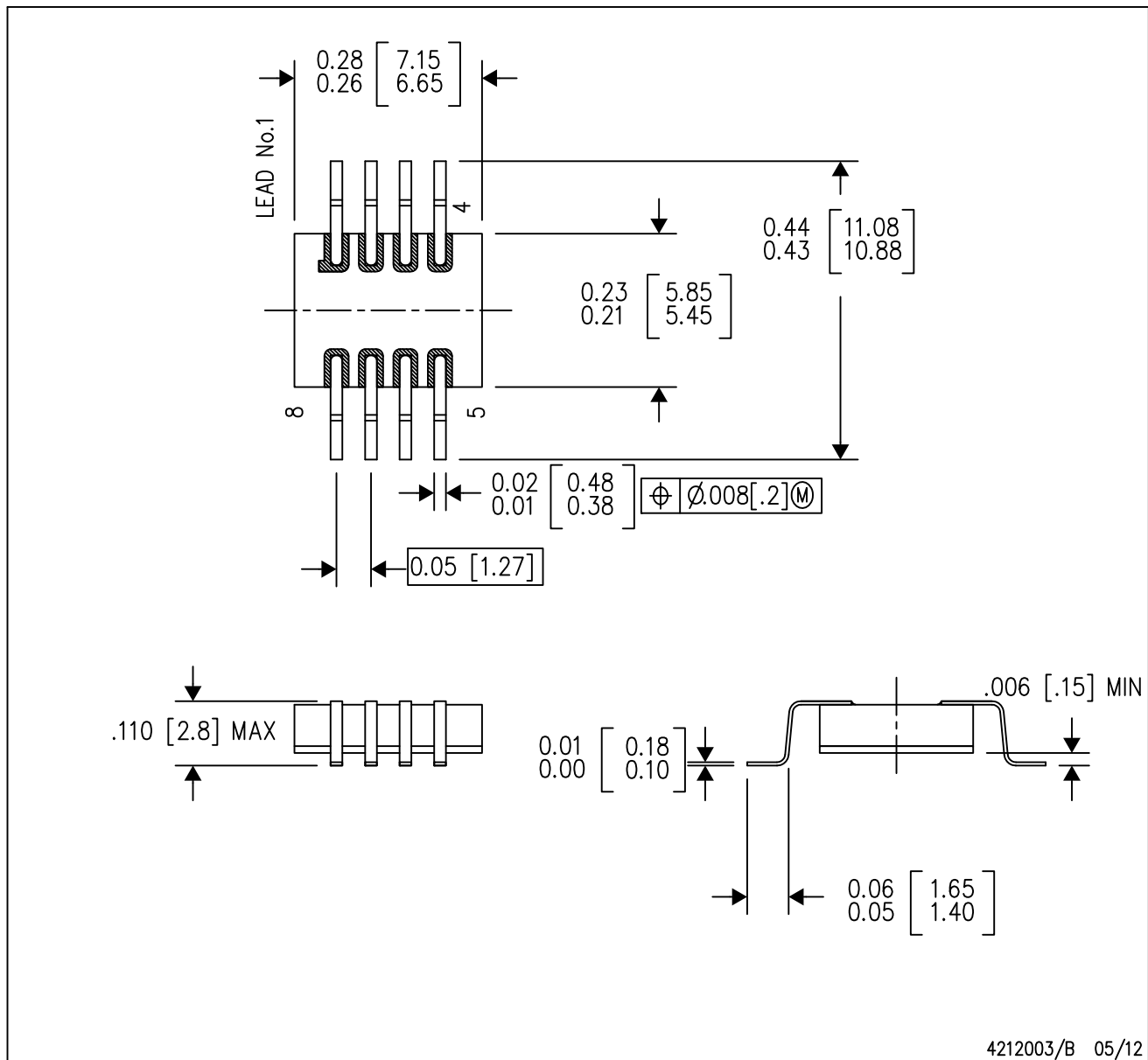

- NOTES:
- All linear dimensions are in inches (millimeters).
  - This drawing is subject to change without notice.
  - This package can be hermetically sealed with a metal lid.
  - The terminals will be gold plated.
  - Lid is not connected to any lead.

JDJ (R-CDIP-T8)

CERAMIC DUAL IN-LINE PACKAGE

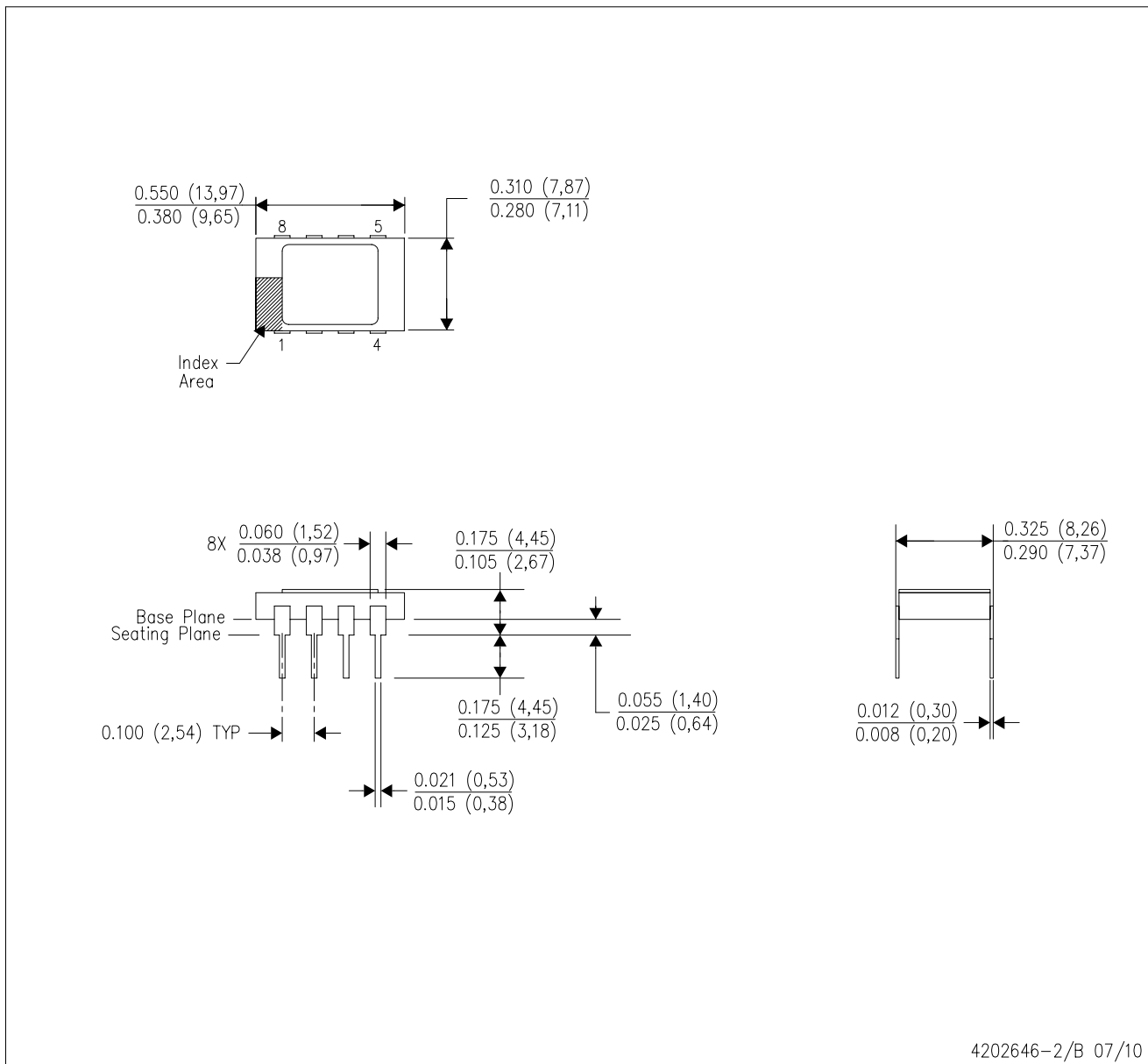

- NOTES:
- All linear dimensions are in inches (millimeters).
  - This drawing is subject to change without notice.
  - Ceramic quad flatpack with flat leads brazed to non-conductive tie bar carrier.
  - This package is hermetically sealed with a metal lid.
  - The leads are gold plated and can be solderdipped.
  - Leads not shown for clarity purposes.
  - Lid and heat sink are connected to GND leads.



D0008A

# PACKAGE OUTLINE

SOIC - 1.75 mm max height

SMALL OUTLINE INTEGRATED CIRCUIT



### NOTES:

1. Linear dimensions are in inches [millimeters]. Dimensions in parenthesis are for reference only. Controlling dimensions are in inches. Dimensioning and tolerancing per ASME Y14.5M.
2. This drawing is subject to change without notice.
3. This dimension does not include mold flash, protrusions, or gate burrs. Mold flash, protrusions, or gate burrs shall not exceed  $.006$  [0.15] per side.
4. This dimension does not include interlead flash.
5. Reference JEDEC registration MS-012, variation AA.

# EXAMPLE BOARD LAYOUT

D0008A

SOIC - 1.75 mm max height

SMALL OUTLINE INTEGRATED CIRCUIT



LAND PATTERN EXAMPLE  
EXPOSED METAL SHOWN  
SCALE:8X



SOLDER MASK DETAILS

4214825/C 02/2019

NOTES: (continued)

- 6. Publication IPC-7351 may have alternate designs.
- 7. Solder mask tolerances between and around signal pads can vary based on board fabrication site.

# EXAMPLE STENCIL DESIGN

D0008A

SOIC - 1.75 mm max height

SMALL OUTLINE INTEGRATED CIRCUIT



SOLDER PASTE EXAMPLE  
BASED ON .005 INCH [0.125 MM] THICK STENCIL  
SCALE:8X

4214825/C 02/2019

NOTES: (continued)

8. Laser cutting apertures with trapezoidal walls and rounded corners may offer better paste release. IPC-7525 may have alternate design recommendations.
9. Board assembly site may have different recommendations for stencil design.

## IMPORTANT NOTICE AND DISCLAIMER

TI PROVIDES TECHNICAL AND RELIABILITY DATA (INCLUDING DATASHEETS), DESIGN RESOURCES (INCLUDING REFERENCE DESIGNS), APPLICATION OR OTHER DESIGN ADVICE, WEB TOOLS, SAFETY INFORMATION, AND OTHER RESOURCES "AS IS" AND WITH ALL FAULTS, AND DISCLAIMS ALL WARRANTIES, EXPRESS AND IMPLIED, INCLUDING WITHOUT LIMITATION ANY IMPLIED WARRANTIES OF MERCHANTABILITY, FITNESS FOR A PARTICULAR PURPOSE OR NON-INFRINGEMENT OF THIRD PARTY INTELLECTUAL PROPERTY RIGHTS.

These resources are intended for skilled developers designing with TI products. You are solely responsible for (1) selecting the appropriate TI products for your application, (2) designing, validating and testing your application, and (3) ensuring your application meets applicable standards, and any other safety, security, or other requirements. These resources are subject to change without notice. TI grants you permission to use these resources only for development of an application that uses the TI products described in the resource. Other reproduction and display of these resources is prohibited. No license is granted to any other TI intellectual property right or to any third party intellectual property right. TI disclaims responsibility for, and you will fully indemnify TI and its representatives against, any claims, damages, costs, losses, and liabilities arising out of your use of these resources.

TI's products are provided subject to TI's Terms of Sale ([www.ti.com/legal/termsofsale.html](http://www.ti.com/legal/termsofsale.html)) or other applicable terms available either on [ti.com](http://ti.com) or provided in conjunction with such TI products. TI's provision of these resources does not expand or otherwise alter TI's applicable warranties or warranty disclaimers for TI products.

Mailing Address: Texas Instruments, Post Office Box 655303, Dallas, Texas 75265  
Copyright © 2019, Texas Instruments Incorporated

## Looking for pricing, stock, or lifecycle information?

Click below to explore more details on WIN SOURCE:

 [View SN65HVD233SJD on WIN SOURCE](#)

 [Texas Instruments](#) Information

## Optimize Your Supply Chain with WIN SOURCE Solutions

-  Global Sourcing Solution
-  Obsolete Management
-  Cost Control Management
-  Shortage Management
-  Alternative Solution
-  Excess Inventory Management