

RAINHOOD KIT

BUL86012

REV. B

FIG. # 1

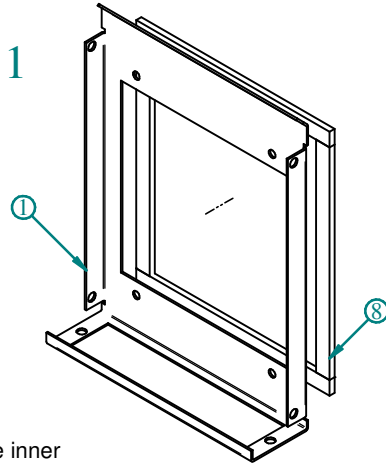

PART #	QTY.	DESCRIPTION
1	1	BASE
2	1	COVER
3	4	BASE SCREW (1/4"-20)
4	4	WASHER
5	4	CLIP NUT
6	4	COVER SCREW (#10-32)
7	4	BASE NUT
8	4	GSK.ROGERS 3/16X1/2

STEP ONE:

- Peel & stick gasket on far side of the inner base plate typ (4) as shown in Fig. # 1.

STEP TWO:

- Mark & drill 92mm x 92 mm cutout & 0.250" ϕ typ (4) & per different model sizes as shown in Fig. # 2.

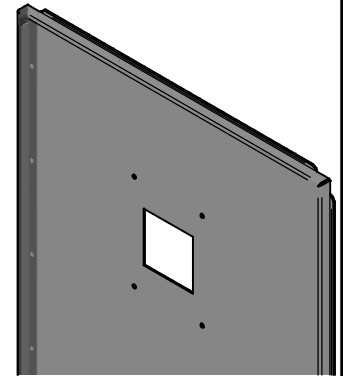

FIG. # 2

MODELS	A	B
RH20000GY, RH20000LG, RH20000SS	5.000	7.000
RH40000GY, RH40000LG, RH40000SS	9.000	11.000
RH60000GY, RH60000LG, RH60000SS	12.000	13.875

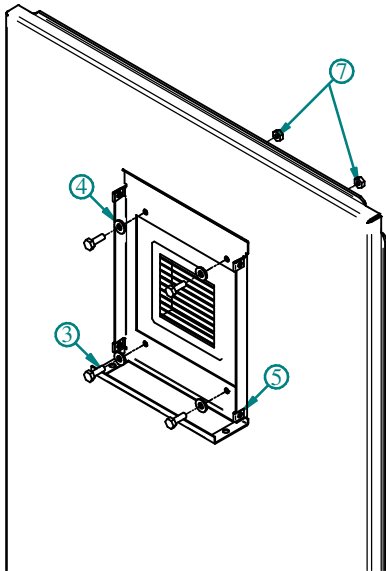
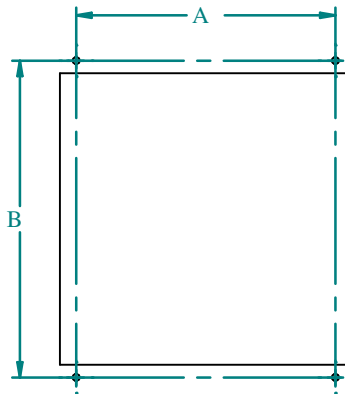

FIG. # 3

STEP THREE:

- Mount inner base plate using screws, washers & nuts supplied.
 - Slip Clip nuts on the boltholes in flanges typ (4) as shown in fig # 3.

STEP FOUR:

- Mount outer cover on base plate using screws provided typ (4) as shown in Fig. # 4.

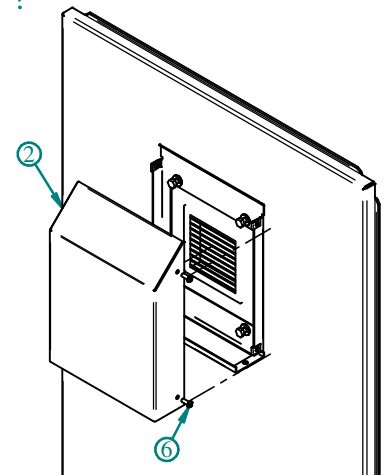



FIG. # 4

TOOL BOX	1/8" Allen Key	Centre Punch	Drill, use .250"	10mm, 17mm, & 9/16" Socket Wrench	7/16 Open End Wrench	Tape Measure

Looking for pricing, stock, or lifecycle information?

Click below to explore more details on WIN SOURCE:

-  [View RH20000GY on WIN SOURCE](#)
-  [Hammond Manufacturing Information](#)

Optimize Your Supply Chain with WIN SOURCE Solutions

-  Global Sourcing Solution
-  Obsolete Management
-  Cost Control Management
-  Shortage Management
-  Alternative Solution
-  Excess Inventory Management