



THE DATASHEET OF LM5114AMF/NOPB



LM5114 Single 7.6-A Peak Current Low-Side Gate Driver

1 Features

- Independent Source and Sink Outputs for Controllable Rise and Fall Times
- 4-V to 12.6-V Single Power Supply
- 7.6-A/1.3-A Peak Sink and Source Drive Current
- 0.23- Ω Open-drain Pulldown Sink Output
- 2- Ω Open-drain Pullup Source Output
- 12-ns (Typical) Propagation Delay
- Matching Delay Time Between Inverting and Noninverting Inputs
- TTL/CMOS Logic Inputs
- 0.68-V Input Hysteresis
- Up to 14-V Logic Inputs (Regardless of VDD Voltage)
- Low Input Capacitance: 2.5-pF (Typical)
- -40°C to 125°C Operating Temperature Range
- Pin-to-Pin Compatible With MAX5048
- 6-Pin SOT-23

2 Applications

- Boost Converters
- Flyback and Forward Converters
- Secondary Synchronous FETs Drive in Isolated Topologies
- Motor Control

3 Description

The LM5114 is designed to drive low-side MOSFETs in boost-type configurations or to drive secondary synchronous MOSFETs in isolated topologies. With strong sink current capability, the LM5114 can drive multiple FETs in parallel. The LM5114 also has the features necessary to drive low-side enhancement mode Gallium Nitride (GaN) FETs. The LM5114 provides inverting and noninverting inputs to satisfy requirements for inverting and Noninverting gate drive in a single device type. The inputs of the LM5114 are TTL/CMOS Logic compatible and withstand input voltages up to 14 V regardless of the VDD voltage. The LM5114 has split gate outputs, providing flexibility to adjust the turnon and turnoff strength independently. The LM5114 has fast switching speed and minimized propagation delays, facilitating high-frequency operation. The LM5114 is available in a 6-pin SOT-23 package and a 6-pin WSON package with an exposed pad to aid thermal dissipation.

Device Information⁽¹⁾

PART NUMBER	PACKAGE	BODY SIZE (NOM)
LM5114	SOT-23 (6)	2.90 mm x 1.60 mm
	WSON (6)	3.00 mm x 3.00 mm

(1) For all available packages, see the orderable addendum at the end of the data sheet.

Block Diagram

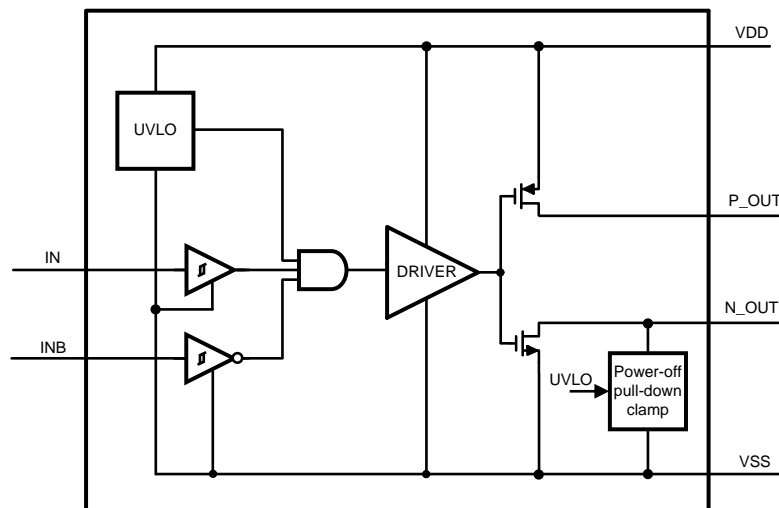

Table of Contents

1 Features 1 2 Applications 1 3 Description 1 4 Revision History 2 5 Device Comparison Table 3 6 Pin Configuration and Functions 3 7 Specifications 4 7.1 Absolute Maximum Ratings 4 7.2 ESD Ratings..... 4 7.3 Recommended Operating Conditions 4 7.4 Thermal Information 4 7.5 Electrical Characteristics 5 7.6 Switching Characteristics 6 7.7 Typical Characteristics 8 8 Detailed Description 12 8.1 Overview 12 8.2 Functional Block Diagram 12	8.3 Feature Description 12 8.4 Device Functional Modes..... 12 9 Application and Implementation 13 9.1 Application Information..... 13 9.2 Typical Application 13 9.3 System Examples 17 10 Power Supply Recommendations 18 11 Layout 18 11.1 Layout Guidelines 18 11.2 Layout Example 18 12 Device and Documentation Support 19 12.1 Community Resources..... 19 12.2 Trademarks 19 12.3 Electrostatic Discharge Caution..... 19 12.4 Glossary 19 13 Mechanical, Packaging, and Orderable Information 19
---	---

4 Revision History

NOTE: Page numbers for previous revisions may differ from page numbers in the current version.

Changes from Revision E (March 2013) to Revision F	Page
<ul style="list-style-type: none"> • Added <i>Pin Configuration and Functions</i> section, <i>ESD Ratings</i> table, <i>Thermal Information</i> table, <i>Feature Description</i> section, <i>Device Functional Modes</i>, <i>Application and Implementation</i> section, <i>Power Supply Recommendations</i> section, <i>Layout</i> section, <i>Device and Documentation Support</i> section, and <i>Mechanical, Packaging, and Orderable Information</i> section 1 	1

Changes from Revision D (August 2012) to Revision E	Page
<ul style="list-style-type: none"> • Changed layout of National Data Sheet to TI format 18 	18

5 Device Comparison Table

BASE PART NUMBER	INPUT THRESHOLDS
LM5114A	CMOS
LM5114B	TTL

6 Pin Configuration and Functions

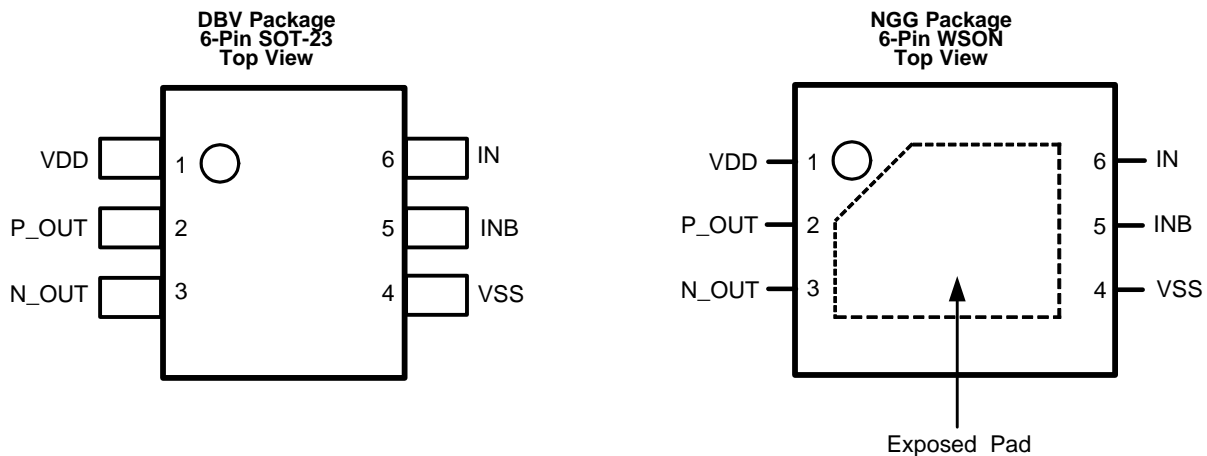

Pin Functions

NAME	PIN		I/O	DESCRIPTION
	SOT-23	WSON		
IN	6	6	I	Noninverting logic input Connect to VDD when not used.
INB	5	5	I	Inverting logic input Connect to VSS when not used.
N_OUT	3	3	O	Sink-current output Connect to the gate of the MOSFET with a short, low inductance path. A gate resistor can be used to adjust the turnoff speed.
P_OUT	2	2	O	Source-current output Connect to the gate of the MOSFET with a short, low inductance path. A gate resistor can be used to adjust the turnon speed.
VDD	1	1	—	Gate drive supply Locally decouple to VSS using low ESR/ESL capacitor located as close as possible to the IC.
VSS	4	4	—	Ground All signals are referenced to this ground.
EP	—	✓	—	It is recommended that the exposed pad on the bottom of the package is soldered to ground plane on the PC board to aid thermal dissipation.

7 Specifications

7.1 Absolute Maximum Ratings

over operating free-air temperature range (unless otherwise noted)⁽¹⁾

	MIN	MAX	UNIT
VDD to VSS	-0.3	14	V
IN, INB to VSS	-0.3	14	V
N_OUT to VSS	-0.3	VDD + 0.3	V
P_OUT to VSS	-0.3	VDD + 0.3	V
Junction temperature		150	°C
Storage temperature, T _{stg}	-55	150	°C

(1) Stresses beyond those listed under *Absolute Maximum Ratings* may cause permanent damage to the device. These are stress ratings only, which do not imply functional operation of the device at these or any other conditions beyond those indicated under *Recommended Operating Conditions*. Exposure to absolute-maximum-rated conditions for extended periods may affect device reliability.

7.2 ESD Ratings

		VALUE	UNIT
V _(ESD) Electrostatic discharge	Human-body model (HBM), per ANSI/ESDA/JEDEC JS-001 ⁽¹⁾	±2000	V
	Charged-device model (CDM), per JEDEC specification JESD22-C101 ⁽²⁾	±1000	V

(1) JEDEC document JEP155 states that 500-V HBM allows safe manufacturing with a standard ESD control process.

(2) JEDEC document JEP157 states that 250-V CDM allows safe manufacturing with a standard ESD control process.

7.3 Recommended Operating Conditions

over operating free-air temperature range (unless otherwise noted)

	MIN	NOM	MAX	UNIT
VDD	4		12.6	V
Junction temperature	40		125	°C

7.4 Thermal Information

THERMAL METRIC ⁽¹⁾	LM5114		UNIT
	DBV (SOT-23)	NGG (WSON)	
	6 PINS	6 PINS	
R _{θJA} Junction-to-ambient thermal resistance	108.1	51.0	°C/W
R _{θJC(top)} Junction-to-case (top) thermal resistance	54.2	47.0	°C/W
R _{θJB} Junction-to-board thermal resistance	24.9	25.3	°C/W
ψ _{JT} Junction-to-top characterization parameter	1.3	0.6	°C/W
ψ _{JB} Junction-to-board characterization parameter	23.9	25.4	°C/W
R _{θJC(bot)} Junction-to-case (bottom) thermal resistance	NA	5.8	°C/W

(1) For more information about traditional and new thermal metrics, see the *Semiconductor and IC Package Thermal Metrics* application report, [SPRA953](#).

7.5 Electrical Characteristics

Minimum and Maximum limits are ensured through test, design, or statistical correlation. Typical values represent the most likely parametric norm at $T_J = 25^\circ\text{C}$, and are provided for reference purposes only. Unless otherwise specified, $V_{DD} = 12\text{ V}$ ⁽¹⁾.

PARAMETER		TEST CONDITIONS		MIN	TYP	MAX	UNIT
POWER SUPPLY							
V_{DD}	VDD operating voltage	(T_J) range of -40°C to 125°C		4.0		12.6	V
$UVLO$	VDD undervoltage lockout	VDD Rising	$T_J = 25^\circ\text{C}$		3.6		V
			(T_J) range of -40°C to 125°C	3.25		4.00	
	VDD undervoltage lockout hysteresis				0.4		V
I_{DD}	VDD quiescent current	$I_N = I_{NB} = V_{DD}$	$T_J = 25^\circ\text{C}$		0.95		mA
			(T_J) range of -40°C to 125°C			1.9	
N-CHANNEL OUTPUT							
R_{ON-N} (SOT-23-6)	Driver output resistance – pulling down	$V_{DD} = 10\text{ V}$, $I_{N-OUT} = -100\text{ mA}$	$T_J = 25^\circ\text{C}$		0.23	0.26	Ω
			$T_J = 125^\circ\text{C}$		0.38	0.43	Ω
		$V_{DD} = 4.5\text{ V}$, $I_{N-OUT} = -100\text{ mA}$	$T_J = 25^\circ\text{C}$		0.24	0.28	Ω
			$T_J = 125^\circ\text{C}$		0.40	0.47	Ω
R_{ON-N} (WSON-6)	Driver output resistance – pulling down	$V_{DD} = 10\text{ V}$, $I_{N-OUT} = -100\text{ mA}$	$T_J = 25^\circ\text{C}$		0.31	0.34	Ω
			$T_J = 125^\circ\text{C}$		0.46	0.51	Ω
		$V_{DD} = 4.5\text{ V}$, $I_{N-OUT} = -100\text{ mA}$	$T_J = 25^\circ\text{C}$		0.32	0.36	Ω
			$T_J = 125^\circ\text{C}$		0.48	0.55	Ω
	Power-off pulldown resistance	$V_{DD} = 0\text{ V}$, $I_{N-OUT} = -10\text{ mA}$			3.3	10	Ω
	Power-off pulldown clamp voltage	$V_{DD} = 0\text{ V}$, $I_{N-OUT} = -10\text{ mA}$			0.85	1.0	V
I_{LK-N}	Output leakage current	$N_OUT = V_{DD}$	$T_J = 25^\circ\text{C}$		6.85		μA
			(T_J) range of -40°C to 125°C			20	
I_{PK-N}	Peak sink current	$C_L = 10,000\text{ pF}$			7.6		A
P-CHANNEL OUTPUT							
R_{ON-P} (SOT-23-6)	Driver output resistance – pulling up	$V_{DD} = 10\text{ V}$, $I_{P-OUT} = 50\text{ mA}$	$T_J = 25^\circ\text{C}$		2.00	3.00	Ω
			$T_J = 125^\circ\text{C}$		2.85	4.30	Ω
		$V_{DD} = 4.5\text{ V}$, $I_{P-OUT} = 50\text{ mA}$	$T_J = 25^\circ\text{C}$		2.20	3.30	Ω
			$T_J = 125^\circ\text{C}$		3.10	4.70	Ω
R_{ON-P} (WSON-6)	Driver output resistance – pulling up	$V_{DD} = 10\text{ V}$, $I_{P-OUT} = 50\text{ mA}$	$T_J = 25^\circ\text{C}$		2.08	3.08	Ω
			$T_J = 125^\circ\text{C}$		2.93	4.38	Ω
		$V_{DD} = 4.5\text{ V}$, $I_{P-OUT} = 50\text{ mA}$	$T_J = 25^\circ\text{C}$		2.28	3.38	Ω
			$T_J = 125^\circ\text{C}$		3.18	4.78	Ω
I_{LK-P}	Output leakage current	$P_OUT = 0$	$T_J = 25^\circ\text{C}$		0.001		μA
			(T_J) range of -40°C to 125°C			10	
I_{PK-P}	Peak source current	$C_L = 10,000\text{ pF}$			1.3		A
LOGIC INPUT							
V_{IH}	Logic 1 input voltage	LM5114A	(T_J) range of -40°C to 125°C	$0.67 \times V_{DD}$			V
		LM5114B		2.4			V
V_{IL}	Logic 0 input voltage	LM5114A	(T_J) range of -40°C to 125°C		$0.33 \times V_{DD}$		V
		LM5114B			0.8		V

(1) Min and Max limits are 100% production tested at 25°C . Limits over the operating temperature range are ensured through correlation using statistical quality control (SQC) methods. Limits are used to calculate TI's average outgoing quality level (AOQL).

Electrical Characteristics (continued)

Minimum and Maximum limits are ensured through test, design, or statistical correlation. Typical values represent the most likely parametric norm at $T_J = 25^\circ\text{C}$, and are provided for reference purposes only. Unless otherwise specified, $V_{DD} = 12\text{ V}$ ⁽¹⁾.

PARAMETER		TEST CONDITIONS		MIN	TYP	MAX	UNIT
LOGIC INPUT (continued)							
V_{HYS}	Logic-input hysteresis	LM5114A		1.6		V	
		LM5114B		0.68		V	
	Logic-input current	INB = VDD or 0	$T_J = 25^\circ\text{C}$ (T_J) range of -40°C to 125°C	0.001		10	μA
C_{IN}	Input capacitance		2.5		pF		

7.6 Switching Characteristics

over operating free-air temperature range (unless otherwise noted)

PARAMETER		TEST CONDITIONS		MIN	TYP	MAX	UNIT
POWER SUPPLY							
UVLO	VDD undervoltage lockout to output delay time	VDD Rising		300		ns	
SWITCHING CHARACTERISTICS FOR VDD = 10 V							
t_R	Rise time	$C_L = 1000\text{ pF}$		8		ns	
		$C_L = 5000\text{ pF}$		45		ns	
		$C_L = 10,000\text{ pF}$		82		ns	
t_F	Fall time	$C_L = 1000\text{ pF}$		3.2		ns	
		$C_L = 5000\text{ pF}$		7.5		ns	
		$C_L = 10,000\text{ pF}$		12.5		ns	
t_{D-ON}	Turnon propagation delay	$C_L = 1000\text{ pF}$	LM5114A	$T_J = 25^\circ\text{C}$	12		ns
				(T_J) range of -40°C to 125°C	5	30	
			LM5114B	$T_J = 25^\circ\text{C}$	12		
				(T_J) range of -40°C to 125°C	6	25	
t_{D-OFF}	Turnoff propagation delay	$C_L = 1000\text{ pF}$	LM5114A	$T_J = 25^\circ\text{C}$	12		ns
				(T_J) range of -40°C to 125°C	5	30	
			LM5114B	$T_J = 25^\circ\text{C}$	12		
				(T_J) range of -40°C to 125°C	6	25	
Break-before-make Time				2.5		ns	
SWITCHING CHARACTERISTICS FOR VDD = 4.5 V							
t_R	Rise time	$C_L = 1000\text{ pF}$		12		ns	
		$C_L = 5000\text{ pF}$		41		ns	
		$C_L = 10,000\text{ pF}$		74		ns	
t_F	Fall time	$C_L = 1000\text{ pF}$		3.0		ns	
		$C_L = 5000\text{ pF}$		7.0		ns	
		$C_L = 10,000\text{ pF}$		11.3		ns	
t_{D-ON}	Turnon propagation delay	$C_L = 1000\text{ pF}$	LM5114A	$T_J = 25^\circ\text{C}$	36		ns
				(T_J) range of -40°C to 125°C	5	17	
			LM5114B	$T_J = 25^\circ\text{C}$	27		
				(T_J) range of -40°C to 125°C	8	14	

Switching Characteristics (continued)

over operating free-air temperature range (unless otherwise noted)

PARAMETER	TEST CONDITIONS		MIN	TYP	MAX	UNIT	
SWITCHING CHARACTERISTICS FOR VDD = 4.5 V (continued)							
t_{D-OFF} Turnoff propagation delay	$C_L = 1000\text{ pF}$	LM5114A	$T_J = 25^\circ\text{C}$			36	
			(T_J) range of -40°C to 125°C	5		17	
		LM5114B	$T_J = 25^\circ\text{C}$			27	ns
			(T_J) range of -40°C to 125°C	8		14	
Break-before-make time				4.2		ns	

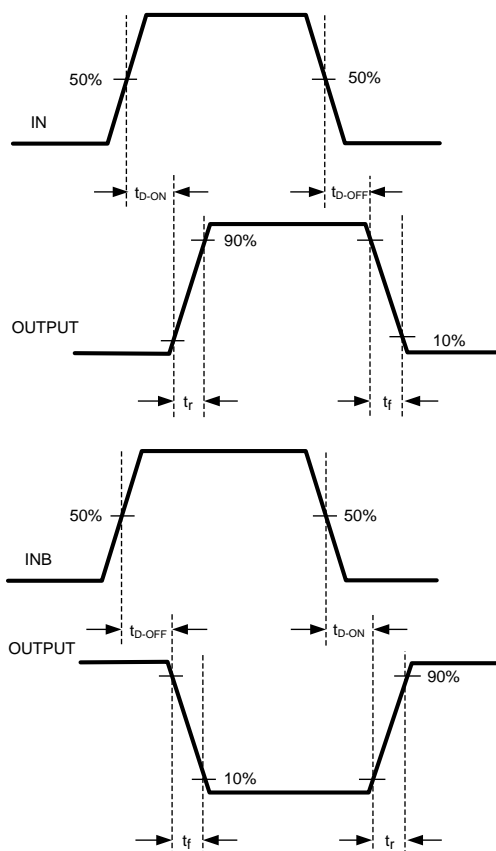

Note: P_OUT and N_OUT are tied together.

Figure 1. Timing Diagram

7.7 Typical Characteristics

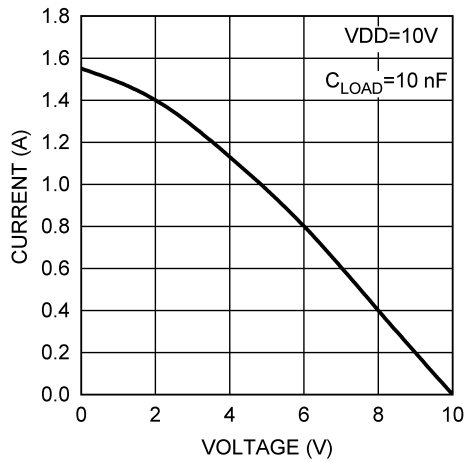

Figure 2. Source Current vs Output Voltage

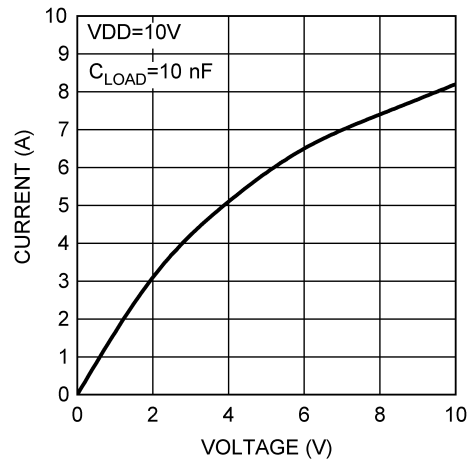

Figure 3. Sink Current vs Output Voltage

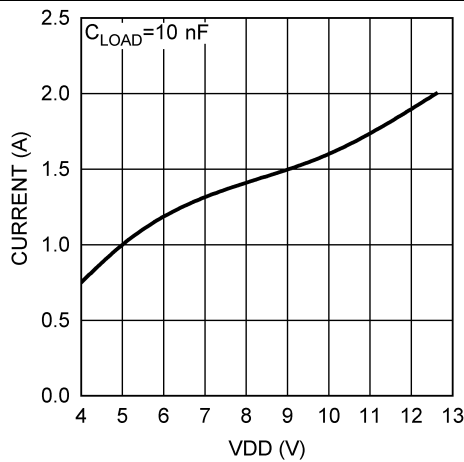

Figure 4. Peak Source Current vs V_{DD} Voltage

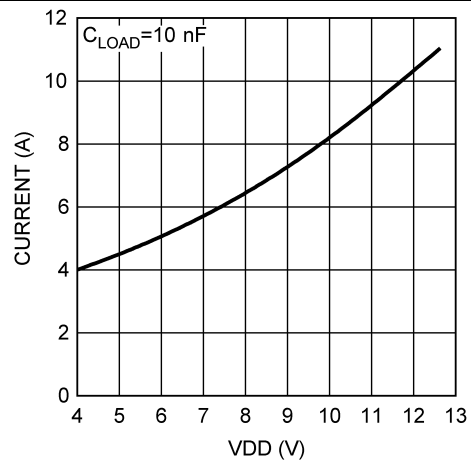

Figure 5. Peak Sink Current vs V_{DD} Voltage

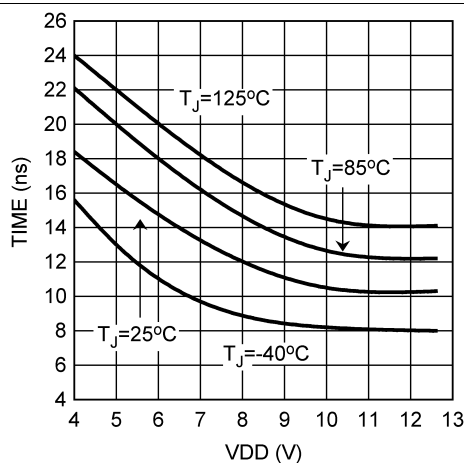

Figure 6. LM5114A Turnon Propagation Delay vs V_{DD}

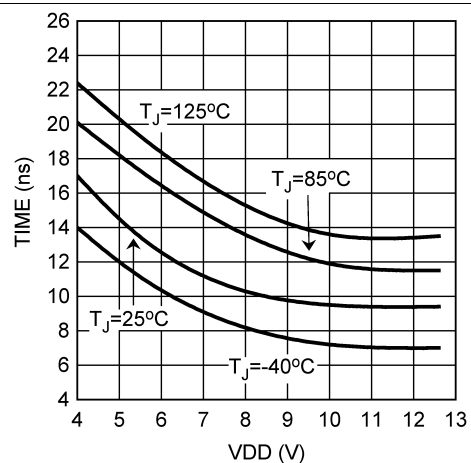

Figure 7. LM5114A Turnoff Propagation Delay vs V_{DD}

Typical Characteristics (continued)

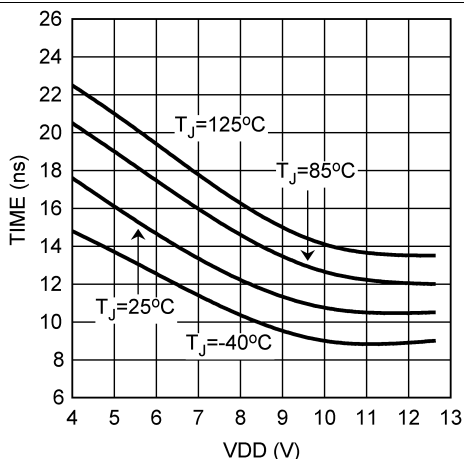

Figure 8. LM5114B Turnon Propagation Delay vs V_{DD}

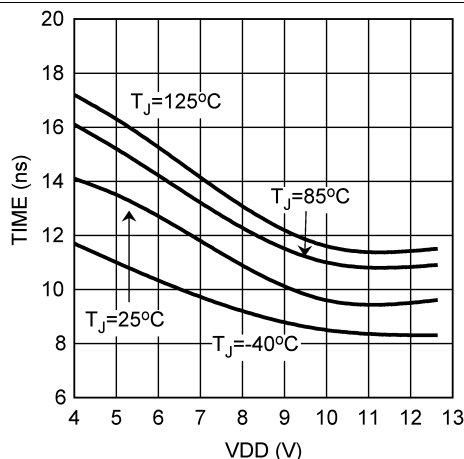

Figure 9. LM5114B Turnoff Propagation Delay vs V_{DD}

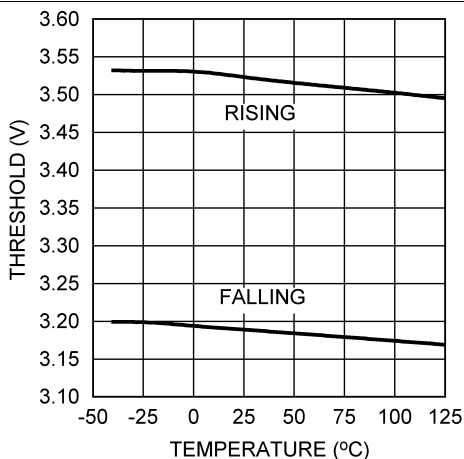

Figure 10. UVLO Threshold vs Temperature

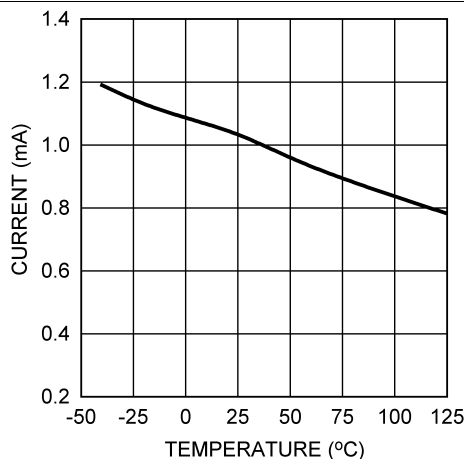

Figure 11. Quiescent Current vs Temperature

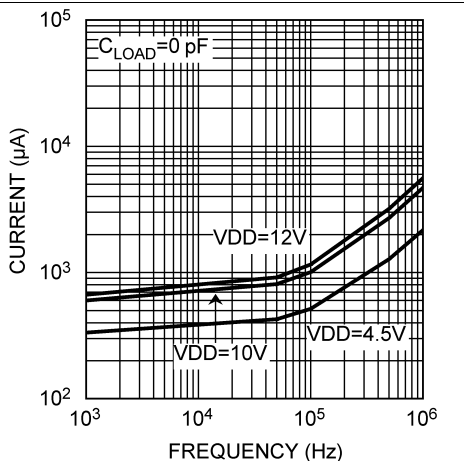

Figure 12. Supply Current vs Frequency

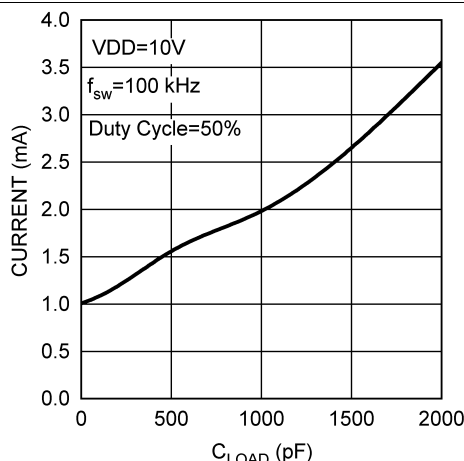

Figure 13. Supply Current vs Capacitive Load

Typical Characteristics (continued)

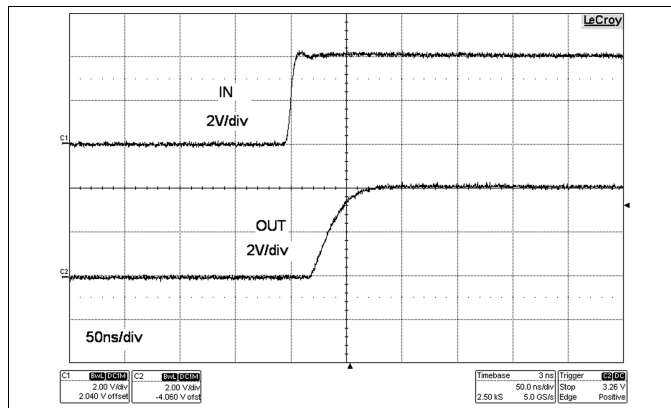

Figure 14. Input Voltage vs Output Voltage ($V_{DD} = 4\text{ V}$, $C_L = 5000\text{ pF}$)

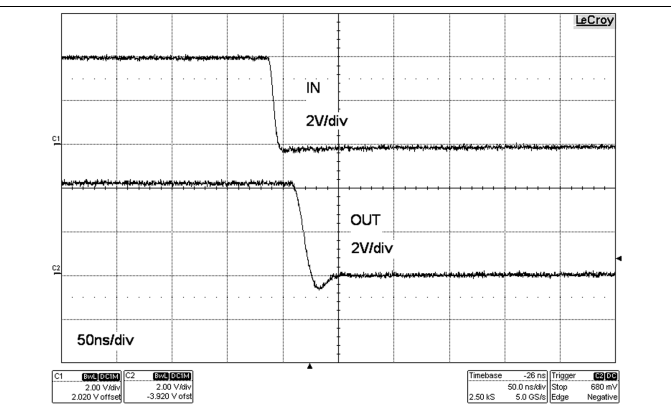

Figure 15. Input Voltage vs Output Voltage ($V_{DD} = 4\text{ V}$, $C_L = 5000\text{ pF}$)

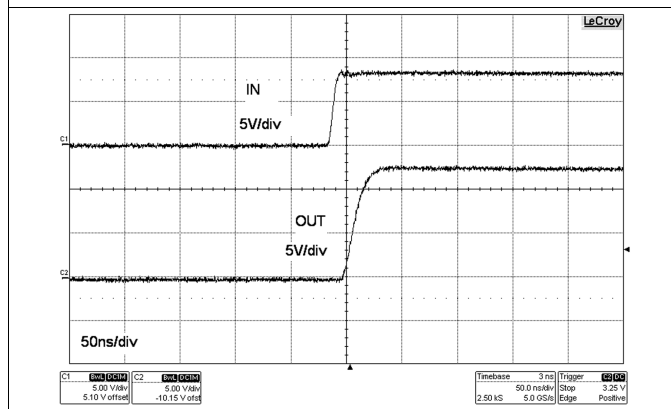

Figure 16. Input Voltage vs Output Voltage ($V_{DD} = 12\text{ V}$, $C_L = 5000\text{ pF}$)

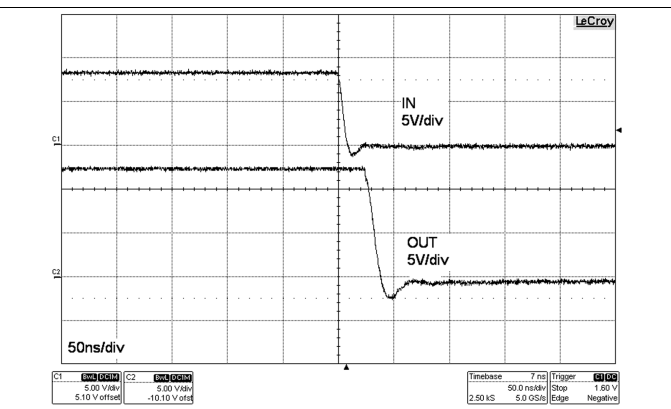

Figure 17. Input Voltage vs Output Voltage ($V_{DD} = 12\text{ V}$, $C_L = 5000\text{ pF}$)

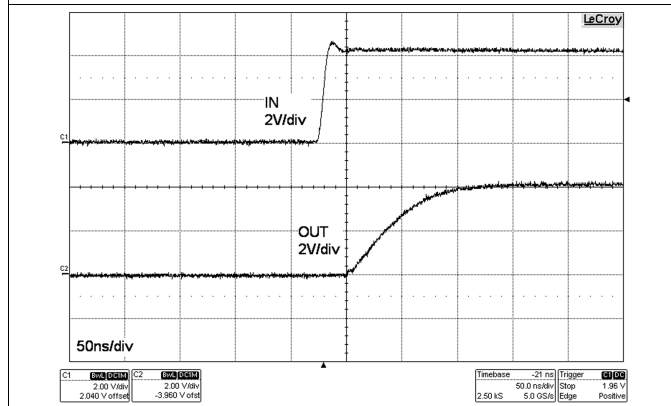

Figure 18. Input Voltage vs Output Voltage ($V_{DD} = 4\text{ V}$, $C_L = 10000\text{ pF}$)

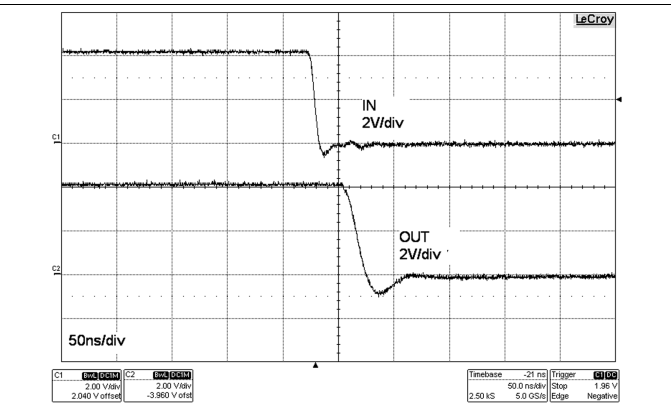
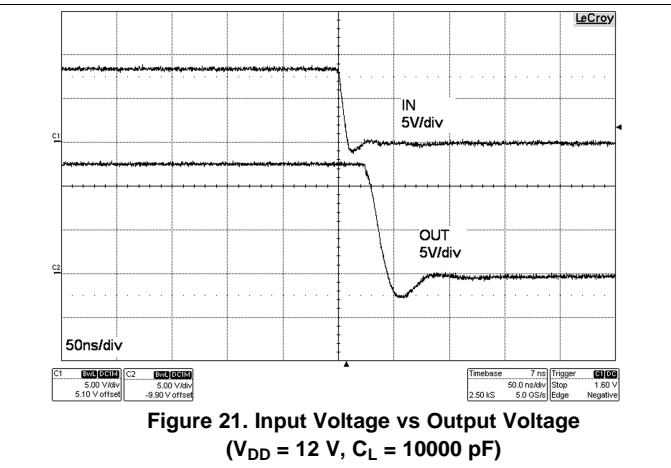
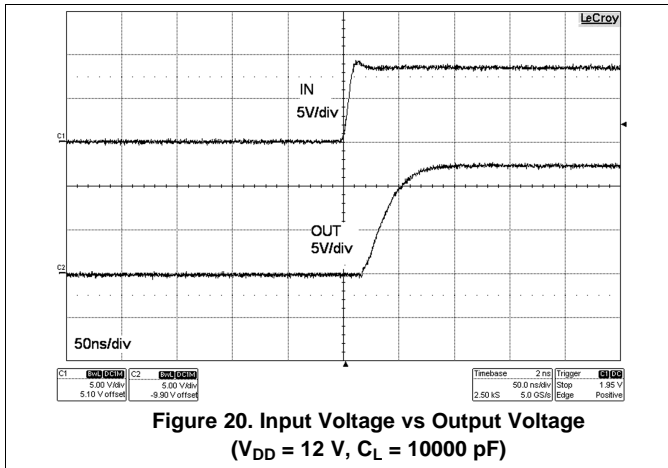

Figure 19. Input Voltage vs Output Voltage ($V_{DD} = 4\text{ V}$, $C_L = 10000\text{ pF}$)

Typical Characteristics (continued)



8 Detailed Description

8.1 Overview

The LM5114 is designed to drive low-side MOSFETs in boost-type configurations or to drive secondary synchronous MOSFETs in isolated topologies. The LM5114 offers both inverting and Noninverting inputs to satisfy requirements for inverting and Noninverting gate drive in a single device type.

8.2 Functional Block Diagram

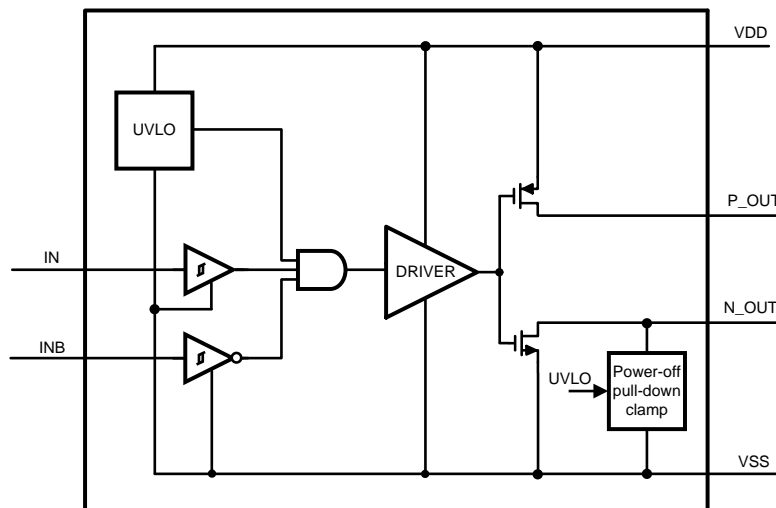

8.3 Feature Description

The LM5114 is a single low-side gate driver with 7.6-A/1.3-A peak sink/source drive current capability. Inputs of the LM5114 are TTL Logic compatible and can withstand the input voltages up to 14-V regardless of the VDD voltage. This allows inputs of the LM5114 to be connected directly to most PWM controllers. The split outputs of the LM5114 offer flexibility to adjust the turnon and turnoff speed independently by adding additional impedance in either the turnon path or the turnoff path.

The LM5114 includes an under-voltage lockout (UVLO) circuit. When the VDD voltage is below the UVLO threshold voltage, the IN and INB inputs are ignored, and if there is sufficient VDD voltage, the output NMOS is turned on to pull the N_OUT low. In addition, the LM5114 has an internal PNP transistor in parallel with the output NMOS. Under the UVLO condition, the PNP transistor will be on and clamp the N_OUT voltage below 1 V.

Under the UVLO condition, the PNP transistor will be on and clamp the N_OUT voltage below 1 V. This feature ensures the N_OUT remaining low when VDD voltage is not sufficient to enhance the output NMOS. The LM5114 has the features necessary to drive low-side enhancement mode GaN FETs. Due to the fast switching speed and relatively low gate voltage of enhancement mode GaN FETs, PCB layout is crucial to achieve reliable operation. Refer to [Layout](#) for details.

8.4 Device Functional Modes

Table 1. Truth Table

IN	INB	P_OUT	N_OUT
L	L	OPEN	L
L	H	OPEN	L
H	L	H	OPEN
H	H	OPEN	L

9 Application and Implementation

NOTE

Information in the following applications sections is not part of the TI component specification, and TI does not warrant its accuracy or completeness. TI's customers are responsible for determining suitability of components for their purposes. Customers should validate and test their design implementation to confirm system functionality.

9.1 Application Information

The LM5114 has the features necessary to drive low-side enhancement mode GaN FETs. Due to the fast switching speed and relatively low gate voltage of enhancement mode GaN FETs, PCB layout is crucial to achieve reliable operation. Refer to [Figure 32](#) for details.

9.2 Typical Application

Boost DC-DC converter using a 100-V enhancement mode GaN FET (EPC2001) as the boost power switch. The control circuitry is implemented with the LM5114, a 100-V current mode PWM controller.

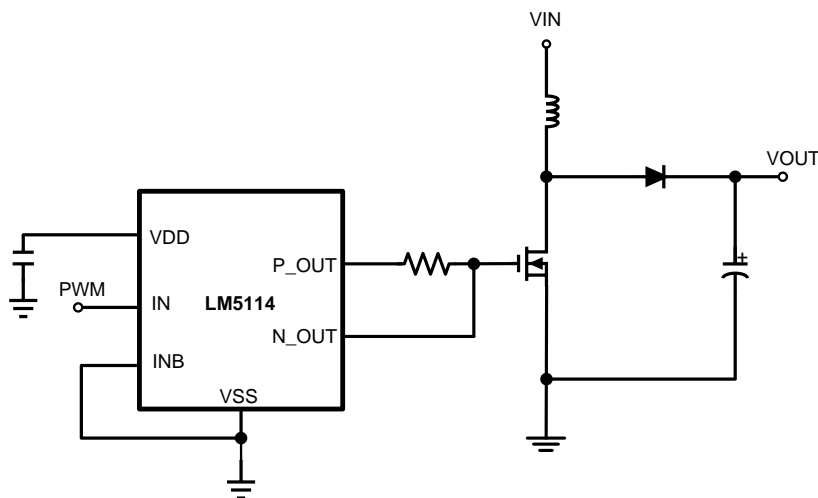

Figure 22. Simplified Boost Converter

Typical Application (continued)

9.2.1 Design Requirements

See [Table 2](#) for the parameter and values.

Table 2. Operating Parameters

PARAMETER	VALUE
Input Operating Voltage	24 V to 66 V
Output Voltage	75 V
Output Current	2 A
Measured Efficiency	97% @ at 48 V 2 A
Frequency of Operation	500 kHz

9.2.1.1 Power Dissipation

It is important to keep the power consumption of the driver below the maximum power dissipation limit of the package at the operating temperature. The total power dissipation of the LM5114 is the sum of the gate charge losses and the losses in the driver due to the internal CMOS stages used to buffer the output as well as the power losses associated with the quiescent current.

The gate charge losses can be calculated with the total input gate charge as in [Equation 1](#) and [Equation 2](#):

$$P_g = Q_g \times V_{DD} \times F_{sw} \quad (1)$$

or

$$P_g = C_{LOAD} \times V_{DD}^2 \times F_{sw}$$

where

- F_{sw} is switching frequency (2)

The power dissipation associated with the internal circuit operation of the driver can be estimated with the characterization curves of the LM5114. For a given ambient temperature, the maximum allowable power loss of the IC can be defined as [Equation 3](#):

$$P = \frac{(T_J - T_A)}{\theta_{JA}}$$

where

- P is the total power dissipation of the driver (3)

This power P_g is dissipated in the resistive elements of the circuit when the MOSFET/IGBT is being turned on and off. Half of the total power is dissipated when the load capacitor is charged during turnon, and the other half is dissipated when the load capacitor is discharged during turnoff. When no external gate resistor is employed between the driver and MOSFET/IGBT, this power is completely dissipated inside the driver package. With the use of external gate-drive resistors, the power dissipation is shared between the internal resistance of driver and external gate resistor.

9.2.1.1.1 Gate Drive

The enhancement mode GaN FETs have small gate capacitance and low threshold gate voltage. Therefore GaN FETs are prone to gate oscillations induced by PCB parasitic elements. It is necessary to place the driver as close to the GaN FET as possible to minimize the stray inductance. Gate resistors can be used to damp the oscillations and to adjust the switching speed. The LM5114 has split outputs, providing flexibility to adjust the turnon and turnoff strength independently. In the evaluation board, 1.5- Ω and 2.7- Ω gate resistors are used in the turnon and turnoff path respectively.

9.2.2 Detailed Design Procedure

The LM5114 has the features necessary to drive low-side enhancement mode GaN FETs. Due to the fast switching speed and relatively low gate voltage of enhancement mode GaN FETs, PCB layout is crucial to achieve reliable operation.

Generally, the switching speed of the power switch during turnon and turnoff should be as fast as possible in order to minimize switching power losses. The gate driver device must be able to provide the required peak current for achieving the targeted switching speeds with the targeted power switch. The system requirement for the switching speed is typically described in terms of the slew rate of the drain-to-source voltage of the power FET (such as dV_{DS}/dt).

For example, the system requirement in this application might state that a EPC2001 GaN FET must be turned on with a dV_{DS}/dt of 20 V/ns or higher with a DC bus voltage of 75 V.

This requirement means that the entire drain-to-source voltage swing during the FET turnon event (from 75 V in the OFF state to $V_{DS(on)}$ in on state) must be completed in approximately 3.75 ns or less. When the drain-to-source voltage swing occurs, the Miller charge of the power FET (QGD parameter in EPC2001 data sheet is 2.2 nC typical) is supplied by the peak current of gate driver. To achieve the targeted dV_{DS}/dt , the gate driver must be capable of providing the QGD charge in 3.75 ns or less. In other words a peak current of 0.586 A ($= 2.2 \text{ nC} / 2 \text{ ns}$) or higher must be provided by the gate driver.

The LM5114 gate driver is capable of providing 1.3-A peak sourcing current which clearly exceeds the design requirement and has the capability to meet the switching speed needed. The 2.2x overdrive capability provides an extra margin against part-to-part variations in the QGD parameter of the power MOSFET along with additional flexibility to insert external gate resistors and fine tune the switching speed for efficiency versus EMI optimizations. However, in practical designs the parasitic trace inductance in the gate drive circuit of the PCB will have a definitive role to play on the FET switching speed.

The effect of this trace inductance is to limit the di/dt of the output current pulse of the gate driver. In order to illustrate this, consider output current pulse waveform from the gate driver to be approximated to a triangular profile, where the area under the triangle ($\frac{1}{2} \times I_{PEAK} \times \text{time}$) would equal the total gate charge of the power FET (QG parameter in the EPC2001 GaNFET datasheet = 8 nC typical). If the parasitic trace inductance limits the di/dt then a situation may occur in which the full peak current capability of the gate driver is not fully achieved in the time required to deliver the QG required for the GaNFET switching. In other words the time parameter in the equation would dominate and the I_{PEAK} value of the current pulse would be much less than the true peak current capability of the device, while the required QG is still delivered.

Because of this, the desired switching speed may not be realized, even when theoretical calculations indicate the gate driver is capable of achieving the targeted switching speed. Thus, placing the gate driver device very close to the power FET and designing a tight gate drive-loop with minimal PCB trace inductance is important to realize the full peak-current capability of the gate driver.

9.2.3 Application Curves

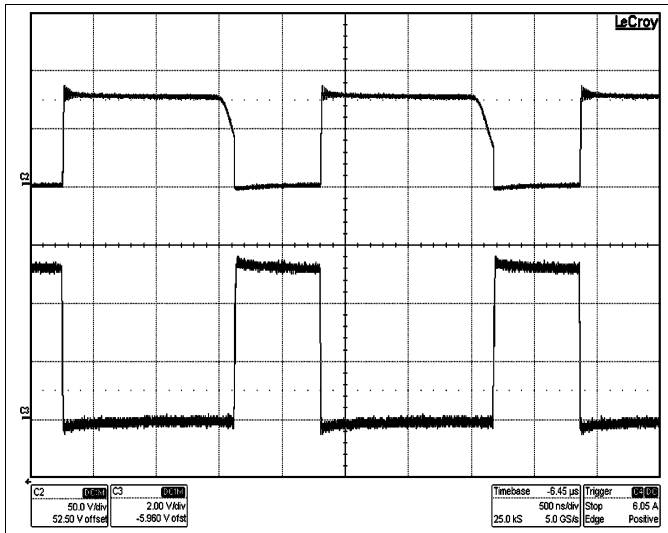

Conditions:

Input Voltage = 48 VDC, Load Current = 2 A

Traces:

Top Trace: Switch-node voltage, Volt/div = 50 V
 Bottom Trace: Gate-Source Voltage of GaN FET, Volt/div = 2 V
 Bandwidth Limit = 600 MHz
 Horizontal Resolution = 500 ns/div

Figure 23. Gate-Source Voltage

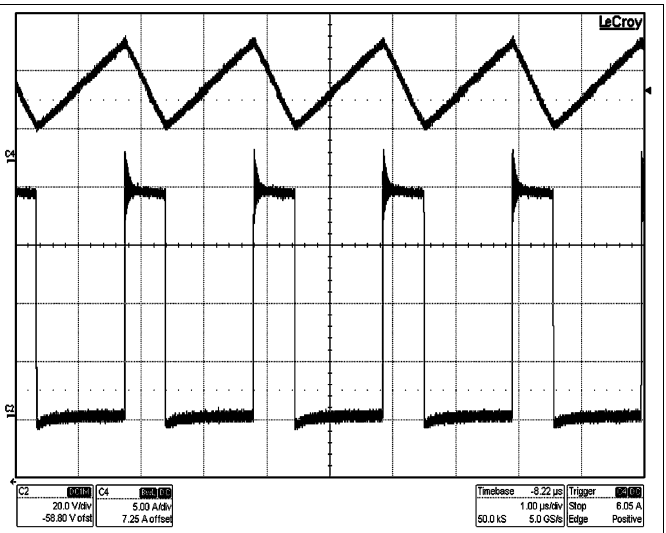

Conditions:

Input Voltage = 24 VDC, Load Current = 2 A

Traces:

Top Trace: Inductor Current, Amp/div = 5 A
 Bottom Trace: Switch-Node Voltage, Volt/div = 20 V
 Bandwidth Limit = 600 MHz
 Horizontal Resolution = 1 μs/div

Figure 24. Switching Node Voltage $V_{IN} = 24$ V, Load Current = 2 A

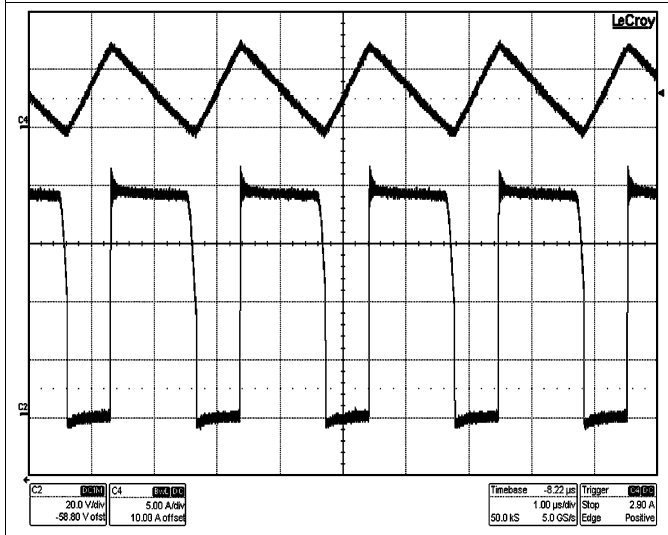

Conditions:

Input Voltage = 48 VDC
 Load Current = 2 A

Traces:

Top Trace: Inductor Current, Amps/div = 5 A
 Bottom Trace: Switch-Node Voltage, Volt/div = 20 V
 Bandwidth Limit = 600 MHz
 Horizontal Resolution = 1 μs/div

Figure 25. Switching Node Voltage $V_{IN} = 48$ V, Load Current = 2 A

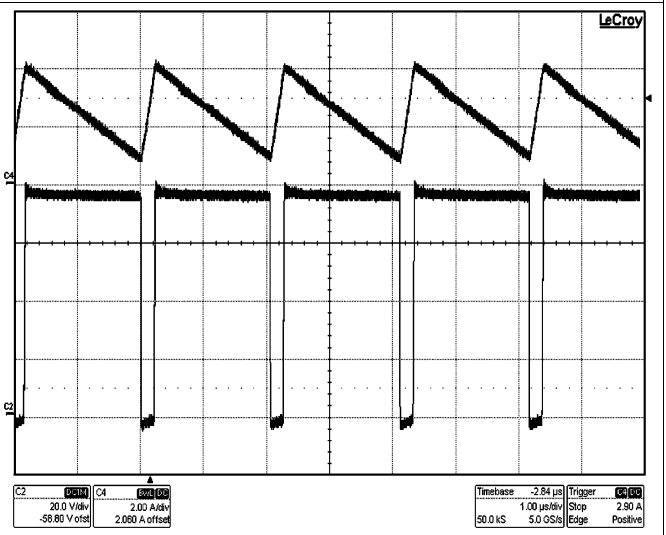

Conditions:

Input Voltage = 66 VDC
 Load Current = 2 A

Traces:

Top Trace: Inductor Current, Amp/div = 5 A
 Bottom Trace: Switch-Node Voltage, Volt/div = 20 V
 Bandwidth Limit = 600 MHz
 Horizontal Resolution = 1 μs/div

Figure 26. Switching Node Voltage $V_{IN} = 66$ V, Load Current = 2 A

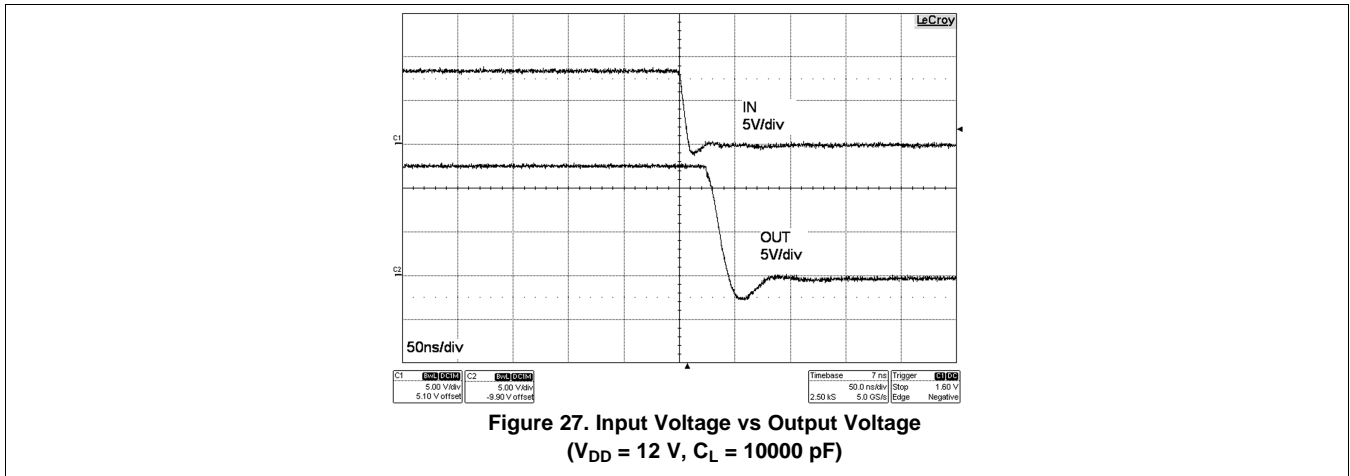

9.3 System Examples

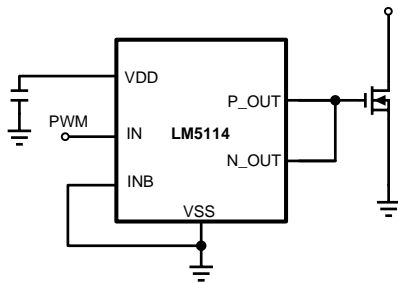

Figure 28. Noninverting Application

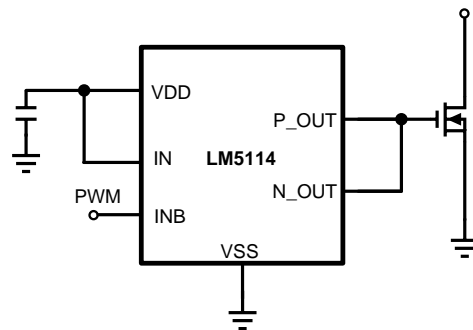

Figure 29. Inverting Application

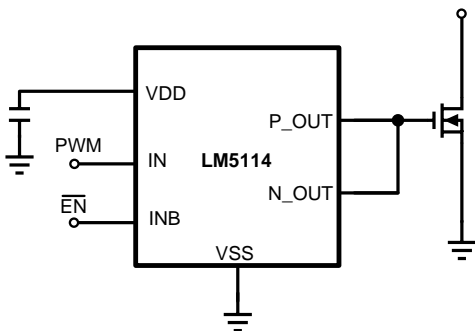

Figure 30. Noninverting Application With Enable Pin

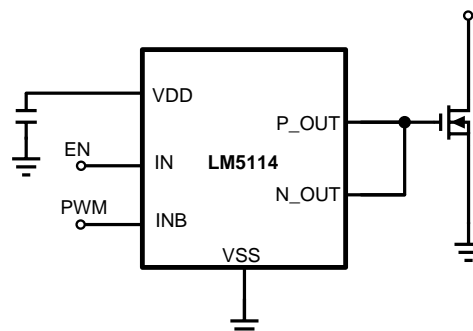

Figure 31. Inverting Application With Enable Pin

10 Power Supply Recommendations

A low-ESR/ESL ceramic capacitor must be connected close to the IC, between V_{DD} and V_{SS} pins to support the high peak current being drawn from V_{DD} during turnon of the FETs. It is most desirable to place the V_{DD} decoupling capacitor on the same side of the PC board as the driver. The inductance of via holes can impose excessive ringing on the IC pins.

11 Layout

11.1 Layout Guidelines

Attention must be given to board layout when using LM5114. Some important considerations include the following:

- The first priority in designing the layout of the driver is to confine the high peak currents that charge and discharge the FETs gate into a minimal physical area. This will decrease the loop inductance and minimize noise issues on the gate.
- To reduce the loop inductance, the driver should be placed as close as possible to the FETs. The gate trace to and from the FETs are recommended to be placed closely side by side, or directly on top of one another.
- The parasitic source inductance, along with the gate capacitor and the driver pulldown path, can form a LCR resonant tank, resulting in gate voltage oscillations. An optional resistor or ferrite bead can be used to damp the ringing.

11.2 Layout Example

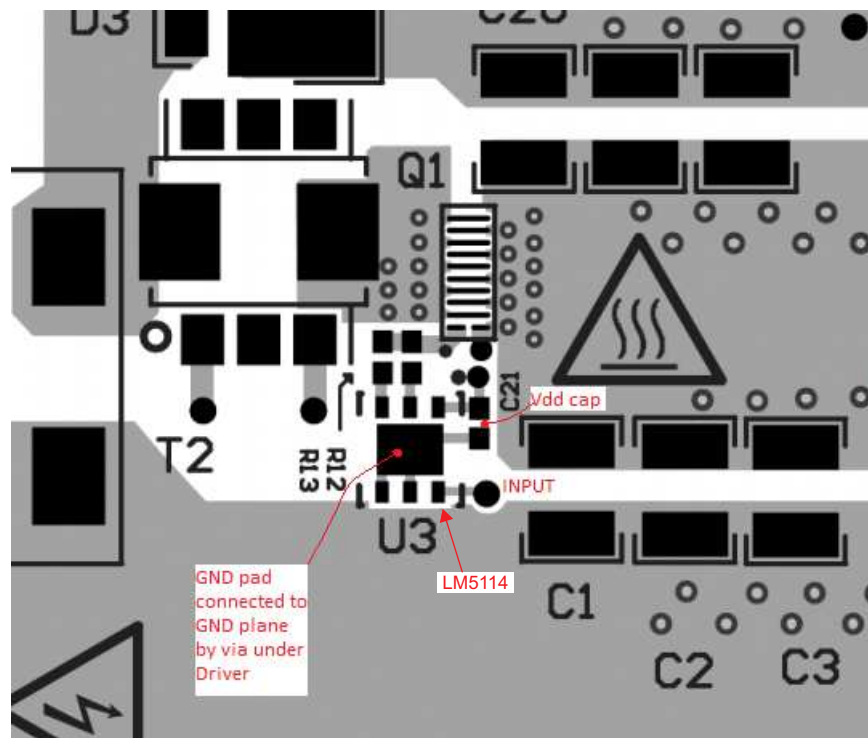

Figure 32. Layout Example

12 Device and Documentation Support

12.1 Community Resources

The following links connect to TI community resources. Linked contents are provided "AS IS" by the respective contributors. They do not constitute TI specifications and do not necessarily reflect TI's views; see TI's [Terms of Use](#).

TI E2E™ Online Community *TI's Engineer-to-Engineer (E2E) Community*. Created to foster collaboration among engineers. At e2e.ti.com, you can ask questions, share knowledge, explore ideas and help solve problems with fellow engineers.

Design Support *TI's Design Support* Quickly find helpful E2E forums along with design support tools and contact information for technical support.

12.2 Trademarks

E2E is a trademark of Texas Instruments.
All other trademarks are the property of their respective owners.

12.3 Electrostatic Discharge Caution



These devices have limited built-in ESD protection. The leads should be shorted together or the device placed in conductive foam during storage or handling to prevent electrostatic damage to the MOS gates.

12.4 Glossary

[SLYZ022](#) — *TI Glossary*.

This glossary lists and explains terms, acronyms, and definitions.

13 Mechanical, Packaging, and Orderable Information

The following pages include mechanical, packaging, and orderable information. This information is the most current data available for the designated devices. This data is subject to change without notice and revision of this document. For browser-based versions of this data sheet, refer to the left-hand navigation.

PACKAGING INFORMATION

Orderable Device	Status (1)	Package Type	Package Drawing	Pins	Package Qty	Eco Plan (2)	Lead/Ball Finish (6)	MSL Peak Temp (3)	Op Temp (°C)	Device Marking (4/5)	Samples
LM5114AMF/NOPB	ACTIVE	SOT-23	DBV	6	1000	Green (RoHS & no Sb/Br)	SN	Level-1-260C-UNLIM	-40 to 125	SL2A	Samples
LM5114AMF/S7003109	ACTIVE	SOT-23	DBV	6	1000	Green (RoHS & no Sb/Br)	SN	Level-1-260C-UNLIM	-40 to 125	SL2A	Samples
LM5114AMFX/NOPB	ACTIVE	SOT-23	DBV	6	3000	Green (RoHS & no Sb/Br)	SN	Level-1-260C-UNLIM	-40 to 125	SL2A	Samples
LM5114AMFX/S7003103	ACTIVE	SOT-23	DBV	6	3000	Green (RoHS & no Sb/Br)	SN	Level-1-260C-UNLIM	-40 to 125	SL2A	Samples
LM5114ASD/NOPB	ACTIVE	WSON	NGG	6	1000	Green (RoHS & no Sb/Br)	CU SN	Level-1-260C-UNLIM	-40 to 125	5114A	Samples
LM5114ASDX/NOPB	ACTIVE	WSON	NGG	6	4500	Green (RoHS & no Sb/Br)	CU SN	Level-1-260C-UNLIM	-40 to 125	5114A	Samples
LM5114BMF/NOPB	ACTIVE	SOT-23	DBV	6	1000	Green (RoHS & no Sb/Br)	SN	Level-1-260C-UNLIM	-40 to 125	SJ4B	Samples
LM5114BMF/S7003094	ACTIVE	SOT-23	DBV	6	1000	Green (RoHS & no Sb/Br)	SN	Level-1-260C-UNLIM	-40 to 125	SJ4B	Samples
LM5114BMF/S7003110	ACTIVE	SOT-23	DBV	6	1000	Green (RoHS & no Sb/Br)	SN	Level-1-260C-UNLIM	-40 to 125	SJ4B	Samples
LM5114BMFX/NOPB	ACTIVE	SOT-23	DBV	6	3000	Green (RoHS & no Sb/Br)	SN	Level-1-260C-UNLIM	-40 to 125	SJ4B	Samples
LM5114BMFX/S7003094	ACTIVE	SOT-23	DBV	6	3000	Green (RoHS & no Sb/Br)	SN	Level-1-260C-UNLIM	-40 to 125	SJ4B	Samples
LM5114BSD/NOPB	ACTIVE	WSON	NGG	6	1000	Green (RoHS & no Sb/Br)	CU SN	Level-1-260C-UNLIM	-40 to 125	5114B	Samples
LM5114BSDX/NOPB	ACTIVE	WSON	NGG	6	4500	Green (RoHS & no Sb/Br)	CU SN	Level-1-260C-UNLIM	-40 to 125	5114B	Samples

(1) The marketing status values are defined as follows:

ACTIVE: Product device recommended for new designs.

LIFEBUY: TI has announced that the device will be discontinued, and a lifetime-buy period is in effect.

NRND: Not recommended for new designs. Device is in production to support existing customers, but TI does not recommend using this part in a new design.

PREVIEW: Device has been announced but is not in production. Samples may or may not be available.

OBSOLETE: TI has discontinued the production of the device.

⁽²⁾ Eco Plan - The planned eco-friendly classification: Pb-Free (RoHS), Pb-Free (RoHS Exempt), or Green (RoHS & no Sb/Br) - please check <http://www.ti.com/productcontent> for the latest availability information and additional product content details.

TBD: The Pb-Free/Green conversion plan has not been defined.

Pb-Free (RoHS): TI's terms "Lead-Free" or "Pb-Free" mean semiconductor products that are compatible with the current RoHS requirements for all 6 substances, including the requirement that lead not exceed 0.1% by weight in homogeneous materials. Where designed to be soldered at high temperatures, TI Pb-Free products are suitable for use in specified lead-free processes.

Pb-Free (RoHS Exempt): This component has a RoHS exemption for either 1) lead-based flip-chip solder bumps used between the die and package, or 2) lead-based die adhesive used between the die and leadframe. The component is otherwise considered Pb-Free (RoHS compatible) as defined above.

Green (RoHS & no Sb/Br): TI defines "Green" to mean Pb-Free (RoHS compatible), and free of Bromine (Br) and Antimony (Sb) based flame retardants (Br or Sb do not exceed 0.1% by weight in homogeneous material)

⁽³⁾ MSL, Peak Temp. - The Moisture Sensitivity Level rating according to the JEDEC industry standard classifications, and peak solder temperature.

⁽⁴⁾ There may be additional marking, which relates to the logo, the lot trace code information, or the environmental category on the device.

⁽⁵⁾ Multiple Device Markings will be inside parentheses. Only one Device Marking contained in parentheses and separated by a "~" will appear on a device. If a line is indented then it is a continuation of the previous line and the two combined represent the entire Device Marking for that device.

⁽⁶⁾ Lead/Ball Finish - Orderable Devices may have multiple material finish options. Finish options are separated by a vertical ruled line. Lead/Ball Finish values may wrap to two lines if the finish value exceeds the maximum column width.

Important Information and Disclaimer: The information provided on this page represents TI's knowledge and belief as of the date that it is provided. TI bases its knowledge and belief on information provided by third parties, and makes no representation or warranty as to the accuracy of such information. Efforts are underway to better integrate information from third parties. TI has taken and continues to take reasonable steps to provide representative and accurate information but may not have conducted destructive testing or chemical analysis on incoming materials and chemicals. TI and TI suppliers consider certain information to be proprietary, and thus CAS numbers and other limited information may not be available for release.

In no event shall TI's liability arising out of such information exceed the total purchase price of the TI part(s) at issue in this document sold by TI to Customer on an annual basis.

TAPE AND REEL INFORMATION

QUADRANT ASSIGNMENTS FOR PIN 1 ORIENTATION IN TAPE

*All dimensions are nominal

Device	Package Type	Package Drawing	Pins	SPQ	Reel Diameter (mm)	Reel Width W1 (mm)	A0 (mm)	B0 (mm)	K0 (mm)	P1 (mm)	W (mm)	Pin1 Quadrant
LM5114AMF/NOPB	SOT-23	DBV	6	1000	178.0	8.4	3.2	3.2	1.4	4.0	8.0	Q3
LM5114AMF/S7003109	SOT-23	DBV	6	1000	178.0	8.4	3.2	3.2	1.4	4.0	8.0	Q2
LM5114AMFX/NOPB	SOT-23	DBV	6	3000	178.0	8.4	3.2	3.2	1.4	4.0	8.0	Q3
LM5114AMFX/S7003103	SOT-23	DBV	6	3000	178.0	8.4	3.2	3.2	1.4	4.0	8.0	Q2
LM5114ASD/NOPB	WSON	NGG	6	1000	178.0	12.4	3.3	3.3	1.0	8.0	12.0	Q1
LM5114ASDX/NOPB	WSON	NGG	6	4500	330.0	12.4	3.3	3.3	1.0	8.0	12.0	Q1
LM5114BMF/NOPB	SOT-23	DBV	6	1000	178.0	8.4	3.2	3.2	1.4	4.0	8.0	Q3
LM5114BMF/S7003094	SOT-23	DBV	6	1000	178.0	8.4	3.2	3.2	1.4	4.0	8.0	Q2
LM5114BMF/S7003110	SOT-23	DBV	6	1000	178.0	8.4	3.2	3.2	1.4	4.0	8.0	Q2
LM5114BMFX/NOPB	SOT-23	DBV	6	3000	178.0	8.4	3.2	3.2	1.4	4.0	8.0	Q3
LM5114BMFX/S7003094	SOT-23	DBV	6	3000	178.0	8.4	3.2	3.2	1.4	4.0	8.0	Q2
LM5114BSD/NOPB	WSON	NGG	6	1000	178.0	12.4	3.3	3.3	1.0	8.0	12.0	Q1
LM5114BSDX/NOPB	WSON	NGG	6	4500	330.0	12.4	3.3	3.3	1.0	8.0	12.0	Q1

TAPE AND REEL BOX DIMENSIONS

*All dimensions are nominal

Device	Package Type	Package Drawing	Pins	SPQ	Length (mm)	Width (mm)	Height (mm)
LM5114AMF/NOPB	SOT-23	DBV	6	1000	210.0	185.0	35.0
LM5114AMF/S7003109	SOT-23	DBV	6	1000	210.0	185.0	35.0
LM5114AMFX/NOPB	SOT-23	DBV	6	3000	210.0	185.0	35.0
LM5114AMFX/S7003103	SOT-23	DBV	6	3000	210.0	185.0	35.0
LM5114ASD/NOPB	WSON	NGG	6	1000	210.0	185.0	35.0
LM5114ASDX/NOPB	WSON	NGG	6	4500	367.0	367.0	35.0
LM5114BMF/NOPB	SOT-23	DBV	6	1000	210.0	185.0	35.0
LM5114BMF/S7003094	SOT-23	DBV	6	1000	210.0	185.0	35.0
LM5114BMF/S7003110	SOT-23	DBV	6	1000	210.0	185.0	35.0
LM5114BMFX/NOPB	SOT-23	DBV	6	3000	210.0	185.0	35.0
LM5114BMFX/S7003094	SOT-23	DBV	6	3000	210.0	185.0	35.0
LM5114BSD/NOPB	WSON	NGG	6	1000	210.0	185.0	35.0
LM5114BSDX/NOPB	WSON	NGG	6	4500	367.0	367.0	35.0

DBV0006A



PACKAGE OUTLINE

SOT-23 - 1.45 mm max height

SMALL OUTLINE TRANSISTOR

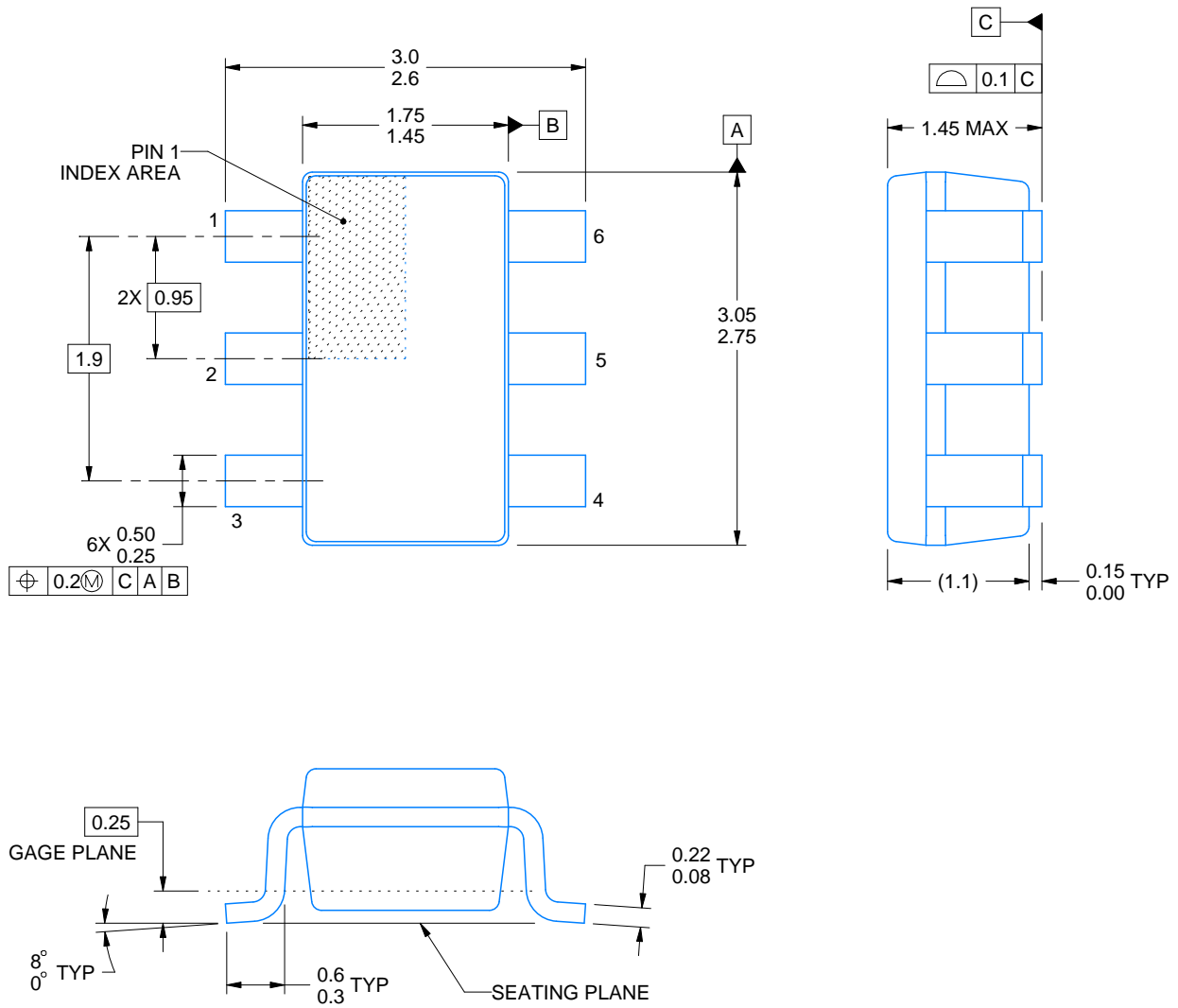

4214840/B 03/2018

NOTES:

1. All linear dimensions are in millimeters. Any dimensions in parenthesis are for reference only. Dimensioning and tolerancing per ASME Y14.5M.
2. This drawing is subject to change without notice.
3. Body dimensions do not include mold flash or protrusion. Mold flash and protrusion shall not exceed 0.15 per side.
4. Leads 1,2,3 may be wider than leads 4,5,6 for package orientation.
5. Reference JEDEC MO-178.

EXAMPLE BOARD LAYOUT

DBV0006A

SOT-23 - 1.45 mm max height

SMALL OUTLINE TRANSISTOR



LAND PATTERN EXAMPLE
EXPOSED METAL SHOWN
SCALE:15X



SOLDER MASK DETAILS

4214840/B 03/2018

NOTES: (continued)

- 6. Publication IPC-7351 may have alternate designs.
- 7. Solder mask tolerances between and around signal pads can vary based on board fabrication site.

EXAMPLE STENCIL DESIGN

DBV0006A

SOT-23 - 1.45 mm max height

SMALL OUTLINE TRANSISTOR



SOLDER PASTE EXAMPLE
BASED ON 0.125 mm THICK STENCIL
SCALE:15X

4214840/B 03/2018

NOTES: (continued)

8. Laser cutting apertures with trapezoidal walls and rounded corners may offer better paste release. IPC-7525 may have alternate design recommendations.
9. Board assembly site may have different recommendations for stencil design.

NGG0006A

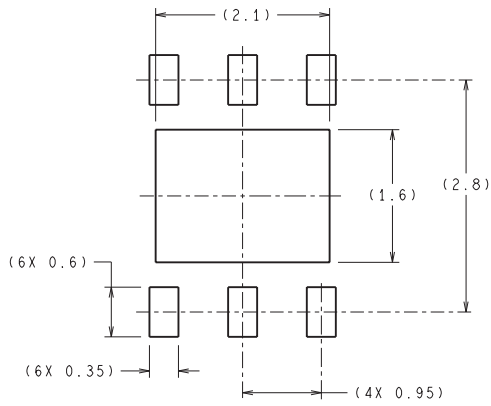

RECOMMENDED LAND PATTERN

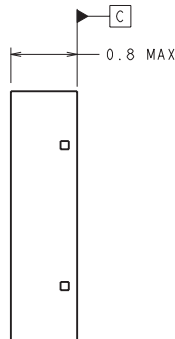
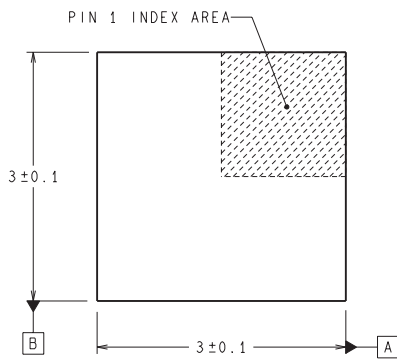

DIMENSIONS ARE IN MILLIMETERS
DIMENSION IN () FOR REFERENCE ONLY

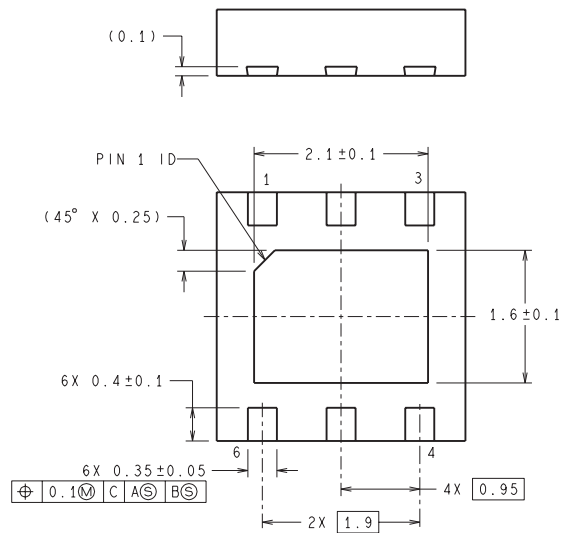

SDE06A (Rev A)

IMPORTANT NOTICE AND DISCLAIMER

TI PROVIDES TECHNICAL AND RELIABILITY DATA (INCLUDING DATASHEETS), DESIGN RESOURCES (INCLUDING REFERENCE DESIGNS), APPLICATION OR OTHER DESIGN ADVICE, WEB TOOLS, SAFETY INFORMATION, AND OTHER RESOURCES "AS IS" AND WITH ALL FAULTS, AND DISCLAIMS ALL WARRANTIES, EXPRESS AND IMPLIED, INCLUDING WITHOUT LIMITATION ANY IMPLIED WARRANTIES OF MERCHANTABILITY, FITNESS FOR A PARTICULAR PURPOSE OR NON-INFRINGEMENT OF THIRD PARTY INTELLECTUAL PROPERTY RIGHTS.

These resources are intended for skilled developers designing with TI products. You are solely responsible for (1) selecting the appropriate TI products for your application, (2) designing, validating and testing your application, and (3) ensuring your application meets applicable standards, and any other safety, security, or other requirements. These resources are subject to change without notice. TI grants you permission to use these resources only for development of an application that uses the TI products described in the resource. Other reproduction and display of these resources is prohibited. No license is granted to any other TI intellectual property right or to any third party intellectual property right. TI disclaims responsibility for, and you will fully indemnify TI and its representatives against, any claims, damages, costs, losses, and liabilities arising out of your use of these resources.

TI's products are provided subject to TI's Terms of Sale (www.ti.com/legal/termsofsale.html) or other applicable terms available either on ti.com or provided in conjunction with such TI products. TI's provision of these resources does not expand or otherwise alter TI's applicable warranties or warranty disclaimers for TI products.

Mailing Address: Texas Instruments, Post Office Box 655303, Dallas, Texas 75265
Copyright © 2019, Texas Instruments Incorporated

Looking for pricing, stock, or lifecycle information?

Click below to explore more details on WIN SOURCE:

 [View LM5114AMF/NOPB on WIN SOURCE](#)

 [Texas Instruments](#) Information

Optimize Your Supply Chain with WIN SOURCE Solutions

-  Global Sourcing Solution
-  Obsolete Management
-  Cost Control Management
-  Shortage Management
-  Alternative Solution
-  Excess Inventory Management