



# RF LDMOS Wideband Integrated Power Amplifier

The MHV5IC1810N wideband integrated circuit is designed with on-chip matching that makes it usable from 1805 to 1990 MHz. This multi-stage structure is rated for 24 to 32 Volt operation and covers all typical cellular base station modulation formats.

## Final Application

- Typical Two-Tone Performance:  $V_{DD} = 28$  Volts,  $I_{DQ1} = 120$  mA,  $I_{DQ2} = 90$  mA,  $P_{out} = 5$  Watts Avg., Full Frequency Band (1805-1880 MHz or 1930-1990 MHz)
  - Power Gain — 29 dB
  - Power Added Efficiency — 29%
  - IMD — -34 dBc

## Driver Application

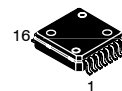
- Typical GSM EDGE Performance:  $V_{DD} = 28$  Volts,  $I_{DQ1} = 105$  mA,  $I_{DQ2} = 95$  mA,  $P_{out} = 35$  dBm, Full Frequency Band (1805-1880 MHz or 1930-1990 MHz)
  - Power Gain — 29 dB
  - Spectral Regrowth @ 400 kHz Offset = -67 dBc
  - Spectral Regrowth @ 600 kHz Offset = -76 dBc
  - EVM — 1.1% rms
- Capable of Handling 3:1 VSWR, @ 28 Vdc, 1990 MHz, 10 Watts CW Output Power
- Stable into a 3:1 VSWR. All Spurs Below -60 dBc @ 100 mW to 10 W CW  $P_{out}$ .

## Features

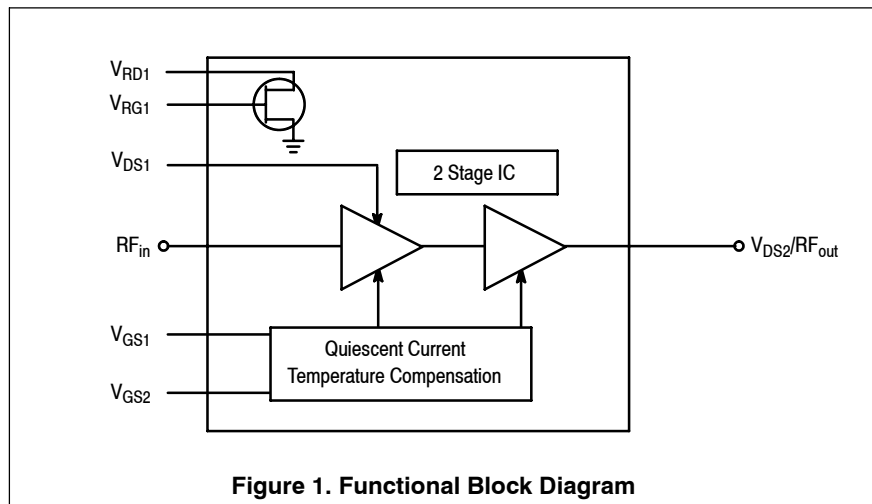
- Characterized with Series Equivalent Large-Signal Impedance Parameters and Common Source Parameters
- On-Chip Matching (50 Ohm Input, >5 Ohm Output)
- Integrated Quiescent Current Temperature Compensation with Enable/Disable Function
- On-Chip Current Mirror  $g_m$  Reference FET for Self Biasing Application (1)
- Integrated ESD Protection
- RoHS Compliant
- In Tape and Reel. R2 Suffix = 1500 Units, 16 mm Tape Width, 13 inch Reel.

**MHV5IC1810NR2**

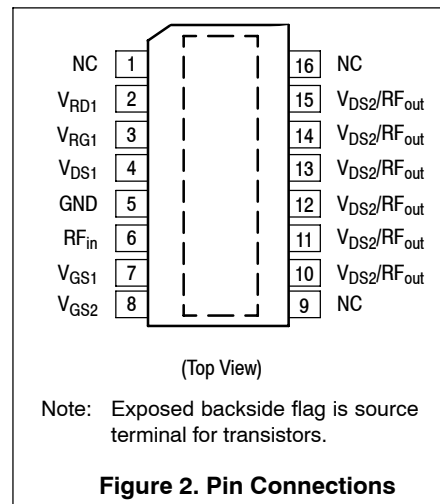
**1805-1990 MHz, 5 W AVG., 28 V  
 GSM/GSM EDGE  
 RF LDMOS WIDEBAND  
 INTEGRATED POWER AMPLIFIER**



**CASE 978-03  
 PFP-16  
 PLASTIC**



**Figure 1. Functional Block Diagram**



(Top View)

Note: Exposed backside flag is source terminal for transistors.

**Figure 2. Pin Connections**

1. Refer to AN1987, *Quiescent Current Control for the RF Integrated Circuit Device Family*. Go to <http://www.freescale.com/rf>. Select Documentation/Application Notes - AN1987.

**Table 1. Maximum Ratings**

Rating	Symbol	Value	Unit
Drain-Source Voltage	$V_{DSS}$	-0.5, +65	Vdc
Gate-Source Voltage	$V_{GS}$	-0.5, +12	Vdc
Storage Temperature Range	$T_{stg}$	-65 to +150	°C
Operating Junction Temperature	$T_J$	150	°C
Input Power	$P_{in}$	12	dBm

**Table 2. Thermal Characteristics**

Characteristic	Symbol	Value (1)	Unit
Thermal Resistance, Junction to Case	$R_{\theta JC}$		°C/W
Final Application ( $P_{out} = 10$ W CW)	Stage 1, 28 Vdc, $I_{DQ1} = 120$ mA Stage 2, 28 Vdc, $I_{DQ2} = 90$ mA	9.2 3.3	
Driver Application ( $P_{out} = 2.25$ W CW)	Stage 1, 28 Vdc, $I_{DQ1} = 120$ mA Stage 2, 28 Vdc, $I_{DQ2} = 90$ mA	10 3.5	

**Table 3. ESD Protection Characteristics**

Test Methodology	Class
Human Body Model (per JESD22-A114)	0 (Minimum)
Machine Model (per EIA/JESD22-A115)	A (Minimum)
Charge Device Model (per JESD22-C101)	III (Minimum)

**Table 4. Moisture Sensitivity Level**

Test Methodology	Rating	Package Peak Temperature	Unit
Per JESD22-A113, IPC/JEDEC J-STD-020	3	260	°C

**Table 5. Electrical Characteristics** ( $T_A = 25^\circ\text{C}$  unless otherwise noted)

Characteristic	Symbol	Min	Typ	Max	Unit
----------------	--------	-----	-----	-----	------

**Functional Tests** (In Freescale Wideband 1930-1990 MHz Test Fixture, 50 ohm system)  $V_{DD} = 28$  Vdc,  $I_{DQ1} = 120$  mA,  $I_{DQ2} = 90$  mA,  $P_{out} = 5$  W Avg.,  $f_1 = 1990$  MHz,  $f_2 = 1990.1$  MHz, Two-Tone Test

Power Gain	$G_{ps}$	26.5	29	—	dB
Power Added Efficiency	PAE	25	29	—	%
Intermodulation Distortion	IMD	—	-34	-27	dBc
Input Return Loss	IRL	—	—	-10	dB

**Typical Two-Tone Performances** (In Freescale Test Fixture, 50 ohm system)  $V_{DD} = 28$  Vdc,  $I_{DQ1} = 120$  mA,  $I_{DQ2} = 90$  mA,  $P_{out} = 5$  W Avg., 1805-1880 MHz

Power Gain	$G_{ps}$	—	29	—	dB
Power Added Efficiency	PAE	—	29	—	%
Intermodulation Distortion	IMD	—	-34	—	dBc
Input Return Loss	IRL	—	-15	—	dB

**Typical GSM EDGE Performances** (In Freescale GSM EDGE Test Fixture, 50 ohm system)  $V_{DD} = 28$  Vdc,  $I_{DQ1} = 105$  mA,  $I_{DQ2} = 95$  mA,  $P_{out} = 3.2$  W Avg., 1805-1880 MHz or 1930-1990 MHz EDGE Modulation

Power Gain	$G_{ps}$	—	29	—	dB
Error Vector Magnitude	EVM	—	1.1	—	% rms
Spectral Regrowth at 400 kHz Offset	SR1	—	-67	—	dBc
Spectral Regrowth at 600 kHz Offset	SR2	—	-76	—	dBc

1. Refer to AN1955, *Thermal Measurement Methodology of RF Power Amplifiers*. Go to <http://www.freescale.com/rf>. Select Documentation/Application Notes - AN1955.

(continued)

**Table 5. Electrical Characteristics** ( $T_A = 25^\circ\text{C}$  unless otherwise noted) **(continued)**

Characteristic	Symbol	Min	Typ	Max	Unit
<b>Typical CW Performances</b> (In Freescale CW Test Fixture, 50 ohm system) $V_{DD} = 28\text{ Vdc}$ , $I_{DQ1} = 120\text{ mA}$ , $I_{DQ2} = 90\text{ mA}$ , $P_{out} = 2.25\text{ W Avg.}$ , 1805-1990 MHz					
Power Gain	$G_{ps}$	—	29	—	dB
Power Added Efficiency	PAE	—	19	—	%
Input Return Loss	IRL	—	-13	—	dB

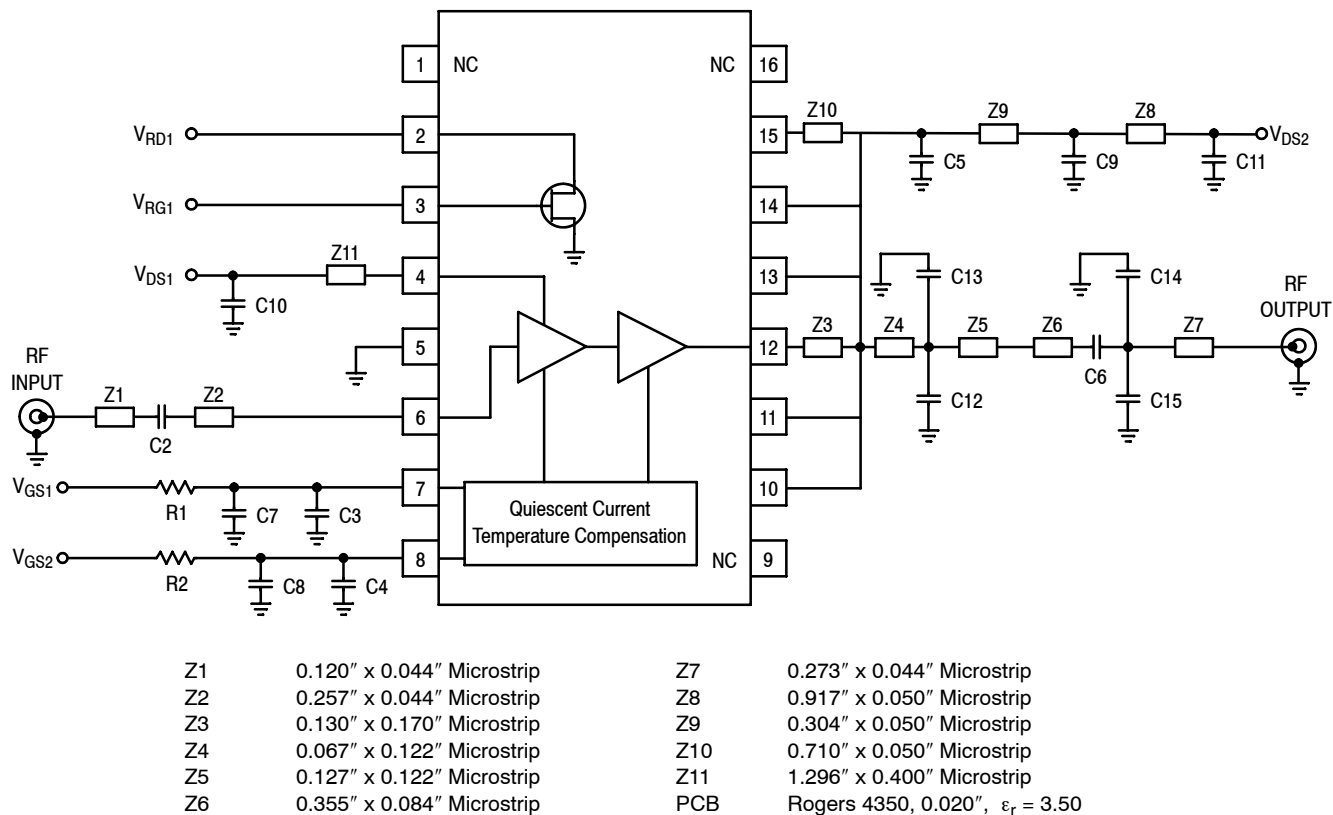


Figure 3. MHV5IC1810NR2 Test Circuit Schematic — 1930-1990 MHz

Table 6. MHV5IC1810NR2 Test Circuit Component Designations and Values — 1930-1990 MHz

Part	Description	Part Number	Manufacturer
C2	22 pF Chip Capacitor	ATC100A220GT500XT	ATC
C3, C4, C5, C6	8.2 pF Chip Capacitors	ATC100A8R2CT500XT	ATC
C7, C8, C9	10 nF Chip Capacitors	08055C103KAT	AVX
C10, C11	6.8 $\mu$ F Chip Capacitors	C4532X5R1H685MT	TDK
C12, C13	3.3 pF Chip Capacitors	ATC100A3R3BT500XT	ATC
C14, C15	0.5 pF Chip Capacitors	ATC100A0R5BT500XT	ATC
R1, R2	1 k $\Omega$ , 1/8 W Chip Resistors	CRCW1K00FKEA	Vishay

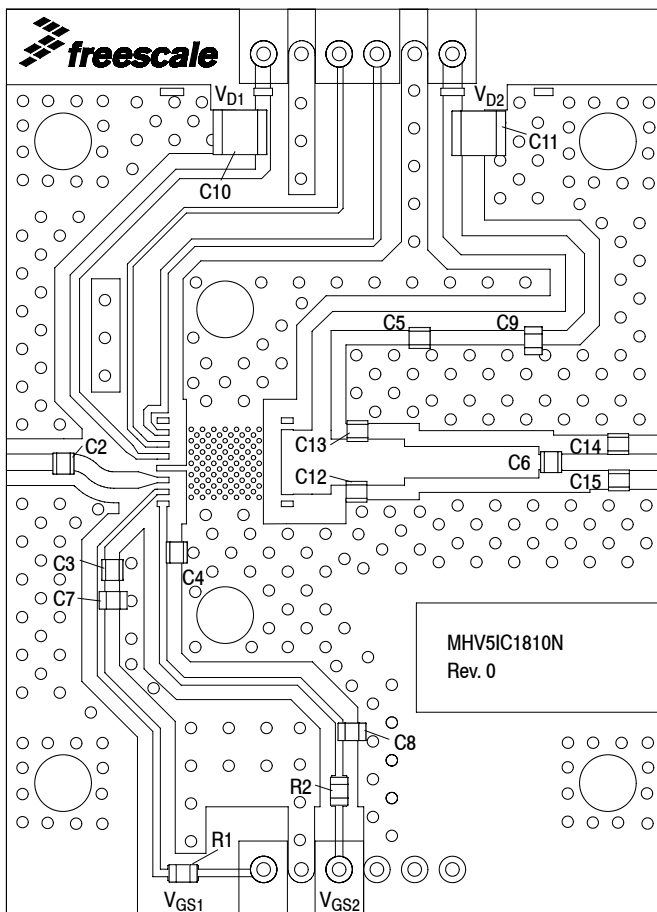
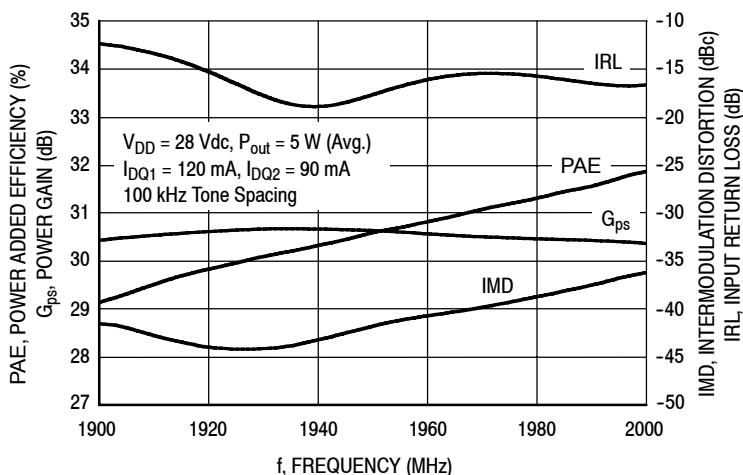
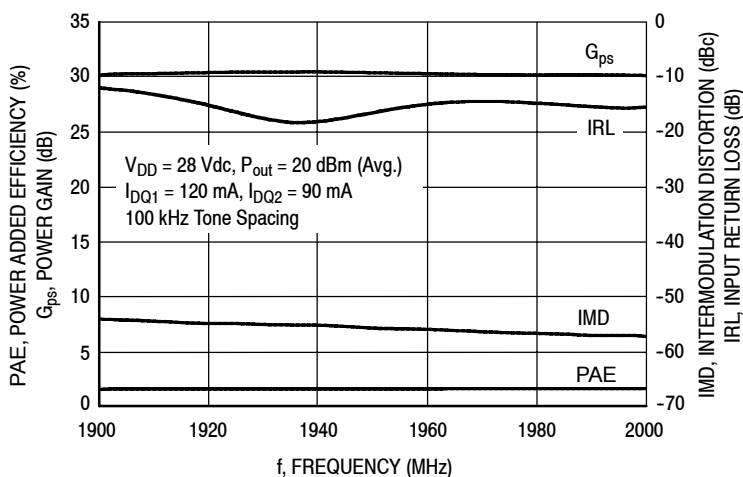


Figure 4. MHV5IC1810NR2 Test Circuit Component Layout — 1930-1990 MHz

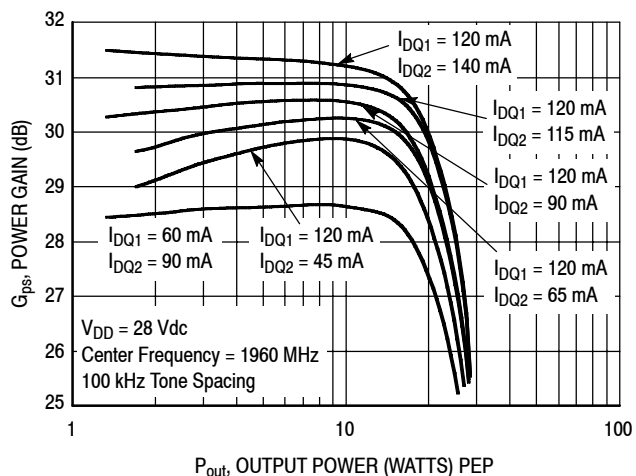
### TYPICAL CHARACTERISTICS — 1930-1990 MHz



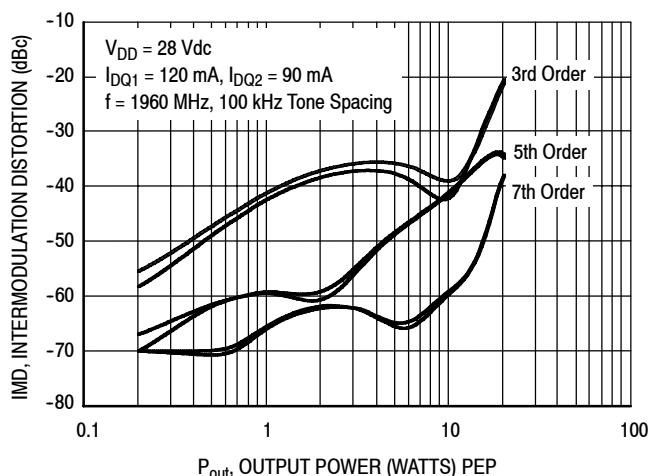
**Figure 5. Two-Tone Wideband Performance @  $P_{out} = 5$  Watts (Avg.)**



**Figure 6. Two-Tone Wideband Performance @  $P_{out} = 20$  dBm (Avg.)**



**Figure 7. Two-Tone Power Gain versus Output Power**

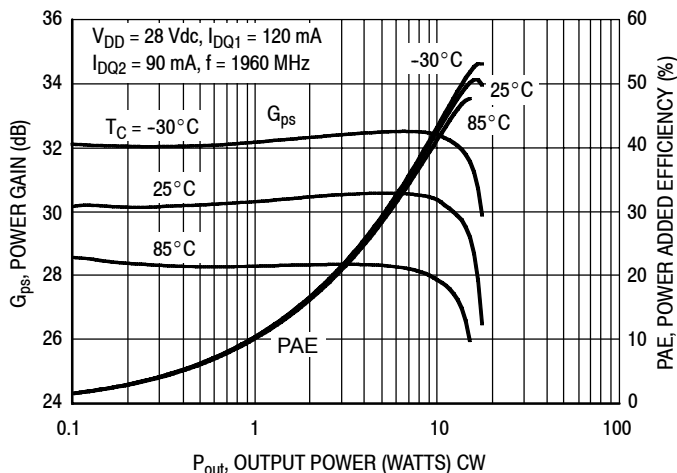


**Figure 8. Intermodulation Distortion Products versus Output Power**

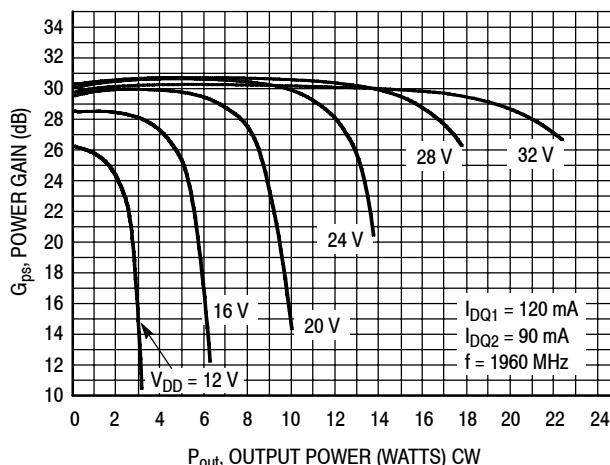
### TYPICAL CHARACTERISTICS — 1930-1990 MHz



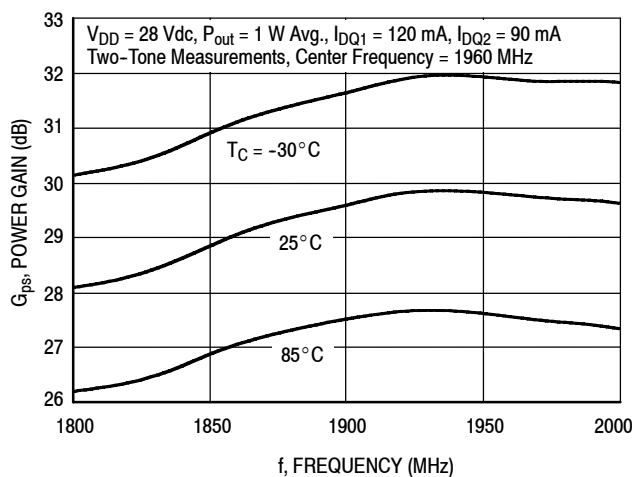
**Figure 9. Pulse CW Output Power versus Input Power**



**Figure 10. Power Gain and Power Added Efficiency versus CW Output Power**

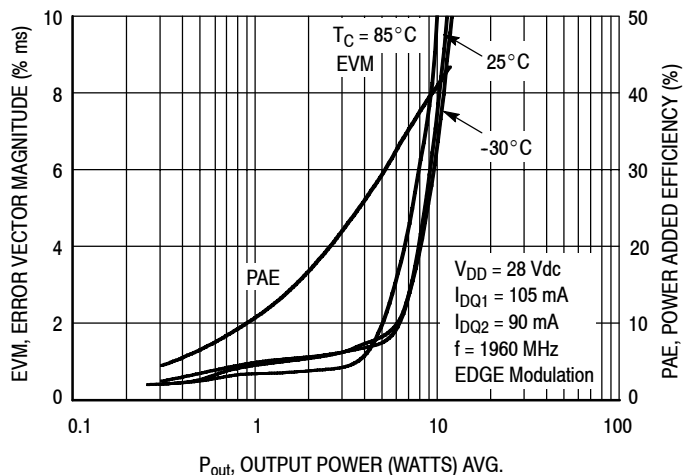


**Figure 11. Power Gain versus Output Power**

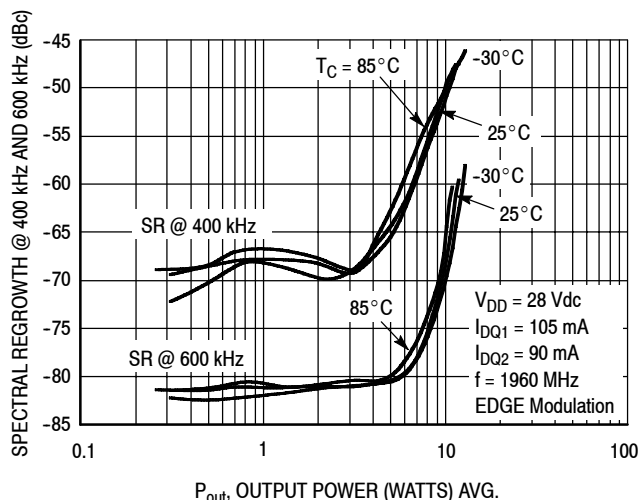


**Figure 12. Power Gain versus Frequency**

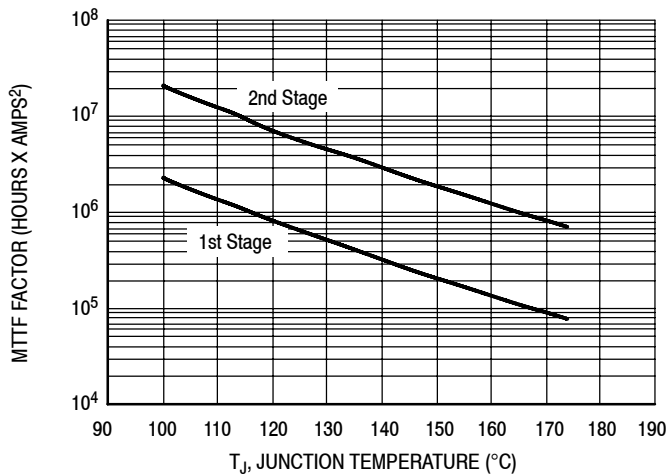
## TYPICAL CHARACTERISTICS — 1930-1990 MHz



**Figure 13. EVM and Power Added Efficiency versus Output Power**



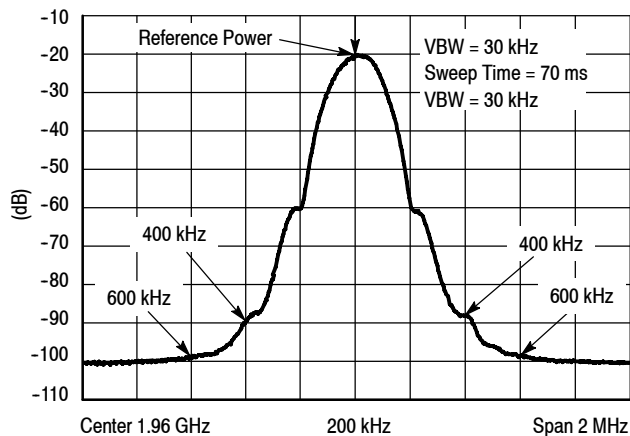
**Figure 14. Spectral Regrowth at 400 and 600 kHz versus Output Power**



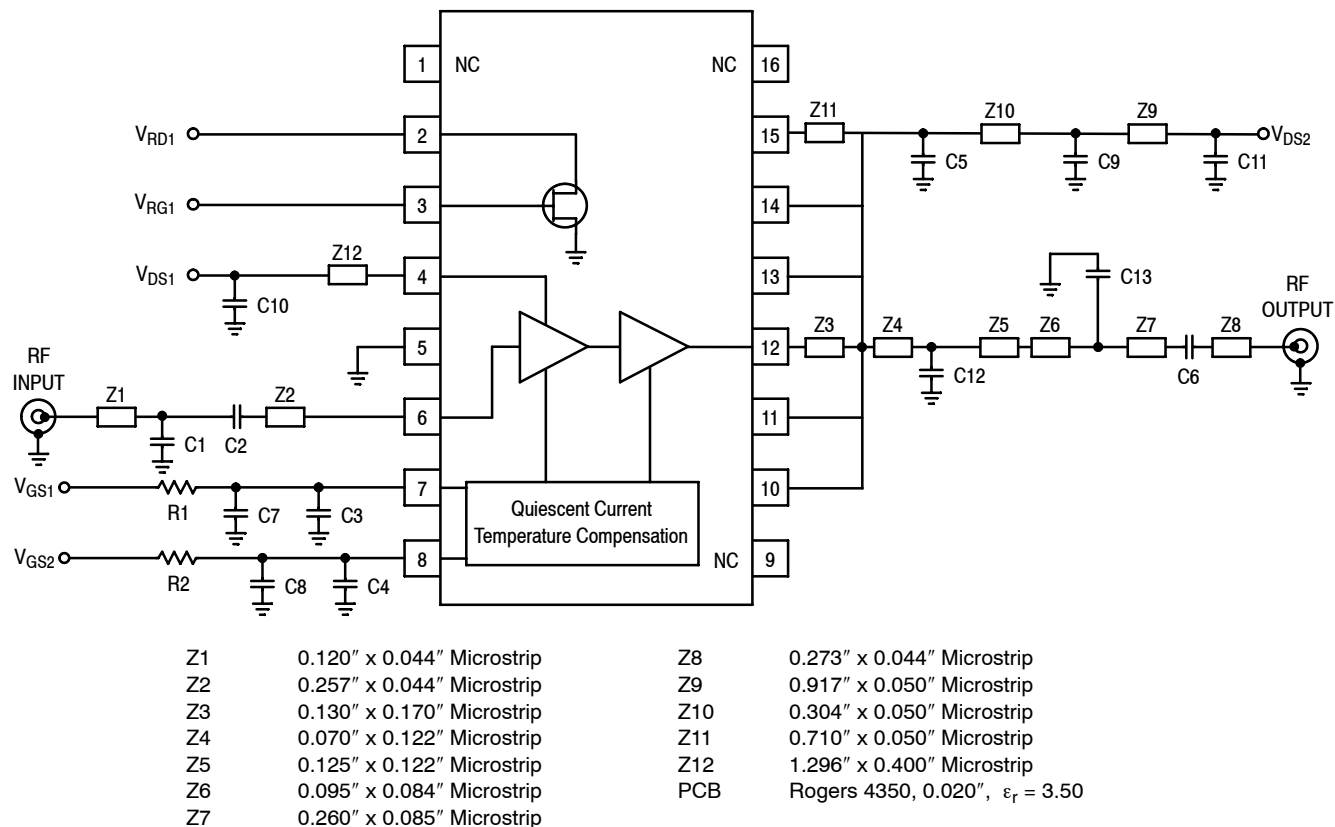
This above graph displays calculated MTTF in hours x ampere<sup>2</sup> drain current. Life tests at elevated temperatures have correlated to better than  $\pm 10\%$  of the theoretical prediction for metal failure. Divide MTTF factor by  $I_D^2$  for MTTF in a particular application.

**Figure 15. MTTF Factor versus Junction Temperature**

### GSM TEST SIGNAL



**Figure 16. EDGE Spectrum**



**Figure 17. MHV5IC1810NR2 Test Circuit Schematic — 1805-1880 MHz**

**Table 7. MHV5IC1810NR2 Test Circuit Component Designations and Values — 1805-1880 MHz**

Part	Description	Part Number	Manufacturer
C1	0.8 pF Chip Capacitor	ATC100A0R8BT500XT	ATC
C2	27 pF Chip Capacitor	ATC100A270GT500XT	ATC
C3, C4, C5, C6	8.2 pF Chip Capacitors	ATC100A8R2CT500XT	ATC
C7, C8, C9	10 nF Chip Capacitors	08055C103KAT	AVX
C10, C11	6.8 $\mu$ F Chip Capacitors	C4532X5R1H685MT	TDK
C12, C13	3.3 pF Chip Capacitors	ATC100A3R3BT500XT	ATC
R1, R2	1 k $\Omega$ , 1/8 W Chip Resistors	CRCW1K00FKEA	Vishay

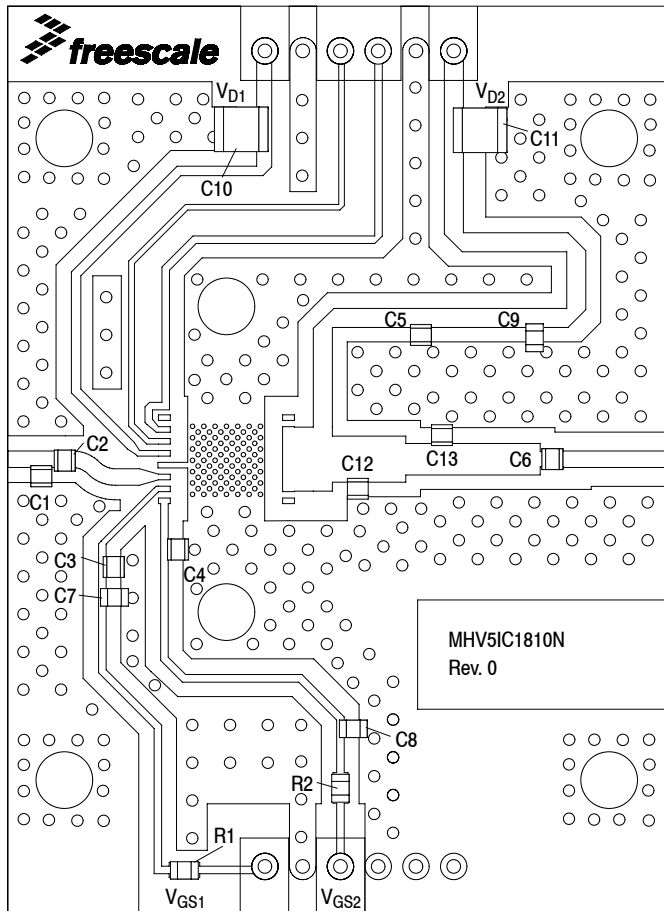


Figure 18. MHV5IC1810NR2 Test Circuit Component Layout — 1805-1880 MHz

TYPICAL CHARACTERISTICS — 1805-1880 MHz

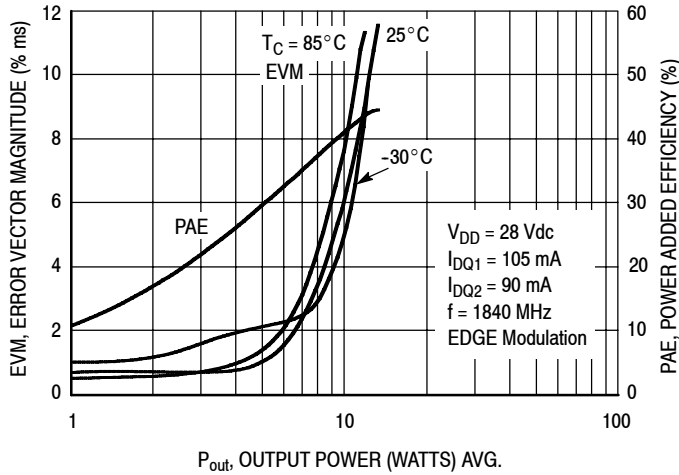


Figure 19. Spectral Regrowth at 400 and 600 kHz versus Output Power

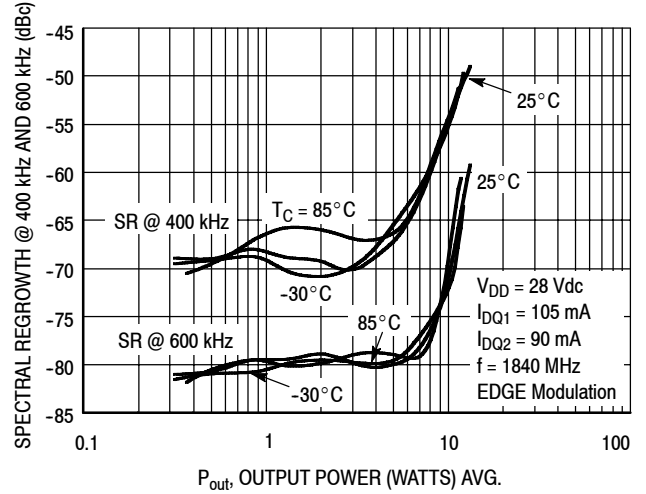
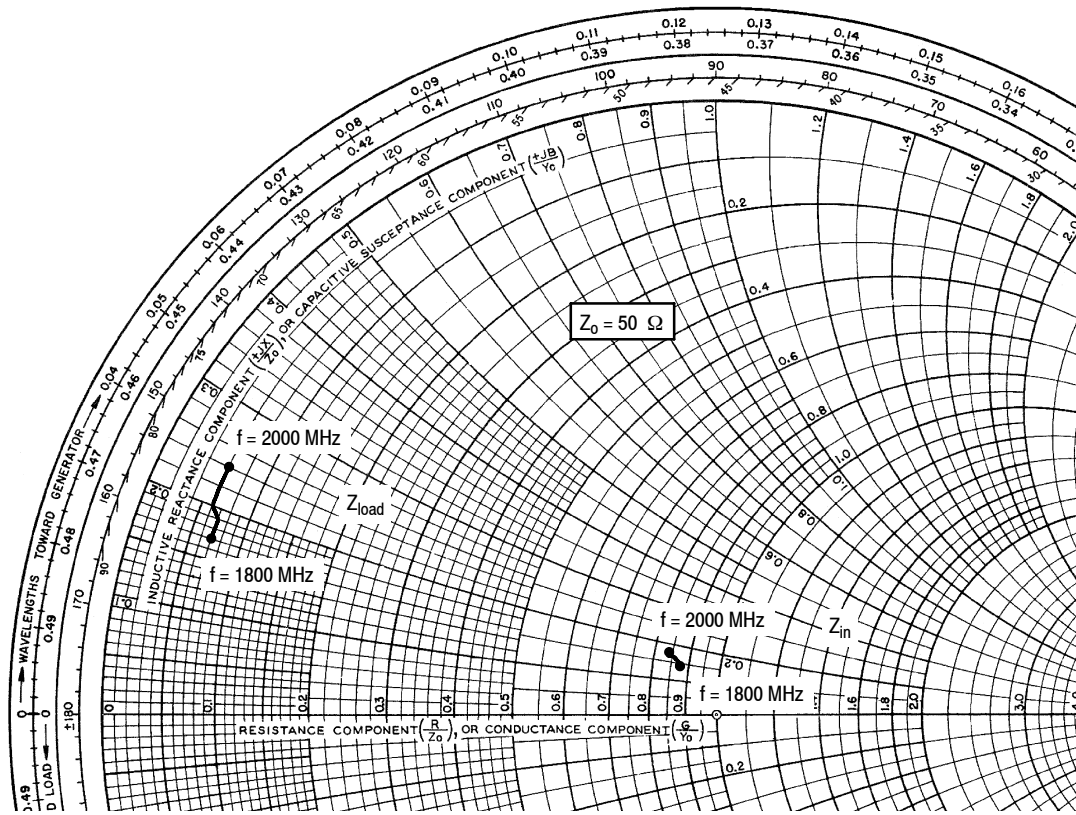


Figure 20. Spectral Regrowth at 400 and 600 kHz versus Output Power



$V_{DD} = 28 \text{ Vdc}$ ,  $I_{DQ1} = 120 \text{ mA}$ ,  $I_{DQ2} = 90 \text{ mA}$ ,  $P_{out} = 5 \text{ W Avg.}$

f MHz	$Z_{in}$ $\Omega$	$Z_{load}$ $\Omega$
1800	$43.82 + j6.83$	$3.49 + j8.58$
1820	$43.67 + j7.10$	$3.43 + j8.96$
1840	$43.50 + j7.34$	$3.36 + j9.33$
1860	$43.31 + j7.55$	$3.31 + j9.68$
1880	$43.13 + j7.76$	$3.24 + j10.04$
1900	$42.96 + j7.96$	$3.19 + j10.38$
1920	$42.76 + j8.15$	$3.14 + j10.72$
1940	$42.56 + j8.34$	$3.07 + j11.03$
1960	$42.36 + j8.50$	$3.04 + j11.36$
1980	$42.16 + j8.65$	$2.99 + j11.65$
2000	$41.97 + j8.79$	$2.94 + j11.94$

$Z_{in}$  = Test circuit impedance as measured from gate to ground.

$Z_{load}$  = Test circuit impedance as measured from drain to ground.

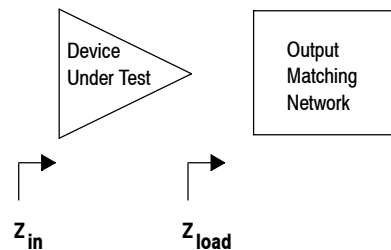
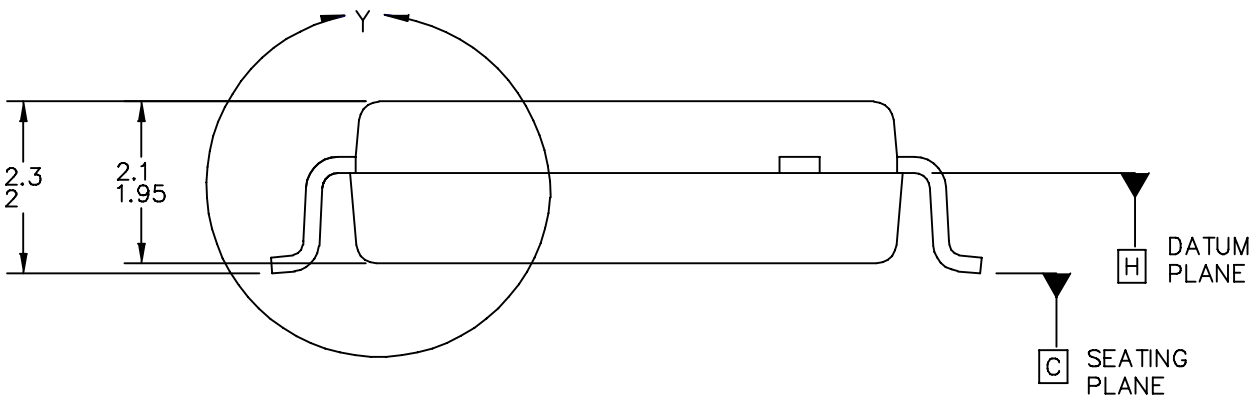
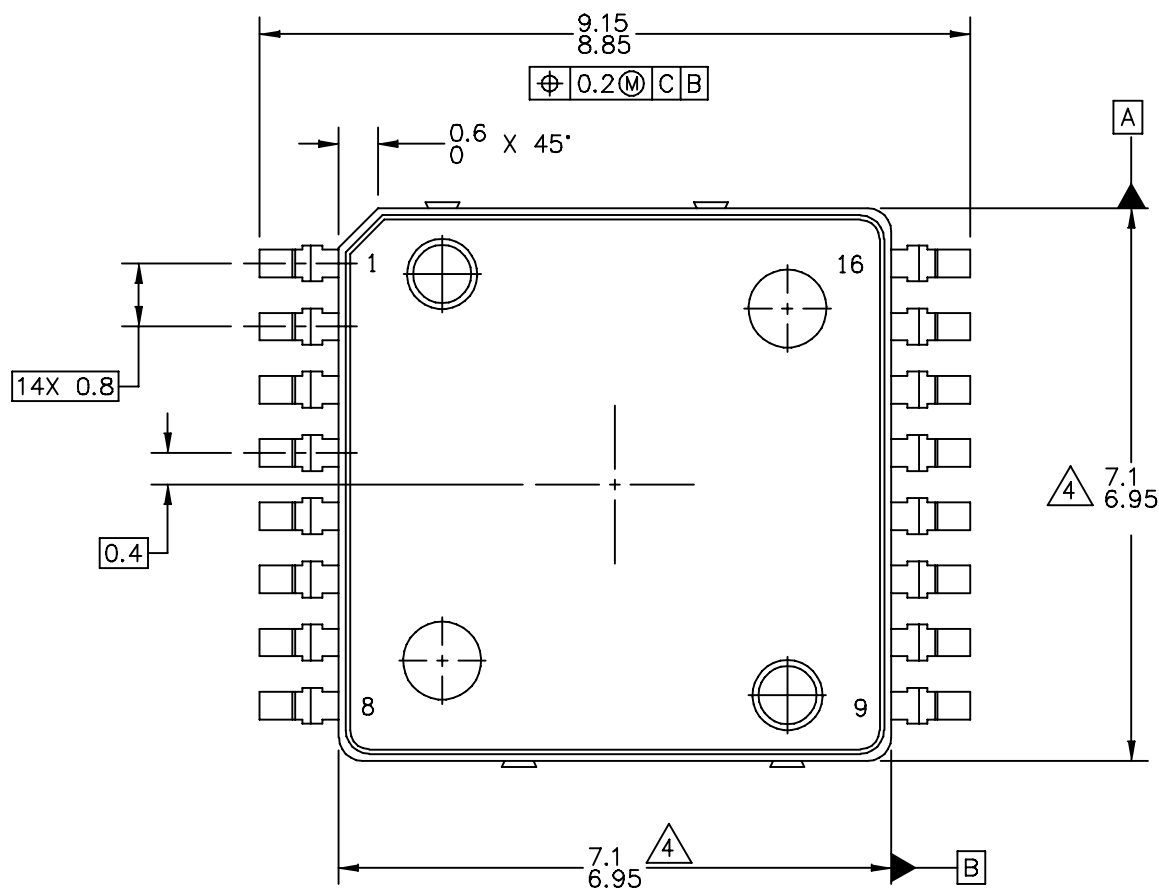
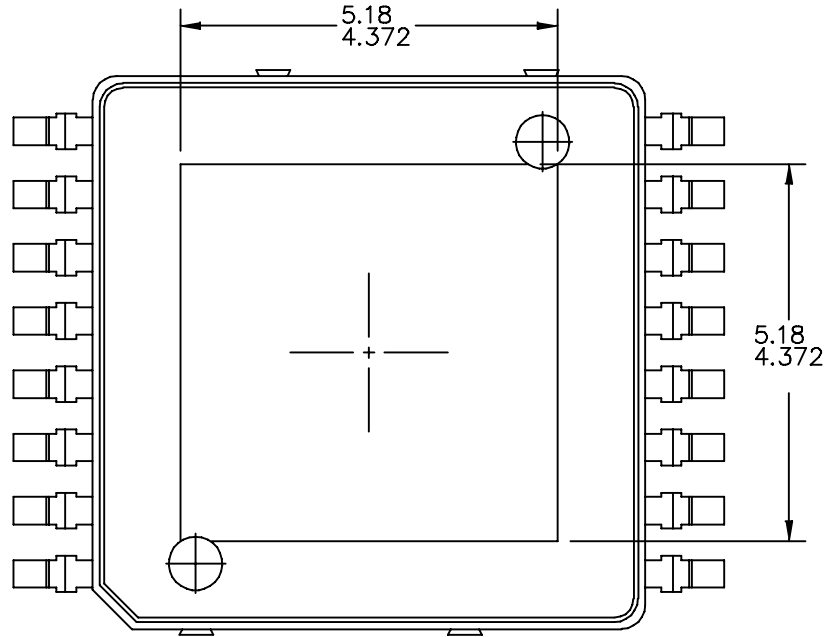


Figure 21. Series Equivalent Input and Load Impedance

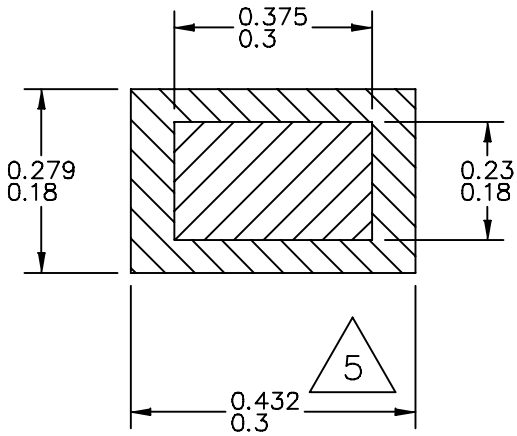
**PACKAGE DIMENSIONS**



© FREESCALE SEMICONDUCTOR, INC. ALL RIGHTS RESERVED.	MECHANICAL OUTLINE	PRINT VERSION NOT TO SCALE	
TITLE:  16 LEAD PFP	DOCUMENT NO: 98ASH70272A	REV: C	
	CASE NUMBER: 978-03	05 APR 2005	
	STANDARD: NON-JEDEC		

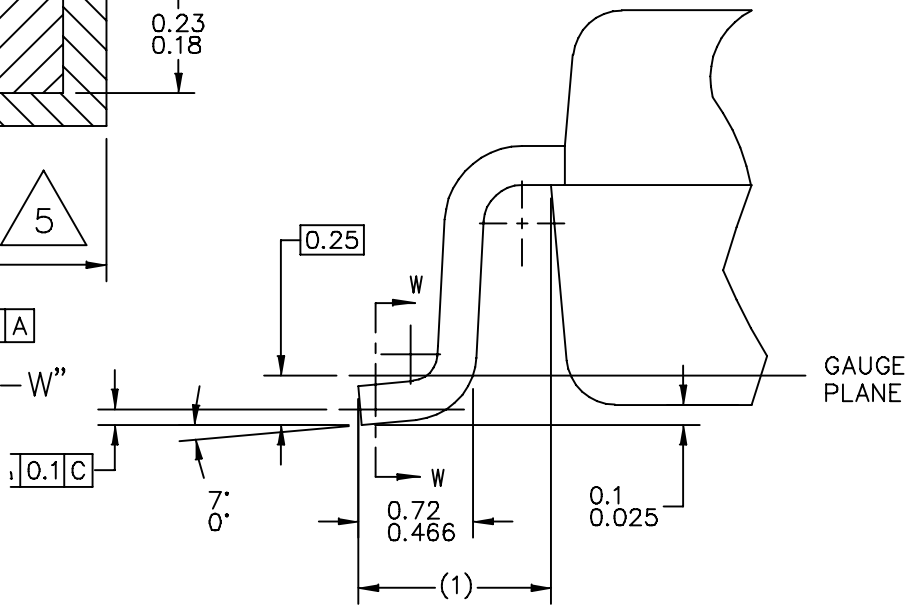


BOTTOM VIEW



$\text{M} \text{ } \text{C} \text{ } \text{A}$

SECT "W-W"



© FREESCALE SEMICONDUCTOR, INC. ALL RIGHTS RESERVED.		MECHANICAL OUTLINE		PRINT VERSION NOT TO SCALE	
TITLE:  16 LEAD PFP		DOCUMENT NO: 98ASH70272A		REV: C	
		CASE NUMBER: 978-03		05 APR 2005	
		STANDARD: NON-JEDEC			

NOTES:

1. CONTROLLING DIMENSION: MILLIMETER
2. DIMENSIONS AND TOLERANCES PER ASME Y14.5M-1994.
3. DATUM PLANE -H- IS LOCATED AT BOTTOM OF LEAD AND IS COINCIDENT WITH THE LEAD WHERE THE LEAD EXITS THE PLASTIC BODY AT THE BOTTOM OF THE PARTING LINE.
4. THESE DIMENSIONS DO NOT INCLUDE MOLD PROTRUSION. ALLOWABLE PROTRUSION IS 0.250 PER SIDE. THESE DIMENSIONS DO INCLUDE MOLD MISMATCH AND ARE DETERMINED AT DATUM PLANE -H-.
5. THIS DIMENSION DOES NOT INCLUDE DAMBAR PROTRUSION. ALLOWABLE DAMBAR PROTRUSION SHALL BE 0.127 TOTAL IN EXCESS OF THIS DIMENSION AT MAXIMUM MATERIAL CONDITION.
6. DATUMS -A- AND -B- TO BE DETERMINED AT DATUM PLANE -H-.

© FREESCALE SEMICONDUCTOR, INC. ALL RIGHTS RESERVED.	MECHANICAL OUTLINE	PRINT VERSION NOT TO SCALE	
TITLE:  16 LEAD PFP		DOCUMENT NO: 98ASH70272A	REV: C
		CASE NUMBER: 978-03	05 APR 2005
		STANDARD: NON-JEDEC	

## PRODUCT DOCUMENTATION

Refer to the following documents, Tools and software to aid your design process.

### Application Notes

- AN1955: Thermal Measurement Methodology of RF Power Amplifiers
- AN1987: Quiescent Current Control for the RF Integrated Circuit Device Family

### Engineering Bulletins

- EB212: Using Data Sheet Impedances for RF LDMOS Devices

## REVISION HISTORY

The following table summarizes revisions to this document.

Revision	Date	Description
1	Mar. 2011	<ul style="list-style-type: none"> <li>• Figs. 3 and 17, Test Circuit Schematic, redrawn to reflect correct trace lengths and trace length measurements, p. 4, 9</li> <li>• Updated Part Numbers in Tables 6, 7, Component Designations and Values, to RoHS compliant part numbers, p. 4, 9</li> <li>• Added Product Documentation and Revision History, p. 16</li> </ul>

## **How to Reach Us:**

### **Home Page:**

[www.freescale.com](http://www.freescale.com)

### **Web Support:**

<http://www.freescale.com/support>

### **USA/Europe or Locations Not Listed:**

Freescale Semiconductor, Inc.  
Technical Information Center, EL516  
2100 East Elliot Road  
Tempe, Arizona 85284  
1-800-521-6274 or +1-480-768-2130  
[www.freescale.com/support](http://www.freescale.com/support)

### **Europe, Middle East, and Africa:**

Freescale Halbleiter Deutschland GmbH  
Technical Information Center  
Schatzbogen 7  
81829 Muenchen, Germany  
+44 1296 380 456 (English)  
+46 8 52200080 (English)  
+49 89 92103 559 (German)  
+33 1 69 35 48 48 (French)  
[www.freescale.com/support](http://www.freescale.com/support)

### **Japan:**

Freescale Semiconductor Japan Ltd.  
Headquarters  
ARCO Tower 15F  
1-8-1, Shimo-Meguro, Meguro-ku,  
Tokyo 153-0064  
Japan  
0120 191014 or +81 3 5437 9125  
[support.japan@freescale.com](mailto:support.japan@freescale.com)

### **Asia/Pacific:**

Freescale Semiconductor China Ltd.  
Exchange Building 23F  
No. 118 Jianguo Road  
Chaoyang District  
Beijing 100022  
China  
+86 10 5879 8000  
[support.asia@freescale.com](mailto:support.asia@freescale.com)

### **For Literature Requests Only:**

Freescale Semiconductor Literature Distribution Center  
1-800-441-2447 or +1-303-675-2140  
Fax: +1-303-675-2150  
[LDCForFreescaleSemiconductor@hibbertgroup.com](mailto:LDCForFreescaleSemiconductor@hibbertgroup.com)

Information in this document is provided solely to enable system and software implementers to use Freescale Semiconductor products. There are no express or implied copyright licenses granted hereunder to design or fabricate any integrated circuits or integrated circuits based on the information in this document.

Freescale Semiconductor reserves the right to make changes without further notice to any products herein. Freescale Semiconductor makes no warranty, representation or guarantee regarding the suitability of its products for any particular purpose, nor does Freescale Semiconductor assume any liability arising out of the application or use of any product or circuit, and specifically disclaims any and all liability, including without limitation consequential or incidental damages. "Typical" parameters that may be provided in Freescale Semiconductor data sheets and/or specifications can and do vary in different applications and actual performance may vary over time. All operating parameters, including "Typicals", must be validated for each customer application by customer's technical experts. Freescale Semiconductor does not convey any license under its patent rights nor the rights of others. Freescale Semiconductor products are not designed, intended, or authorized for use as components in systems intended for surgical implant into the body, or other applications intended to support or sustain life, or for any other application in which the failure of the Freescale Semiconductor product could create a situation where personal injury or death may occur. Should Buyer purchase or use Freescale Semiconductor products for any such unintended or unauthorized application, Buyer shall indemnify and hold Freescale Semiconductor and its officers, employees, subsidiaries, affiliates, and distributors harmless against all claims, costs, damages, and expenses, and reasonable attorney fees arising out of, directly or indirectly, any claim of personal injury or death associated with such unintended or unauthorized use, even if such claim alleges that Freescale Semiconductor was negligent regarding the design or manufacture of the part.

Freescale™ and the Freescale logo are trademarks of Freescale Semiconductor, Inc. All other product or service names are the property of their respective owners.

© Freescale Semiconductor, Inc. 2006, 2011. All rights reserved.

## Looking for pricing, stock, or lifecycle information?

Click below to explore more details on WIN SOURCE:

 [View MHV5IC1810NR2 on WIN SOURCE](#)

 [NXP / Nexperia Information](#)

## Optimize Your Supply Chain with WIN SOURCE Solutions

-  Global Sourcing Solution
-  Obsolete Management
-  Cost Control Management
-  Shortage Management
-  Alternative Solution
-  Excess Inventory Management