



**THE DATASHEET OF
SP336ECY-L**



GENERAL DESCRIPTION

The SP336E is a monolithic serial multi-transceiver device that contains both RS-232 and RS-485/RS-422 line drivers and receivers. The configuration of the SP336E can be reconfigured into eight operating modes including RS-232 only (4TX/4RX), RS-485/RS-422 only (2TX/2RX) full or half duplex, two RS-232/RS-485 mixed modes, two shutdown modes and a diagnostic loop-back mode. Modes may be selected at any time by changing the logic state of the three MODE pins. The device can implement a dual-mode serial port, mixed mode ports or as an interface signal translator. The MaxLinear charge pumps deliver true RS-232 driver output voltages from a single power supply at either 3.3V or 5V. The SP336E requires only four 0.1 μ F capacitors for charge pump. A slew rate control pin configures driver outputs for either high data rate or slew-controlled data rates. Slew-controlled outputs minimize problems with reflections and ringing on long or un-terminated cables. All RS-485 receivers or transceivers feature high impedance which allow up to 256 transceivers on a shared bus. When configured in RS-485/RS-422 mode, each driver may be individually enabled or put into tri-state, simplifying use on shared buses or bidirectional communication. All receivers have advanced failsafe protection to prevent oscillation when inputs are un-connected. In RS-232 mode each receiver input has a 5k ohm pull-down to ground. Differential Receivers will default to output logic 1 if inputs are floating, shorted or open but terminated. All driver outputs and receiver inputs are protected against ESD strikes up to $\pm 15,000$ volts.

FEATURES

- 3.3V or 5V Single Supply Operation
- Robust ± 15 kV ESD Protection (IEC 61000-4-2 Air Gap)
- Software Selectable Mode Selection
- Up to 4 Drivers, 4 Receivers RS-232/V.28
- Up to 2 Drivers, 2 Receivers RS-485/RS-422
 - Full or Half Duplex Configurations
 - 1/8th Unit Load, up to 256 receivers on bus
- Mixed RS-232/RS-485 modes
- Pin Programmable Slew Rate for Reduced EMI
- RS-485 Advanced Failsafe on Open, Short or Terminated Lines
- Diagnostic Loop-Back Function
- 28 Pin SOIC or TSSOP Packaging

TYPICAL APPLICATIONS

- Factory Automation Equipment
- Security Networks
- Industrial/Process Control Networks
- Point-Of-Sales Equipment
- Gaming Machines
- Serial Protocol Translators (ex. RS-232 to RS-485/RS-422)
- Embedded Industrial PC's
- Building Environmental Control Systems (ex. HVAC)
- Cable Repeaters / Port Extenders / Hubs

FIGURE 1. TYPICAL RS-232 APPLICATION CIRCUIT

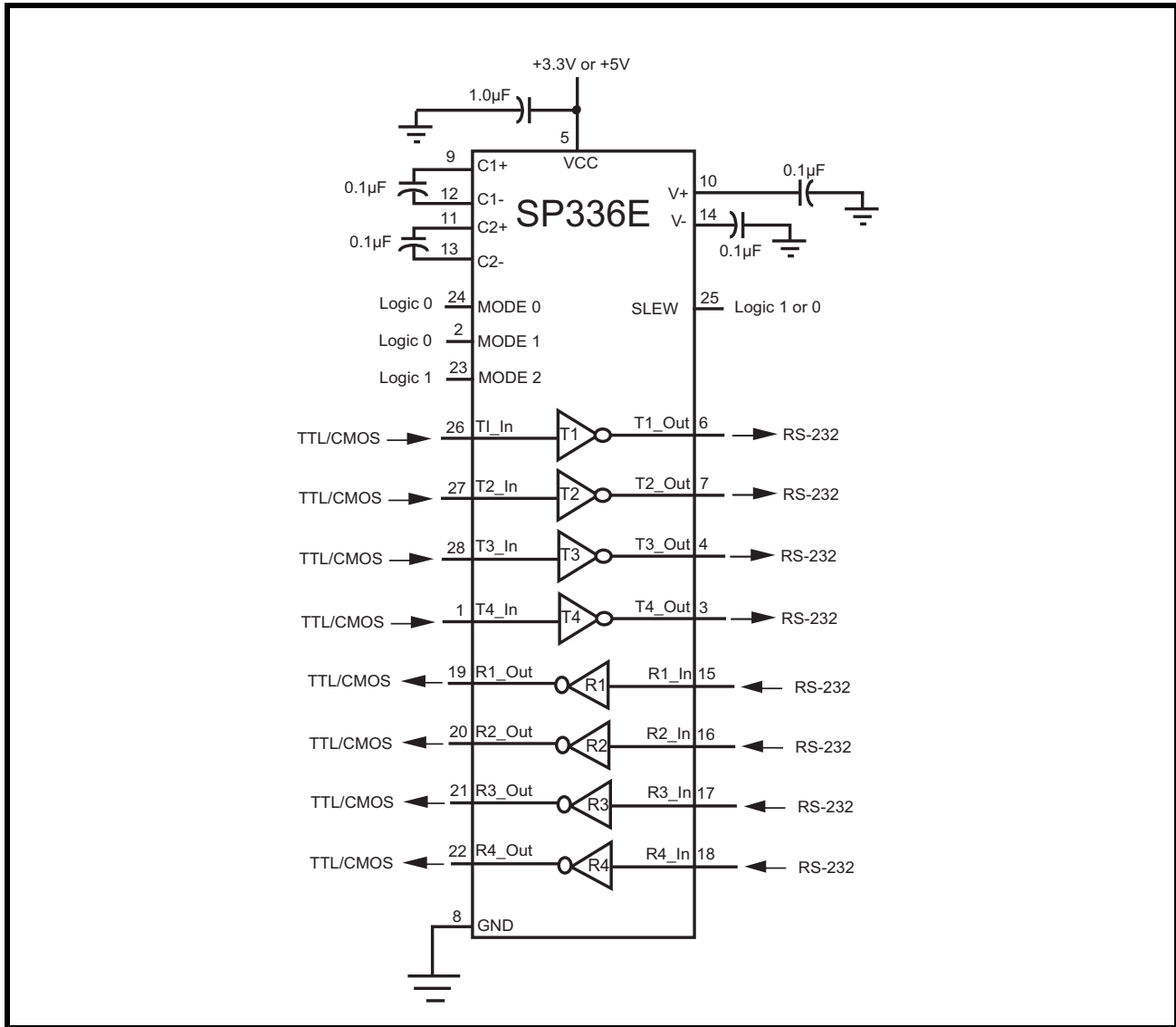
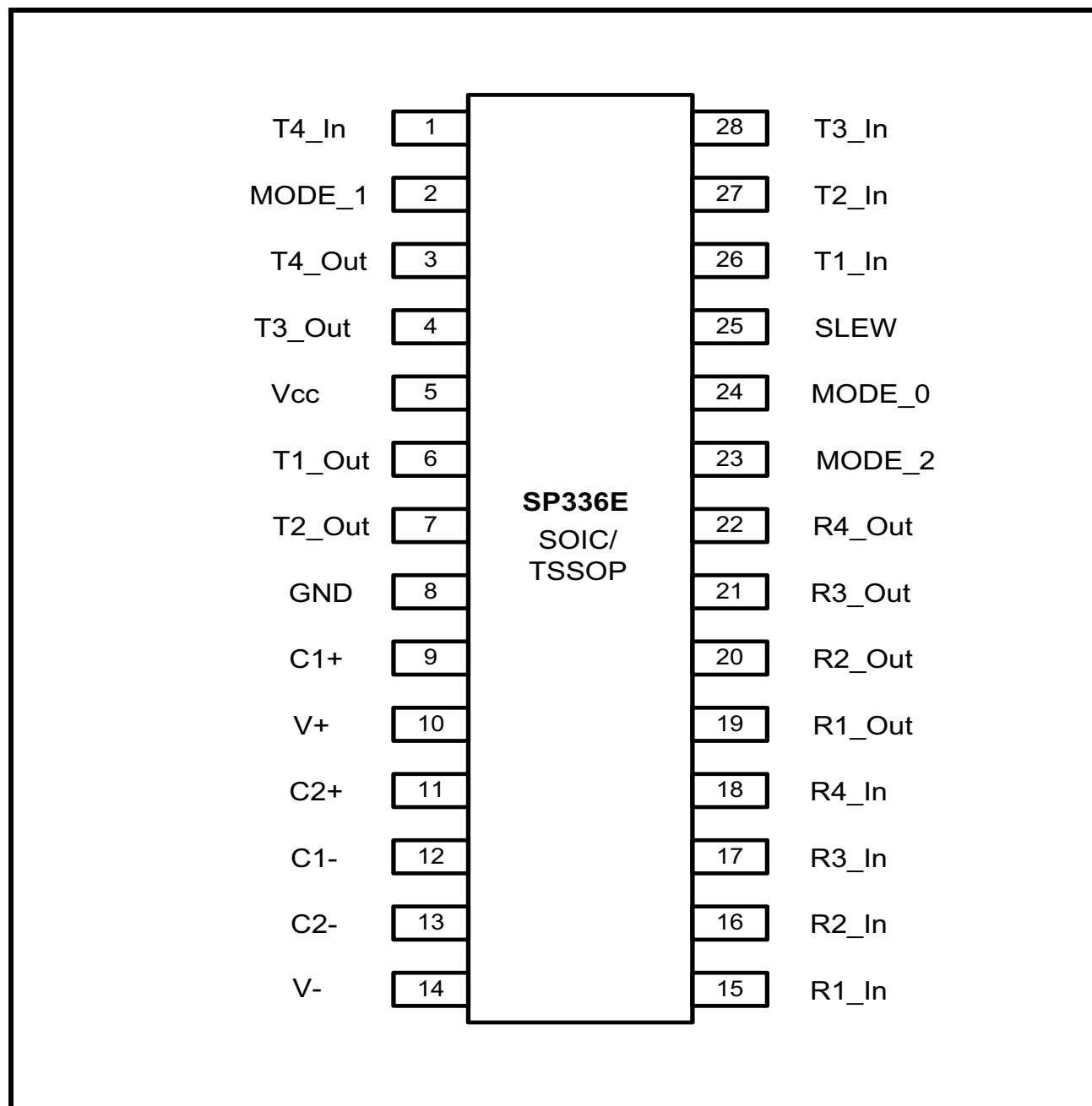

FIGURE 2. PIN OUT ASSIGNMENT

ORDERING INFORMATION⁽¹⁾

PART NUMBER	OPERATING TEMPERATURE RANGE	LEAD-FREE	PACKAGE	PACKAGING METHOD
SP336ECT-L	0°C to +70°C	Yes ⁽²⁾	28-pin SOIC-W	Tube
SP336ECY-L	0°C to +70°C		28-pin TSSOP	Tube
SP336EET-L	-40°C to +85°C		28-pin SOIC-W	Tube
SP336EEY-L	-40°C to +85°C		28-pin TSSOP	Tube
SP336EEY-L/TR				Tape and Reel

NOTES:

1. Refer to www.exar.com/SP336E for most up-to-date Ordering Information.
2. Visit www.exar.com for additional information on Environmental Rating.

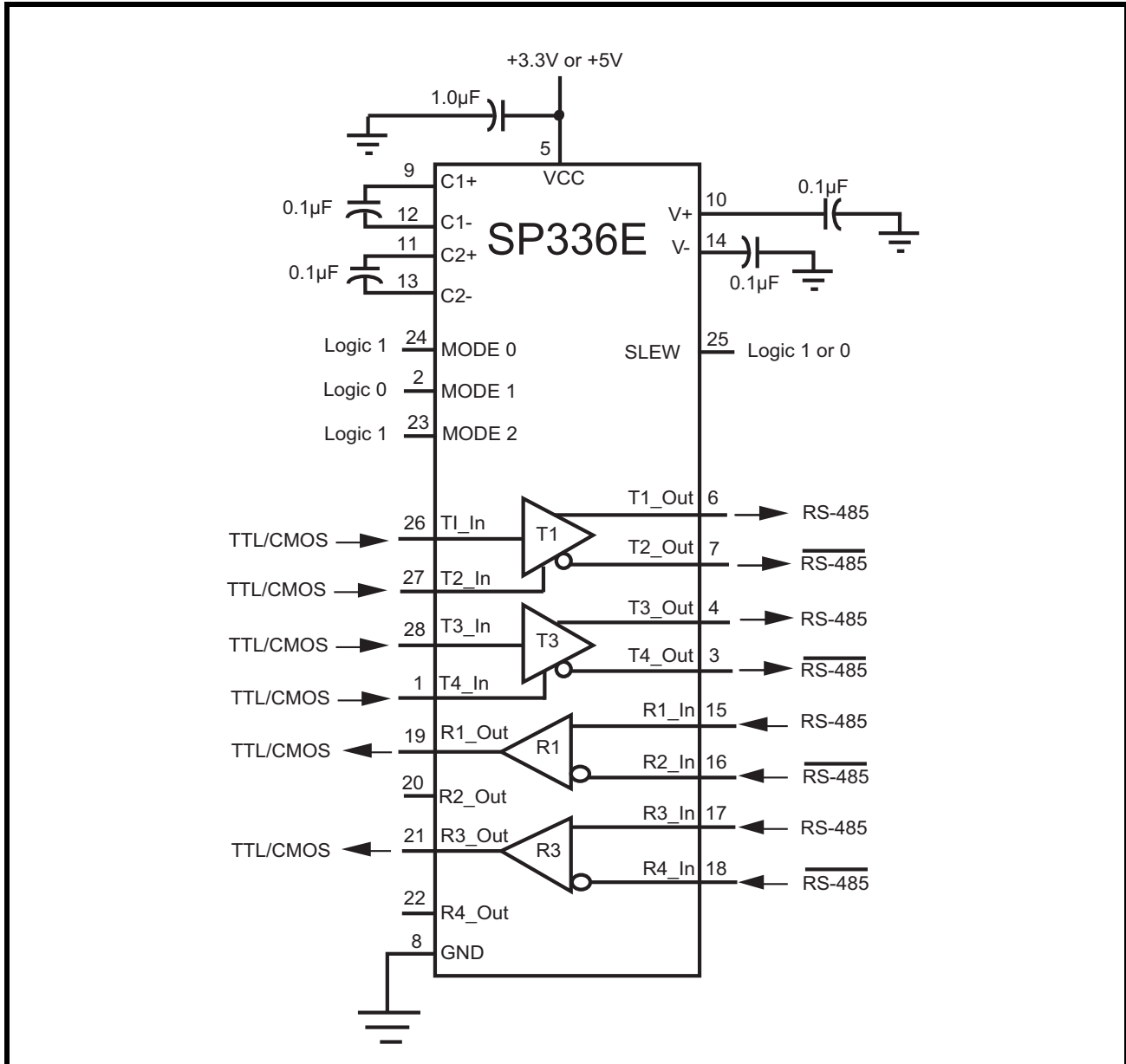
FIGURE 3. TYPICAL RS-485 APPLICATION CIRCUIT



PIN DESCRIPTIONS
Pin Assignments

PIN NUMBER	PIN NAME	TYPE	DESCRIPTION		
			SINGLE ENDED	FULL-DUPLEX	HALF-DUPLEX
1	T4_In	I	T4 Driver TTL input.	T3 Driver Enable Active High.	T3 Driver Enable Active High, R3 Enable Active Low.
2	Mode_1	I	Mode Configuration pin 1.		
3	T4_Out	O	T4 Driver Output.	T3(B) Output.	T3(B) Output, R3(B) Input.
4	T3_Out	O	T3 Driver Output.	T3(A) Output.	T3(A) Output, R3(A) Input.
5	Vcc	Pwr	Power Supply Voltage.		
6	T1_Out	O	T1 Driver Output.	T1(A) Output.	T1(A) Output, R1(A) Input.
7	T2_Out	O	T2 Driver Output.	T1(B) Output.	T1(B) Output, R1(B) Input.
8	GND	Pwr	Ground.		
9	C1+	Pmp	Positive terminal of positive flying capacitor.		
10	V+	Pmp	Vdd storage capacitor.		
11	C2+	Pmp	Positive terminal of negative flying capacitor.		
12	C1-	Pmp	Negative terminal of positive flying capacitor.		
13	C2-	Pmp	Negative terminal of negative flying capacitor.		
14	V-	Pmp	Vss storage capacitor.		
15	R1_In	I	R1 Receiver Input.	R1(A) Receiver Input.	High Impedance.
16	R2_In	I	R2 Receiver Input.	R1(B) Receiver Input.	R2 Receiver Input.
17	R3_In	I	R3 Receiver Input.	R3(A) Receiver Input.	High Impedance.
18	R4_In	I	R4 Receiver Input.	R3(B) Receiver Input.	R4 Receiver Input.
19	R1_Out	O	R1 Receiver Output.		
20	R2_Out	O	R2 Receiver Output.	High Impedance.	R2 Receiver Output.
21	R3_Out	O	R3 Receiver Output.		
22	R4_Out	O	R4 Receiver Output.	High Impedance.	R4 Receiver Output.
23	Mode_2	I	Mode Configuration pin 2.		
24	Mode_0	I	Mode Configuration pin 0.		
25	SLEW	I	Slew Rate Control. Logic Low input will limit driver slew from either RS-232 or RS-485 to 250kbps.		
26	T1_In	I	T1 Driver Input.		

Pin Assignments

PIN NUMBER	PIN NAME	TYPE	DESCRIPTION		
			SINGLE ENDED	FULL-DUPLEX	HALF-DUPLEX
27	T2_In	I	T2 Driver Input.	T1 Driver Enable Active High.	T1 Driver Enable Active High and R1 Receiver Enable Active Low.
28	T3_In	I	T3 Driver Input.		

Pin type: I=Input, O=Output, Pwr=Power supply, Pmp = Charge pump.

MODE CONFIGURATION

OPERATION:	RS-232 MODE	MIXED-PROTOCOL FULL DUPLEX
	4T/4R RS-232	2T/2R RS-232 & 1T/1R RS-485
MODE (M0, M1, M2)	001	011

MODE CONFIGURATION (CONTINUED)

OPERATION:	LOW POWER SHUTDOWN	RS-485/RS-422 FULL DUPLEX
	ALL I/O AT HIGH IMPEDANCE	2T/2R RS-485
MODE (M0, M1, M2)	111	101

MODE CONFIGURATION (CONTINUED)

OPERATION:	LOOP-BACK TXIN TO RXOUT	MIXED-PROTOCOL HALF DUPLEX
	TXOUT AND RXIN HIGH IMPEDANCE	2T/3R RS-232 & 1T/1R RS-485
MODE (M0, M1, M2)	000	010

MODE CONFIGURATION (CONTINUED)

OPERATION:	LOW POWER, 4 RX ACTIVE	RS-485/RS-422 HALF DUPLEX
	DRIVERS AT HIGH IMPEDANCE	2T/2R RS-485 & 2R RS-232
MODE (M0, M1, M2)	110	100

ABSOLUTE MAXIMUM RATINGS

These are stress ratings only and functional operation of the device at these ratings or any other above those indicated in the operation sections to the specifications below is not implied. Exposure to absolute maximum rating conditions for extended periods of time may affect reliability and cause permanent damage to the device.

Supply Voltage V_{CC}	+6.0V
Receiver Input V_{IN} (DC Input Voltage)	-15V to +15V
Input Voltage at TTL input Pins	-0.3V to $V_{CC} + 0.5V$
Driver Output Voltage (from Ground)	-7.5V to +12.5V
Short Circuit Duration, TXout to GND	Continuous
Storage Temperature Range	-65°C to + 150°C
Lead Temperature (soldering, 10s)	+300°C
Power Dissipation 28-pin SOIC-W (derate 17mW/°C above +70°C)	938mW
Power Dissipation 28-pin TSSOP (derate 12mW/°C above +70°C)	657mW
ESD Ratings	
HBM - Human Body Model (Tx_Out & Rx_In Pins)	±15kV
HBM - Human Body Model (all other pins)	± 2kV
IEC 61000-4-2 Airgap Discharge (Tx_Out & Rx_In Pins)	±15kV
IEC 61000-4-2 Contact Discharge (Tx_Out & Rx_In Pins)	± 8kV

CAUTION:

ESD (Electrostatic Discharge) sensitive device. Permanent damage may occur on unconnected devices subject to high energy electrostatic fields. Unused devices must be stored in conductive foam or shunts. Personnel should be properly grounded prior to handling this device. The protective foam should be discharged to the destination socket before devices are removed.

ELECTRICAL CHARACTERISTICS

UNLESS OTHERWISE NOTED: $V_{CC} = +3.3V \pm 5\%$ OR $+5.0V \pm 5\%$; $T_A = T_{MIN}$ TO T_{MAX} . TYPICAL VALUES ARE AT $V_{CC} = 3.3V$, $T_A = +25^\circ C$.

SYMBOL	PARAMETERS	MIN.	TYP.	MAX.	UNITS	CONDITIONS
DC CHARACTERISTICS						
I_{CC}	Supply Current (RS-232)		2	30	mA	No Load, MODE = 001.
I_{CC}	Supply Current (RS-485)		6.5	20	mA	No Load, MODE = 101.
I_{CC}	V_{CC} Shutdown Current		1	20	μA	MODE = 111.
TRANSMITTER and LOGIC INPUT PINS: Pins 1, 2, 23, 24, 25, 26, 27, 28						
V_{IH}	Logic Input Voltage HIGH	2.0			V	$V_{CC} = 3.3V$.
V_{IH}	Logic Input Voltage HIGH	2.4			V	$V_{CC} = 5.0V$.
V_{IL}	Logic Input Voltage LOW			0.8	V	
I_{IL}	Logic Input Pull-up Current			±15	μA	
V_{HYS}	Logic Input Hysteresis		0.5		V	

UNLESS OTHERWISE NOTED: $V_{CC} = +3.3V \pm 5\%$ OR $+5.0V \pm 5\%$; $T_A = T_{MIN}$ TO T_{MAX} . TYPICAL VALUES ARE AT $V_{CC} = 3.3V$, $T_A = +25^{\circ}C$.

SYMBOL	PARAMETERS	MIN.	TYP.	MAX.	UNITS	CONDITIONS
RS-232 and RS-485/422 RECEIVER OUTPUTS: Pins 19, 20, 21, 22						
V_{OH}	Receiver Output Voltage HIGH	$V_{CC} - 0.6$			V	$I_{OUT} = -1.5mA$.
V_{OL}	Receiver Output Voltage LOW			0.4	V	$I_{OUT} = 2.5mA$.
I_{OSS}	Receiver Output Short-Circuit Current		± 20	± 60	mA	$0 < V_o < V_{CC}$.
I_{OZ}	Receiver Output Leakage Current		± 0.05	± 1	μA	Receivers Disabled.
SINGLE-ENDED RECEIVER INPUTS (RS-232)						
	Input Voltage Range	-15		+15	V	
	Input Threshold Low	0.6	1.2		V	$V_{CC} = 3.3V$.
		0.8	1.5		V	$V_{CC} = 5.0V$.
	Input Threshold HIGH		1.5	2.0	V	$V_{CC} = 3.3V$.
				1.8	2.4	V
	Input Hysteresis		0.5		V	
	Input Resistance	3	5	7	$k\Omega$	
DIFFERENTIAL RECEIVER INPUTS (RS-485 / RS-422)						
R_{IN}	Receiver Input Resistance	96			$k\Omega$	$-7V \leq V_{CM} \leq +12V$.
V_{TH}	Receiver Differential Threshold Voltage	-200	-125	-50	mV	
ΔV_{TH}	Receiver Input Hysteresis		30		mV	$V_{CM} = 0V$.
I_{IN}	Input Current			125	μA	$DE = 0V$, $V_{IN} = 12V$, Full-Duplex.
				-100	μA	$DE = 0V$, $V_{IN} = -7V$, Full-Duplex.
SINGLE-ENDED DRIVER OUTPUTS (RS-232)						
V_O	Output Voltage Swing	± 5.0	± 5.4		V	Output Loaded with $3k\Omega$ to GND.
				± 6.6	V	No Load Output.
	Short Circuit Current			± 60	mA	$V_O = 0V$.
	Power Off Impedance	300	10M		Ω	$V_{CC} = 0V$; $V_O = \pm 2V$.
DIFFERENTIAL DRIVER OUTPUTS (RS-485 / RS-422)						
V_{OD}	Differential Driver Output (Tx_Out)	2		V_{CC}	V	$R_L = 100\Omega$ (RS-422), Figure 4.
		1.5		V_{CC}	V	$R_L = 54\Omega$ (RS-485), Figure 4.
		1.5		V_{CC}	V	$V_{CM} = -7V$, Figure 5.
		1.5		V_{CC}	V	$V_{CM} = +12V$, Figure 5.
ΔV_{OD}	Change In Magnitude of Differential Output Voltage	-0.2		+0.2	V	$R_L = 54\Omega$ or 100Ω , Figure 4.

UNLESS OTHERWISE NOTED: $V_{CC} = +3.3V \pm 5\%$ OR $+5.0V \pm 5\%$; $T_A = T_{MIN}$ TO T_{MAX} . TYPICAL VALUES ARE AT $V_{CC} = 3.3V$, $T_A = +25^\circ C$.

SYMBOL	PARAMETERS	MIN.	TYP.	MAX.	UNITS	CONDITIONS
V_{OC}	Driver Common Mode Output Voltage			3	V	$R_L = 54\Omega$ or 100Ω , Figure 4.
ΔV_{OC}	Change In Magnitude of Common Mode Output Voltage			0.2	V	$R_L = 54\Omega$ or 100Ω , Figure 4.
	Driver Output Short Circuit Current			± 250	mA	$V = +12V$ to $-7V$, Figure 6.
I_O	Output Leakage Current			± 100	μA	$DE = 0V$ or Shutdown, $V_O = +12V$ to $-7V$. $V_{CC} = 0V$ or $5.25V$.
TIMING CHARACTERISTICS						
RS-232 (SLEW = GND, 250kbps, ONE TRANSMITTER SWITCHING)						
	Maximum Data Rate	250			kbps	$R_L = 3k\Omega$, $C_L = 1000pF$.
t_{PHL}, t_{PLH}	Receiver Propagation Delay		100		ns	$C_L = 150pF$.
$ t_{PHL} - t_{PLH} $	Receiver Skew		50		ns	$C_L = 150pF$.
$ t_{PHL} - t_{PLH} $	Driver Skew		100		ns	
t_{THL}, t_{TLH}	Transition-Region Slew Rate from $+3.0V$ to $-3.0V$ or $-3.0V$ to $+3.0V$	6		30	V/ μs	$V_{CC} = 3.3V$, $T_A = 25^\circ C$, $R_L = 3k\Omega$ to $7k\Omega$, $C_L = 150pF$ to $1000pF$, Figures 20 and 21.
RS-232 (SLEW = Vcc, 1Mbps, ONE TRANSMITTER SWITCHING)						
	Maximum Data Rate	1			Mbps	$R_L = 3k\Omega$, $C_L = 250pF$.
t_{PHL}, t_{PLH}	Receiver Propagation Delay		100		ns	$C_L = 150pF$, Figures 22 and 23.
$ t_{PHL} - t_{PLH} $	Receiver Skew		50		ns	$C_L = 150pF$.
$ t_{PHL} - t_{PLH} $	Driver Skew		25		ns	
t_{THL}, t_{TLH}	Transition-Region Slew Rate from $+3.0V$ to $-3.0V$ or $-3.0V$ to $+3.0V$		90		V/ μs	$V_{CC} = 3.3V$, $R_L = 3k\Omega$ to $7k\Omega$, $C_L = 150pF$ to $1000pF$.
RS-485/RS-422 (SLEW = GND, 250kbps, ONE TRANSMITTER SWITCHING)						
	Maximum Data Rate			250	kbps	$R_{DIFF} = 54\Omega$, $C_L = 50pF$.
t_{DPHL}, t_{DPLH}	Differential Output Propagation Delay Time	250		1500	ns	Figures 7 and 8.
t_R, t_F	Driver Rise and Fall Time	200		1500	ns	Figures 7 and 8.
$ t_{DPHL} - t_{DPLH} $	Driver Propagation Delay Skew			200	ns	Figures 7 and 8.
t_{DZH}, t_{DZL}	Driver Output Enable Time			1500	ns	Figures 9, 10, 11 and 12.
t_{DHZ}, t_{DLZ}	Driver Output Disable Time			1500	ns	Figures 9, 10, 11 and 12.
t_{PHL}, t_{PLH}	Receiver Propagation Delay			150	ns	Figures 13 and 14.
t_{ZH}	Receiver Enable to Output High		50		ns	Figures 15 and 16.
t_{ZL}	Receiver Enable to Output Low		50		ns	Figures 15 and 17.

UNLESS OTHERWISE NOTED: $V_{CC} = +3.3V \pm 5\%$ OR $+5.0V \pm 5\%$; $T_A = T_{MIN}$ TO T_{MAX} . TYPICAL VALUES ARE AT $V_{CC} = 3.3V$, $T_A = +25^{\circ}C$.

SYMBOL	PARAMETERS	MIN.	TYP.	MAX.	UNITS	CONDITIONS
t_{HZ}	Receiver Output High to Disable		50		ns	Figures 15 and 18.
t_{LZ}	Receiver Output Low to Disable		50		ns	Figures 15 and 19.
RS-485/RS-422 (SLEW = V_{CC}, 10Mbps, ONE TRANSMITTER SWITCHING)						
	Maximum Data Rate			10	Mbps	$R_{DIFF} = 54\Omega$, $C_L = 50pF$.
t_{DPHL}, t_{DPLH}	Differential Output Propagation Delay Time		60	120	ns	Figures 7 and 8.
t_R, t_F	Driver Rise and Fall Time		10	25	ns	Figures 7 and 8.
$ t_{DPHL} - t_{DPLH} $	Driver Propagation Delay Skew			10	ns	Figures 7 and 8.
t_{DZH}, t_{DZL}	Driver Output Enable Time			900	ns	Figures 9, 10, 11 and 12.
t_{DHZ}, t_{DLZ}	Driver Output Disable Time			900	ns	Figures 9, 10, 11 and 12.
t_{PHL}, t_{PLH}	Receiver Propagation Delay			150	ns	Figures 13 and 14.
t_{ZH}	Receiver Enable to Output High		32		ns	Figures 15 and 16.
t_{ZL}	Receiver Enable to Output Low		32		ns	Figures 15 and 17.
t_{HZ}	Receiver Output High to Disable		40		ns	Figures 15 and 18.
t_{LZ}	Receiver Output Low to Disable		40		ns	Figures 15 and 19.

1.0 FUNCTION TABLES

The SP336E drivers and receivers may be configured to operate as either standard RS-485/RS-422 or RS-232 devices. RS-485/RS422 drivers have differential outputs and receivers have differential inputs. RS-232 drivers and receivers are single-ended with inverting outputs.

TABLE 1: R-485/RS-422 FULL DUPLEX: MODE 011 (T3, R3), MODE 101 (T1, T3, R1, R3)

DRIVERS				RECEIVERS	
Inputs		Outputs		Inputs	Output
Tx_EN	Tx_In	Tx(A)	Tx(B)	Rx(A) - Rx(B)	RxOut
1	1	1	0	> -50mV	1
1	0	0	1	≤ -200mV	0
0	x	High-Z		Open / Shorted	1

TABLE 2: R-485/RS-422 HALF DUPLEX: MODE 010 (T3, R3), MODE 100 (T1, T3, R1, R3)

TRANSMITTING				RECEIVING		
Inputs		Outputs		Inputs		Outputs
DE/RE	TxIn	Tx(A)	Tx(B)	DE/RE	Rx(A) - Rx(B)	RxOut
1	1	1	0	1	x	High-Z
1	0	0	1	1	x	High-Z
0	x	High-Z	High-Z	0	> -50mV	1
				0	≤ -200mV	0
				0	Open / Shorted	1

TABLE 3: RS-232 MODE 001 (ALL TX AND RX), MODES 011, 010 (T1, T2, R1, R2), MODE 110 (R1- R4)

DRIVERS		RECEIVERS	
Input	Output	Input	Output
0	≥ 5V	≥ 3V	0
1	≤ -5V	≤ -3V	1
Open	≤ -5V	Open	1

FIGURE 4. RS-485 DRIVER DC TEST CIRCUIT

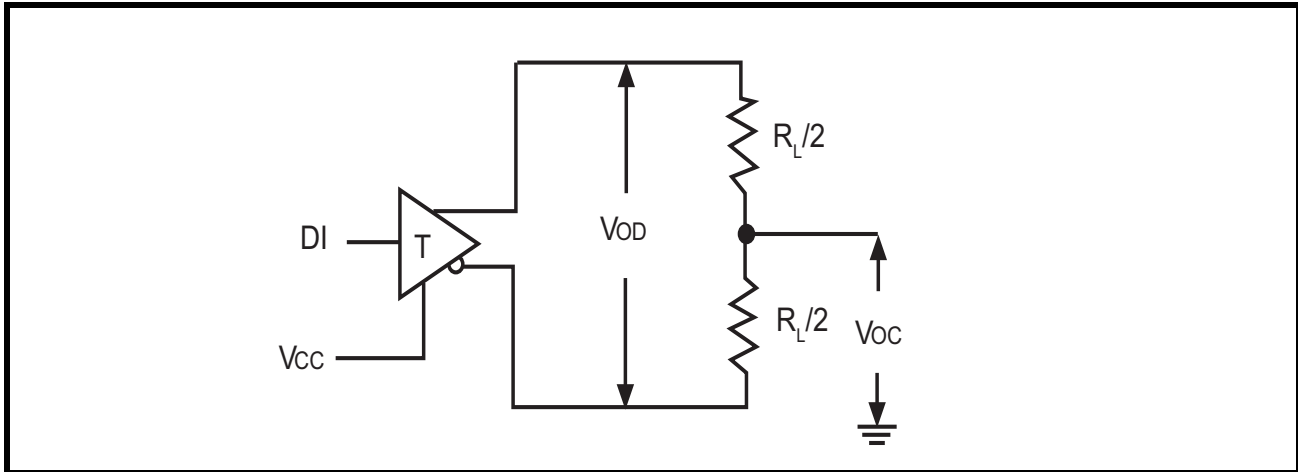

FIGURE 5. RS-485 DRIVER COMMON MODE LOAD TEST

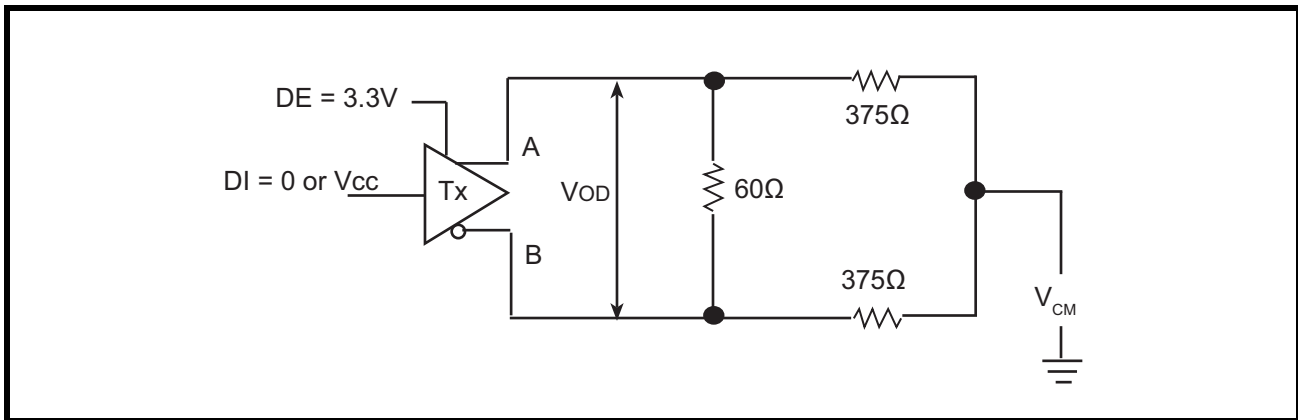

FIGURE 6. RS-485 DRIVER OUTPUT SHORT CIRCUIT TEST

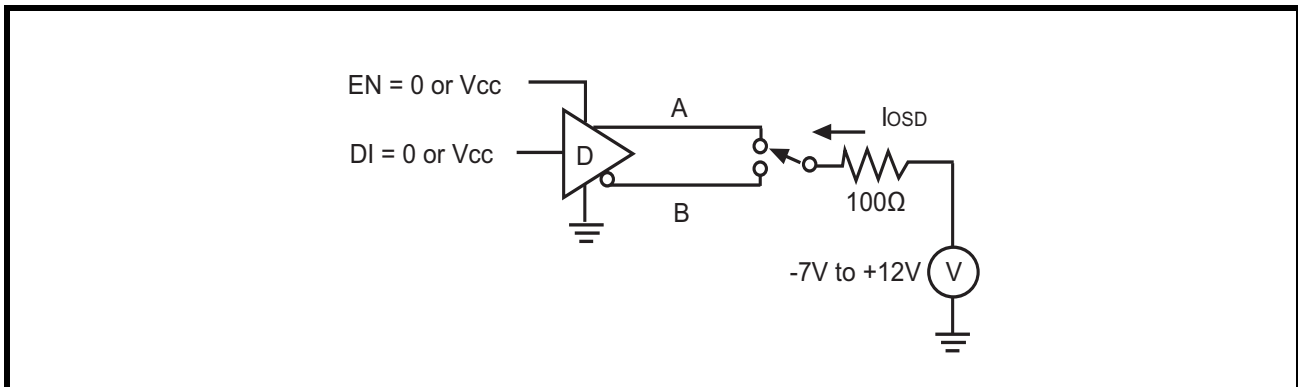

FIGURE 7. RS-485 DRIVER PROPAGATION DELAY TEST CIRCUIT

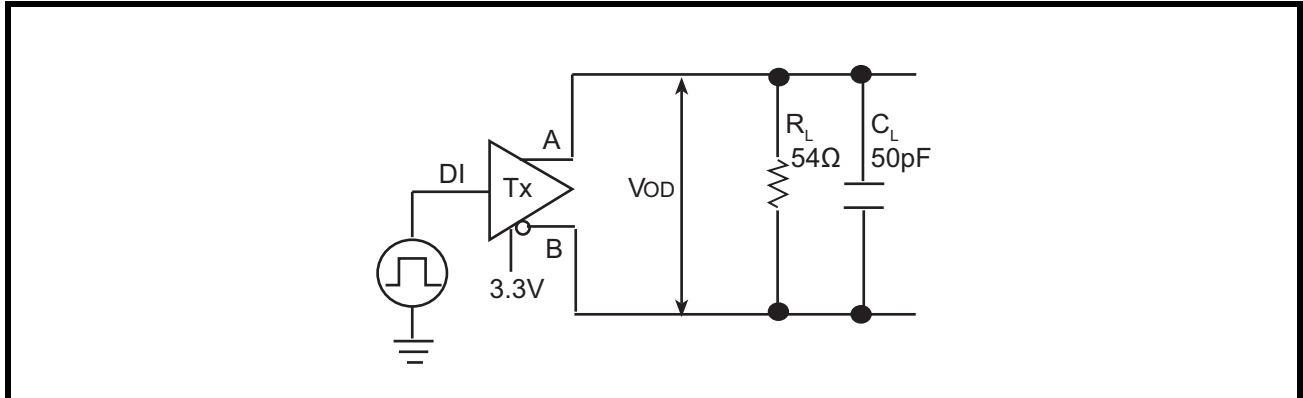

FIGURE 8. RS-485 DRIVER TIMING DIAGRAM

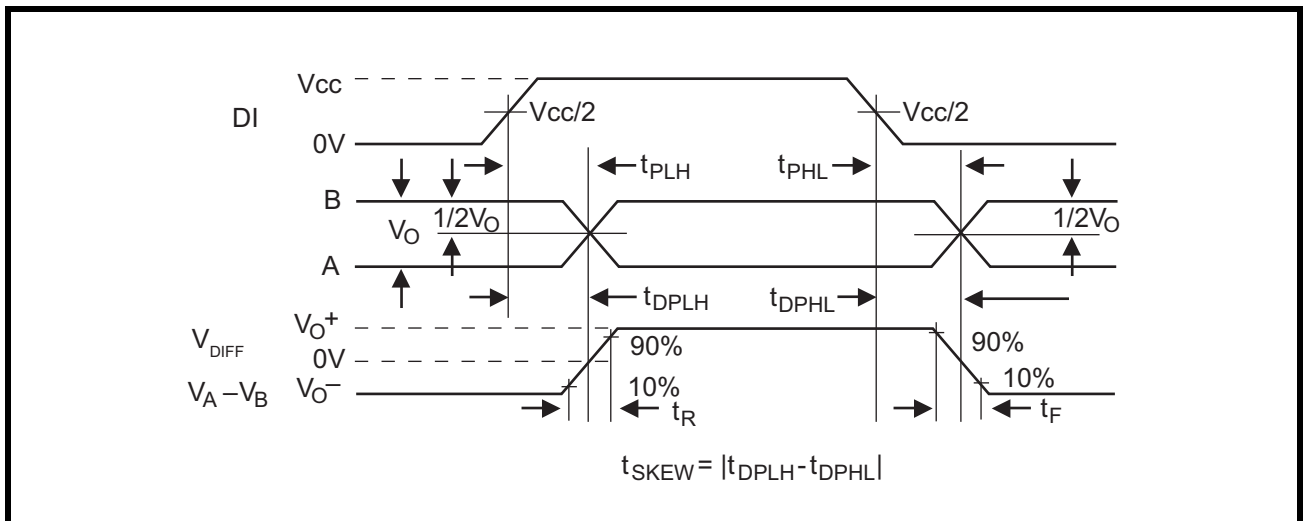

FIGURE 9. RS-485 DRIVER ENABLE AND DISABLE TEST CIRCUIT

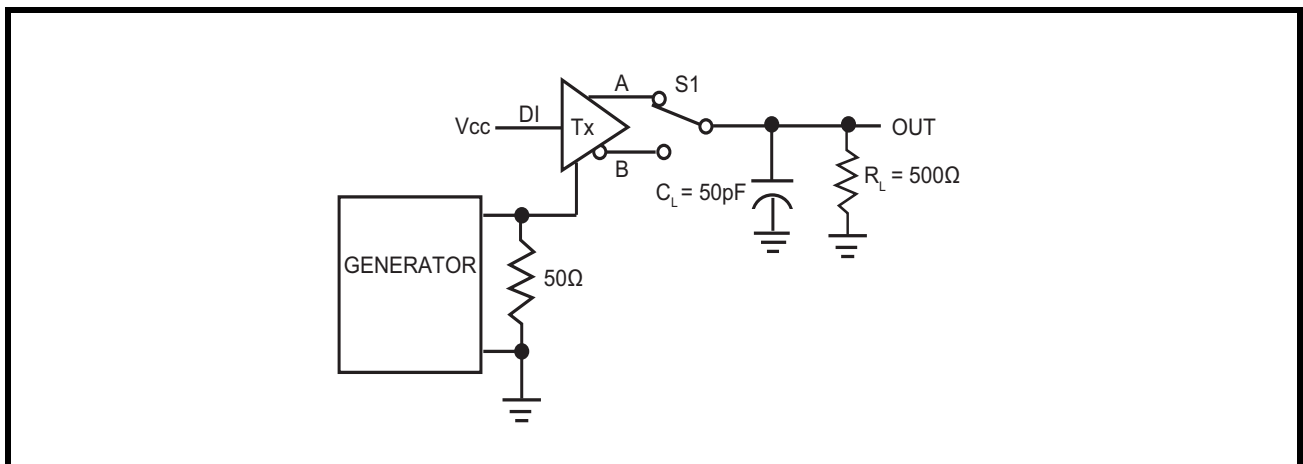

FIGURE 10. RS-485 DRIVER ENABLE AND DISABLE TIMING DIAGRAM

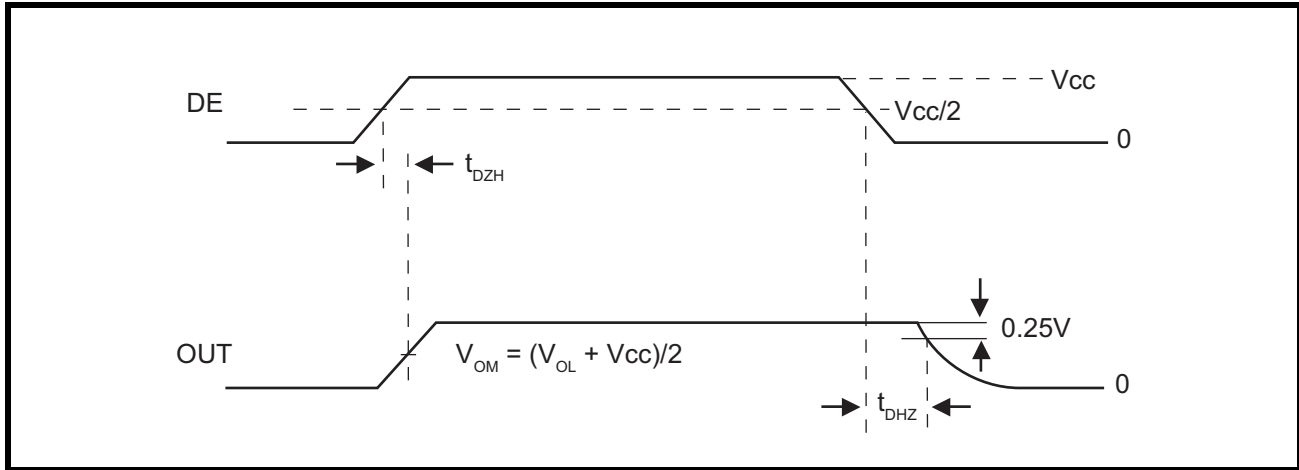

FIGURE 11. RS-485 DRIVER ENABLE AND DISABLE TEST CIRCUIT 2

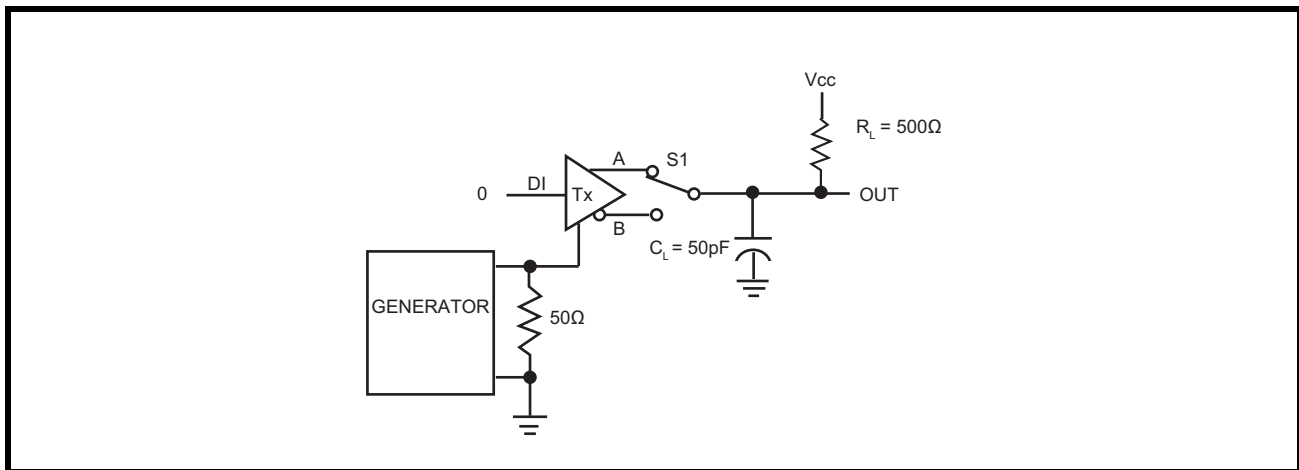

FIGURE 12. RS-485 DRIVER ENABLE AND DISABLE TIMING DIAGRAM 2

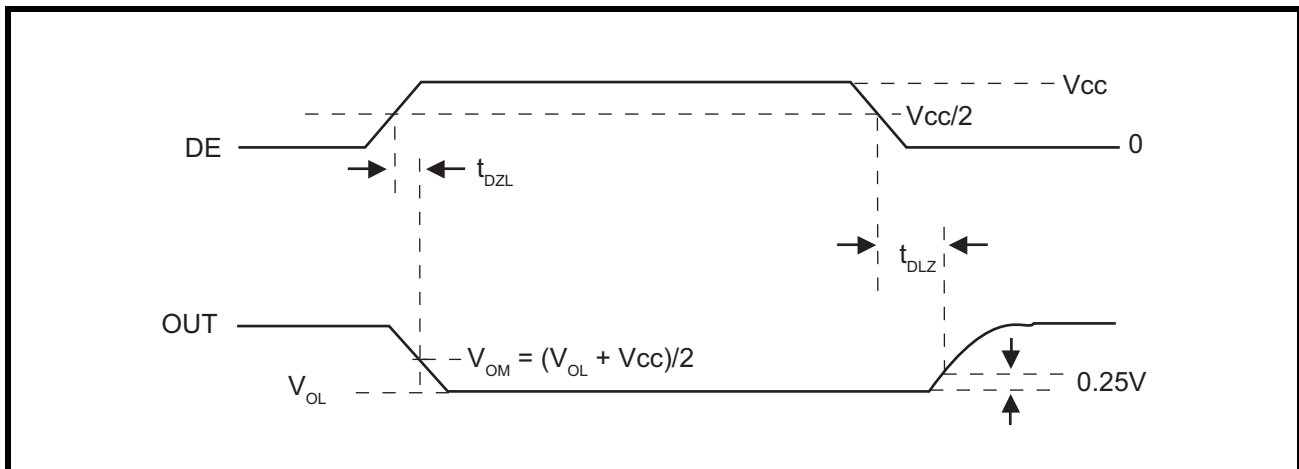

FIGURE 13. RS-485 RECEIVER PROPAGATION DELAY TEST CIRCUIT

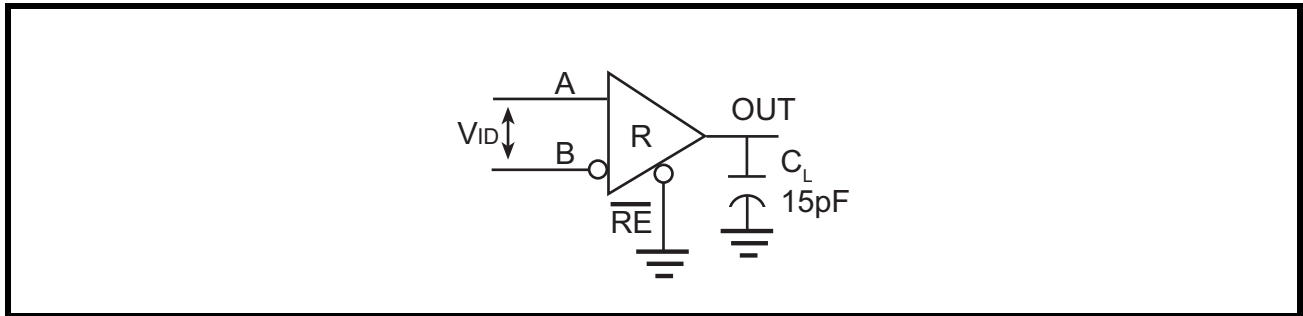

FIGURE 14. RS-485 RECEIVER PROPAGATION DELAY TIMING DIAGRAM

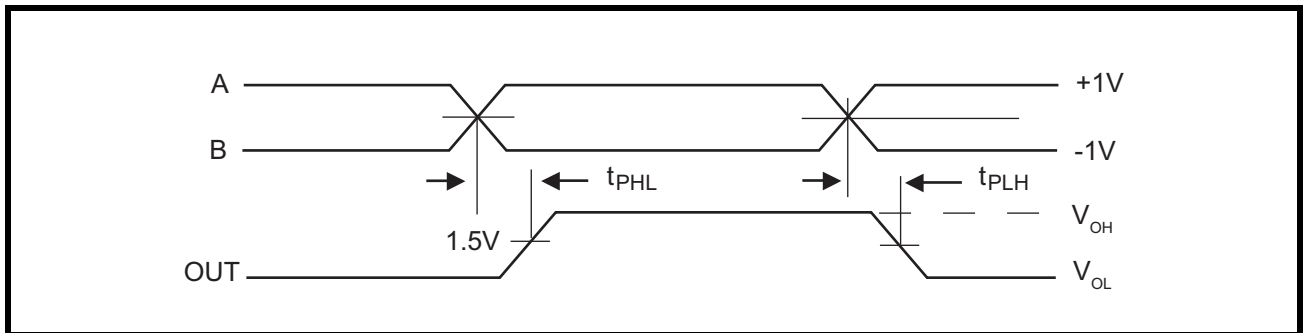

FIGURE 15. RS-485 RECEIVER ENABLE AND DISABLE TIMES TEST CIRCUIT

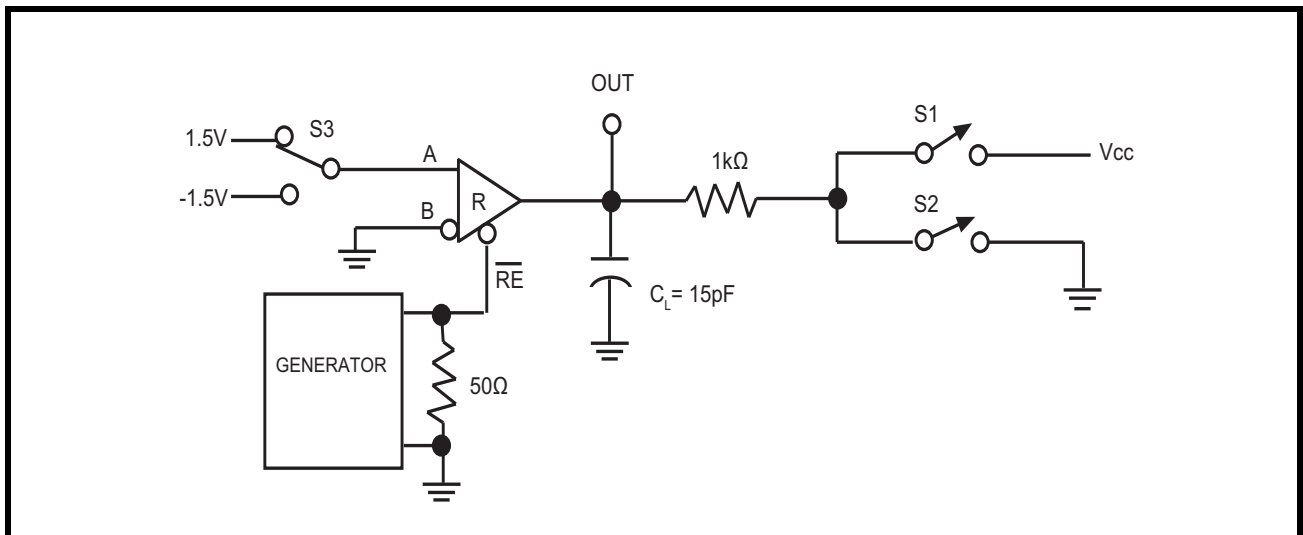

FIGURE 16. RS-485 RECEIVER ENABLE AND DISABLE TIMES TIMING DIAGRAM 1

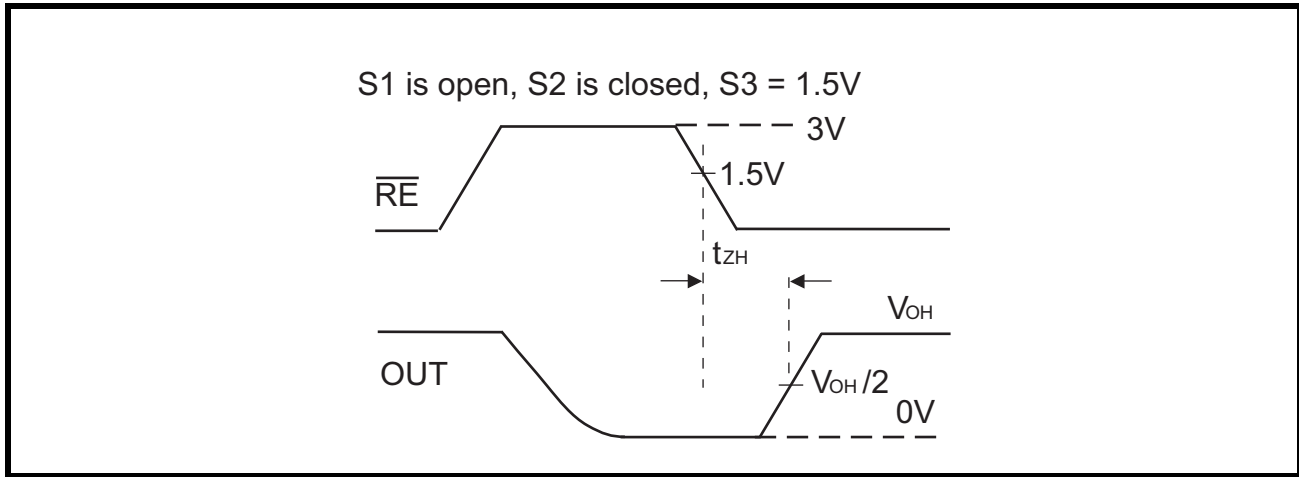

FIGURE 17. RS-485 RECEIVER ENABLE AND DISABLE TIMES TIMING DIAGRAM 2

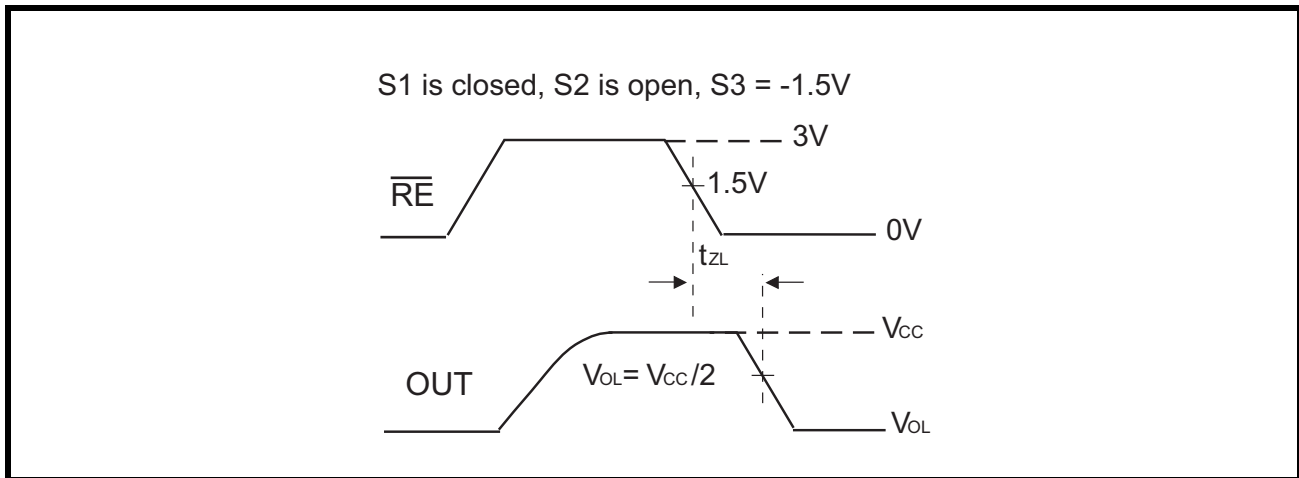

FIGURE 18. RS-485 RECEIVER ENABLE AND DISABLE TIMES TIMING DIAGRAM 3

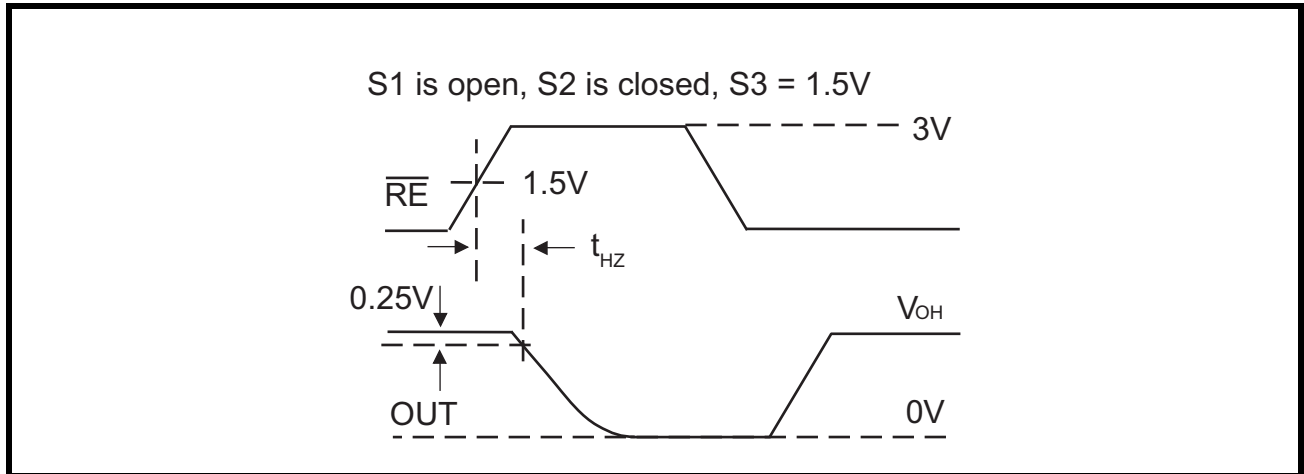

FIGURE 19. RS-485 RECEIVER ENABLE AND DISABLE TIMES TIMING DIAGRAM 4

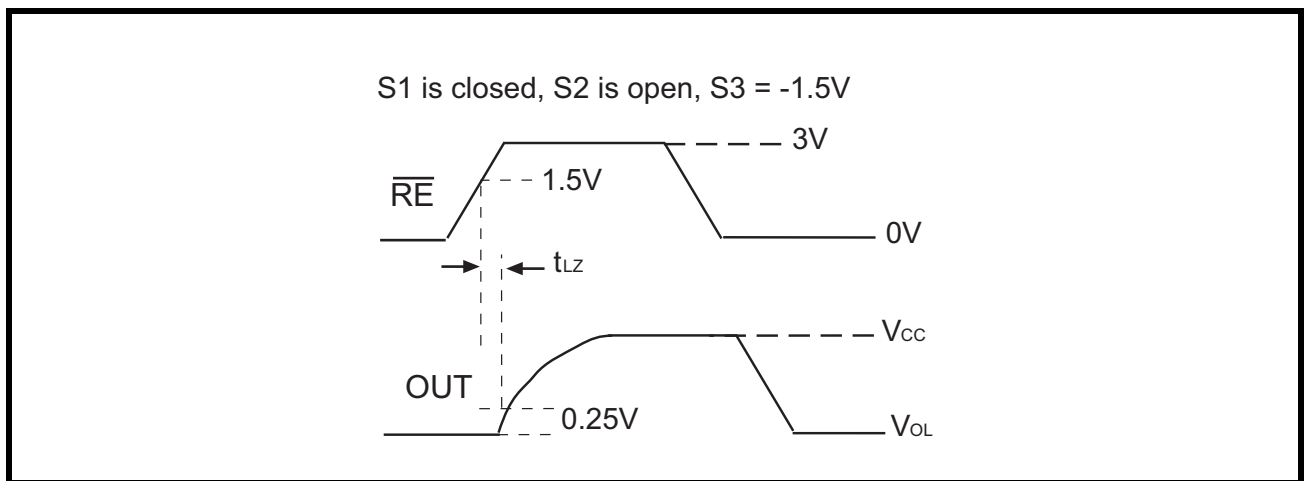

FIGURE 20. RS-232 DRIVER OUTPUT SLEW RATE TEST CIRCUIT

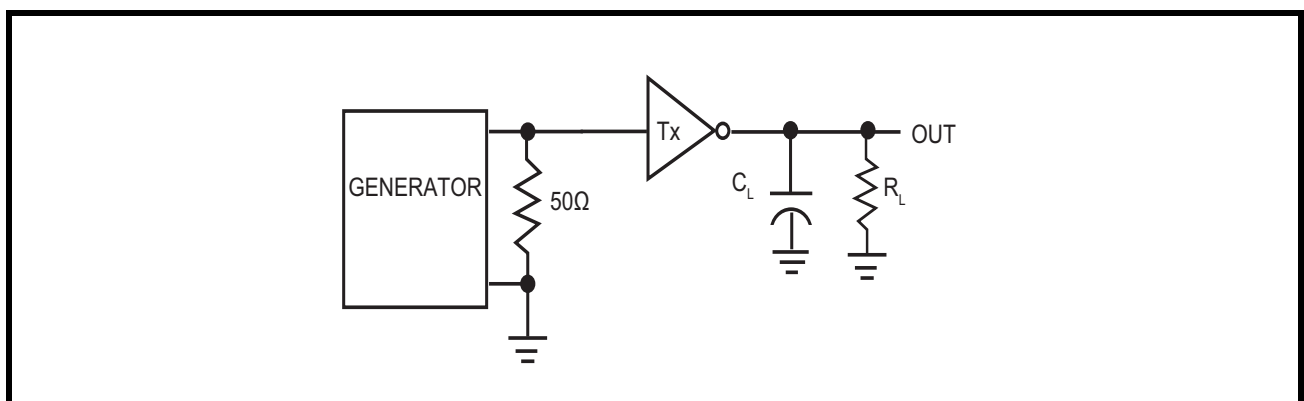

FIGURE 21. RS-232 DRIVER OUTPUT SLEW RATE TIMING DIAGRAM

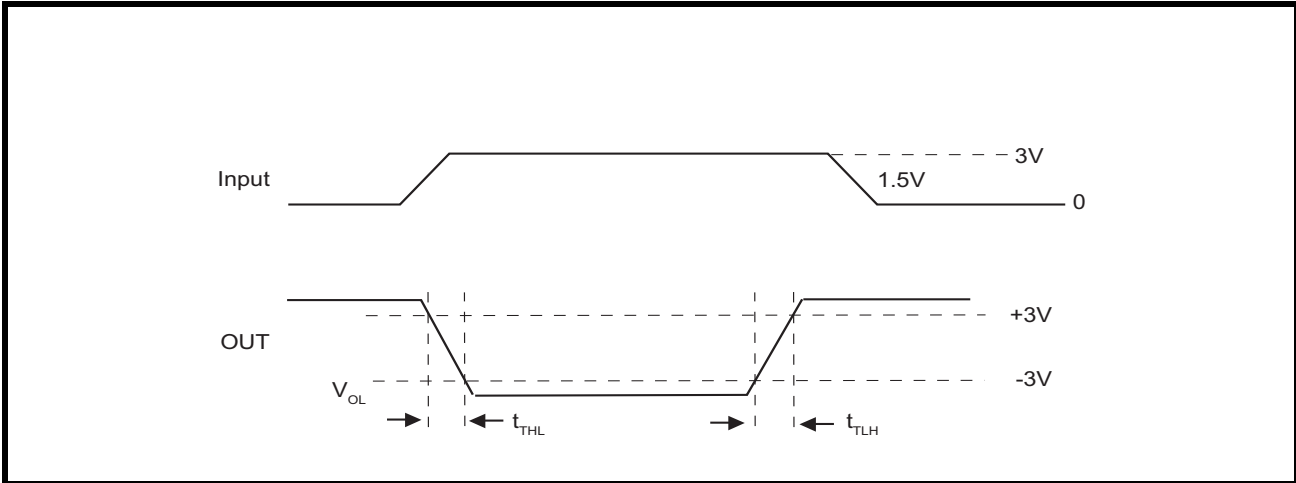

FIGURE 22. RS-232 RECEIVER PROPAGATION DELAY TEST CIRCUIT

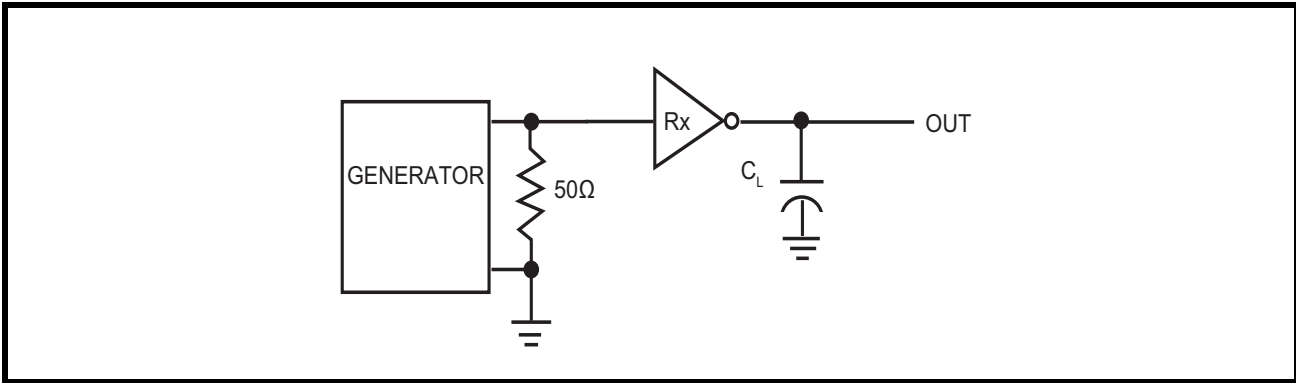
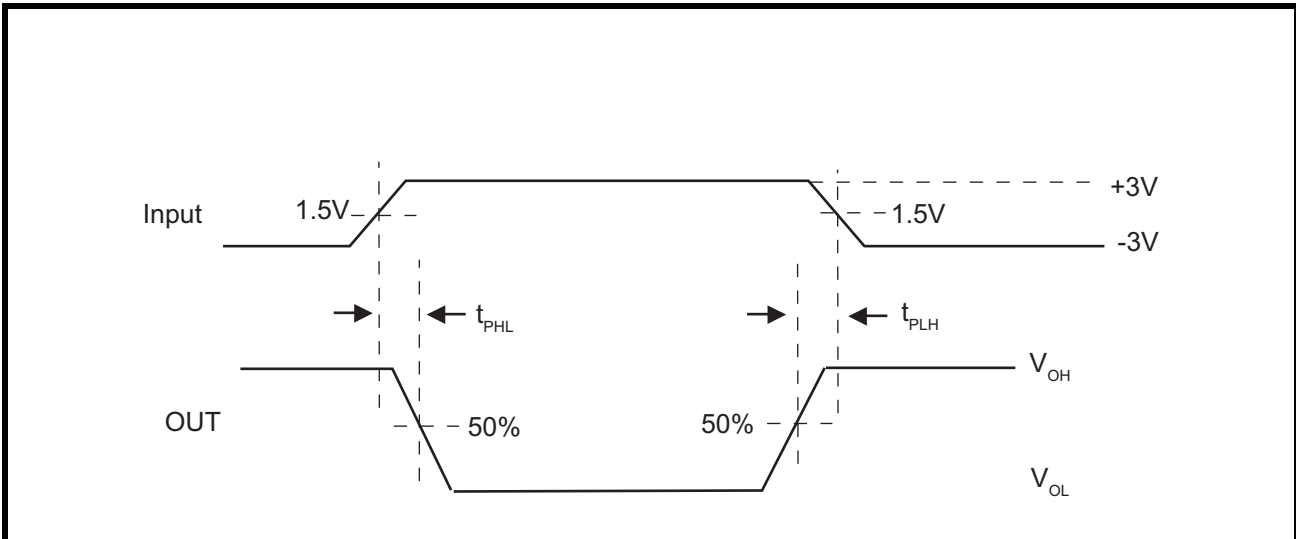

FIGURE 23. RS-232 RECEIVER PROPAGATION DELAY TIMING DIAGRAM



2.0 SUGGESTED APPLICATION DIAGRAMS

The SP336E supports all signals used in RS-232 over an 8 pin modular jack (RJ-45) as defined in TIA/EIA-561. For DTE serial port only three drivers are required. Driver_1 is not used in this configuration and its driver input should be tied to high or low.

SP336E may also be used to implement a standard serial port over a DB-9 connector (TIA/EIA-574 or the standard IBM serial port). In that case either DSR or RI signal can be supported. Both DSR and RI are used mainly for dial-up connections and are typically not needed on dedicated lines. If both signals are required, add a discrete transceiver such as SP3220E.

An alternative implementation would be to use the SP336E to emulate the functionality of two dual-channel RS-232 transceivers (2 x SP232's or equivalent).

Loop-Back

Changing from RS-232 mode (MODE 001) to loop-back mode (MODE 000) duplicates the function of an external loop-back plug. Loop-back can be used to test serial port functionality or to diagnose faults.

FIGURE 24. RS-232E SERIAL PORT (EIA-561 / EIA-574)

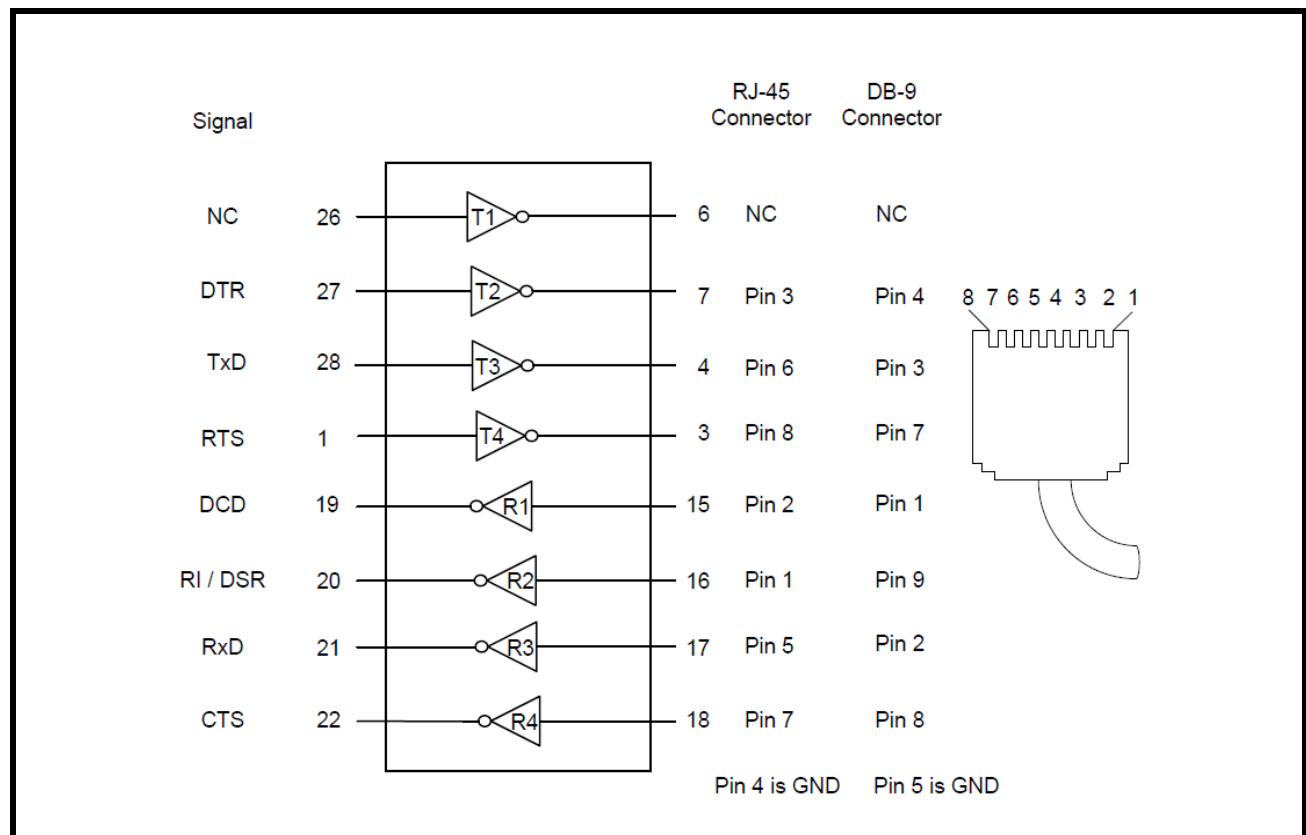

RS-232 to RS-485 Translator

SP336E can be used to implement a single-chip RS-232 to RS-485 translator function. Both full-duplex (4-wire RS-485) and half-duplex (2-wire RS-485) configurations are shown. RS-485 is capable of communicating on data cables up to 4000 feet (1200 meter) which makes it an ideal interface for extending the reach of short-range serial ports like RS-232. The configurations shown can be used to connect directly to existing PC type RS-232 serial ports to enable extended-reach communication.

The RTS signal (circuit CA or 105) is used as a transmit direction control signal for half-duplex. The ON condition puts the repeater into transmit mode and inhibits receive. On a half-duplex channel RxD should be held in MARK state (binary 1) when receiver 3 is inactive. Driver 1 on the SP336E can be used to generate DSR or CTS signal to indicate to the host terminal that the translator is powered-on and ready.

Shutdown Modes

SP336E features two shutdown modes. In mode 111 (full shutdown) all drivers and receivers are at high impedance. In mode 110, all drivers are tri-state but all four receivers remain active. In modes 101 and 100 two differential receivers can be kept active while the differential drivers are tri-stated using the Tx_EN inputs.

FIGURE 25. RS-232 / RS-485 TRANSLATOR FULL-DUPLEX CABLE-EXTENDER (MODE 011)

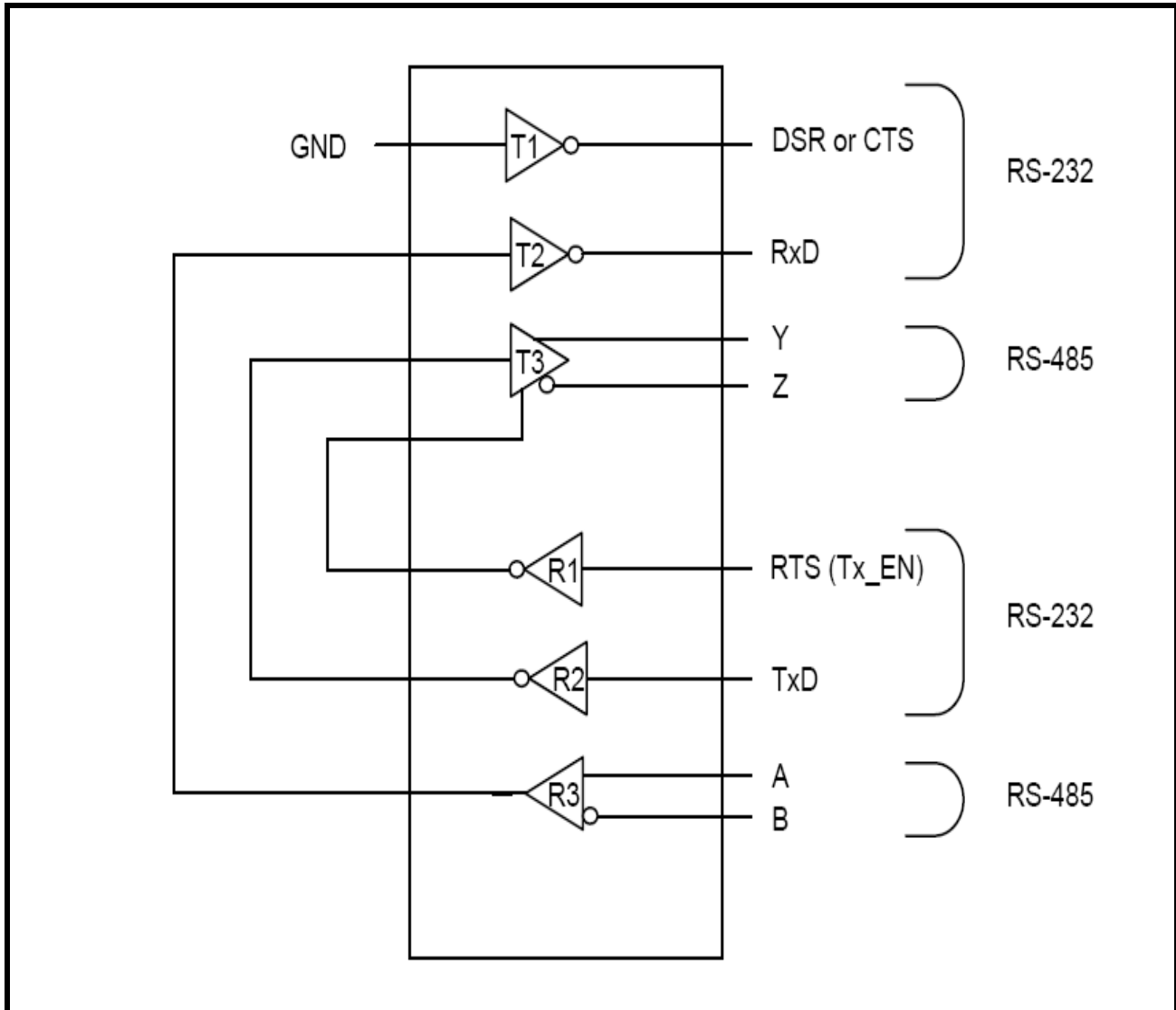
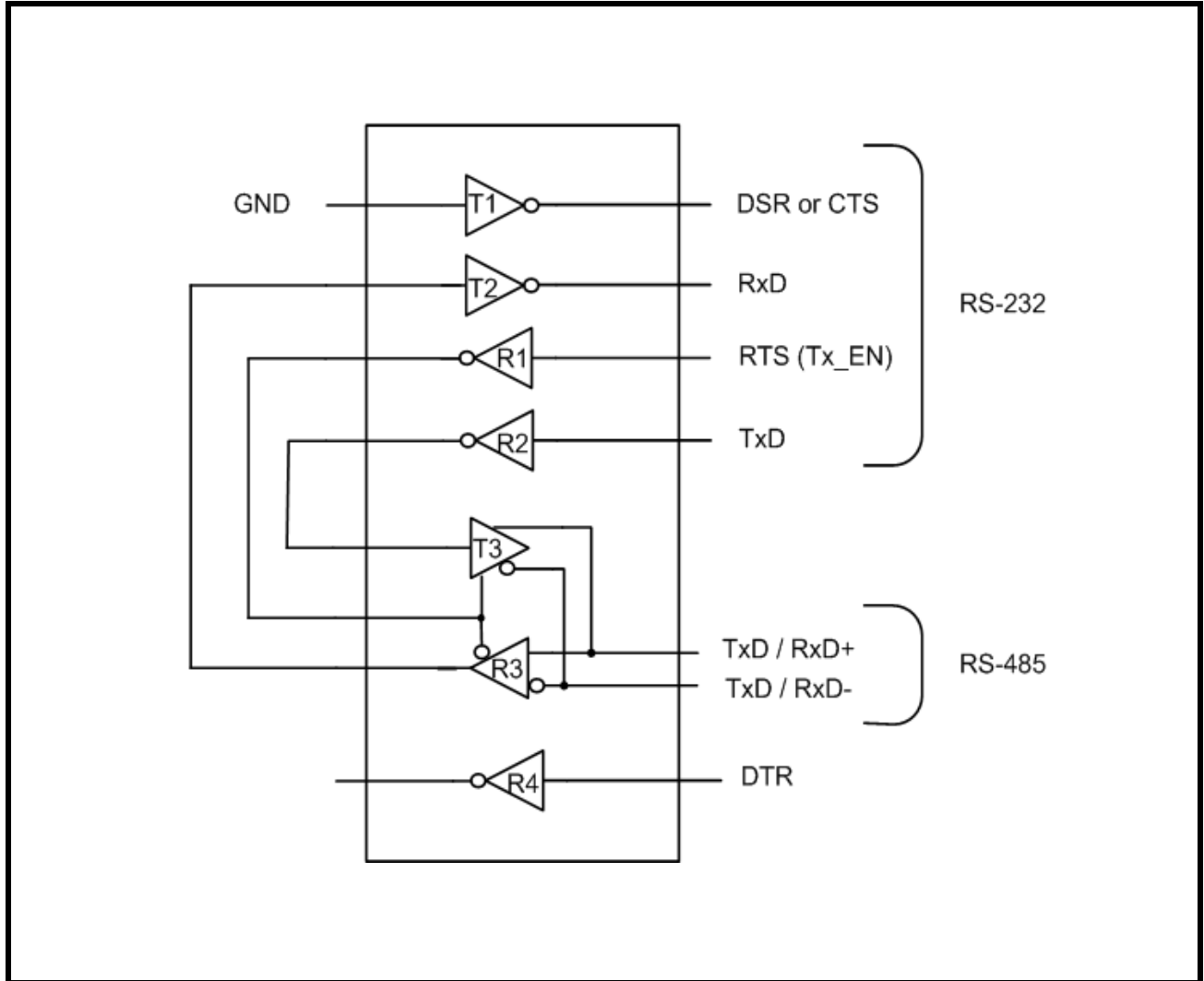

FIGURE 26. RS-232 / RS-485 TRANSLATOR HALF-DUPLEX CABLE-EXTENDER (MODE 010)



Bus Repeater

Mode 101 can be used as a bus-repeater to extend the reach of an RS-422 bus. This configuration is best suited for point-to-point or multi-drop communications because the drivers are always active and echoing data from their corresponding receiver.

For applications where multiple nodes are allowed to transmit, some type of bus arbitration should be used. One technique would be to use SP336E in conjunction with external decoder logic, packet buffers and node address fields embedded in the data stream. Receiving the correct node address triggers Tx_EN to pass data onward.

Mode 100 could implement a repeater / gateway to partition or extend RS-485 networks. Direction Control determines when data is forwarded to or from segments A and B.

FIGURE 27. RS-422 BUS-REPEATER (MODE 101)

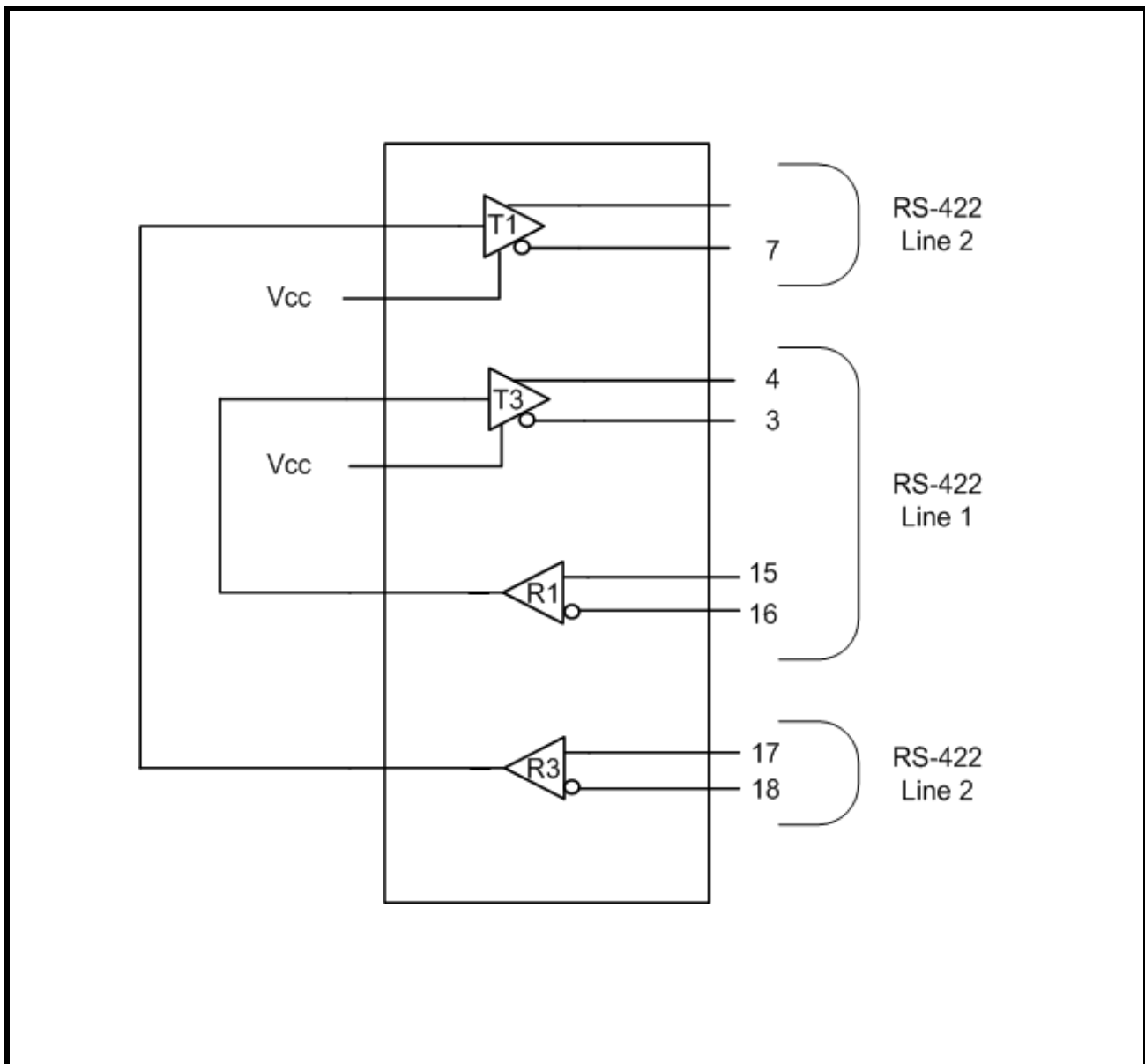

FIGURE 28. RS-485 BUS-REPEATER (MODE 100)

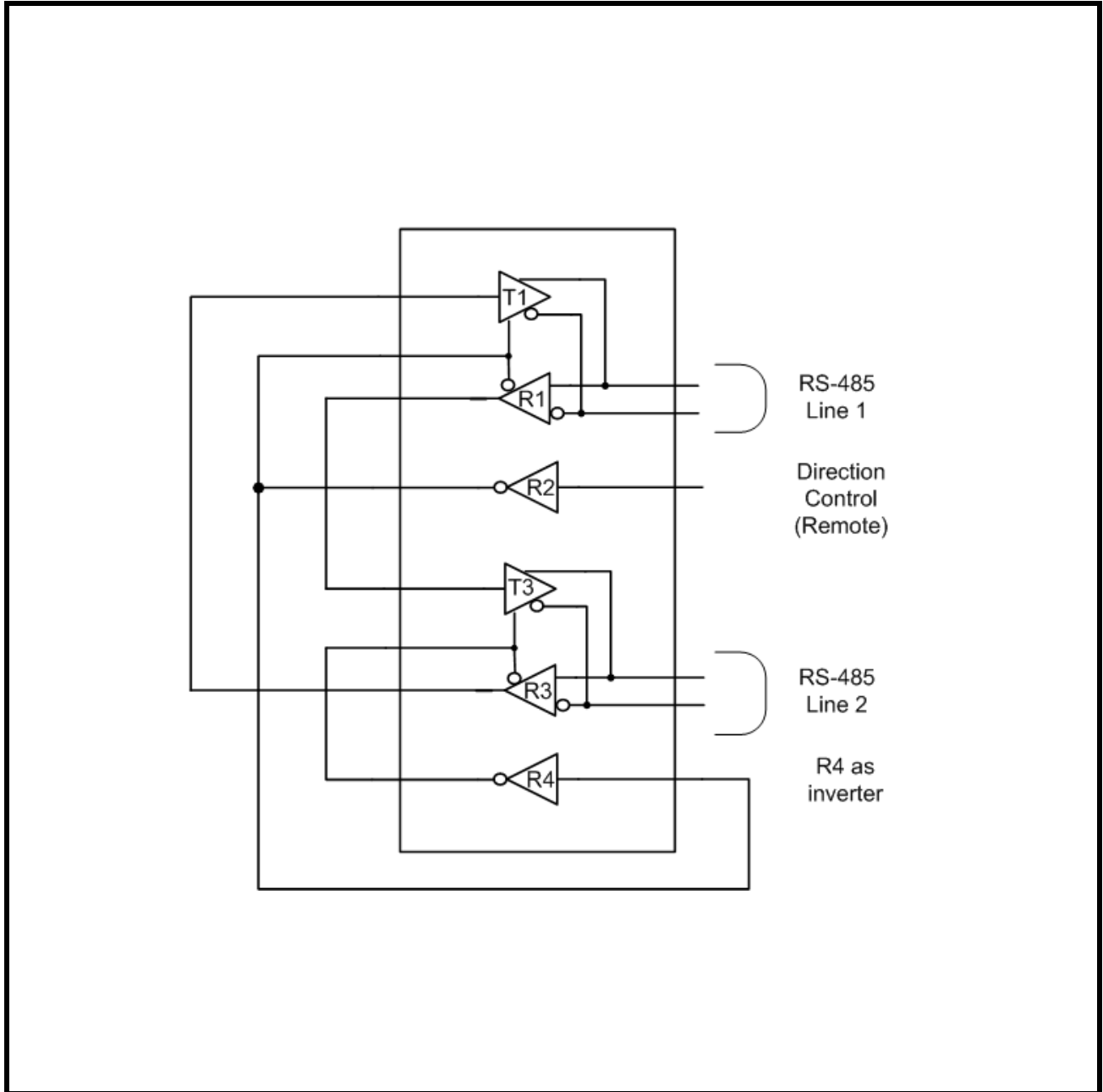
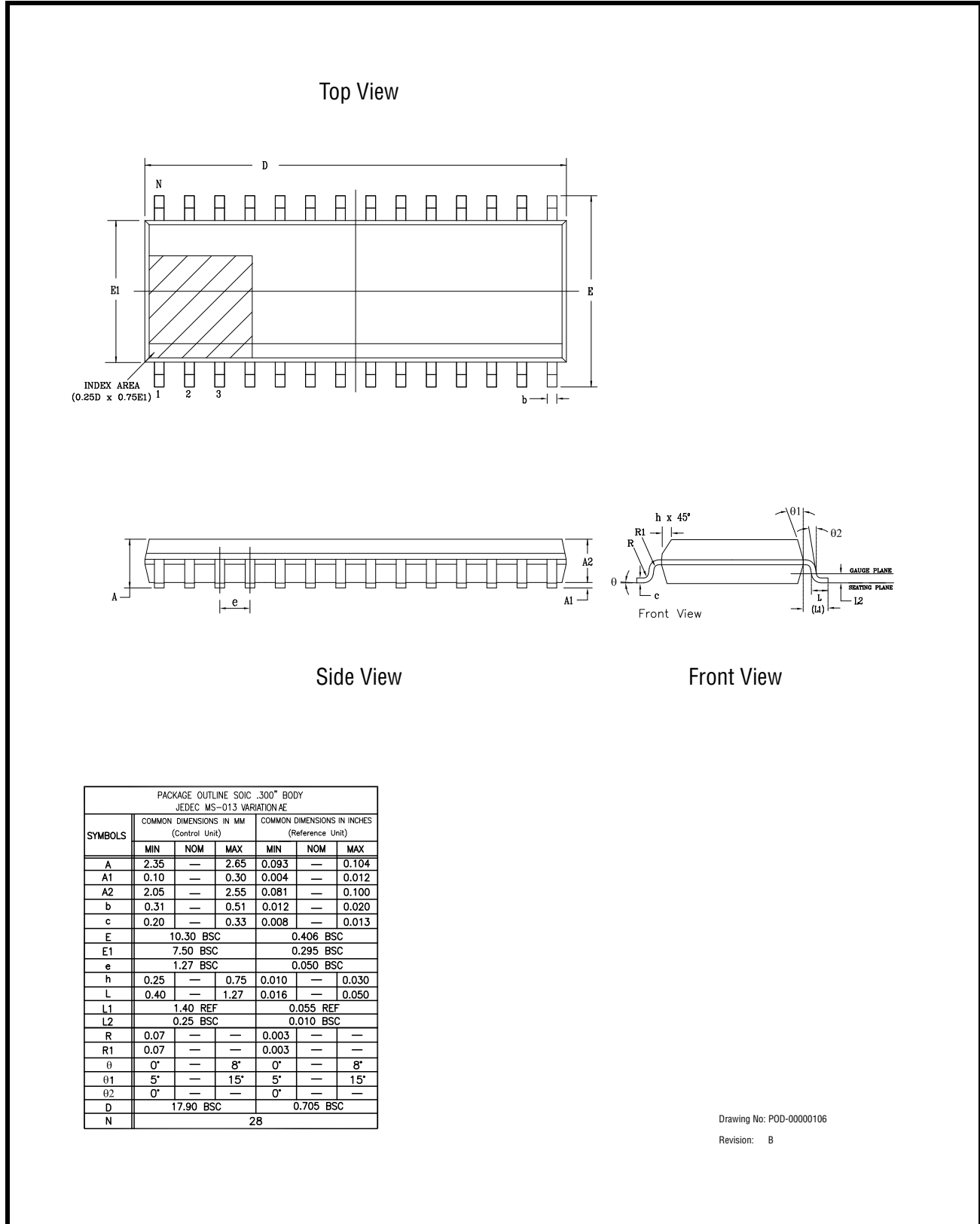

FIGURE 29. 28 PIN SOICW PACKAGE OUTLINE DRAWING



PACKAGE OUTLINE SOIC .300" BODY JEDEC MS-013 VARIATION AE						
SYMBOLS	COMMON DIMENSIONS IN MM (Control Unit)			COMMON DIMENSIONS IN INCHES (Reference Unit)		
	MIN	NOM	MAX	MIN	NOM	MAX
A	2.35	—	2.65	0.093	—	0.104
A1	0.10	—	0.30	0.004	—	0.012
A2	2.05	—	2.55	0.081	—	0.100
b	0.31	—	0.51	0.012	—	0.020
c	0.20	—	0.33	0.008	—	0.013
E	10.30 BSC			0.406 BSC		
E1	7.50 BSC			0.295 BSC		
e	1.27 BSC			0.050 BSC		
h	0.25	—	0.75	0.010	—	0.030
L	0.40	—	1.27	0.016	—	0.050
L1	1.40 REF			0.055 REF		
L2	0.25 BSC			0.010 BSC		
R	0.07	—	—	0.003	—	—
R1	0.07	—	—	0.003	—	—
θ	0°	—	8°	0°	—	8°
θ1	5°	—	15°	5°	—	15°
θ2	0°	—	—	0°	—	—
D	17.90 BSC			0.705 BSC		
N	28					

Drawing No: POD-00000106

Revision: B

FIGURE 30. 28 PIN TSSOP MECHANICAL DIMENSIONS

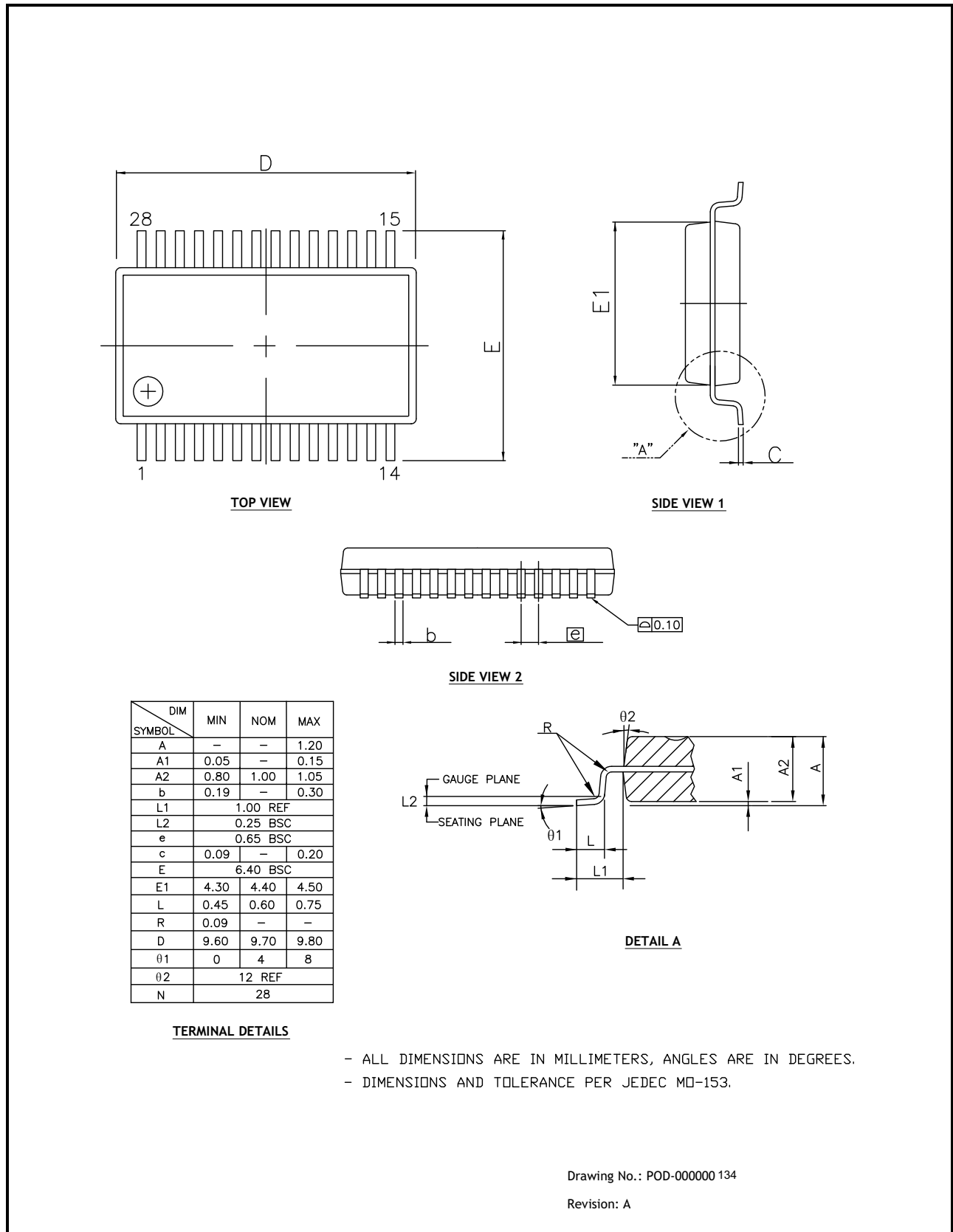
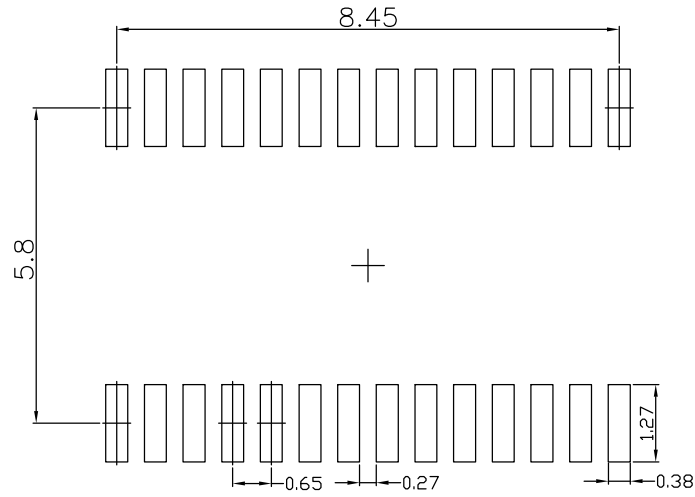
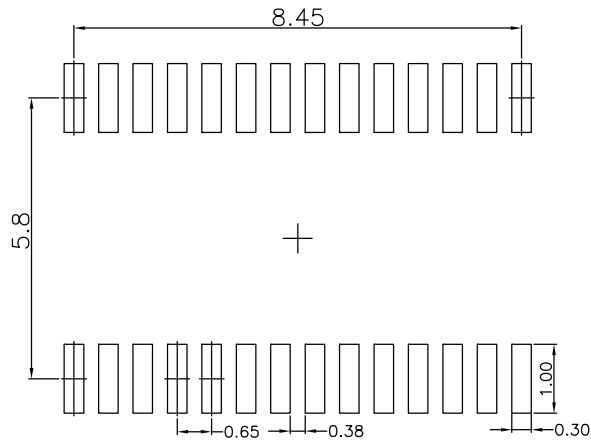

FIGURE 31. 28 PIN TSSOP RECOMMENDED LAND PATTERN AND STENCIL



TYPICAL RECOMMENDED LAND PATTERN



TYPICAL RECOMMENDED STENCIL

Drawing No.: POD-000000 134
Revision: A

REVISION HISTORY

DATE	REVISION	DESCRIPTION
March 2010	1.0.0	Production Release.
January 2011	1.0.1	RS-485/RS4-222 (Slew = GND, 250kbps, One Transmitter Switching) Driver Enable / Disable time maximum limit was changed from 900ns to 1500ns to better match the performance of the product. Add inverting symbol to all half-duplex receiver block diagram enable inputs. Update pin description table.
March 2018	1.1.0	Clarified test conditions for Driver Output Leakage Current on page 13. Updated to MaxLinear Logo. Update format and Ordering Information. Moved ESD ratings to Absolute Maximum Ratings section. V_O max (RS-232, no load) changed to $\pm 6.6V$.



Corporate Headquarters:

5966 La Place Court
 Suite 100
 Carlsbad, CA 92008
 Tel.: +1 (760) 692-0711
 Fax: +1 (760) 444-8598
www.maxlinear.com

High Performance Analog:

1060 Rincon Circle
 San Jose, CA 95131
 Tel.: +1 (669) 265-6100
 Fax: +1 (669) 265-6101
 Email: serialtechsupport@exar.com
www.exar.com

The content of this document is furnished for informational use only, is subject to change without notice, and should not be construed as a commitment by MaxLinear, Inc.. MaxLinear, Inc. assumes no responsibility or liability for any errors or inaccuracies that may appear in the informational content contained on this guide. Complying with all applicable copyright laws is the responsibility of the user.. Without limiting the rights under copyright, no part of this document may be reproduced into, stored in, or introduced into a retrieval system, or transmitted in any form or by any means (electronic, mechanical, photocopying, recording, or otherwise), or for any purpose, without the express written permission of MaxLinear, Inc.

MaxLinear, Inc. does not recommend the use of any of its products in life support applications where the failure or malfunction of the product can reasonably be expected to cause failure of the life support system or to significantly affect its safety or effectiveness. Products are not authorized for use in such applications unless MaxLinear, Inc. receives, in writing, assurances to its satisfaction that: (a) the risk of injury or damage has been minimized; (b) the user assumes all such risks; (c) potential liability of MaxLinear, Inc. is adequately protected under the circumstances.

MaxLinear, Inc. may have patents, patent applications, trademarks, copyrights, or other intellectual property rights covering subject matter in this document. Except as expressly provided in any written license agreement from MaxLinear, Inc., the furnishing of this document does not give you any license to these patents, trademarks, copyrights, or other intellectual property.

Company and product names may be registered trademarks or trademarks of the respective owners with which they are associated.

Looking for pricing, stock, or lifecycle information?

Click below to explore more details on WIN SOURCE:

 [View SP336ECY-L on WIN SOURCE](#)

 [Exar Corporation](#) Information

Optimize Your Supply Chain with WIN SOURCE Solutions

-  Global Sourcing Solution
-  Obsolete Management
-  Cost Control Management
-  Shortage Management
-  Alternative Solution
-  Excess Inventory Management