

SDP Biased Series - SOT23-6

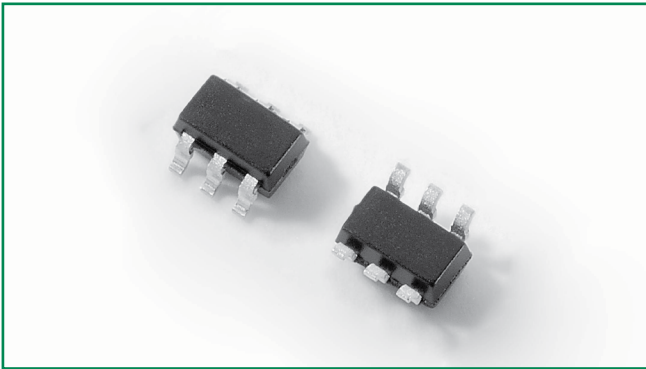

Description

This new SDP Biased series provides overvoltage protection for applications such as VDSL2, ADSL2, and ADSL2+ with minimal effect on data signals. This silicon design innovation results in a capacitive loading characteristic that is compatible with these high bandwidth applications. This surface mount SOT23-6 package provides a surge capability that exceeds most worldwide standards and recommendations for lightning surge withstand capability of tertiary protectors.

Features & Benefits

- Compatible with VDSL2 (30MHz) and with G.fast (106MHz)
- Response time under 500ns
- Balanced overvoltage protection
- RoHS Compliant
- Low distortion
- Pb-free E3 means 2nd level interconnect is Pb-free and the terminal finish material is tin(Sn) (IPC/JEDEC J-STD-609A.01)
- Low insertion loss
- Low profile

Agency Approvals

Agency	Agency File Number
	E133083

Pinout Designation & Schematic Symbol

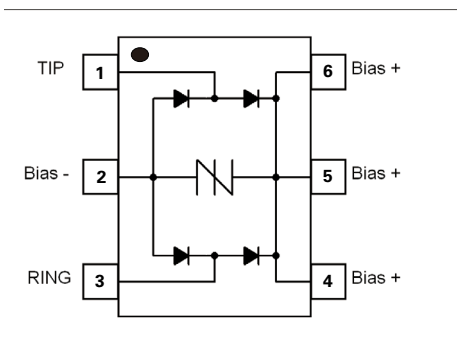

Applicable Global Standards

- ANSI C62.41
- IEC 61000-4-2 level 4 – 15kV (air discharge)
- IEC 61000-4-12
- IEC 61000-4-5, 30A – 8kV (contact discharge) ($t_p=8/20\mu s$) 2nd edition

Additional Information



Datasheet



Resources



Samples

Absolute Maximum Ratings between pin1 and pin 3, $T_a=25^\circ C$ (Unless otherwise noted)

Part Number	Marking	Maximum Junction Temperature	Storage Temperature Range	I_{PP} 8/20 μs
		$^\circ C$	$^\circ C$	A Max
SDP0240T023G6RP	P24	150	-65 to 150	30 ¹

Notes:

1. The device must be in thermal equilibrium at 25°C

Electrical Characteristics between pin 1 and pin 3, $T_a=25^\circ C$

Part Number	Marking	V_{DRM} @ $I_{DRM}=100nA$	I_{DRM} @ $V_{DRM}=19V$	V_s @ 1V/ μs	I_H	I_s	Co @ f=1MHz, 2V	Delta Co @ Line Bias = 1V to 19V
		V min	pA typ	V max	mA typ	mA min	pF max	pF max
SDP0240T023G6RP	P24	19	300	29	40	10	3.0	0.5

V-I: Characteristics

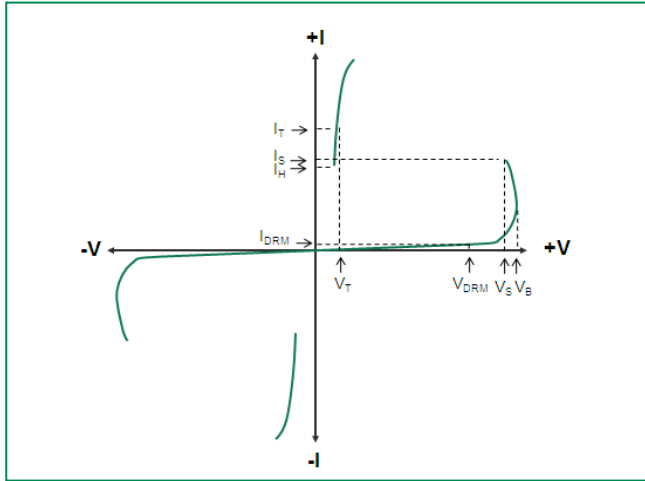

Typical capacitance against line voltage (without external bias)

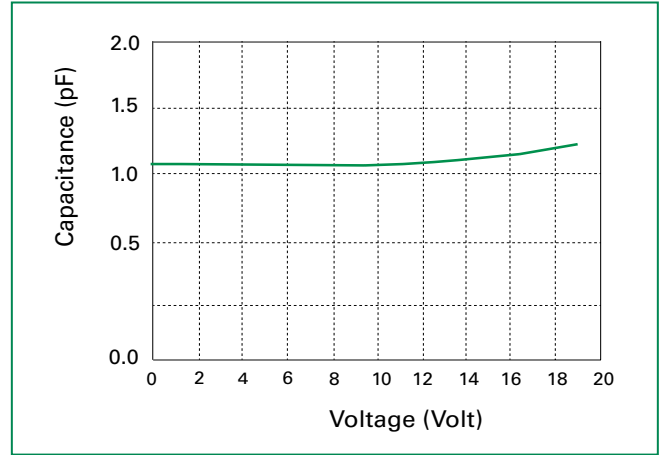

Surge Ratings

Series	I_{PP}
	$1.2/50\mu s^1 / 8/20\mu s^2$
	A min
G	30

Notes:

- 1 Voltage waveform in μs
- 2 Current waveform in μs

- Peak pulse current rating (I_{PP}) is repetitive and guaranteed for the life of the product that remains in thermal equilibrium.
- The component must be in thermal equilibrium at 25°C.

Thermal Information

Parameter	Rating	Units
Storage Temperature Range	-65 to 150	°C
Maximum Junction Temperature	150	°C
Maximum Lead Temperature (Soldering 10s)	260	°C

Normalized V_s Change vs. Junction Temperature

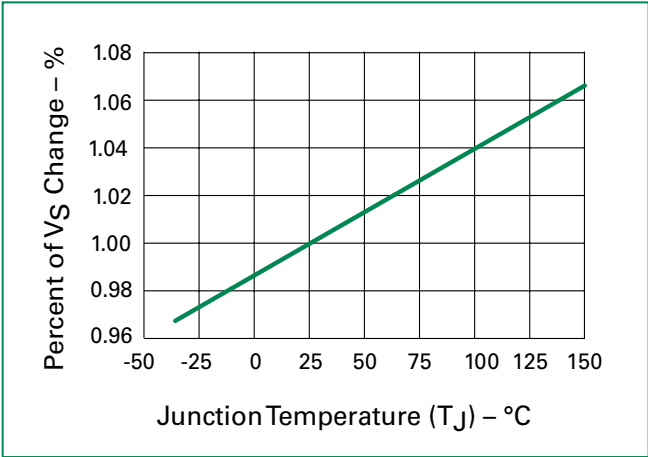

Normalized Holding Current vs. Case Temperature

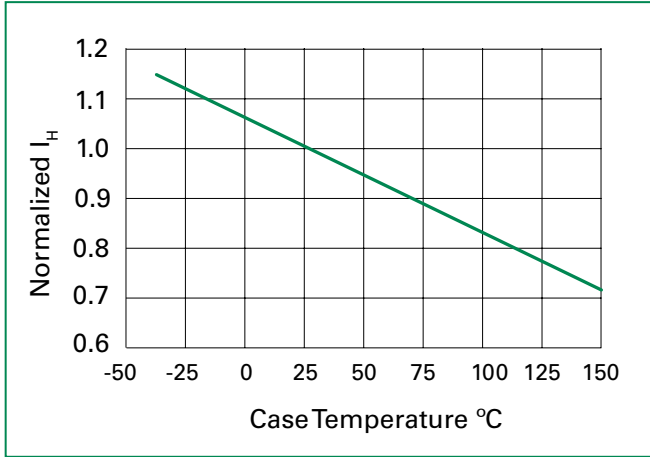

Soldering Parameters

Reflow Condition		Pb-Free assembly
Pre Heat	-Temperature Min ($T_{s(min)}$)	150°C
	-Temperature Max ($T_{s(max)}$)	200°C
	-Time (Min to Max) (t_s)	60-180 secs.
Average ramp up rate (Liquidus Temp (T_L) to peak)		3°C/sec. Max.
$T_{s(max)}$ to T_L - Ramp-up Rate		3°C/sec. Max.
Reflow	-Temperature (T_L) (Liquidus)	+217°C
	-Temperature (t_L)	60-150 secs.
Peak Temp (T_p)		250(+0/-5)°C
Time within 5°C of actual Peak Temp (t_p)		20-40 secs.
Ramp-down Rate		6°C/sec. Max.
Time 25°C to Peak Temp (T_p)		8 min. Max.
Do not exceed		260°C

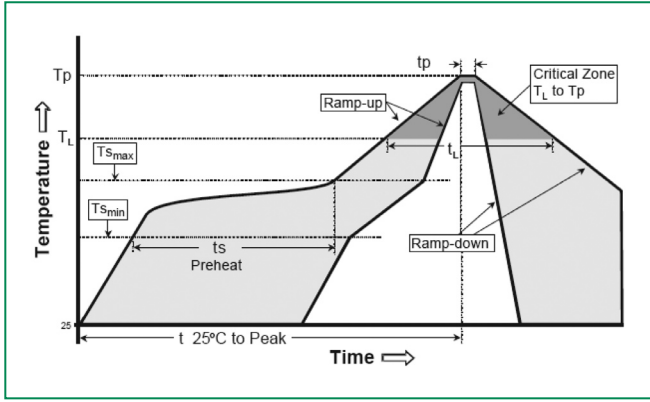

Physical Specifications

Lead Plating	SOT23: Matte Tin
Lead Material	Copper Alloy
Lead Coplanarity	0.0004 inches (0.102mm)
Substitute Material	Silicon
Body Material	Molded Epoxy
Flammability	V-0

- Notes:
1. All dimensions are in millimeters.
 2. Dimensions include solder plating.
 3. Dimensions are exclusive of mold flash & metal burr.
 4. All specifications comply to JEDEC MO-178
 5. Blo is facing up for mold and facing down for trim/form, i.e. reverse trim/form.
 6. Package surface matte tine

Environmental Specifications

Temp Cycling	Mil-STD-883, Method 1010.8 Condition C, -65°C to +150°C 168 Hrs, 85°C /60%RH+3IR-Reflow, 260°C +5V, -0°C
Bias Humidity	JESD 22-A101 85°C , 85%CRH. 50V 168 Hrs, 85°C /60%RH+3IR-Reflow, 260°C +5V, -0°C
Pressure Cooker	JEDEC 22-A102 No Bias, 121°C, 100%RH 96Hrs/192Hrs. 168 Hrs, 85°C /60%RH+3IR-Reflow, 260°C +5V, -0°C
High Temp Storage	JESD 22-A103 Con B. 150°C, no bias 1000Hrs
HTRB	JESD 22-108 168 Hrs, 85°C /60%RH+3IR-Reflow, 260°C +5V, -0°C
Thermal Shock	Mil-STD-883, Method 1011.9 Condition A, 0°C to 100°C 168 Hrs, 85°C /60%RH+3IR-Reflow, 260°C +5V, -0°C
C-SAM	As per flow, JSTD-020 pre&post preconditioning test.
Wet Humidity (Tin only)	JESD 201 standard: 55°C/85%RH

Dimensions - SOT23-6

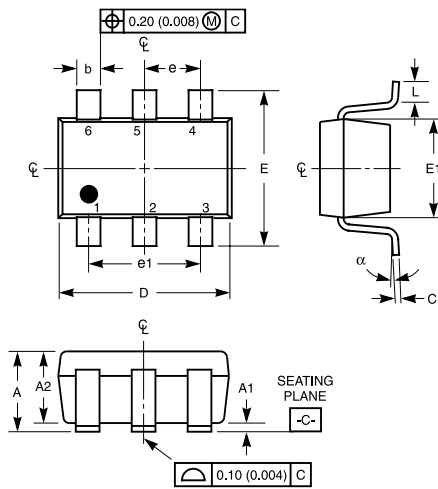

Recommended Solder Pad Layout

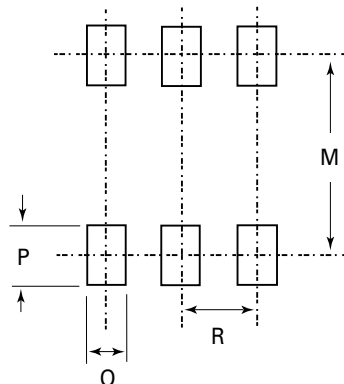

Dimensions	Inches		Millimeters	
	Min	Max	Min	Max
A	0.041	0.057	1.050	1.450
A1	0.000	0.006	0.000	0.150
A2	0.041	0.051	1.050	1.300
b	0.014	0.020	0.350	0.508
C	0.004	0.008	0.090	0.200
D	0.110	0.118	2.800	3.000
E	0.102	0.118	2.600	3.000
E1	0.057	0.069	1.450	1.750
e	0.037 (BSC)		0.950 (BSC)	
e1	0.071	0.075	1.800	1.900
L (note 4.5)	0.004	0.023	0.100	0.600
N (note 6)	6		6	
α	0°C	10°C	0°C	10°C
M	-	0.102	-	2.590
O	-	0.027	-	0.690
P	-	0.039	-	0.990
R	-	0.038	-	0.950

- Notes:
1. Dimensioning and tolerances per ANSI 14.5M-1982.
 2. Package conforms to EIAJ SC-74 (1992)
 3. Dimensions D and E1 are exclusive of mold flash, protrusions, or gate burrs.
 4. Foot length L measured at reference to seating plane.
 5. "L" is the length of flat foot surface for soldering to substrate.
 6. "N" is the number of terminal positions.
 7. Controlling dimension: MILLIMETER. Converted inch dimensions are not necessarily exact.

Part Numbering

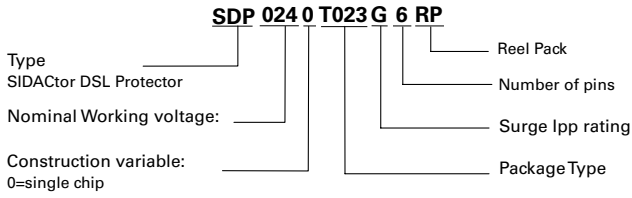

Part Marking

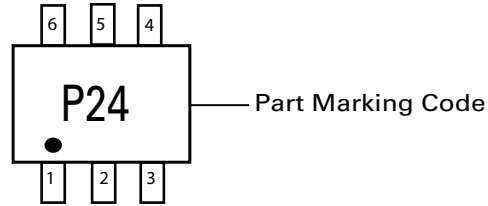

Packing Options

Package Type	Description	Quantity
SOT23-6	Tape and Reel	3000

Embossed Carrier Tape & Reel Specification - SOT23-6

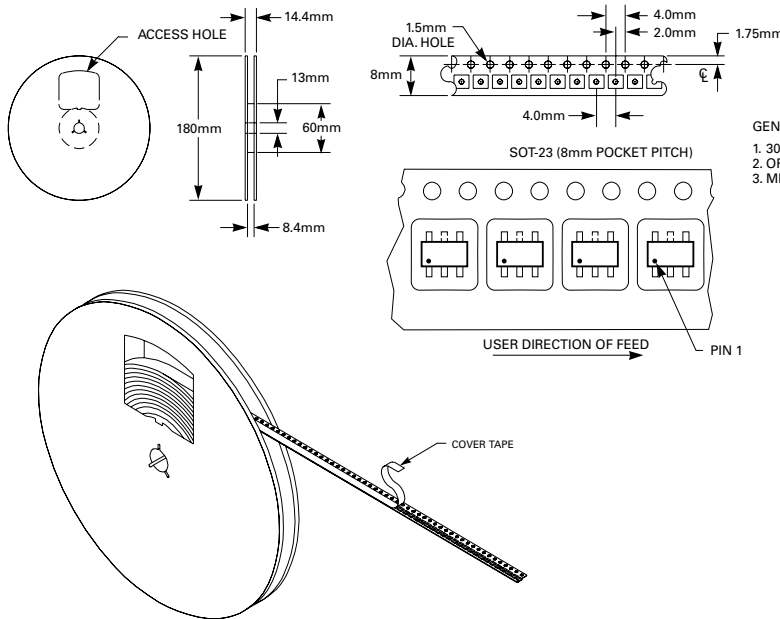

- GENERAL INFORMATION
1. 3000 PIECES PER REEL.
 2. ORDER IN MULTIPLES OF FULL REELS ONLY.
 3. MEETS EIA-481 REVISION "A" SPECIFICATIONS.

Disclaimer Notice - Information furnished is believed to be accurate and reliable. However, users should independently evaluate the suitability of and test each product selected for their own applications. Littelfuse products are not designed for, and may not be used in, all applications. Read complete Disclaimer Notice at www.littelfuse.com/disclaimer-electronics.

Looking for pricing, stock, or lifecycle information?

Click below to explore more details on WIN SOURCE:

 [View SDP0240T023G6RP on WIN SOURCE](#)

 [Littelfuse Inc. Information](#)

Optimize Your Supply Chain with WIN SOURCE Solutions

-  Global Sourcing Solution
-  Obsolete Management
-  Cost Control Management
-  Shortage Management
-  Alternative Solution
-  Excess Inventory Management