



**THE DATASHEET OF
TPS65320BQPWPRQ1**



TPS65320-Q1 40-V Step-Down Converter With Eco-mode™ and LDO Regulator

1 Features

- Qualified for Automotive Applications
- AEC-Q100 Qualified With the Following Results:
 - Device Temperature Grade 1: –40°C to +125°C Ambient Operating Temperature
 - Device HBM ESD Classification Level 2
 - Device CDM ESD Classification Level C4B
- One High-VIN Step-Down Converter
 - 3.6- to 40-V Input Range
 - 250-mΩ High-Side MOSFET
 - 3.2-A Maximum Load Current, 1.1- to 20-V Output Adjustable
 - 100-kHz to 2.5-MHz Adjustable Switch-Mode Frequency
 - Less Than 140-μA Operating Quiescent Current
- One Low-Dropout Voltage Regulator (LDO)
 - 280-mA Current Capability With 28-μA (Typical) Operating Quiescent Current in No-Load Condition
 - Input Supply Auto-Source to Balance Efficiency and Low Standby Current
 - Power-Good Output (Push-Pull)
 - Low-Dropout Voltage of 300 mV at $I_{OUT} = 200$ mA (Typical)
- Overcurrent Protection for Both Regulators
- Overtemperature Protection
- 14-Pin HTSSOP Package With PowerPAD™ Package

2 Applications

- Automotive Infotainment and Cluster
- Advanced Driver Assistance System (ADAS)
- Telematics

3 Description

The TPS65320-Q1 device is a combination of a 40-V, 3.2-A, DC-DC step-down converter and a low-dropout (LDO) regulator. The DC-DC step-down converter, referred to as the buck regulator, has an integrated high-side MOSFET. The LDO regulator also has an integrated MOSFET and a low-input supply current of 28-μA (typical) in a no-load condition. Furthermore, the LDO regulator has an active-low, push-pull reset output pin. To reduce heat, the input supply of the LDO regulator can auto-source from the input voltage to the output of the buck regulator. The low-voltage tracking feature can eliminate the need to use a boost converter during cold-crank conditions.

The buck regulator has a switching frequency range from 100 kHz to 2.5 MHz that provides a flexible design to fix system requirements. The external loop compensation allows for optimization of the converter response for the appropriate operating conditions. A low-ripple pulse-skip mode reduces the no-load input supply current to less than 140 μA.

The device has built-in protection features such as soft start, current limit, thermal sensing, and shutdown because of excessive power dissipation. Furthermore, the device has an internal undervoltage-lockout (UVLO) function that turns off the device at a too-low supply voltage.

Device Information⁽¹⁾

PART NUMBER	PACKAGE	BODY SIZE (NOM)
TPS65320-Q1	HTSSOP (14)	5.00 mm x 4.40 mm

(1) For all available packages, see the orderable addendum at the end of the data sheet.

Typical Application Schematic

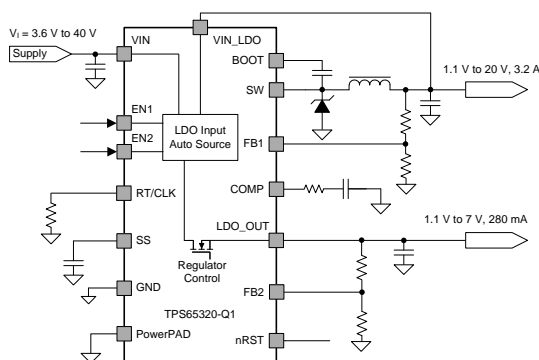

Buck Efficiency Versus Output Current

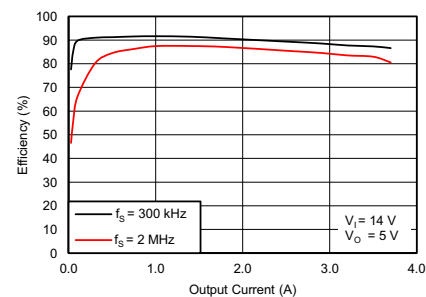

• Added the Initial start-up voltage parameter	6
• Changed the MIN value of the Internal UVLO rising threshold parameter from 2.5 to 2.2	6
• Changed the MIN value of the Operating input voltage (VIN_LDO) from 4 to 3	7
• Updated the FB2 voltage reference test condition	7
• Changed the MAX value of the Quiescent current parameter from 40 to 75 and add T _J to test condition	7
• Added the V _(LDO_OUT) value to the Output capacitor parameter test conditions	7
• Changed the TYP value for the Thermal-shutdown trip point from 170 to 155	7
• Changed the minimum value of the soft-start capacitor from 0.47 nF to 1 nF in the <i>Soft-Start and Tracking Pin (SS/TR)</i> section	13
• Changed the 300-kHz switching frequency application to 500-kHz switching frequency <i>Design Example With 300-kHz Switching Frequency</i> section	31

Changes from Revision A (April 2013) to Revision B
Page

• Deleted the word, <i>Codec</i> , from document title	1
• Changed first bullet item in <i>APPLICATIONS</i> from <i>Qualified for Automotive Applications</i> to <i>Automotive</i>	1
• Added min value for I _{SS} parameter in <i>ELECTRICAL CHARACTERISTICS</i> table	7
• Added test condition to Output high parameter under RESET (nRST PIN) in <i>ELECTRICAL CHARACTERISTICS</i> table....	7
• Added push-pull stage and nRS release text to <i>Power-Good Output, nRST</i> section	20

5 Pin Configuration and Functions

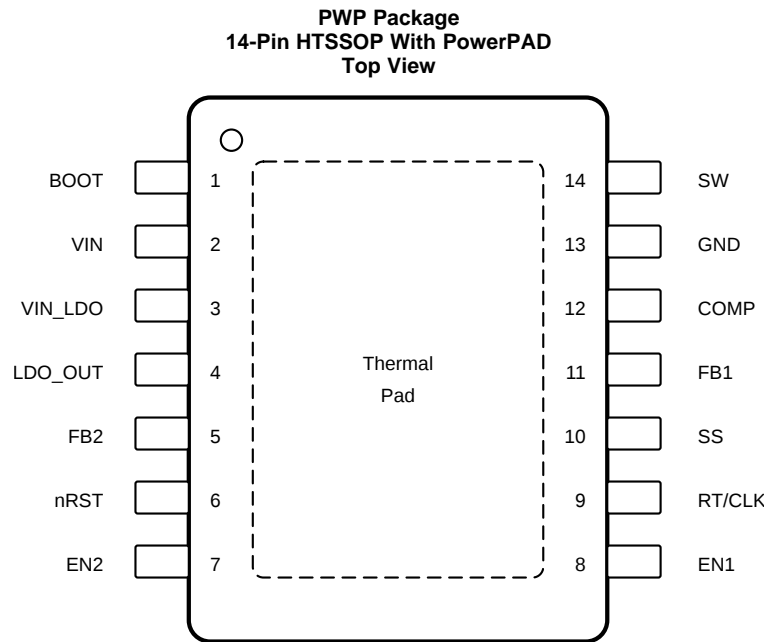

Pin Functions

PIN		I/O	DESCRIPTION
NAME	NO.		
BOOT	1	O	A bootstrap capacitor is required between the BOOT and SW pins to supply the bias voltage for the integrated high-side MOSFET.
COMP	12	O	Error-amplifier output of the buck regulator, and input to the output-switch current comparator of the buck regulator. Connect frequency-compensation components to the COMP pin.
EN1	8	I	Enable and disable input for the buck regulator (high-voltage tolerant) internally pulls to ground. Pull this pin up externally to enable the buck regulator.
EN2	7	I	Enable and disable input for the LDO regulator (high-voltage tolerant) internally pulls to ground. Pull this pin up externally to enable the LDO regulator.
FB1	11	I	Feedback pin of the buck regulator. Connect an external resistive divider between the buck regulator output, FB2, and GND to set the desired output voltage of the buck regulator.
FB2	5	I	Feedback pin of the LDO regulator. Connect an external resistive divider between LDO_OUT, FB2, and GND for setting the desired output voltage of the LDO regulator
GND	13	—	Ground
LDO_OUT	4	O	LDO regulator output
nRST	6	O	Active-low, push-pull reset output of the LDO regulator. Connect this pin with an external bias voltage through an external resistor. This pin is asserted high after the LDO regulator begins regulating.
RT/CLK	9	I	External resistor connected to ground to program the switching frequency of the buck regulator. An alternative option is to feed an external clock to provide a reference for the switching frequency of the buck regulator.
SS	10	I	External capacitor to ground that sets the soft-start time of the buck regulator
SW	14	I	Source node of the internal high-side MOSFET of the buck regulator
VIN	2	—	Input supply pin for the internal biasing and high-side MOSFET of the buck regulator
VIN_LDO	3	—	Input supply pin for the LDO regulator
Exposed PowerPAD	—	—	Electrically connect the PowerPAD to ground. Solder the PowerPAD to the ground plane of the PCB for thermal performance.

6 Specifications

6.1 Absolute Maximum Ratings

over operating free-air temperature range (unless otherwise noted)⁽¹⁾

		MIN	MAX	UNIT
Supply inputs	VIN	-0.3	45	V
	VIN_LDO	-0.3	20	
	VIN – VIN_LDO	-0.3	45	
Control	EN1, EN2	-0.3	45	V
	EN1-VIN, EN2-VIN		1	
Buck converter	FB1	-0.3	3.6	V
	SW	-0.3 -2 V for 30 ns	40	
	BOOT	-0.3	46	
	BOOT-SW		8	
	COMP	-0.3	3.6	
	SS	-0.3	3.6	
	RT/CLK, SS	-0.3	3.6	
LDO regulator	LDO_OUT	-0.3	7	V
	FB2	-0.3	7	
	nRST	-0.3	7	
Operating ambient temperature, T _A		-40	125	°C
Operating junction temperature, T _J		-40	150	
Storage temperature, T _{stg}		-55	165	

(1) Stresses beyond those listed under *Absolute Maximum Ratings* may cause permanent damage to the device. These are stress ratings only, and functional operation of the device at these or any other conditions beyond those indicated under *Recommended Operating Conditions* is not implied. Exposure to absolute-maximum-rated conditions for extended periods may affect device reliability.

6.2 ESD Ratings

			VALUE	UNIT	
V _(ESD)	Electrostatic discharge	Human-body model (HBM), per AEC Q100-002 ⁽¹⁾	±2000	V	
		Charged-device model (CDM), per AEC Q100-011	All pins		±500
			Corner pins (1, 7, 8, and 14)		±750

(1) AEC Q100-002 indicates that HBM stressing shall be in accordance with the ANSI/ESDA/JEDEC JS-001 specification.

6.3 Recommended Operating Conditions

over operating free-air temperature range (unless otherwise noted)

		MIN	MAX	UNIT
Supply inputs	VIN	3.6	40	V
	VIN_LDO	3	20	
Buck regulator	BOOT1	3.6	46	V
	SW1	-1	40	
	VFB1	0	3	
	SS	0	3	
	COMP	0	3	
	RT/CLK	0	3	
LDO regulator	LDO_OUT	1.1	5.5	V
	VFB2	0	5.25	
	nRST	0	5.25	

Recommended Operating Conditions (continued)

over operating free-air temperature range (unless otherwise noted)

		MIN	MAX	UNIT
Control	EN1	0	40	V
	EN2	0	40	
Operating junction temperature, T _J		-40	150	°C

6.4 Thermal Information

THERMAL METRIC ⁽¹⁾		TPS65320-Q1	UNIT
		PWP (HTSSOP)	
		14 PINS	
R _{θJA}	Junction-to-ambient thermal resistance	49.9	°C/W
R _{θJC(top)}	Junction-to-case (top) thermal resistance	31	°C/W
R _{θJB}	Junction-to-board thermal resistance	26.6	°C/W
Ψ _{JT}	Junction-to-top characterization parameter	1	°C/W
Ψ _{JB}	Junction-to-board characterization parameter	26.4	°C/W
R _{θJC(bot)}	Junction-to-case (bottom) thermal resistance	3.7	°C/W

(1) For more information about traditional and new thermal metrics, see the *Semiconductor and IC Package Thermal Metrics* application report, [SPRS953](#).

6.5 Electrical Characteristics

V_I = 6 V to 27 V, EN1 = EN2 = V_I, over-operating free-air temperature range T_A = -40°C to +125°C and maximum operating junction temperature T_J = -40°C to +150°C, unless otherwise noted. V_I is the voltage on the battery-supply pins, VIN and VIN_LDO.

PARAMETER	TEST CONDITIONS	MIN	TYP	MAX	UNIT	
VIN (INPUT POWER SUPPLY)						
Operating input voltage	Normal mode, after initial start-up	3.6	14	40	V	
Shutdown supply current	V _(EN1) = V _(EN2) = 0 V, 25°C		2	7	μA	
Initial start-up voltage		6		40	V	
ENABLE AND UVLO (EN1 AND EN2 PINS)						
Enable low level				0.7	V	
Enable high level		2.5			V	
V _{(VIN)(f)}	Internal UVLO falling threshold	Ramp V _(VIN) down until output turns OFF	2	2.6	3	V
V _{(VIN)(r)}	Internal UVLO rising threshold	Ramp V _(VIN) up until output turns ON	2.2	2.8	3.2	V
BUCK REGULATOR						
Operating: non-switching supply	V _(FB1) = 0.83 V, V _(VIN) = 12 V, 25°C		110	140	μA	
Output capacitor	ESR = 0.001 Ω to 0.1 Ω, large output capacitance may be required for load transient	10			μF	
BUCK REGULATOR: HIGH-SIDE MOSFET						
On-resistance	V _(VIN) = 12 V, V _(SW) = 6 V		127	250	mΩ	
BUCK REGULATOR: ERROR AMPLIFIER						
Input current			50		nA	
Error-amplifier transconductance (gm)	-2 μA < I _(COMP) < 2 μA, V _(COMP) = 1 V		310		μS	
Error-amplifier transconductance (gm) during soft start	-2 μA < I _(COMP) < 2 μA, V _(COMP) = 1 V V _(FB1) = 0.4 V		70		μS	
Error-amplifier dc gain	V _(FB1) = 0.8 V		100		dB	
Error-amplifier bandwidth			6000		kHz	
Error-amplifier source or sink	V _(COMP) = 1 V, 100-mV overdrive		±27		μA	

Electrical Characteristics (continued)

$V_I = 6\text{ V to }27\text{ V}$, $EN1 = EN2 = V_I$, over-operating free-air temperature range $T_A = -40^\circ\text{C to }+125^\circ\text{C}$ and maximum operating junction temperature $T_J = -40^\circ\text{C to }+150^\circ\text{C}$, unless otherwise noted. V_I is the voltage on the battery-supply pins, V_{IN} and V_{IN_LDO} .

PARAMETER		TEST CONDITIONS	MIN	TYP	MAX	UNIT
	COMP to switch-current transconductance			10.5		S
V_{ref1}	Voltage reference for FB1 pin	Buck regulator output: 3.6 V to 10 V	0.788	0.8	0.812	V
BUCK REGULATOR: CURRENT-LIMIT						
	Current-limit threshold	$V_{(VIN)} = 12\text{ V}$, $T_J = 25^\circ\text{C}$	4	6		A
BUCK REGULATOR: TIMING RESISTOR AND EXTERNAL CLOCK (RT/CLK PIN)						
RT/CLK	High threshold			1.9	2.2	V
RT/CLK	Low threshold		0.5	0.7		V
BUCK REGULATOR: INTERNAL SOFT START TIMER						
$I_{S(SS)}$	Soft-start source current	$V_{(SS)} = 0\text{ V}$	1	2	4	μA
LDO REGULATOR						
$\Delta V_{O(\Delta V_I)}$	Line regulation	$V_{(VIN)} = 6\text{ V to }30\text{ V}$, $I_{(LDO_OUT)} = 10\text{ mA}$, $V_{(LDO_OUT)} = 3.3\text{ V}$			20	mV
$\Delta V_{O(\Delta I_L)}$	Load regulation	$I_{(LDO_OUT)} = 10\text{ mA to }200\text{ mA}$, $V_{(VIN_LDO)} = 14\text{ V}$, $V_{(LDO_OUT)} = 3.3\text{ V}$			35	mV
$V_{DROPOUT}$ ($V_{(VIN_LDO)}$ – $V_{(LDO_OUT)}$)	Dropout voltage	$I_{(LDO_OUT)} = 200\text{ mA}$		300	450	mV
$I_{(LDO_OUT)}$	Output current	$V_{(LDO_OUT)}$ in regulation	0		280	mA
	Error-amplifier dc gain			800		V/V
$V_{(VIN_LDO)}$	Operating input voltage on V_{IN_LDO} pin	Buck regulator is in regulation and supplying at least LDO output plus dropout voltage $V_{DROPOUT}$	3		20	V
V_{ref2}	Voltage reference for FB2 pin	$V_{(LDO_OUT)} = 1.2\text{ V to }5\text{ V}$	0.788	0.8	0.812	V
$I_{CL(LDO_OUT)}$	Output current limit	$V_{(LDO_OUT)} = 0\text{ V}$ (LDO_OUT pin is shorted to ground.)	280		1000	mA
$I_{Q(LDO)}$	Quiescent current	$V_{(VIN)} > 9\text{ V}$, $V_{(EN1)} = 0\text{ V}$, $V_{(EN2)} = 5\text{ V}$, $I_{(LDO_OUT)} = 0.01\text{ mA to }0.75\text{ mA}$, $T_J = 25^\circ\text{C}$		28	75	μA
PSRR	Power supply ripple rejection	$V_{(VIN_LDO)(rip)} = 0.5\text{ V}_{PP}$, $I_{(LDO_OUT)} = 200\text{ mA}$, frequency = 100 Hz, $V_{(LDO_OUT)} = 5\text{ V}$ and $V_{(LDO_OUT)} = 3.3\text{ V}$		60		dB
PSRR	Power supply ripple rejection	$V_{(VIN_LDO)(rip)} = 0.5\text{ V}_{PP}$, $I_{(LDO_OUT)} = 200\text{ mA}$, frequency = 150 kHz, $V_{(LDO_OUT)} = 5\text{ V}$ and $V_{(LDO_OUT)} = 3.3\text{ V}$		30		dB
	Output capacitor	ESR = 0.001 Ω to 100 m Ω , large output capacitance may be required for load transient, $V_{(LDO_OUT)} \geq 3.3\text{ V}$	1		40	μF
		ESR = 0.001 Ω to 100 m Ω , large output capacitance may be required for load transient, $1.2\text{ V} \leq V_{(LDO_OUT)} < 3.3\text{ V}$	20		40	μF
LDO REGULATOR: RESET (nRST PIN)						
	RESET threshold	$V_{(LDO_OUT)}$ decreasing	88%	92%	95%	
V_{OH}	Output high	Reset released due to rising LDO_OUT , $V_{(LDO_OUT)} \geq 3.3\text{ V}$, $I_{OH} = 100\text{ }\mu\text{A}$		$-5\% \times V_{(LDO_OUT)}$		V
V_{OL}	Output low	Reset asserted due to falling LDO_OUT , $I_{OL} = 1\text{ mA}$	0	0.045	0.4	V
OVERTEMPERATURE PROTECTION						
T_{SD}	Thermal-shutdown trip point			155		$^\circ\text{C}$
T_{hys}	Hysteresis			10		$^\circ\text{C}$

6.6 Timing Requirements

$V_I = 6\text{ V to }27\text{ V}$, $EN1 = EN2 = V_I$, over-operating free-air temperature range $T_A = -40^\circ\text{C to }+125^\circ\text{C}$ and maximum operating junction temperature $T_J = -40^\circ\text{C to }+150^\circ\text{C}$, unless otherwise noted

	MIN	TYP	MAX	UNIT
BUCK REGULATOR: TIMING RESISTOR AND EXTERNAL CLOCK (RT/CLK PIN)				
Minimum CLK input pulse width		40		ns

6.7 Switching Characteristics

$V_I = 6\text{ V to }27\text{ V}$, $EN1 = EN2 = V_I$, over-operating free-air temperature range $T_A = -40^\circ\text{C to }+125^\circ\text{C}$ and maximum operating junction temperature $T_J = -40^\circ\text{C to }+150^\circ\text{C}$, unless otherwise noted

PARAMETER	TEST CONDITIONS	MIN	TYP	MAX	UNIT
BUCK REGULATOR: HIGH-SIDE MOSFET					
t_{onmin} Minimum on-time	$f_S = 2.5\text{ MHz}$		100		ns
BUCK REGULATOR: TIMING RESISTOR AND EXTERNAL CLOCK (RT/CLK PIN)					
f_S Switching-frequency range using RT mode		100		2500	kHz
f_S Switching frequency	200 k Ω connected between pin RT/CLK and GND	450	581	720	kHz
f_S Switching-frequency range using CLK mode		300		2200	kHz
RT/CLK Falling edge to SW rising edge delay	Measured at 500 kHz with 200-k Ω series resistor connected to RT/CLK pin		60		ns
PLL Lock-in time	Measured at 500 kHz		100		μs
LDO REGULATOR: RESET (nRST PIN)					
Filter time	Delay before asserting nRST low	6	10	15	μs

6.8 Typical Characteristics

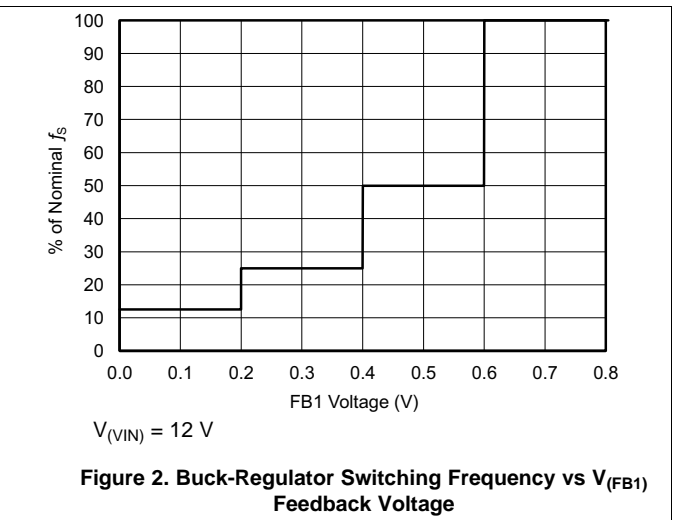
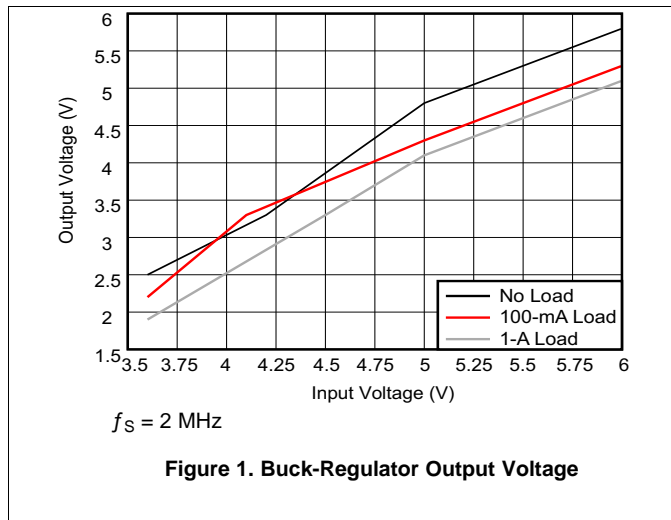

Typical Characteristics (continued)

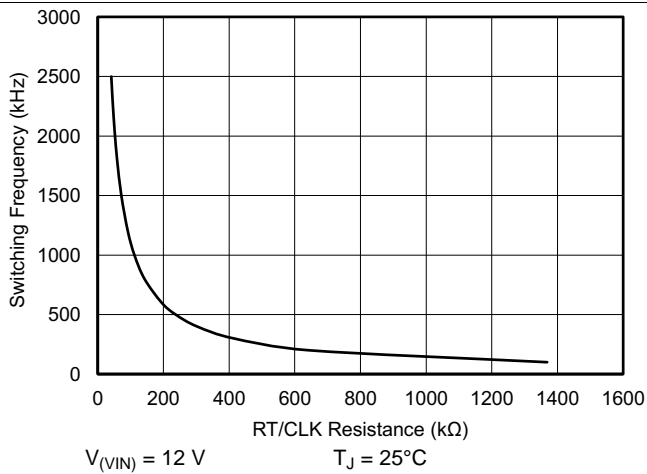

Figure 3. Buck-Regulator Switching Frequency vs RT_CLK Resistance

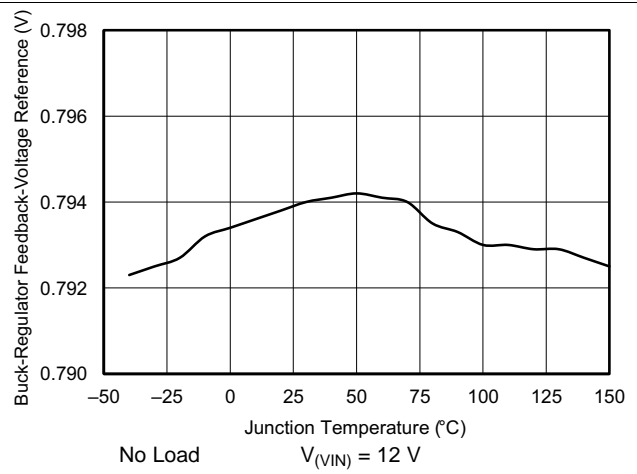

Figure 4. Buck-Regulator Feedback-Voltage Reference ($V_{(FB1)}$) vs Junction Temperature

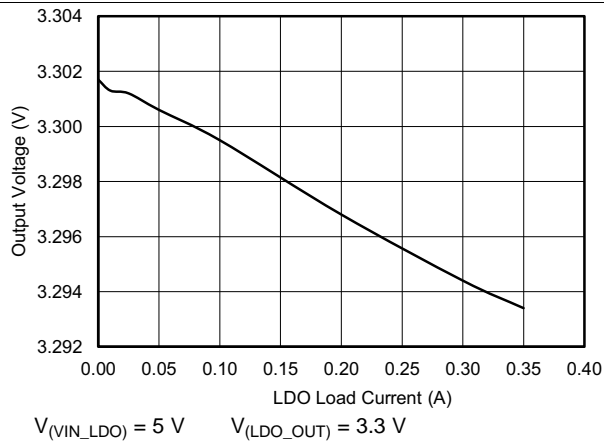

Figure 5. LDO-Regulator Load Regulation

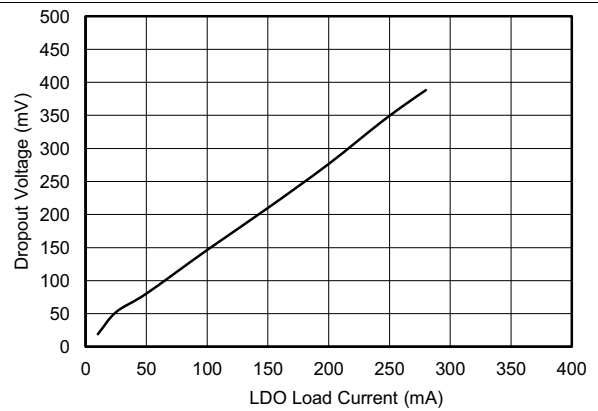

Figure 6. LDO-Regulator Dropout Voltage vs Load Current

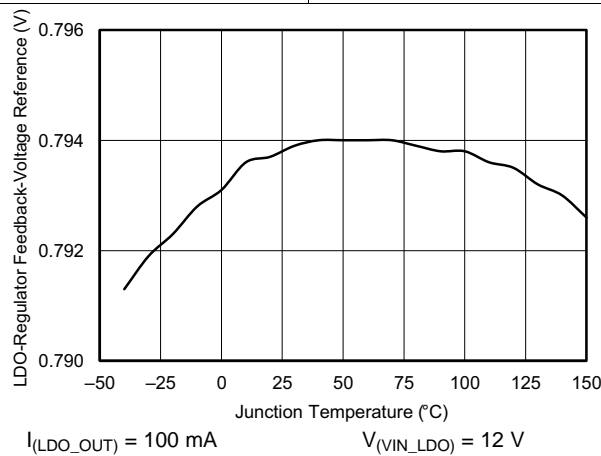

Figure 7. LDO-Regulator Feedback-Voltage Reference ($V_{(FB2)}$) vs Junction Temperature

7 Detailed Description

7.1 Overview

The TPS65320-Q1 buck regulator is a 40-V, 3.2-A, step-down (buck) converter with a 280-mA LDO linear regulator. Both regulators have low quiescent consumption during a light loads to prolong the battery life.

The buck converter improves performance during line and load transients by implementing a constant-frequency and current-mode control that reduces output capacitance, simplifying external frequency-compensation design. The wide switching frequency of 100 kHz to 2500 kHz allows for efficiency and size optimization when selecting the output-filter components. The switching frequency can be adjusted by using a resistor to ground on the RT/CLK pin. The buck converter has an internal phase-locked loop (PLL) on the RT/CLK pin that synchronizes the power switch turnon to the falling edge of an external system clock.

The TPS65320-Q1 buck regulator reduces the external component count by integrating the boot recharge diode. A capacitor between the BOOT and SW pins supplies the bias voltage for the integrated high-side MOSFET. The output voltage can be stepped down to as low as the 0.8-V reference. The soft-start feature minimizes inrush currents and provides power-supply sequencing during power up. Connect a small-value capacitor to the SS pin to adjust the soft-start time. Couple a resistor divider to the pin for critical power-supply sequencing requirements.

The LDO regulator only consumes about 40- μ A current in light loads. The LDO regulator can also track the battery when battery voltage is low (in a cold-crank condition). The input of the LDO regulator has a unique auto-source feature which sources the input supply from either the buck output or the battery. If both the buck and LDO regulators are enabled, the buck regulator switches the input of the LDO regulator to the output of the buck to reduce heat. With the buck disabled or the buck output voltage out of regulation (V_{FB1} less than 91% of V_{ref}), the buck regulator switches the LDO input automatically to the input voltage.

The LDO regulator of the TPS65320-Q1 device has a power-good comparator (nRST) that asserts when the regulated output voltage is less than 91% of the nominal output voltage.

7.2 Functional Block Diagram

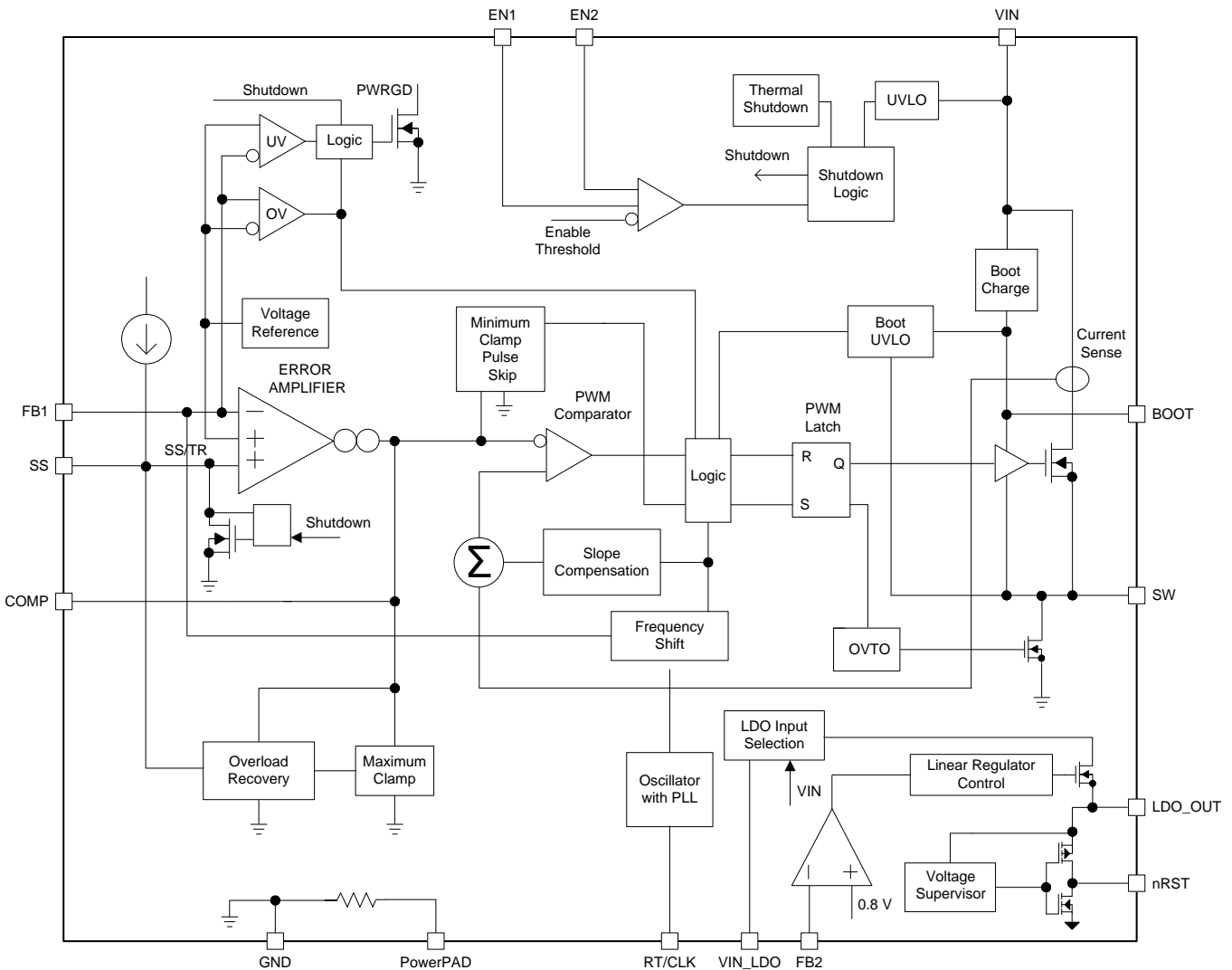

7.3 Feature Description

7.3.1 Buck Regulator

7.3.1.1 Fixed-Frequency PWM Control

The TPS65320-Q1 buck regulator uses an adjustable, fixed-frequency peak-current mode control. An internal voltage reference compares the output voltage through external resistors on the FB1 pin to an error amplifier which drives the COMP pin. An internal oscillator initiates the turnon of the high-side power switch. The buck regulator compares the error amplifier output to the high-side power-switch current. When the power-switch current reaches the level set by the COMP voltage, the power switch turns off. The COMP pin voltage increases and decreases as the output current increases and decreases. The buck regulator implements a current limit by clamping the COMP pin voltage to a maximum level.

7.3.1.2 Slope Compensation Output

The TPS65320-Q1 buck regulator adds a compensating ramp to the switch current signal. This slope compensation prevents sub-harmonic oscillations. The available peak-inductor current remains constant over the full duty-cycle range.

Feature Description (continued)

7.3.1.3 Pulse-Skip Eco-mode™ Control Scheme

The TPS65320-Q1 buck regulator operates in a pulse-skip mode at light load currents to improve efficiency by reducing switching and gate-drive losses. The design of the TPS65320-Q1 buck regulator is such that if the output voltage is within regulation and the peak switch current at the end of any switching cycle is below the pulse-skipping-current threshold, the buck regulator enters pulse-skip mode. This current threshold is the current level corresponding to a nominal COMP voltage, or 720 mV. The current at which entry to the pulse-skip mode occurs depends on switching frequency, inductor selection, output-capacitor selection, and compensation network.

In pulse-skip mode, the buck regulator clamps the COMP pin voltage at 720 mV, inhibiting the high-side MOSFET. Further decreases in load current or in output voltage cannot drive the COMP pin below this clamp-voltage level. Because the buck regulator is not switching, the output voltage begins to decay. As the voltage-control loop compensates for the falling output voltage, the COMP pin voltage begins to rise. At this time, the high-side MOSFET turns on and a switching pulse initiates on the next switching cycle. The peak current is set by the COMP pin voltage. The output current recharges the output capacitor to the nominal voltage, then the peak switch current begins to decrease, and eventually falls below the pulse-skip-mode threshold, at which time the buck regulator enters Eco-mode again.

For pulse-skip-mode operation, the TPS65320-Q1 buck regulator senses the peak current, not the average or load current. Therefore, the load current where the buck regulator enters pulse-skip mode is dependent on the output inductor value. When the load current is low and the output voltage is within regulation, the buck regulator enters a sleep mode and draws only 140- μ A input quiescent current. The internal PLL remains operating when the buck regulator is in sleep mode.

7.3.1.4 Dropout Operation and Bootstrap Voltage (BOOT)

The TPS65320-Q1 buck regulator has an integrated boot regulator and requires a small ceramic capacitor between the BOOT and SW pins to provide the gate-drive voltage for the high-side MOSFET. The BOOT capacitor recharges when the high-side MOSFET is off and the low-side diode conducts. The value of this ceramic capacitor should be 0.1 μ F. TI recommends a ceramic capacitor with an X7R or X5R grade dielectric and a voltage rating of 10 V or higher because of the stable characteristics over temperature and voltage.

To improve drop out, the high-side MOSFET of the TPS65320-Q1 buck regulator remains on for 7 consecutive switching cycles, and is forced off during the 8th switching cycle to allow the low-side diode to conduct and refresh the charge on the BOOT capacitor. Because the current supplied by the BOOT capacitor is low, the high-side of the MOSFET can remain on longer before it is required to refresh the BOOT capacitor.

Voltage drops across the power MOSFET, inductor resistance, low-side diode, and printed circuit board resistance are the main influence on the effective duty cycle during dropout of the regulator. During operating conditions in which the input voltage drops and the regulator is operating in continuous-conduction mode (CCM), the high-side MOSFET can remain on for 100% of the duty cycle to maintain output regulation until the BOOT to SW voltage falls below 2.1 V.

Careful attention must be given to maximum duty cycle applications that experience extended time periods with light loads or no load. When the voltage across the BOOT capacitor falls below the 2.1-V UVLO threshold, the high-side MOSFET turns off, however not-enough inductor current exists to pull the SW pin down to recharge the BOOT capacitor. The high-side MOSFET of the regulator stops switching because the voltage across the BOOT capacitor is less than 2.1 V. The output capacitor then decays until the difference in the input voltage and output voltage is greater than 2.1 V, which exceeds the BOOT UVLO threshold, and the buck regulator begins switching again until reaching the desired output voltage. This operating condition persists until the input voltage, the load current, or both increase.

7.3.1.5 Error Amplifier

The buck converter of the TPS65320-Q1 buck regulator has a transconductance amplifier acting as the error amplifier. The error amplifier compares the FB1 voltage to the lower of the internal soft-start (SS) voltage or the internal 0.8-V voltage reference. The transconductance (gm) of the error amplifier is 310 μ S during normal operation. During the soft-start operation, the transconductance is a fraction of the normal operating gm. When the voltage of the voltage on the FB1 pin is below 0.8 V and the buck regulator is regulating using an internal SS voltage, the gm is 70 μ S. For frequency compensation, external compensation components (capacitor with series resistor and an optional parallel capacitor) must be connected between the COMP pin and the GND pin.

Feature Description (continued)

7.3.1.6 Voltage Reference

The voltage reference system produces a precise $\pm 2\%$ voltage reference over temperature by scaling the output of a temperature-stable bandgap circuit.

7.3.1.7 Adjusting the Output Voltage

A resistor divider from the output node to the FB1 pin sets the output voltage. Using a divider resistor with a tolerance of 1% or better is recommended. Begin with a value of 10 k Ω for the R2 resistor and use [Equation 1](#) to calculate the value of R1. To improve efficiency at light loads, consider using larger-value resistors. If the values are too high, the regulator is more susceptible to noise and voltage errors from the FB1 input current are noticeable.

$$R1 = R2 \times \frac{V_O - 0.8 \text{ (V)}}{0.8 \text{ (V)}}$$

where

- V_O is the buck regulator output voltage (1)

7.3.1.8 Soft-Start and Tracking Pin (SS/TR)

The TPS65320-Q1 buck regulator effectively uses the lower voltage of the internal voltage reference or the SS/TR pin voltage as the reference voltage of the power supply and regulates the output accordingly. A capacitor on the SS/TR pin to ground implements a soft-start time. The TPS65320-Q1 buck regulator has an internal pullup-current source of 2 μA that charges the external soft-start capacitor. Use [Equation 2](#) to calculate to calculate the value of the soft-start capacitor, C_{SS} , which sets the soft-start time, t_{SS} (10% to 90%). The soft-start capacitor should remain lower than 0.47 μF and greater than 1 nF.

$$C_{SS} \text{ (nF)} = \frac{t_{SS} \text{ (ms)} \times I_{SS} \text{ (\mu A)}}{V_{ref} \text{ (V)} \times 0.8}$$

where

- The voltage reference (V_{ref}) is 0.8 V.
- The soft-start current (I_{SS}) is 2 μA (2)

At power up with the EN1 pin or after recovering from a UVLO event or from a thermal shutdown event, the TPS65320-Q1 buck regulator does not begin switching until the soft-start pin, SS/TR, discharges to less than 40 mV to ensure a proper power up.

7.3.1.9 Overload Recovery Circuit

The TPS65320-Q1 buck regulator has an overload recovery (OLR) circuit. The OLR circuit soft-starts the output from the overload voltage to the nominal regulation voltage on removal of the fault condition. The OLR circuit discharges the SS/TR pin to a voltage slightly greater than the FB1 pin voltage using an internal pulldown of 382 μA when the error amplifier changes to a high voltage from a fault condition. On removal of the fault condition, the output soft-starts from the fault voltage to the nominal output voltage.

7.3.1.10 Constant Switching Frequency and Timing Resistor (RT/CLK Pin)

The switching frequency of the TPS65320-Q1 buck regulator is adjustable over a wide range from approximately 100 kHz to 2500 kHz by placing a resistor on the RT/CLK pin. The RT/CLK pin voltage is typically 0.5 V and must have a resistor to ground to set the switching frequency. To determine the timing resistance for a given switching frequency, use [Equation 3](#) or the curves in [Figure 2](#). To reduce the solution size, the user typically sets the switching frequency as high as possible, but consider tradeoffs of the supply efficiency, maximum input voltage, and minimum controllable on-time. The minimum controllable on-time is typically 100 ns and limits the maximum operating input voltage. The frequency-shift circuit also limits the maximum switching frequency. The following sections discuss the maximum switching frequency in detail.

$$R_T \text{ (k}\Omega\text{)} = \frac{206033}{f_S \text{ (kHz)}^{1.0888}} \quad (3)$$

Feature Description (continued)

7.3.1.11 Overcurrent Protection and Frequency Shift

The TPS65320-Q1 buck regulator implements current mode control, which uses the COMP pin voltage to turn off the high-side MOSFET on a cycle-by-cycle basis. During each cycle, the switch current and COMP pin voltage are compared. When the peak switch current intersects the COMP voltage, the high-side switch turns off. During overcurrent conditions that pull the output voltage low, the error amplifier responds by driving the COMP pin high, increasing the switch current. Internal clamping of the error-amplifier output functions as a switch-current limit.

The TPS65320-Q1 buck regulator implements a frequency shift. The switching frequency is divided by 8, 4, 2, and 1 as the voltage ramps from 0 to 0.8 V on the FB1 pin. During short-circuit events (particularly with high-input-voltage applications), the control loop has a finite minimum controllable on-time, and the output has a low voltage. During the switch on-time, the inductor current ramps to the peak current limit because of the high input voltage and minimum on-time. During the switch off-time, the inductor would normally not have enough off time and output voltage for the inductor to ramp down by the ramp up amount. The frequency shift effectively increases the off-time, allowing the current to ramp down.

7.3.1.12 Selecting the Switching Frequency

The switching frequency that is selected should be the lower value of the two equations, [Equation 4](#) and [Equation 5](#). Use [Equation 4](#) to calculate the maximum switching frequency limitation set by the minimum controllable on-time. Setting the switching frequency above this value causes the regulator to skip switching pulses. The buck regulator maintains regulation, but pulse-skipping leads to high inductor current and a significant increase in output ripple voltage.

Use [Equation 5](#) to calculate the maximum switching frequency limit set by the frequency-shift protection. For adequate output short-circuit protection at high input voltages, set the switching frequency to a value less than the $f_{S(\text{maxshift})}$ frequency. In [Equation 5](#), to calculate the maximum switching frequency one must take into account that the output voltage decreases from the nominal voltage to 0 volts, and the f_{div} integer increases from 1 to 8 corresponding to the frequency shift.

In [Figure 8](#), the solid line illustrates a typical safe operating area regarding frequency shift and assumes the output voltage is zero volts, the resistance of the inductor is 0.130 Ω , the FET on-resistance is 0.127 Ω , and the diode voltage drop is 0.5 V. The dashed line is the maximum switching frequency to avoid pulse skipping.

$$f_{S(\text{max skip})} = \left(\frac{1}{t_{\text{ON}}} \right) \times \left(\frac{(I_L \times R_{\text{DC}} + V_O + V_d)}{(V_I - I_L \times R_{\text{HS}} + V_d)} \right)$$

where

- t_{ON} = controllable on-time (typ. 100 ns)
- I_L = inductor current
- R_{DC} = inductor resistance
- V_O = output voltage
- V_d = diode voltage drop
- V_I = maximum input voltage
- R_{HS} = FET on resistance (127 m Ω typical)

(4)

$$f_{S(\text{shift})} = \left(\frac{f_{\text{div}}}{t_{\text{ON}}} \right) \times \left(\frac{(I_L \times R_{\text{DC}} + V_{\text{O(SC)}} + V_d)}{(V_I - I_L \times R_{\text{HS}} + V_d)} \right)$$

where

- f_{div} = frequency divide factor (equals 8, 4, 2 or 1)
- $V_{\text{O(SC)}}$ = output voltage during short

(5)

Feature Description (continued)

7.3.1.14 Overvoltage Transient Protection

The TPS65320-Q1 buck regulator incorporates an overvoltage transient-protection (OVTP) circuit to minimize voltage overshoot when recovering from output fault conditions or strong unload transients on power-supply designs with low-value output capacitance. For example, with the power-supply output overloaded, the error amplifier compares the actual output voltage to the internal reference voltage. If the FB1 pin voltage is lower than the internal reference voltage for a considerable time, the output of the error amplifier responds by clamping the error amplifier output to a high voltage, thus requesting the maximum output current. On removal of the condition, the regulator output rises and the error-amplifier output transitions to the steady-state duty cycle. In some applications, the power-supply output voltage can respond faster than the error-amplifier output can respond which actually leads to the possibility of an output overshoot. The OVTP feature minimizes the output overshoot when using a low-value output capacitor by implementing a circuit to compare the FB1 pin voltage to the OVTP threshold (which is 109% of the internal voltage reference). The FB1 pin voltage going higher than the OVTP threshold disables the high-side MOSFET, preventing current from flowing to the output and minimizing output overshoot. The FB1 voltage dropping lower than the OVTP threshold allows the high-side MOSFET to turn on at the next clock cycle.

7.3.1.15 Thermal Shutdown

The buck regulator implements an internal thermal shutdown to protect the regulator if the junction temperature exceeds 155°C (typical). The thermal shutdown forces the buck regulator to stop switching when the junction temperature exceeds the thermal trip threshold. When the junction temperature decreases below 145°C (typical), the buck regulator reinitiates the power-up sequence.

7.3.1.16 Small-Signal Model for Loop Response

Figure 10 shows an equivalent model for the TPS65320-Q1 control loop which can be modeled in a circuit-simulation program to check frequency response and dynamic load response. The error amplifier is a transconductance amplifier with a $g_{m_{ea}}$ of $\mu\text{A/V}$. One can model the error amplifier using an ideal voltage-controlled current source. Resistor R_o and capacitor C_o model the open-loop gain and frequency response of the amplifier. The 1-mV AC voltage source between nodes a and b effectively breaks the control loop for the frequency-response measurements. Plotting c versus a shows the small signal response of the frequency compensation. Plotting a versus b shows the small signal response of the overall loop. Check the dynamic loop response by replacing R_L with a current source that has the appropriate load-step amplitude and step rate in a time-domain analysis. This equivalent model is only valid for continuous-conduction-mode designs.

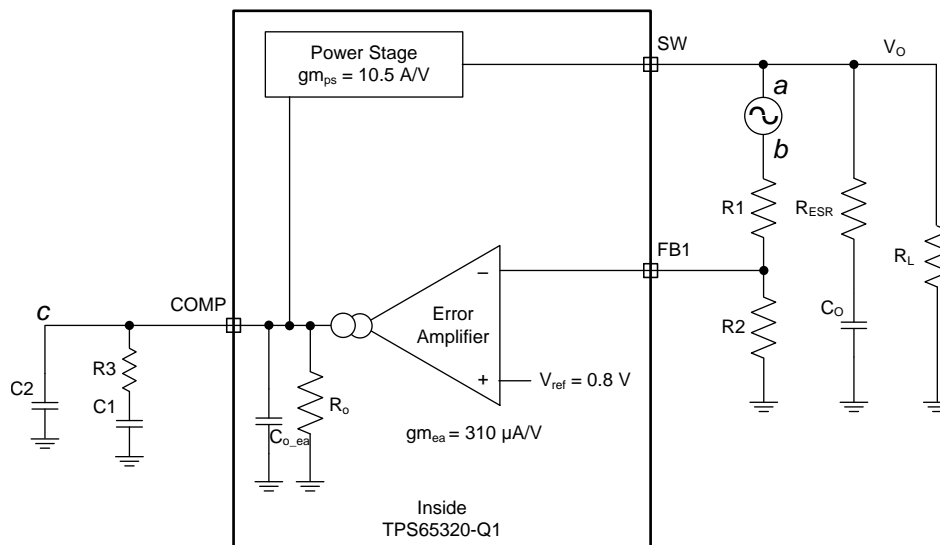

Figure 10. Small-Signal Model for Loop Response

Feature Description (continued)

7.3.1.17 Simple Small-Signal Model for Peak-Current Mode Control

Figure 11 shows a simple small-signal model that can be used to understand how to design the frequency compensation. A voltage-controlled current source (duty cycle modulator) supplying current to the output capacitor and load resistor can approximate the buck-regulator power stage. Equation 6 shows the control-to-output transfer function, which consists of a DC gain, one dominant pole, and one ESR zero. The quotient of the change in switch current divided by the change in COMP pin voltage (node c in Figure 10) is the power-stage transconductance. The gm_{ps} for the buck-regulator power stage buck regulator is 10.5 A/V. Use Equation 7 to calculate the low-frequency gain of the power stage which is the product of the transconductance and the load resistance.

As the load current increases and decreases, the low-frequency gain decreases and increases, respectively. This variation with the load may seem problematic at first, but the dominant pole moves with the load current (see Equation 8). The dashed line in the right half of Figure 11 highlights the combined effect. As the load current decreases, the gain increases and the pole frequency lowers, keeping the 0-dB crossover frequency the same for the varying load conditions, which makes designing the frequency compensation easier. The type of selected output capacitor determines whether the ESR zero has a profound effect on the frequency compensation design. Using high-ESR aluminum electrolytic capacitors can reduce the number of frequency-compensation components required to stabilize the overall loop because the phase margin increases from the ESR zero at the lower frequencies (see Equation 9).

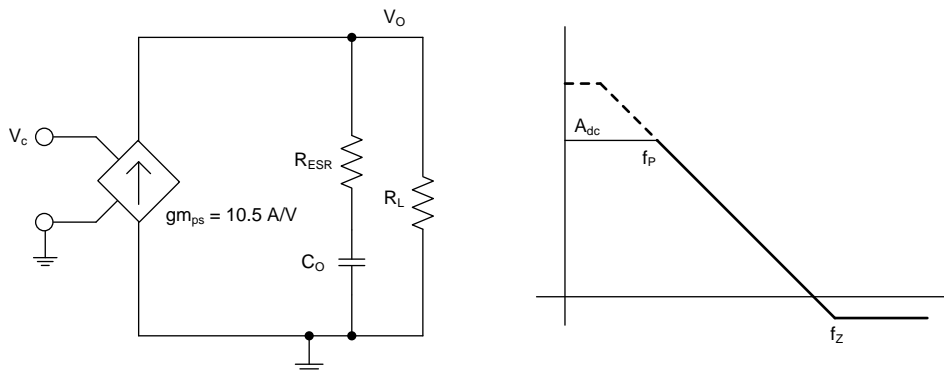

Figure 11. Simple Small-Signal Model and Frequency Response for Peak-Current Mode

$$\frac{V_O}{V_C} = A_{dc} \times \left(\frac{1 + \frac{s}{2\pi \times f_z}}{1 + \frac{s}{2\pi \times f_p}} \right) \quad (6)$$

$$A_{dc} = gm_{ps} \times R_L \quad (7)$$

$$f_{p_mod} = \frac{1}{2\pi \times R_L \times C_{OUT}} \quad (8)$$

$$f_{z_mod} = \frac{1}{2\pi \times R_{ESR} \times C_{OUT}} \quad (9)$$

7.3.1.18 Small-Signal Model for Frequency Compensation

The buck regulator of the TPS65320-Q1 device uses a transconductance amplifier for the error amplifier. Figure 12 shows compensation circuits. Implementation of Type 2 circuits is most likely in high-bandwidth power-supply designs. The purpose of loop compensation is to ensure stable operation while maximizing dynamic performance. Use of the Type 1 circuit is with power-supply designs that have high-ESR aluminum electrolytic or tantalum capacitors. Equation 10 and Equation 11 show how to relate the frequency response of the amplifier to

Feature Description (continued)

the small-signal model in [Figure 12](#). Modeling of the open-loop gain and bandwidth uses the R_o and C_o shown in [Figure 12](#). See the [Typical Applications](#) section for a design example with a Type 2A network that has a low-ESR output capacitor. For stability purposes, the target is to have a loop-gain slope that is -20 dB/decade at the crossover frequency. Also, the crossover frequency should not exceed one-fifth of the switching frequency (120 kHz in the case of a 600-kHz switching frequency).

For dynamic purposes, the higher the bandwidth, the faster the load-transient response. A large DC gain means high DC regulation accuracy (DC voltage changes little with load or line variations). To achieve this loop gain, set the compensation components according to the shape of the control-output bode plot.

[Equation 10](#) through [Equation 20](#) serve as a reference to calculate the compensation components. R_o and C_1 form the dominant pole (P1). A resistor (R_3) and a capacitor (C_1) in series to ground work as zero (Z1). In addition, for an optional pole, add a lower-value capacitor (C_2) in parallel with R_3 to. This capacitor can be used to filter noise at switching frequency, and it is also needed if the output capacitor has high ESR.

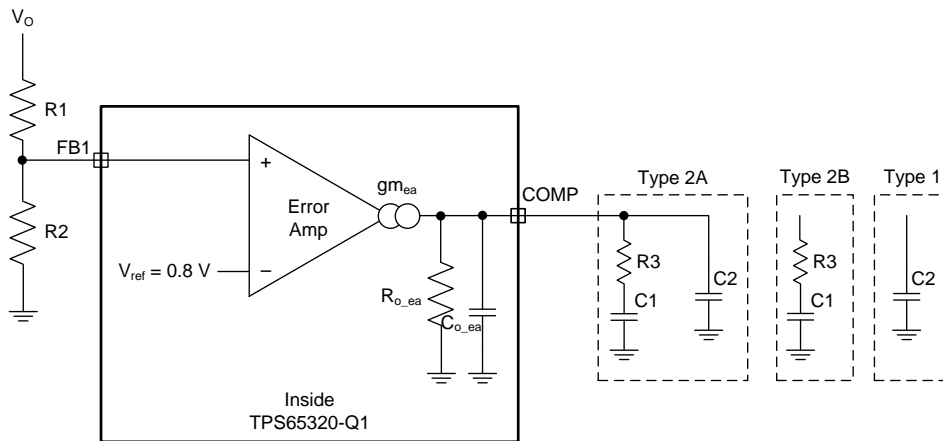

Figure 12. Types of Frequency Compensation

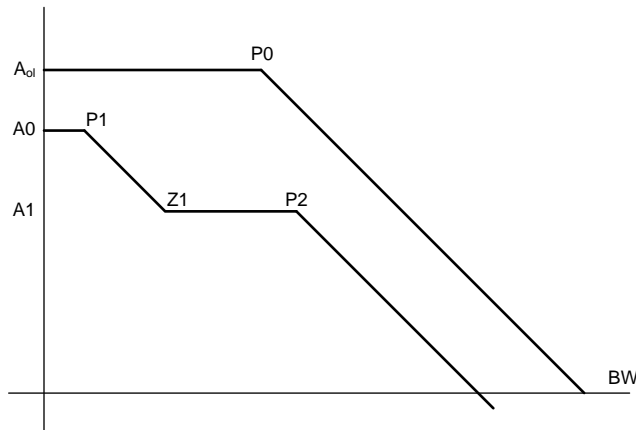

Figure 13. Frequency Response of the Type 2 Frequency Compensation

$$R_{o_ea} = \frac{A_{ol} (V/V)}{g_{m_ea}} \tag{10}$$

$$C_{o_ea} = \frac{g_{m_ea}}{2\pi \times BW (Hz)} \tag{11}$$

$$P0 = \frac{1}{2\pi \times R_{o_ea} \times C_{o_ea}} \tag{12}$$

Feature Description (continued)

$$EA = A0 \times \frac{\left(1 + \frac{2}{2\pi \times f_{Z1}}\right)}{\left(1 + \frac{2}{2\pi \times f_{P1}}\right) \times \left(1 + \frac{2}{2\pi \times f_{P2}}\right)} \quad (13)$$

$$A0 = gm_{ea} \times R_{o_ea} \times \frac{R2}{R1 + R2} \quad (14)$$

$$A1 = gm_{ea} \times R_{o_ea} \parallel R3 \times \frac{R2}{R1 + R2} \quad (15)$$

$$P1 = \frac{1}{2\pi \times R_{o_ea} \times C1} \quad (16)$$

$$Z1 = \frac{1}{2\pi \times R3 \times C1} \quad (17)$$

$$P2 = \frac{1}{2\pi \times R3 \times C2} \quad \text{Type 2A} \quad (18)$$

$$P2 = \frac{1}{2\pi \times R3 \times C_{o_ea}} \quad \text{Type 2B} \quad (19)$$

$$P2 = \frac{1}{2\pi \times R_{o_ea} \times C2} \quad \text{Type 1} \quad (20)$$

7.3.2 LDO Regulator

For the TPS65320-Q1 device, the design of the linear regulator is for low-power consumption and a quiescent current of about 40 μ A in light-load applications.

The LDO regulator requires both supplies from VIN and VIN_LDO to function. At all times the voltage level of VIN must be higher or equal to the voltage level of VIN_LIN for the the LDO regulator to function properly. The current capability of the LDO regulator is 280 mA under the full VIN_LDO input range, while VIN \geq 4 V. When VIN becomes less than 4 V, the current capability of the LDO regulator decreases.

7.3.2.1 Charge-Pump Operation

The LDO regulator has an internal charge pump which turns on or off depending on the input voltage. The charge-pump switching circuitry does not cause conducted emissions to exceed required thresholds on the input voltage line. The charge-pump switching thresholds are hysteretic. Figure 14 shows the typical switching thresholds for the charge pump.

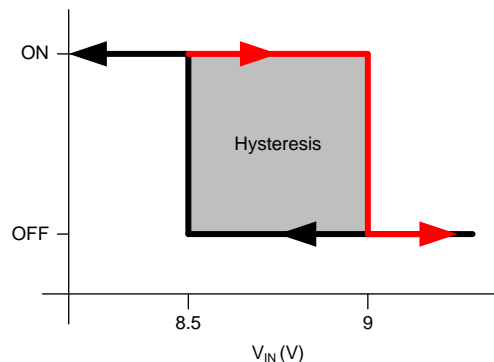

Figure 14. Charge-Pump Switching Thresholds

Feature Description (continued)
Table 1. Typical Quiescent Current Consumption

	CHARGE PUMP ON	CHARGE PUMP OFF
LDO I_q	300 μ A	40 μ A

7.3.2.2 Low-Voltage Tracking

At low input voltages, the regulator drops out of regulation, and the output voltage tracks input minus a dropout voltage (V_{DROPOUT}). This feature allows for a smaller input capacitor and can possibly eliminate the requirement for a boost convertor during cold-crank conditions.

7.3.2.3 Power-Good Output, nRST

The nRST pin is a push-pull output formed by a push-pull stage between LDO_OUT and GND pins. The power-on-reset output asserts low until the output voltage on LDO_OUT exceeds the setting thresholds (91%) and the deglitch timer has expired. Additionally, whenever the EN2 pin is low or open, the nRST pin immediately asserts low regardless of the output voltage. If a thermal shutdown occurs because of excessive thermal conditions, this pin also asserts low. When the nRST is released (not asserted low), it can only be pulled-up to the specified V_{OH} voltage when the LDO_OUT voltage is equal to or higher than 3.3 V.

7.3.3 Enable and Undervoltage Lockout

The TPS65320-Q1 device enable pins (EN1 and EN2) are high-voltage-tolerant input pins with an internal pulldown circuit. A high input activates the buck regulator and turns the regulators ON.

The TPS65320-Q1 device has an internal UVLO circuit to shut down the output if the input voltage falls below an internally fixed UVLO threshold level. This UVLO circuit ensures that both regulators are not latched into an unknown state during low-input-voltage conditions. The regulators power up when the input voltage exceeds the voltage level.

7.4 Device Functional Modes

7.4.1 Modes of Operation

The buck regulator has two hardware enable pins, and one can turn off either the buck or the LDO by pulling the enable pin low, as listed in Table 2. One unique feature of the TPS65320-Q1 buck regulator is the input auto source of the LDO. With both the buck and the LDO enabled, the LDO receives input from the output of the buck through the VIN_LDO pin. In this mode, the buck output voltage must be higher than the LDO output voltage. With the buck disabled and the LDO still enabled, the input of the LDO changes automatically from VIN_LDO to VIN which is useful for standby operations which need a very low standby current, such as automotive infotainment, telematics, and other operations. The LDO changes the input when the buck output voltage is out of regulation ($V_{(FB1)}$ is less than 91% of V_{ref1}).

Table 2. Device Operation Modes

BUCK EN1	LDO EN2	DESCRIPTION
0	0	Both buck and LDO disabled
0	1	Buck disabled. LDO enabled and LDO input source is from the battery.
1	0	Buck enabled and LDO disabled
1	1	Both buck and LDO enabled and LDO input source is from buck output. Buck output voltage must be higher than LDO output voltage.

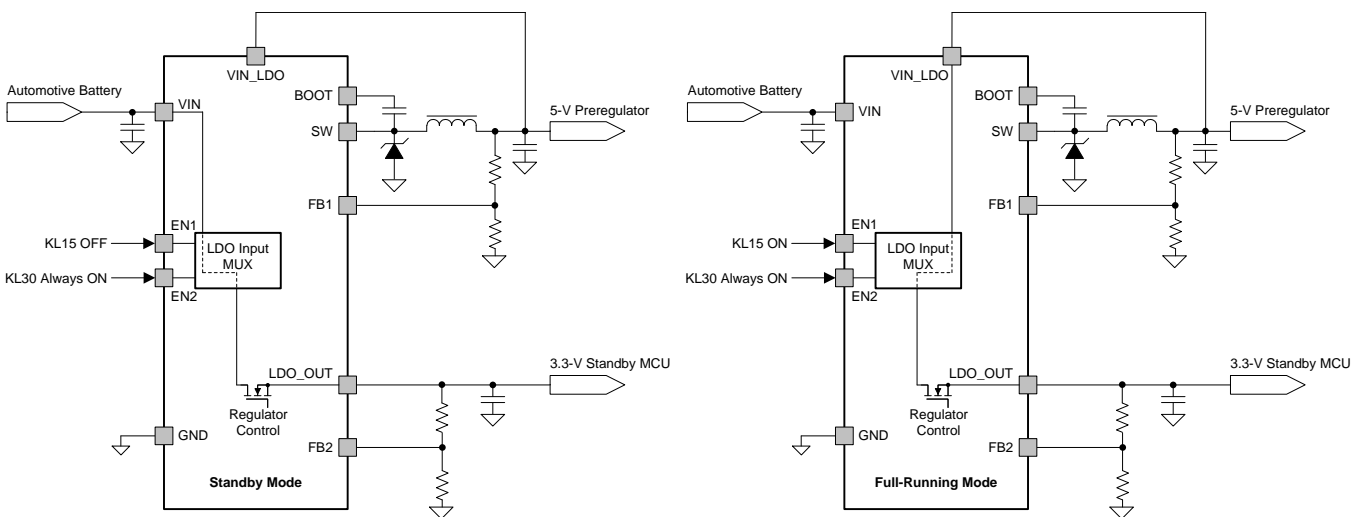

Figure 15. Example of LDO Auto Source in Standby Condition

8 Application and Implementation

NOTE

Information in the following applications sections is not part of the TI component specification, and TI does not warrant its accuracy or completeness. TI's customers are responsible for determining suitability of components for their purposes. Customers should validate and test their design implementation to confirm system functionality.

8.1 Application Information

The TPS65320-Q1 buck regulator operates with a supply voltage V_I of 3.6 V to 40 V. The TPS65320-Q1 LDO regulator operates with a supply voltage V_{IN_LDO} of 3 V to 40 V. For reducing power dissipation, TI strongly recommends to use the output voltage of the buck regulator as the input supply for the LDO regulator. To use the output voltage of the buck regulator this way, the selected buck-regulator output voltage must be higher than the selected LDO-regulator output voltage.

For optimized switching performance (such as low jitter) in automotive applications with input voltages that have wide ranges, TI recommends to operate the device at higher frequencies, such as 2 MHz, which also helps achieve AM-band compliance requirements (that extends until 1.7 MHz).

8.2 Typical Applications

8.2.1 2.2-MHz Switching Frequency, 9-V to 16-V Input, 5-V Output Buck Regulator, 3.3-V Output LDO Regulator

This example application details the design of a high-frequency switching regulator and linear regulator using ceramic output capacitors (see the [Detailed Design Procedure](#) section for the design procedure).

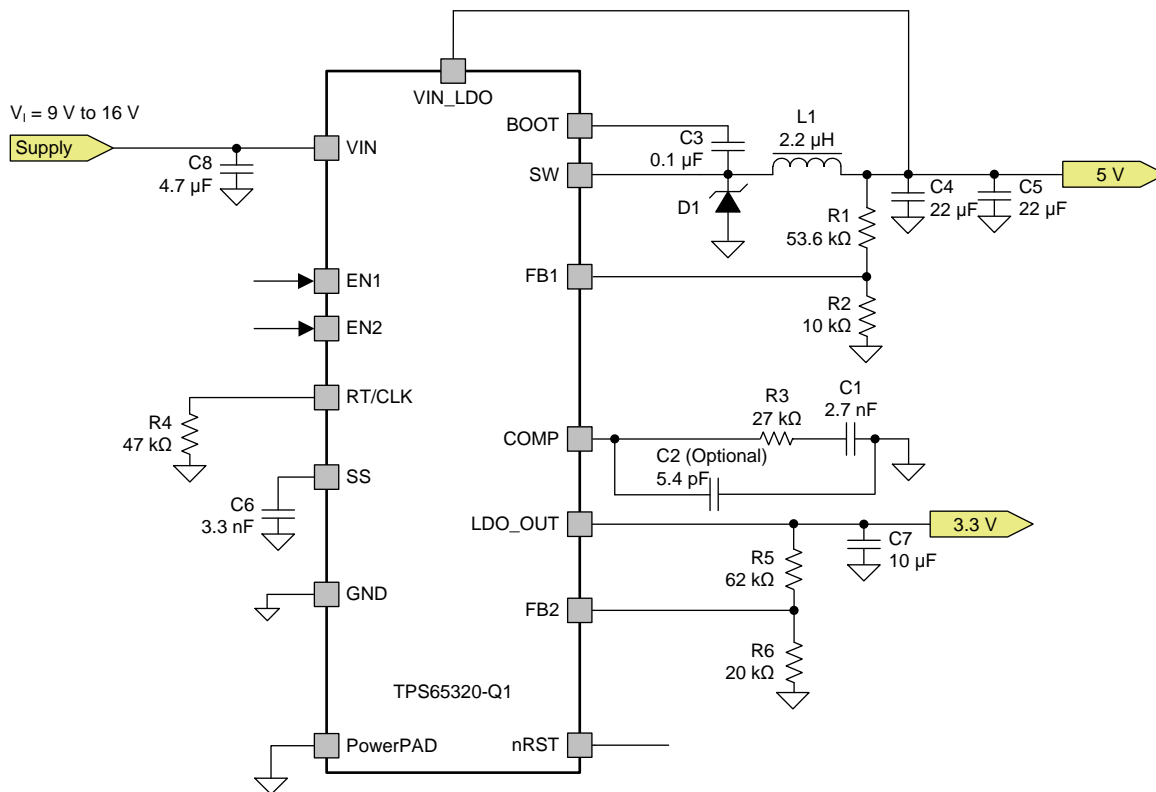

Figure 16. TPS65320-Q1 Design Example With 2.2-MHz Switching Frequency

Typical Applications (continued)

8.2.1.1 Design Requirements

A few parameters must be known to begin the design process. Determination of these parameters is typically at the system level. This example begins with the parameters listed in [Table 3](#).

Table 3. Design Requirements

DESIGN PARAMETER	EXAMPLE VALUE
Input voltage, VIN1	9 V to 16 V, typical 12 V
Output voltage, VREG1 (buck regulator)	5 V ± 2%
Maximum output current I _{O_max1}	3 A
Minimum output current I _{O_min1}	0.01 A
Transient response 0.01 A to 0.8 A	3%
Output ripple voltage	1%
Switching frequency f _{SW}	2.2 MHz
Output voltage, VREG2 (LDO regulator)	3.3 V ± 2%

8.2.1.2 Detailed Design Procedure

8.2.1.2.1 Switching Frequency Selection for the Buck Regulator

The first step is to decide on a switching frequency for the regulator. Typically, the user selects the highest switching frequency possible because this produces the smallest solution size. The high switching frequency allows for lower-valued inductors and smaller output capacitors compared to a power supply that switches at a lower frequency. The selectable switching frequency is limited by the minimum on-time of the internal power switch, the input voltage, the output voltage, and the frequency-shift limitation.

Consider minimum on-time and frequency-shift protection as calculated with [Equation 4](#) and [Equation 5](#). To find the maximum switching frequency for the regulator, select the lower value of the two results. Switching frequencies higher than these values result in pulse skipping or the lack of overcurrent protection during a short circuit. The typical minimum on-time, t_{ON-min}, is 100 ns for the TPS65320-Q1 device. For this example, where the output voltage is 5 V and the maximum input voltage is 16 V, use a switching frequency of 2200 kHz. Use [Equation 3](#) to calculate the timing resistance for a given switching frequency. The R4 resistor sets the switching frequency. A 2.2-MHz switching frequency requires a 47-kΩ resistor (see R4 in [Figure 16](#)).

8.2.1.2.2 Output Inductor Selection for the Buck Regulator

Use [Equation 21](#) to calculate the minimum value of the output inductor. The output capacitor filters the inductor ripple current. Therefore, selecting high inductor-ripple currents impacts the selection of the output capacitor because the output capacitor must have a ripple-current rating equal to or greater than the inductor ripple current. In general, the inductor ripple value is at the discretion of the designer; however, the following guidelines can be used to select this value. K_{IND} is a coefficient that represents the amount of inductor ripple current relative to the maximum output current.

$$L_O \text{ min} = \frac{V_I \text{ max} - V_O}{I_O \times K_{IND}} \times \frac{V_O}{V_I \text{ max} \times f_S} \quad (21)$$

For designs using low-ESR output capacitors such as ceramics, use a value as high as K_{IND} = 0.3. When using higher-ESR output capacitors, K_{IND} = 0.2 yields better results. In a wide-input voltage regulator, selecting an inductor ripple current on the larger side is best because it allows the inductor to still have a measurable ripple current with the input voltage at a minimum.

For this design example, use $K_{IND} = 0.3$ and the minimum inductor value which is calculated as $1.73 \mu\text{H}$. For this design, select the nearest standard value which is $2.2 \mu\text{H}$ (see L1 in [Figure 16](#)). Use [Equation 22](#) to calculate the inductor ripple current (I_{ripple}). For the output filter inductor, do not to exceed the RMS-current and saturation-current ratings. Use [Equation 23](#) and [Equation 24](#) to calculate the RMS current ($I_{L\text{-RMS}}$) and the peak inductor ($I_{L\text{-peak}}$).

$$I_{\text{ripple}} = \frac{V_O \times (V_{I\text{max}} - V_O)}{V_{I\text{max}} \times L_O \times f_S} \quad (22)$$

$$I_{L\text{-RMS}} = \sqrt{I_O^2 + \frac{1}{12} I_{\text{ripple}}^2} \quad (23)$$

$$I_{L\text{-peak}} = I_O + \frac{I_{\text{ripple}}}{2} \quad (24)$$

For this design, the RMS inductor current is 3.01 A, the peak inductor current is 3.36 A, and the inductor ripple current is 0.71 A. The selected inductor is a Coilcraft MSS1038-103NLB and has a saturation-current rating of 4.52 A and an RMS-current rating of 4.05 A. As the equation set demonstrates, lower ripple current reduces the output ripple voltage of the buck regulator but requires a larger value of inductance. Selecting higher ripple currents increases the output ripple voltage of the buck regulator but allows for a lower inductance value.

8.2.1.2.3 Output Capacitor Selection for the Buck Regulator

Consider three primary factors when selecting the value of the output capacitor. The output capacitor determines the modulator pole, the output ripple voltage, and how the buck regulator responds to a large change in load current. Select the output capacitance based on the most stringent of these three criteria. The desired response to a large change in the load current is the first criterion. The output capacitor must supply the load with current when the regulator cannot. This situation occurs if the desired hold-up times are present for the buck regulator. In this case, the output capacitor must hold the output voltage above a certain level for a specified amount of time after the input power is removed. The regulator is also temporarily unable to supply sufficient output current if a large, fast increase occurs affecting the current requirements of the load, such as a transition from no load to full load. The buck regulator usually requires two or more clock cycles for the control loop to notice the change in load current and output voltage, and to adjust the duty cycle to react to the change. Size the output capacitor to supply the extra current to the load until the control loop responds to the load change. The output capacitance must be large enough to supply the difference in current for two clock cycles while only allowing a tolerable amount of droop in the output voltage. Use [Equation 25](#) to calculate the minimum output capacitance required to supply the difference in current.

$$C_O > \frac{2 \times \Delta I_O}{f_S \times \Delta V_O}$$

where

- ΔI_O is the change in the buck-regulator output current
 - f_S is the switching frequency of the buck regulator
 - ΔV_O is the allowable change in the buck-regulator output voltage
- (25)

For this example, the specified transient load response is a 3% change in V_O for a load step from 0.01 A to 0.8 A (full load). For this example, $\Delta I_O = 0.8 - 0.01 = 0.79 \text{ A}$ and $\Delta V_O = 0.03 \times 5 = 0.15 \text{ V}$. Using these numbers results in a minimum capacitance of $4.7 \mu\text{F}$. This value does not consider the ESR of the output capacitor in the output voltage change. For ceramic capacitors, the ESR is usually small enough to ignore in this calculation. Aluminum electrolytic and tantalum capacitors have higher ESR that must be take into consideration.

The catch diode of the regulator cannot sink current. Therefore any stored energy in the inductor produces an output-voltage overshoot when the load current rapidly decreases. Also, size the output capacitor to absorb the energy stored in the inductor when transitioning from a high load current to a lower load current. The excess energy that is stored in the output capacitor increases the voltage on the capacitor. Size the capacitor to maintain the desired output voltage during these transient periods.

Use [Equation 26](#) to calculate the minimum capacitance to keep the output voltage overshoot to a desired value.

$$C_O > L_O \times \frac{(I_{OH}^2 - I_{OL}^2)}{(V_f^2 - V_i^2)}$$

where

- L_O is the output inductance of the buck regulator
 - I_{OH} is the output current of the buck regulator under heavy load
 - I_{OL} is the output current of the buck regulator under light load
 - V_f is the final peak output voltage of the buck regulator
 - V_i is the initial capacitor voltage of the buck regulator
- (26)

For this example, the worst-case load step is from 3 A to 0.01 A. The output voltage increases during this load transition, and the stated maximum in the specification is 3% of the output voltage (see the [Electrical Characteristics](#) table). This makes $V_f = 1.03 \times 5 = 5.15$. V_i is the initial capacitor voltage, which is the nominal output voltage of 5 V. Using these numbers in [Equation 26](#) yields a minimum capacitance of 13 μ F.

[Equation 27](#) calculates the minimum output capacitance needed to meet the output ripple-voltage specification. [Equation 27](#) yields 0.8 μ F.

$$C_O > \frac{1}{8 \times f_S} \times \frac{1}{\frac{V_{O-ripple}}{I_{L-ripple}}}$$

where

- $V_{O-ripple}$ is the maximum allowable output ripple voltage of the buck regulator
 - $I_{L-ripple}$ is the inductor ripple current of the buck regulator
- (27)

Use [Equation 28](#) to calculate the maximum ESR required for the output capacitor to meet the output voltage ripple specification. As a result of [Equation 28](#), the ESR should be less than 70 m Ω .

$$R_{ESR} < \frac{V_{O-ripple}}{I_{L-ripple}}$$
(28)

The most stringent criterion for the output capacitor is 13 μ F of capacitance to keep the output voltage in regulation during a load transient.

Factor in additional capacitance deratings for aging, temperature, and DC bias which increase this minimum value. For this example, two 22- μ F, 10-V ceramic capacitors with 3 m Ω of ESR are used (see C4 and C5 in [Figure 16](#)). Capacitors generally have limits to the amount of ripple current they can handle without failing or producing excess heat. Specify an output capacitor that can support the inductor ripple current. Some capacitor data sheets specify the root-mean-square (RMS) value of the maximum ripple current.

Use [Equation 29](#) to calculate the RMS ripple current that the output capacitor must support. For this application, [Equation 29](#) yields 205 mA.

$$I_{CO(RMS)} < \frac{V_O \times (V_{I\max} - V_O)}{\sqrt{12} \times V_{I\max} \times L_O \times f_S}$$
(29)

8.2.1.2.4 Catch Diode Selection for the Buck Regulator

The TPS65320-Q1 device requires an external catch diode between the SW pin and GND (see D1 in [Figure 16](#)). The selected diode must have a reverse voltage rating equal to or greater than $V_{I\max}$. The peak current rating of the diode must be greater than the maximum inductor current. The diode should also have a low forward voltage. Schottky diodes are typically a good choice for the catch diode because of low forward voltage of these diodes. The lower the forward voltage of the diode, the higher the efficiency of the regulator.

Typically, the higher the voltage and current ratings the diode has, the higher the forward voltage is. Although the design example has an input voltage up to 16 V, select a diode with a minimum of 40-V reverse voltage to allow input voltage transients up to the rated voltage of the TPS65320-Q1 device.

For the example design, the selection of a Schottky diode is B540C-13-F based on the lower forward voltage of this diode. This diode is also available in a larger package size, which has good thermal characteristics over small buck regulators. The typical forward voltage of the B540C-13-F is 0.55 V.

Also, select a diode with an appropriate power rating. The diode conducts the output current during the off-time of the internal power switch. The off-time of the internal switch is a function of the maximum input voltage, the output voltage, and the switching frequency. The output current during the off-time, multiplied by the forward voltage of the diode, equals the conduction losses of the diode. At higher switching frequencies, consider the AC losses of the diode. The AC losses of the diode are because the charging and discharging of the junction capacitance and reverse recovery.

8.2.1.2.5 Input Capacitor Selection for the Buck Regulator

The TPS65320-Q1 device requires a high-quality ceramic input decoupling capacitor (type X5R or X7R) of at least 3 μF of effective capacitance, and in some applications a bulk capacitance. The effective capacitance includes any DC bias effects. The voltage rating of the input capacitor must be greater than the maximum input voltage. The capacitor must also have a ripple-current rating greater than the maximum input-current ripple of the TPS65320-Q1 device. Use [Equation 30](#) to calculate the input ripple current ($I_{C1(\text{RMS})}$).

The value of a ceramic capacitor varies significantly over temperature and the amount of DC bias applied to the capacitor. Minimize the capacitance variations because of temperature by selecting a dielectric material that is stable over temperature. Designers usually select X5R and X7R ceramic dielectrics for power regulator capacitors because these capacitors have a high capacitance-to-volume ratio and are fairly stable over temperature. Also, select the output capacitor with the DC bias taken into consideration. The capacitance value of a capacitor decreases as the DC bias across a capacitor increases.

This design requires a ceramic capacitor with at least a 40-V voltage rating to support the maximum input voltage. Common standard ceramic capacitor voltage ratings include 4 V, 6.3 V, 10 V, 16 V, 25 V, 50 V, or 100 V. For this design example. The selection for this example is a 4.7- μF , 50-V capacitor (see C8 in [Figure 16](#)).

$$I_{C1(\text{RMS})} = I_{O \text{ max}} \times \sqrt{\frac{V_O}{V_{I \text{ min}}} \times \frac{(V_{I \text{ min}} - V_O)}{V_{I \text{ min}}}} \quad (30)$$

[Table 4](#) lists a selection of high-voltage capacitors. The input-capacitance value determines the input ripple voltage of the regulator. Use [Equation 31](#) to calculate the input ripple voltage (ΔV_I).

$$\Delta V_I = \frac{I_{O \text{ max}} \times 0.25}{C_1 \times f_S} \quad (31)$$

Using the design example values, $I_{O \text{ max}} = 3 \text{ A}$, $C_1 = 4.7 \mu\text{F}$, $f_S = 2200 \text{ kHz}$, yields an input ripple voltage of 72.5 mV and an RMS input ripple current of 1.49 A.

Table 4. Capacitor Types

VENDOR	VALUE (μF)	EIA Size	VOLTAGE	DIALECTRIC	COMMENTS
Murata	1 to 2.2	1210	100 V	X7R	GRM32 series
	1 to 4.7		50 V		
	1	1206	100 V		GRM31 series
	1 to 2.2		50 V		
AVX	1 to 4.7	1210	50 V		X7R dielectric series
	1		100 V		
	1 to 4.7	1812	50 V		
	1 to 2.2		100 V		

8.2.1.2.6 Soft-Start Capacitor Selection for the Buck Regulator

The soft-start capacitor determines the minimum amount of time required for the output voltage to reach the nominal programmed value during power up which is useful if a load requires a controlled-voltage slew rate. This feature is also useful if the output capacitance is large and requires large amounts of current to charge the capacitor quickly to the output voltage level. The large currents required to charge the capacitor may make the TPS65320-Q1 device reach the current limit, or excessive current draw from the input power supply may cause the input voltage rail to sag. Limiting the output voltage-slew rate solves both of these problems.

The soft-start time must be long enough to allow the regulator to charge the output capacitor up to the output voltage without drawing excessive current. Use [Equation 32](#) to calculate the minimum soft-start time, t_{ss} , required to charge the output capacitor, C_O , from 10% to 90% of the output voltage, V_O , with an average soft-start current of $I_{ss(avg)}$.

$$t_{ss} > \frac{C_O \times V_O \times 0.8}{I_{ss(avg)}} \quad (32)$$

In the example, to charge the effective output capacitance of 44 μF up to 5 V while only allowing the average output current to be 3 A requires a 0.088-ms soft-start time.

When the soft-start time is known, use [Equation 2](#) to calculate the soft-start capacitor. For the example circuit, the soft-start time is not too critical because the output-capacitor value is $2 \times 22 \mu\text{F}$, which does not require much current to charge to 5 V. The example circuit has the soft-start time set to an arbitrary value of 1 ms, which requires a 3.125-nF soft-start capacitor. This design uses the next-larger standard value of 3.3 nF.

8.2.1.2.7 Bootstrap Capacitor Selection for the Buck Regulator

Connect a 0.1- μF ceramic capacitor between the BOOT and SW pins for proper operation. TI recommends using a ceramic capacitor with X5R or better-grade dielectric. The capacitor should have a 10-V or higher voltage rating.

8.2.1.2.8 Output Voltage and Feedback Resistor Selection for the Buck Regulator

The voltage divider of R1 and R2 sets the output voltage. For the design example, the selected value of R2 is 10 k Ω , and the calculated value of R1 is 53.6 k Ω . Because of current leakage of the FB1 pin, the current flowing through the feedback network should be greater than 1 μA to maintain the output-voltage accuracy. Selecting higher resistor values decreases the quiescent current and improves efficiency at low output currents, but can introduce noise immunity problems.

8.2.1.2.9 Frequency Compensation Selection for the Buck Regulator

Several possible methods exist to design closed loop compensation for DC-DC converters. The method presented here is easy to calculate and ignores the effects of the slope compensation that is internal to the buck regulator. Ignoring the slope compensation usually causes the actual crossover frequency to be lower than the crossover frequency used in the calculations. This method assumes the crossover frequency is between the modulator pole and the ESR zero, and that the ESR zero is at least 10 times greater than the modulator pole.

To begin, use [Equation 33](#) to calculate the modulator pole, f_{P_mod} , and [Equation 34](#) to calculate the ESR zero, f_{Z_mod} . For C_{OUT} , use a derated value of 40 μF .

$$f_{P_mod} = \frac{1}{2\pi \times R_L \times C_O} = \frac{I_{max}}{2\pi \times V_O \times C_O} \quad (33)$$

$$f_{Z_mod} = \frac{1}{2\pi \times R_{ESR} \times C_O} \quad (34)$$

Use [Equation 35](#) and [Equation 36](#) to calculate an estimate starting point for the crossover frequency, f_{CO} , to design the compensation.

$$f_{CO} = \sqrt{f_{P_mod} \times f_{Z_mod}} \quad (35)$$

$$f_{CO} = \sqrt{f_{P_mod} \times \frac{f_S}{2}} \quad (36)$$

For the example design, f_{P_mod} is 2.39 kHz and f_{Z_mod} is 1.33 MHz. [Equation 35](#) is the geometric mean of the modulator pole and the ESR zero and [Equation 36](#) is the mean of the modulator pole and the switching frequency. [Equation 35](#) yields 56.4 kHz and [Equation 36](#) results 51.3 kHz. Use the lower value of [Equation 35](#) or [Equation 36](#) for an initial crossover frequency.

For this example, the target value of f_{CO} is 51.3 kHz. Next, calculate the compensation components. Use a resistor in series with a capacitor to create a compensating zero. A capacitor in parallel to these two components forms the compensating pole.

The total loop gain, which consists of the product of the modulator gain, the feedback voltage-divider gain, and the error amplifier gain at f_{CO} equal to 1. Use Equation 37 to calculate the compensation resistor, R3 (see the schematic in Figure 16).

$$R3 = \left(\frac{2\pi \times f_{CO} \times C_O}{gm_{ps}} \right) \times \left(\frac{V_O}{V_{ref} \times gm_{ea}} \right) \quad (37)$$

Assume the power-stage transconductance, gm_{ps} , is 10.5 S. The output voltage (V_O), reference voltage (V_{ref}), and amplifier transconductance, (gm_{ea}) are 5 V, 0.8 V, and 310 μ S, respectively. The calculated value for R3 is 24.74 k Ω . For this design, use a value of 27 k Ω for R3. Use Equation 38 to set the compensation zero to the modulator pole frequency.

$$C1 = \frac{1}{2\pi \times R3 \times f_{P_mod}} \quad (38)$$

Equation 36 yields 2468 pF for compensating capacitor C1 (see the schematic in Figure 16). For this design, select a value of 2700 pF for C1.

To implement a compensation pole as needed, use an additional capacitor, C2, in parallel with the series combination of R3 and C1. Use Equation 39 and Equation 40 to calculate the value of C2 and select the larger resulting value to set the compensation pole. Type 2B compensation does not use C2 because it would demand a low ESR of the output capacitor.

$$C2 = \frac{C_O \times R_{ESR}}{R3} \quad (39)$$

$$C2 = \frac{1}{\pi \times R3 \times f_S} \quad (40)$$

8.2.1.2.10 LDO Regulator

Depending on the end application, use different values of external components can be used. To program the output voltage, carefully select the feedback resistors, R5 and R6 (see the schematic in Figure 16). Using smaller resistors results in higher current consumption, whereas using very large resistors impacts the sensitivity of the regulator. Therefore selecting feedback resistors such that the sum of R5 and R6 is between 20 k Ω and 200 k Ω is recommended.

If the desired regulated output voltage is 3.3 V on selecting R6, the value of R5 can be calculated. With $V_{ref} = 0.8$ V (typical), $V_O = 3.3$ V, and selecting R6 = 20 k Ω , the calculated value of R5 is 62 k Ω .

Depending on application requirements, a larger output capacitor for the LDO regulator may be required (see C7 in Figure 16) to prevent the output from temporarily dropping down during fast load steps. TI recommends a low-ESR ceramic capacitor with dielectric of type X5R or X7R. Additionally, a bypass capacitor can be connected at the output to decouple high-frequency noise based on the requirements of the end application.

8.2.1.2.11 Power Dissipation

8.2.1.2.11.1 Power Dissipation Losses of the Buck Regulator

Use the following equations to calculate the power dissipation losses for the buck regulator. These losses are applicable for continuous-conduction-mode (CCM) operation.

1. Conduction loss:

$$P_{CON} = I_O^2 \times r_{DS(on)} \times (V_O / V_I)$$

where

- I_O is the buck regulator output current
- V_O is the buck regulator output voltage
- V_I is the input voltage

(41)

2. Switching loss:

$$P_{SW} = \frac{1}{2} \times V_I \times I_O \times (t_r + t_f) \times f_S$$

where

- t_r is the FET switching rise time (t_r maximum = 20 ns)
- t_f is the FET switching fall time (t_f maximum = 20 ns)
- f_S is the switching frequency of the buck regulator

(42)

3. Gate drive loss:

$$P_{Gate} = V_{drive} \times Q_g \times f_{sw}$$

where

- V_{drive} is the FET gate-drive voltage (typically $V_{drive} = 6$ V)
- $Q_g = 1 \times 10^{-9}$ (nC, typical)

(43)

8.2.1.2.12 Power Dissipation Losses of the LDO Regulator

$$P_{LDO} = (V_{VIN_LDO} - V_{(LDO_OUT)}) \times I_{(LDO_OUT)}$$

(44)

8.2.1.2.13 Total Device Power Dissipation Losses and Junction Temperature

1. Supply loss:

$$P_{IC} = V_I \times I_{Q-normal}$$

(45)

2. Total power loss:

$$P_{Total} = P_{CON} + P_{SW} + P_{Gate} + P_{LDO} + P_{IC}$$

(46)

For a given operating ambient temperature T_A :

$$T_J = T_A + R_{th} \times P_{Total}$$

where

- T_J is the junction temperature in °C
- T_A is the ambient temperature in °C
- R_{th} is the thermal resistance of package in (°C/W)
- P_{Total} is the total power dissipation (W)

(47)

For a given maximum junction temperature $T_{J-max} = 150^\circ\text{C}$, the allowed Total power dissipation is given as:

$$T_{A-max} = T_{J-max} - R_{th} \times P_{Total}$$

(48)

where

- T_{A-max} is the maximum ambient temperature in °C
- T_{J-max} is the maximum junction temperature in °C

(49)

Additional power losses occur in the regulator circuit because of the inductor AC and DC losses, the Schottky diode, and trace resistance that impact the overall efficiency of the regulator.

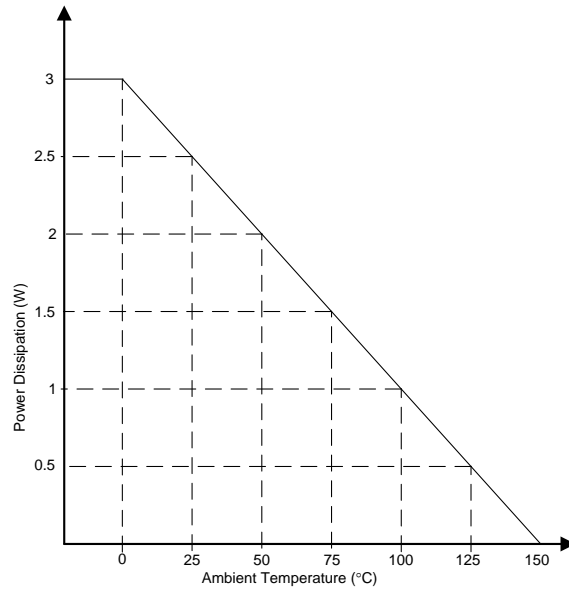

Figure 17. Thermal Derating

8.2.1.3 Application Curves

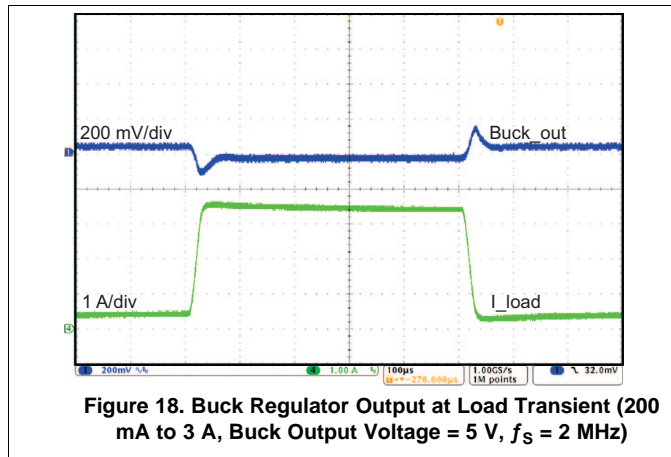

Figure 18. Buck Regulator Output at Load Transient (200 mA to 3 A, Buck Output Voltage = 5 V, $f_S = 2$ MHz)

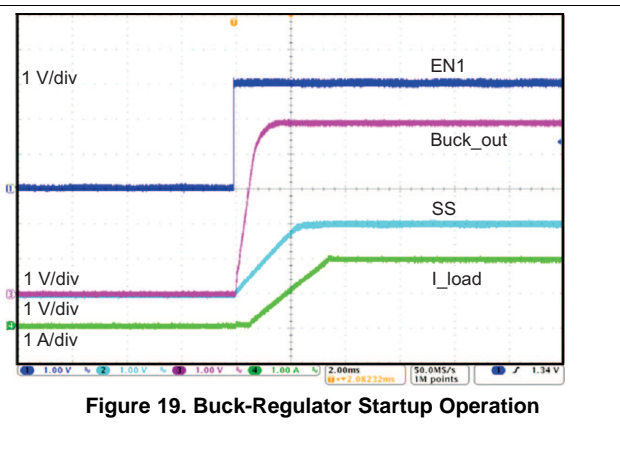

Figure 19. Buck-Regulator Startup Operation

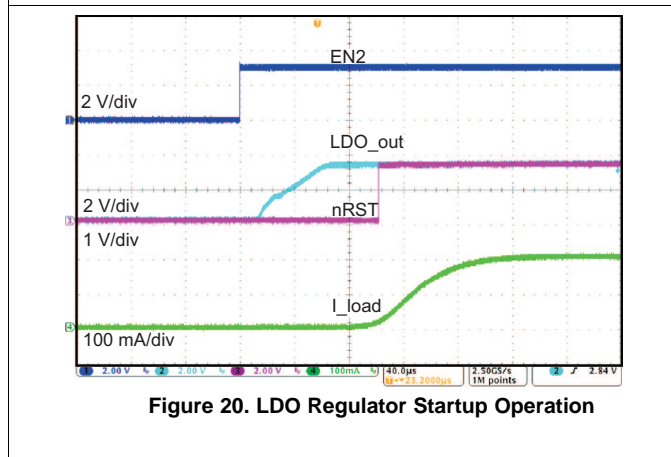

Figure 20. LDO Regulator Startup Operation

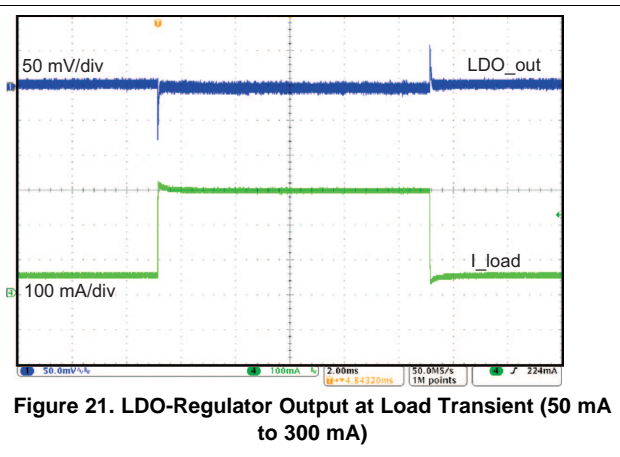
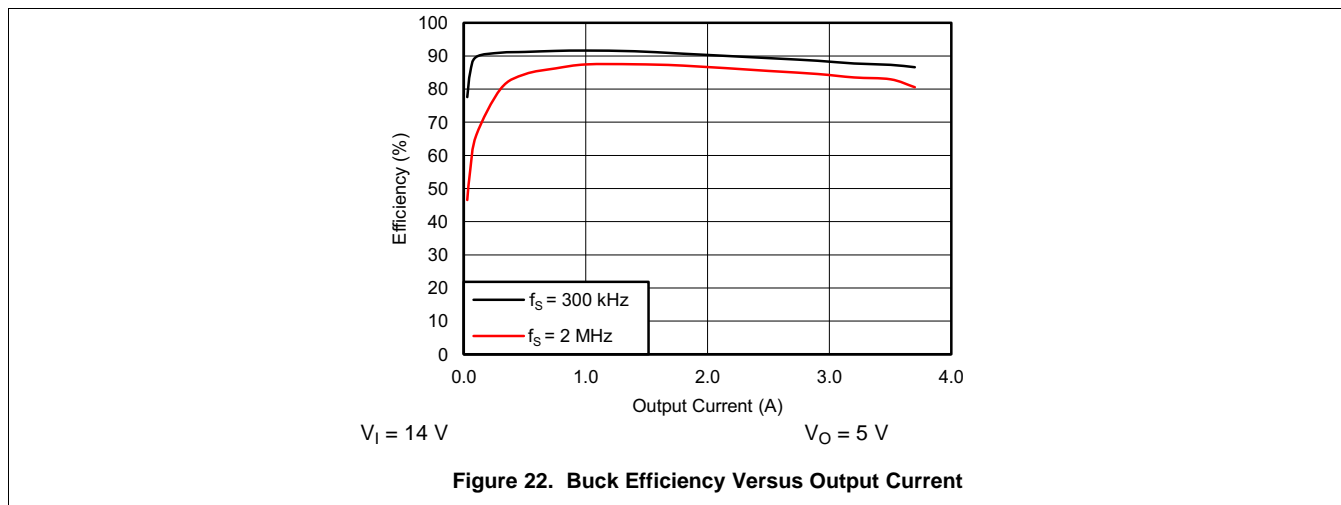
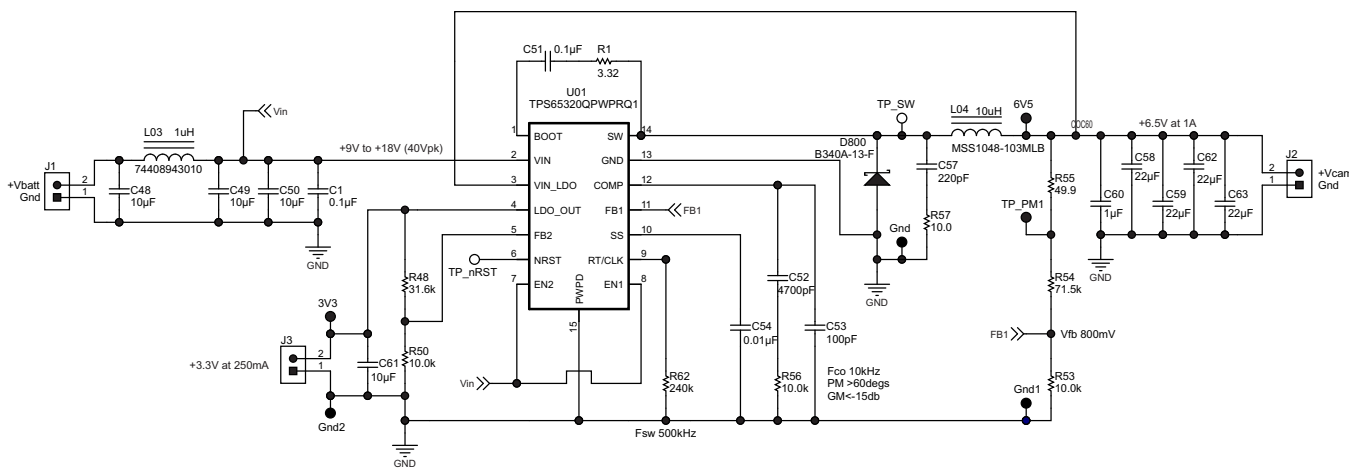

Figure 21. LDO-Regulator Output at Load Transient (50 mA to 300 mA)



8.2.2 Design Example With 500-kHz Switching Frequency



R55 is for test purposes only.

Figure 23. TPS65320-Q1 Design Example With 500-kHz Switching Frequency

8.2.2.1 Design Requirements

This example begins with the parameters listed in [Table 5](#).

Table 5. Design Parameters

DESIGN PARAMETER	EXAMPLE VALUE
Input voltage, VIN1	9 V to 18 V, typical 12 V
Output voltage, VREG1 (buck regulator)	6.5 V ± 2%
Maximum output current, I _{O_max1}	1 A
Minimum output current, I _{O_min1}	0.01 A
Transient response, 0.01 A to 1 A	3%
Output ripple voltage	1%
Switching frequency, f _{SW}	500 kHz
Output voltage, VREG2 (LDO regulator)	3.3 V ± 2%
Overshoot threshold	106% of output voltage
Undershoot threshold	91% of output voltage

8.2.2.2 Detailed Design Procedure

For the 500-kHz switching-frequency design, make the adjustments as outlined in the following sections. For sections such as LDO-component calculations, bootstrap-capacitor selection, and others that are not listed in this section, see the [2.2-MHz Switching Frequency, 9-V to 16-V Input, 5-V Output Buck Regulator, 3.3-V Output LDO Regulator](#) section.

8.2.2.2.1 Selecting the Switching Frequency

For 500-kHz operation, use a 240-k Ω resistor which is calculated using [Equation 3](#). The R62 resistor sets this switching frequency.

8.2.2.2.2 Output Inductor Selection

Using [Equation 21](#), the inductor value is calculated as 10.39 μ H with $K_{IND} = 0.8$. This design example can allow for a higher ripple current, therefore, select the nearest standard value of 10 μ H. The RMS and peak inductor-current ratings are calculated using [Equation 23](#) and [Equation 24](#) which result in 1.03 A and 1.42 A, respectively. The value of the output-filter inductor must not exceed the RMS-current and saturation-current ratings.

8.2.2.2.3 Output Capacitor

For this example, the specified transient load response is a 3% change in V_O for a load step from 0.01 A to 1 A (full load). For this example, $\Delta I_O = 1 - 0.01 = 0.99$ A and $\Delta V_O = 0.03 \times 6.5 = 0.195$ V. Using these numbers results in a minimum capacitance of 20.31 μ F. This value does not consider the ESR of the output capacitor in the output voltage change. For ceramic capacitors, the ESR is usually small enough to ignore in this calculation.

Aluminum electrolytic and tantalum capacitors have higher ESR that should be considered. The catch diode of the regulator cannot sink current, so any stored energy in the inductor produces an output-voltage overshoot when the load current rapidly decreases. Also, size the output capacitor to absorb the energy stored in the inductor when transitioning from a high load current to a lower load current. The excess energy that is stored in the output capacitor increases the voltage on the capacitor. Size the capacitor to maintain the desired output voltage during these transient periods. Use [Equation 26](#) to calculate the minimum capacitance to keep the output voltage overshoot to a desired value.

For this example, the worst-case load step is from 1 A to 0.01 A. The output voltage increases during this load transition, and the stated maximum in our specification is 3% of the output voltage resulting in $V_i = 1.03 \times 6.5 = 6.7$. V_i is the initial capacitor voltage, which is the nominal output voltage of 5 V. Using these values, [Equation 26](#) yields a minimum capacitance of 3.88 μ F. [Equation 27](#) calculates the minimum output capacitance required to meet the output ripple-voltage specification. [Equation 27](#) yields 10.6 μ F. [Equation 28](#) calculates the maximum ESR an output capacitor can have to meet the output ripple-voltage specification. [Equation 28](#) indicates the ESR should be less than 60.2 m Ω .

The most stringent criterion for the output capacitor is 20.31 μ F of capacitance to keep the output voltage in regulation during a load transient.

Factor in additional capacitance deratings for aging, temperature, and DC bias which increase this minimum value. For this example, four 22- μ F, 25-V and one 1- μ F, 25-V ceramic capacitors with 10 m Ω of ESR are used. Specify an output capacitor that can support the inductor ripple current. Some capacitor data sheets specify the RMS value of the maximum ripple current. Use [Equation 29](#) to calculate the RMS ripple current that the output capacitor must support. For this design example, [Equation 29](#) yields 240 mA.

8.2.2.2.4 Compensation

This design example use a different approach for calculating compensation values, beginning with the desired crossover frequency. Ensure that the crossover frequency is maintained at 10 kHz to provide reasonable phase margin (PM). To achieve circuit stability, a phase margin greater than 60 degrees and a gain margin less than 15 dB is required. Next, place the zero close to the load pole. The zero is determined using C52 and R56. For this example, select a value of 10 k Ω for R56 which results in a value of approximately 4.7 nF for C52. The pole, resulting from C53 and R56, can be placed between 10 times the crossover frequency and 1/3 of the switching frequency. The gain is adjusted to be maintained over 60 degrees of phase margin and -15 dB of gain margin. The resulting value of C53 is approximately 100 pF for a pole frequency of 159 kHz.

Use the following component values:

$$R56 = 10 \text{ k}\Omega$$

C53 = 100 pF
C52 = 4700 pF

8.2.2.3 Application Curve

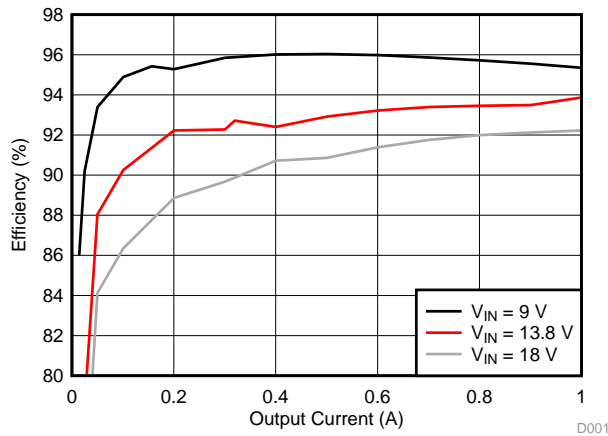

Figure 24. Efficiency vs Output Current

9 Power Supply Recommendations

The TPS65320-Q1 buck regulator is designed to operate from an input voltage up to 40 V. Ensure that the input supply is well regulated. Furthermore, if the supply voltage in the application is likely to reach negative voltage (for example, reverse battery) a forward diode must be placed at the input of the supply. For the VIN pin, a small ceramic capacitor with a typical value of 4.7 μF is recommended. Capacitance derating for aging, temperature, and DC bias must be taken into account while determining the capacitor value. Connect a local decoupling capacitor close to the VIN_LDO pin for proper filtering.

10 Layout

10.1 Layout Guidelines

TI recommends the following guidelines for PCB layout of the TPS65320-Q1 buck regulator. This layout example is based on TPS65320EVM ([SLVU691](#)).

10.1.1 Inductor (L)

Use a low-EMI inductor with a ferrite-type shielded core. Other types of inductors can be used; however, these inductors must have low-EMI characteristics and be located away from the low-power traces and components in the circuit.

10.1.2 Input Filter Capacitors (C_i)

Locate input ceramic filter capacitors in close proximity to the VIN pin. TI recommends surface-mount (SM) capacitors to minimize lead length and reduce noise coupling.

10.1.3 Resistive Feedback Networks

Route the feedback trace so that it has minimum interaction with any noise sources associated with the switching components. The recommended practice is to ensure the inductor is placed away from the feedback trace to prevent creating an EMI noise source.

10.1.4 Traces and Ground Plane

All power (high-current) traces should be as thick and short as possible. The inductor and output capacitor of the buck regulator should be as close to each other as possible which reduces EMI radiated by the power traces because of high switching currents. In a two-sided PCB, TI recommends having ground planes on both sides of the PCB to help reduce noise and ground loop errors. The ground connection for the input and output capacitors and IC ground should connect to this ground plane. In a multi-layer PCB, the ground plane separates the power plane (where high switching currents and components are) from the signal plane (where the feedback trace and components are) for improved performance. Also, arrange the components such that the switching-current loops curl in the same direction. Place the high-current components such that during conduction the current path is in the same direction which prevents magnetic field reversal caused by the traces between the two half-cycles, and helps reduce radiated EMI.

10.2 Layout Example

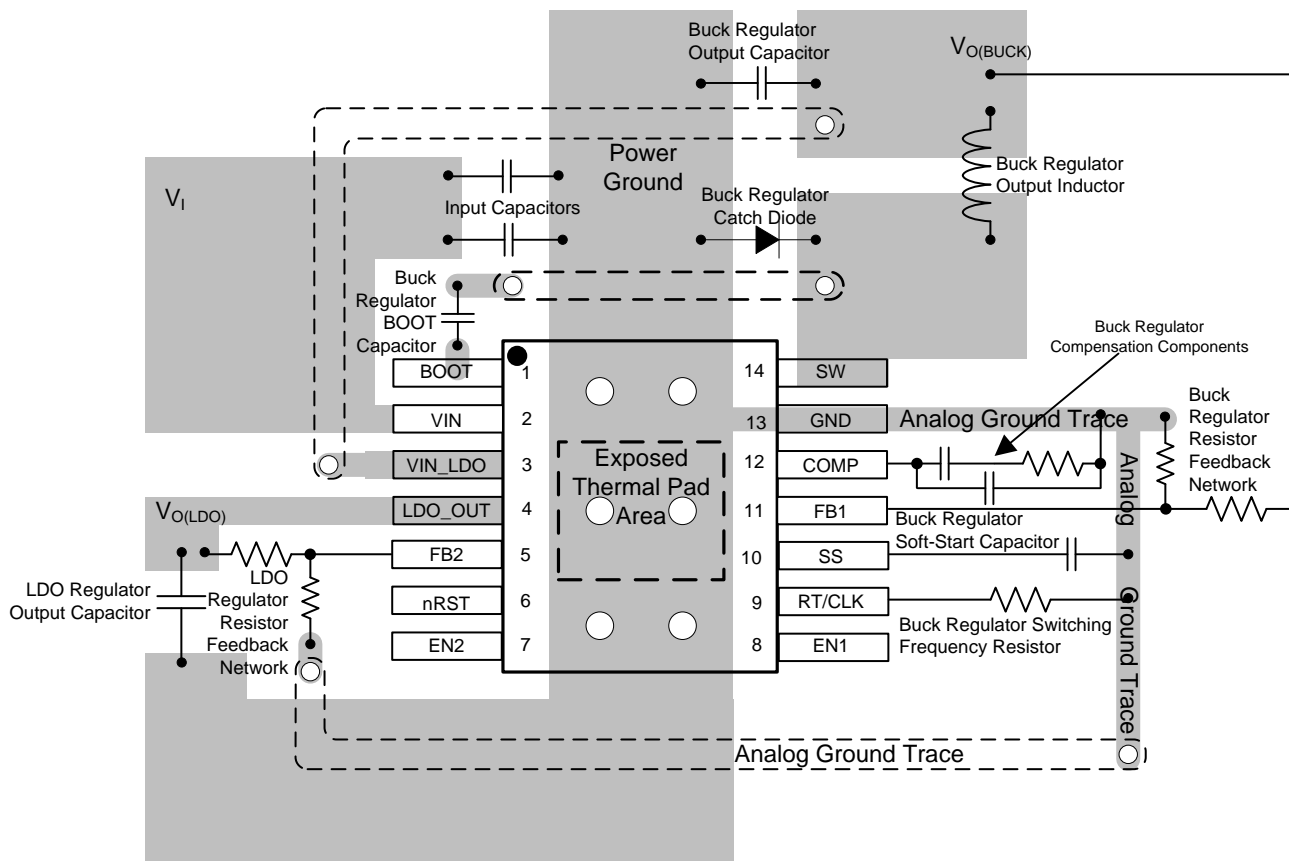

Figure 25. TPS65320-Q1 Layout Example

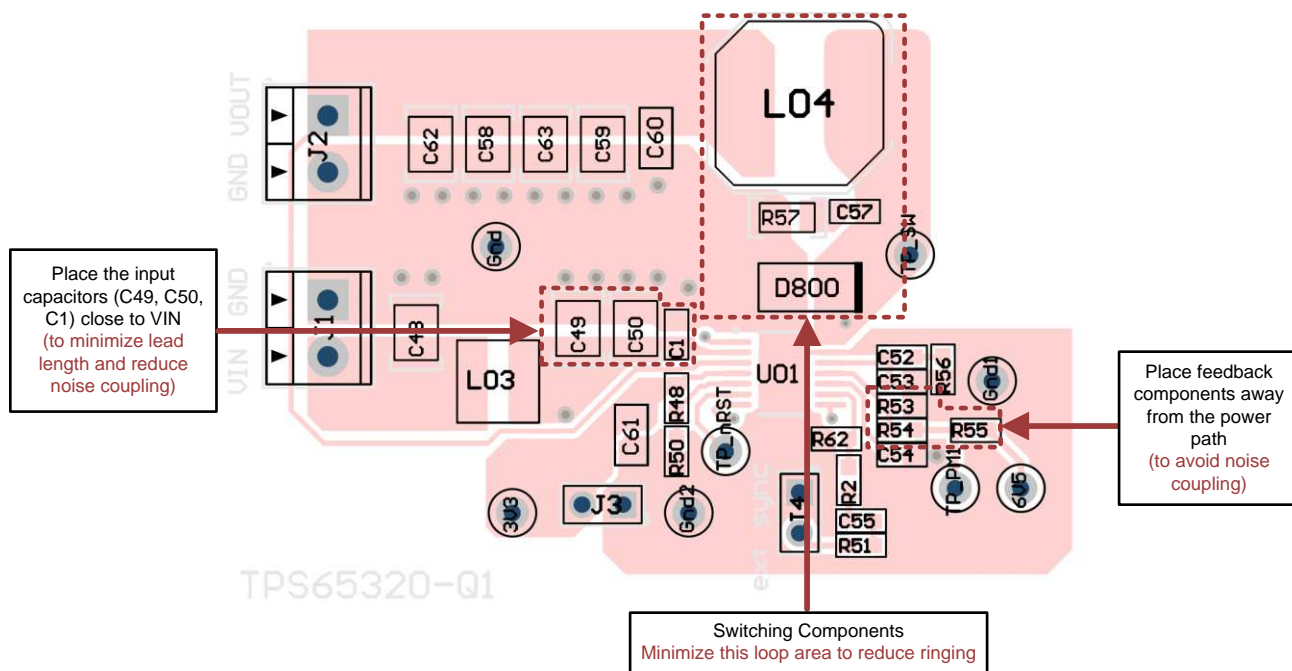

Figure 26. TPS65320-Q1 Layout Example — Top Side

Layout Example (continued)

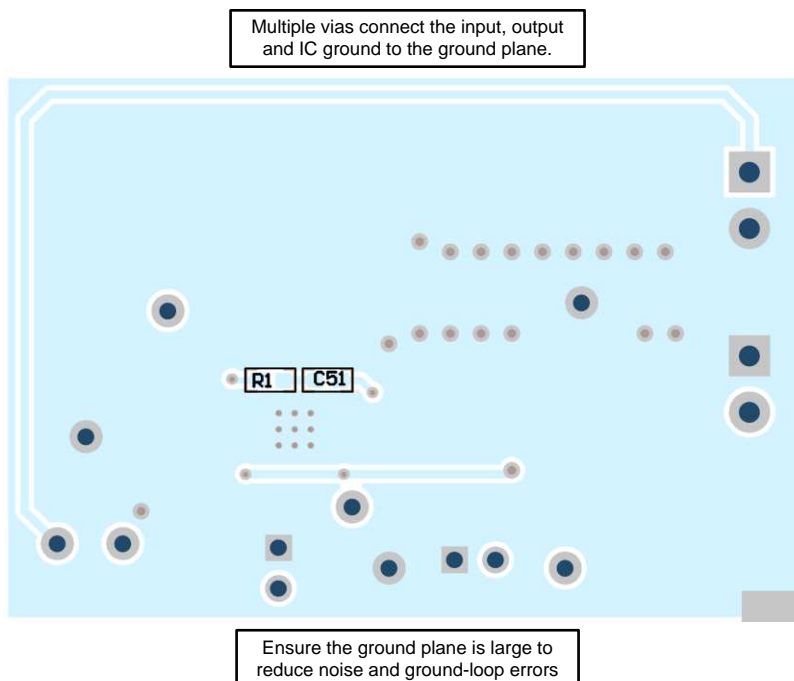

Figure 27. TPS65320-Q1 Layout Example — Bottom Side

11 Device and Documentation Support

11.1 Device Support

11.1.1 Third-Party Products Disclaimer

TI'S PUBLICATION OF INFORMATION REGARDING THIRD-PARTY PRODUCTS OR SERVICES DOES NOT CONSTITUTE AN ENDORSEMENT REGARDING THE SUITABILITY OF SUCH PRODUCTS OR SERVICES OR A WARRANTY, REPRESENTATION OR ENDORSEMENT OF SUCH PRODUCTS OR SERVICES, EITHER ALONE OR IN COMBINATION WITH ANY TI PRODUCT OR SERVICE.

11.2 Documentation Support

11.2.1 Related Documentation

For related documentation see the following:

- *TPS65320-Q1 Design Checklist*, [SLVA593](#)
- *CISPR25 Radiated Emissions Using TPS65320-Q1*, [SLVA702](#)
- User's guide, *TPS65320EVM*, [SLVU691](#)

11.3 Community Resource

The following links connect to TI community resources. Linked contents are provided "AS IS" by the respective contributors. They do not constitute TI specifications and do not necessarily reflect TI's views; see TI's [Terms of Use](#).

TI E2E™ Online Community *TI's Engineer-to-Engineer (E2E) Community*. Created to foster collaboration among engineers. At e2e.ti.com, you can ask questions, share knowledge, explore ideas and help solve problems with fellow engineers.

Design Support *TI's Design Support* Quickly find helpful E2E forums along with design support tools and contact information for technical support.

11.4 Trademarks

Eco-mode, PowerPAD, E2E are trademarks of Texas Instruments.
All other trademarks are the property of their respective owners.

11.5 Electrostatic Discharge Caution



These devices have limited built-in ESD protection. The leads should be shorted together or the device placed in conductive foam during storage or handling to prevent electrostatic damage to the MOS gates.

11.6 Glossary

[SLYZ022](#) — *TI Glossary*.

This glossary lists and explains terms, acronyms, and definitions.

12 Mechanical, Packaging, and Orderable Information

The following pages include mechanical, packaging, and orderable information. This information is the most current data available for the designated devices. This data is subject to change without notice and revision of this document. For browser-based versions of this data sheet, refer to the left-hand navigation.

PACKAGING INFORMATION

Orderable Device	Status (1)	Package Type	Package Drawing	Pins	Package Qty	Eco Plan (2)	Lead/Ball Finish (6)	MSL Peak Temp (3)	Op Temp (°C)	Device Marking (4/5)	Samples
TPS65320BQPWRQ1	NRND	HTSSOP	PWP	14	2000	Green (RoHS & no Sb/Br)	CU NIPDAU	Level-3-260C-168 HR	-40 to 125	T65320B	
TPS65320QPWRQ1	NRND	HTSSOP	PWP	14	2000	Green (RoHS & no Sb/Br)	CU NIPDAU	Level-3-260C-168 HR	-40 to 125	TPS65320	

(1) The marketing status values are defined as follows:

ACTIVE: Product device recommended for new designs.

LIFEBUY: TI has announced that the device will be discontinued, and a lifetime-buy period is in effect.

NRND: Not recommended for new designs. Device is in production to support existing customers, but TI does not recommend using this part in a new design.

PREVIEW: Device has been announced but is not in production. Samples may or may not be available.

OBSOLETE: TI has discontinued the production of the device.

(2) Eco Plan - The planned eco-friendly classification: Pb-Free (RoHS), Pb-Free (RoHS Exempt), or Green (RoHS & no Sb/Br) - please check <http://www.ti.com/productcontent> for the latest availability information and additional product content details.

TBD: The Pb-Free/Green conversion plan has not been defined.

Pb-Free (RoHS): TI's terms "Lead-Free" or "Pb-Free" mean semiconductor products that are compatible with the current RoHS requirements for all 6 substances, including the requirement that lead not exceed 0.1% by weight in homogeneous materials. Where designed to be soldered at high temperatures, TI Pb-Free products are suitable for use in specified lead-free processes.

Pb-Free (RoHS Exempt): This component has a RoHS exemption for either 1) lead-based flip-chip solder bumps used between the die and package, or 2) lead-based die adhesive used between the die and leadframe. The component is otherwise considered Pb-Free (RoHS compatible) as defined above.

Green (RoHS & no Sb/Br): TI defines "Green" to mean Pb-Free (RoHS compatible), and free of Bromine (Br) and Antimony (Sb) based flame retardants (Br or Sb do not exceed 0.1% by weight in homogeneous material)

(3) MSL, Peak Temp. - The Moisture Sensitivity Level rating according to the JEDEC industry standard classifications, and peak solder temperature.

(4) There may be additional marking, which relates to the logo, the lot trace code information, or the environmental category on the device.

(5) Multiple Device Markings will be inside parentheses. Only one Device Marking contained in parentheses and separated by a "~" will appear on a device. If a line is indented then it is a continuation of the previous line and the two combined represent the entire Device Marking for that device.

(6) Lead/Ball Finish - Orderable Devices may have multiple material finish options. Finish options are separated by a vertical ruled line. Lead/Ball Finish values may wrap to two lines if the finish value exceeds the maximum column width.

Important Information and Disclaimer: The information provided on this page represents TI's knowledge and belief as of the date that it is provided. TI bases its knowledge and belief on information provided by third parties, and makes no representation or warranty as to the accuracy of such information. Efforts are underway to better integrate information from third parties. TI has taken and continues to take reasonable steps to provide representative and accurate information but may not have conducted destructive testing or chemical analysis on incoming materials and chemicals. TI and TI suppliers consider certain information to be proprietary, and thus CAS numbers and other limited information may not be available for release.

In no event shall TI's liability arising out of such information exceed the total purchase price of the TI part(s) at issue in this document sold by TI to Customer on an annual basis.

TAPE AND REEL INFORMATION

QUADRANT ASSIGNMENTS FOR PIN 1 ORIENTATION IN TAPE

*All dimensions are nominal

Device	Package Type	Package Drawing	Pins	SPQ	Reel Diameter (mm)	Reel Width W1 (mm)	A0 (mm)	B0 (mm)	K0 (mm)	P1 (mm)	W (mm)	Pin1 Quadrant
TPS65320BQPWPRQ1	HTSSOP	PWP	14	2000	330.0	12.4	6.9	5.6	1.6	8.0	12.0	Q1
TPS65320QPWPRQ1	HTSSOP	PWP	14	2000	330.0	12.4	6.9	5.6	1.6	8.0	12.0	Q1

TAPE AND REEL BOX DIMENSIONS

*All dimensions are nominal

Device	Package Type	Package Drawing	Pins	SPQ	Length (mm)	Width (mm)	Height (mm)
TPS65320BQPWRQ1	HTSSOP	PWP	14	2000	350.0	350.0	43.0
TPS65320QPWRQ1	HTSSOP	PWP	14	2000	350.0	350.0	43.0

PWP (R-PDSO-G14)

PowerPAD™ PLASTIC SMALL OUTLINE

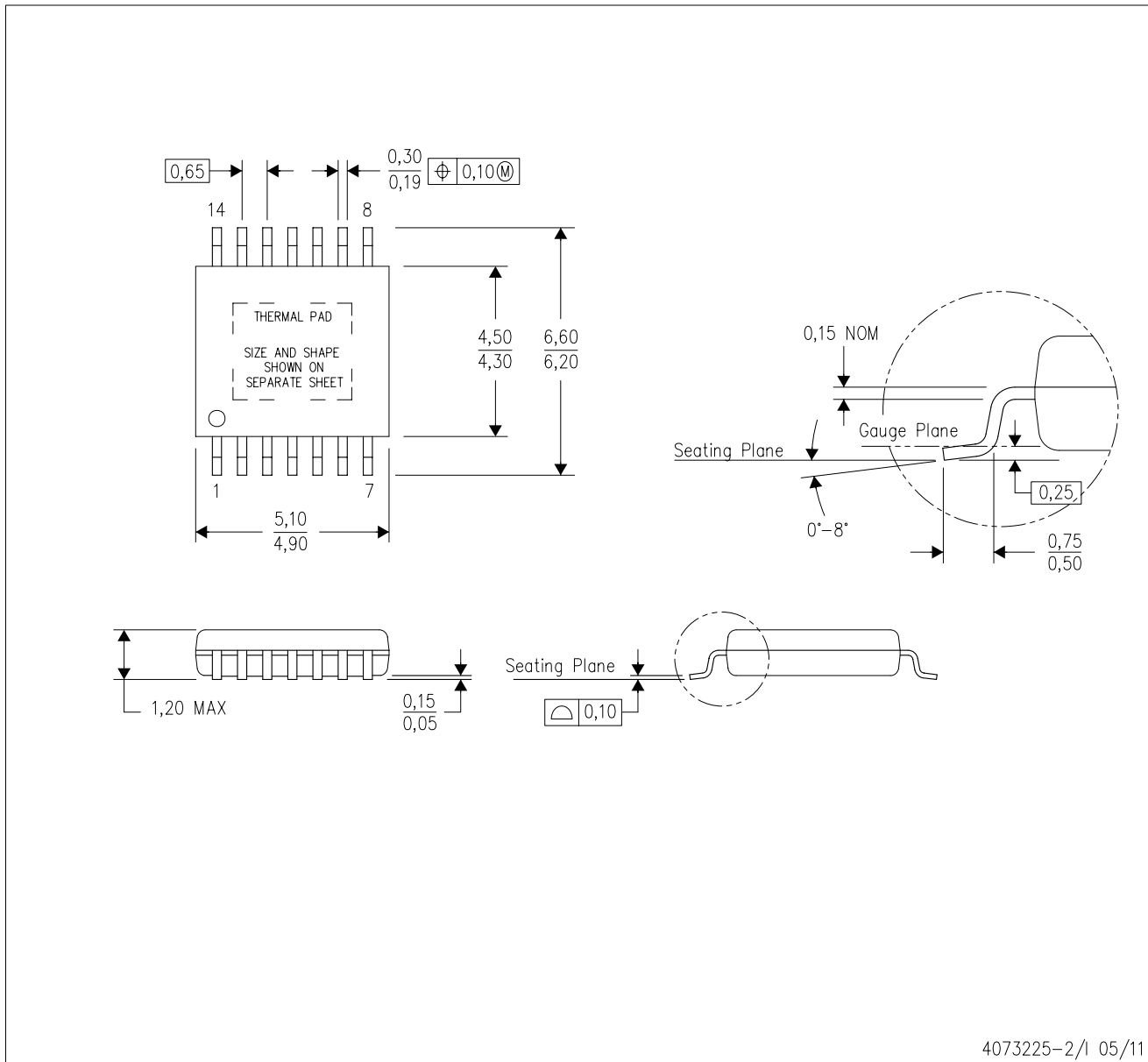

4073225-2/1 05/11

- NOTES:
- All linear dimensions are in millimeters.
 - This drawing is subject to change without notice.
 - Body dimensions do not include mold flash or protrusions. Mold flash and protrusion shall not exceed 0.15 per side.
 - This package is designed to be soldered to a thermal pad on the board. Refer to Technical Brief, PowerPad Thermally Enhanced Package, Texas Instruments Literature No. SLMA002 for information regarding recommended board layout. This document is available at www.ti.com <<http://www.ti.com>>.
 - See the additional figure in the Product Data Sheet for details regarding the exposed thermal pad features and dimensions.
 - Falls within JEDEC MO-153

PowerPAD is a trademark of Texas Instruments.

THERMAL PAD MECHANICAL DATA

PWP (R-PDSO-G14)

PowerPAD™ SMALL PLASTIC OUTLINE

THERMAL INFORMATION

This PowerPAD™ package incorporates an exposed thermal pad that is designed to be attached to a printed circuit board (PCB). The thermal pad must be soldered directly to the PCB. After soldering, the PCB can be used as a heatsink. In addition, through the use of thermal vias, the thermal pad can be attached directly to the appropriate copper plane shown in the electrical schematic for the device, or alternatively, can be attached to a special heatsink structure designed into the PCB. This design optimizes the heat transfer from the integrated circuit (IC).

For additional information on the PowerPAD package and how to take advantage of its heat dissipating abilities, refer to Technical Brief, PowerPAD Thermally Enhanced Package, Texas Instruments Literature No. SLMA002 and Application Brief, PowerPAD Made Easy, Texas Instruments Literature No. SLMA004. Both documents are available at www.ti.com.

The exposed thermal pad dimensions for this package are shown in the following illustration.

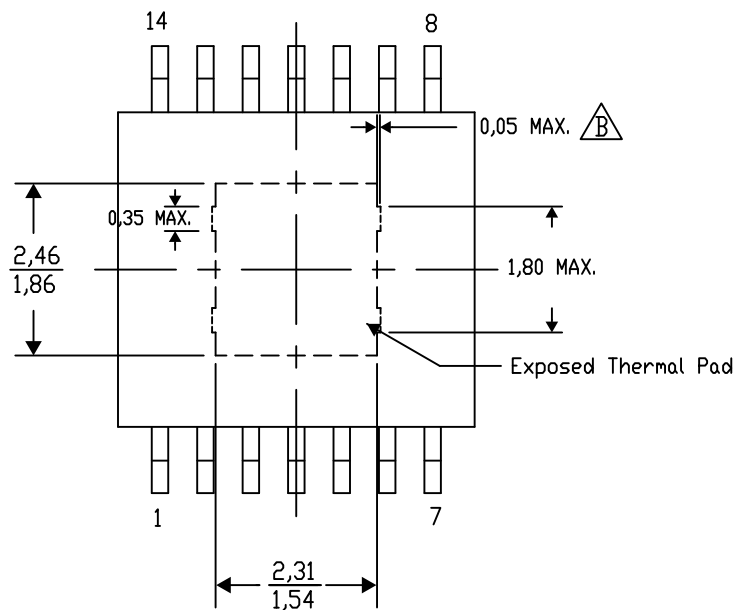

Top View

Exposed Thermal Pad Dimensions

4206332-44/AO 01/16

NOTE: A. All linear dimensions are in millimeters

$\triangle B$ Exposed tie strap features may not be present.

PowerPAD is a trademark of Texas Instruments

PWP (R-PDSO-G14)

PowerPAD™ PLASTIC SMALL OUTLINE

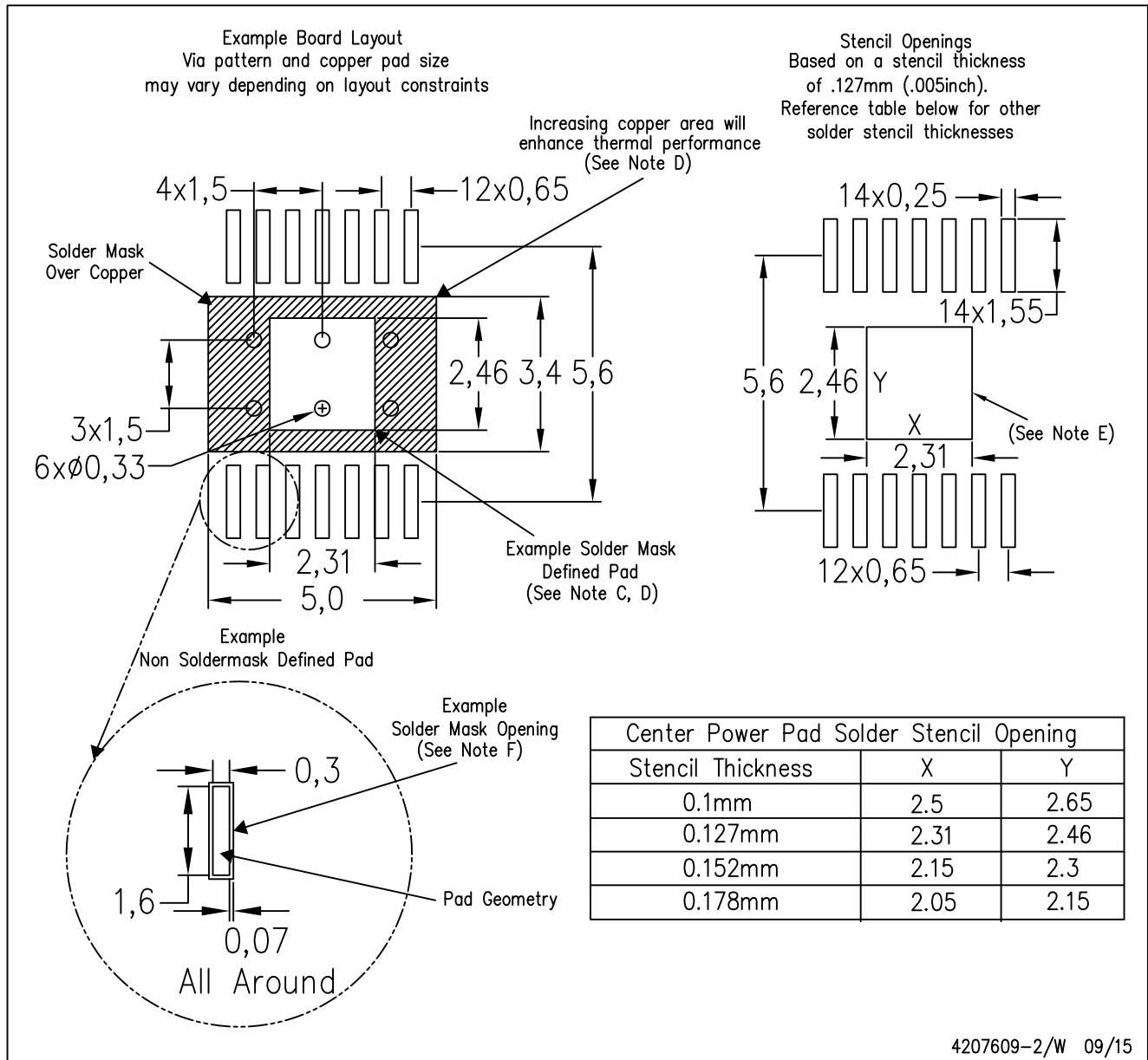

- NOTES:
- A. All linear dimensions are in millimeters.
 - B. This drawing is subject to change without notice.
 - C. Customers should place a note on the circuit board fabrication drawing not to alter the center solder mask defined pad.
 - D. This package is designed to be soldered to a thermal pad on the board. Refer to Technical Brief, PowerPAD Thermally Enhanced Package, Texas Instruments Literature No. SLMA002, SLMA004, and also the Product Data Sheets for specific thermal information, via requirements, and recommended board layout. These documents are available at www.ti.com <<http://www.ti.com>>. Publication IPC-7351 is recommended for alternate designs.
 - E. Laser cutting apertures with trapezoidal walls and also rounding corners will offer better paste release. Customers should contact their board assembly site for stencil design recommendations. Example stencil design based on a 50% volumetric metal load solder paste. Refer to IPC-7525 for other stencil recommendations.
 - F. Customers should contact their board fabrication site for solder mask tolerances between and around signal pads.

IMPORTANT NOTICE AND DISCLAIMER

TI PROVIDES TECHNICAL AND RELIABILITY DATA (INCLUDING DATASHEETS), DESIGN RESOURCES (INCLUDING REFERENCE DESIGNS), APPLICATION OR OTHER DESIGN ADVICE, WEB TOOLS, SAFETY INFORMATION, AND OTHER RESOURCES "AS IS" AND WITH ALL FAULTS, AND DISCLAIMS ALL WARRANTIES, EXPRESS AND IMPLIED, INCLUDING WITHOUT LIMITATION ANY IMPLIED WARRANTIES OF MERCHANTABILITY, FITNESS FOR A PARTICULAR PURPOSE OR NON-INFRINGEMENT OF THIRD PARTY INTELLECTUAL PROPERTY RIGHTS.

These resources are intended for skilled developers designing with TI products. You are solely responsible for (1) selecting the appropriate TI products for your application, (2) designing, validating and testing your application, and (3) ensuring your application meets applicable standards, and any other safety, security, or other requirements. These resources are subject to change without notice. TI grants you permission to use these resources only for development of an application that uses the TI products described in the resource. Other reproduction and display of these resources is prohibited. No license is granted to any other TI intellectual property right or to any third party intellectual property right. TI disclaims responsibility for, and you will fully indemnify TI and its representatives against, any claims, damages, costs, losses, and liabilities arising out of your use of these resources.

TI's products are provided subject to TI's Terms of Sale (www.ti.com/legal/termsofsale.html) or other applicable terms available either on ti.com or provided in conjunction with such TI products. TI's provision of these resources does not expand or otherwise alter TI's applicable warranties or warranty disclaimers for TI products.

Mailing Address: Texas Instruments, Post Office Box 655303, Dallas, Texas 75265
Copyright © 2019, Texas Instruments Incorporated

Looking for pricing, stock, or lifecycle information?

Click below to explore more details on WIN SOURCE:

 [View TPS65320BQPWPRQ1](#) on WIN SOURCE

 [Texas Instruments](#) Information

Optimize Your Supply Chain with WIN SOURCE Solutions

-  Global Sourcing Solution
-  Obsolete Management
-  Cost Control Management
-  Shortage Management
-  Alternative Solution
-  Excess Inventory Management