

# DATA SHEET

## CURRENT SENSOR - LOW TCR

PR series

5%, 1%

sizes 0805/1206/2010/2512

RoHS compliant & Halogen free



SCOPE

This specification describes PR series current sensor - low TCR with lead-free terminations made by metal substrate.

APPLICATIONS

- Consumer goods
- Computer
- Telecom / Datacom
- Industrial / Power supply
- Alternative Energy

FEATURES

- Halogen-free Epoxy
- RoHS compliant
- Reduce environmentally hazardous wastes
- High component and equipment reliability
- Non-forbidden materials used in products/production
- Low resistances applied to current sensing

ORDERING INFORMATION - GLOBAL PART NUMBER

Global part numbers are identified by the series, size, tolerance, packing type, temperature coefficient, taping reel and resistance value.

**GLOBAL PART NUMBER**

**PR XXXX X X X XX XXXX Z**  
 (1) (2) (3) (4) (5) (6) (7)

**(1) SIZE**

0805/1206 / 2010 / 2512

**(2) TOLERANCE**

F = ±1%  
 J = ±5%

**(3) PACKAGING TYPE**

R = Paper taping reel  
 K = Embossed taping reel

**(4) TEMPERATURE COEFFICIENT OF RESISTANCE**

D = ±25 ppm/°C  
 E = ±50 ppm/°C  
 F = ±100ppm/°C

**(5) TAPING REEL**

07 / 7W / 7T / 47 = 7 inch dia. Reel and specific rated power  
 Detailed power rating are shown in the Table 2.

**(6) RESISTANCE VALUE**

0.5 mΩ to 100 mΩ  
 There are 3~5 digits indicated the resistance value.  
 Detailed coding rules of resistance are shown in the table of "Resistance rule of global part number".

**(7) DEFAULT CODE**

Letter Z is the system default code for ordering only. <sup>(Note)</sup>

Resistance rule of global part number

Resistance code rule	Example
0RXXX	0U5 = 0.5 mΩ
(0.5 to 100 mΩ)	0R001 = 1 mΩ
	0R1 = 100 mΩ

**ORDERING EXAMPLE**

The ordering code of a PR1206 1/4W chip resistor, TC50, value 0.003Ω with ± 1% tolerance, supplied in 7-inch tape reel is: PR1206FKE070R003Z

**NOTE**

1. All our RChip products are RoHS compliant. "LFP" of the internal 2D reel label mentions "Lead-Free Process"

MARKING

**PR0805**

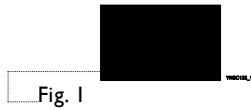

No marking

**PR1206 / PR2010 / PR2512**

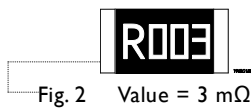

Fig. 2 Value = 3 mΩ

4 digits

The “R” is used as a decimal point; the other 3 digits are significant

PR1206: 1 mΩ to 50 mΩ

PR2010: 4 mΩ to 100 mΩ

PR2512: 5 mΩ to 100 mΩ

**PR2010 / PR2512**

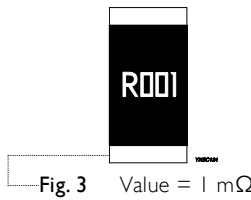

Fig. 3 Value = 1 mΩ

4 digits

The “R” is used as a decimal point; the other 3 digits are significant

PR2010: 1 mΩ to 3 mΩ

PR2512: 1 mΩ to 4 mΩ

**PR2512**

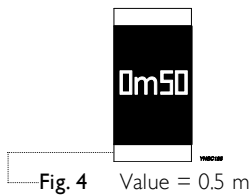

Fig. 4 Value = 0.5 mΩ

4 digits

The “m” is used as a decimal point; the other 3 digits are significant and the unit is milliohm

PR2512: 0.5 mΩ to 2.5 mΩ

CONSTRUCTION

The resistors are constructed using outstanding TCR level material, which makes Yageo PR resistors excellent for current sensing application in battery charger circuit & DC-DC converter.

The composition of the resistive material is adjusted to give the approximate required resistance and is covered with a protective coating. Marking is printed on the top side of the resistor.

Finally, the three external terminations (Cu / Ni / matte Tin) are added, as shown in Fig. 5.

**Outlines**

For dimensions, please refer to Table I

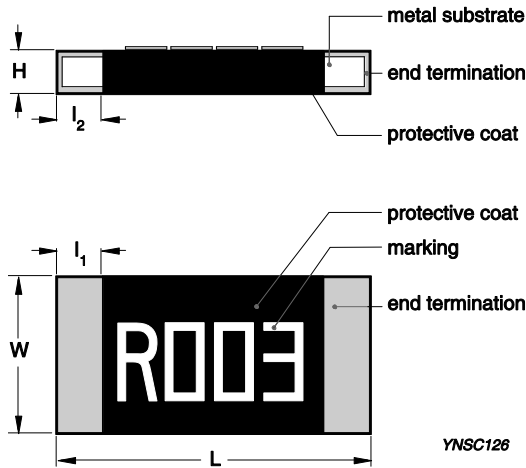

Fig. 5 PR1206~PR2512 Chip resistor outlines

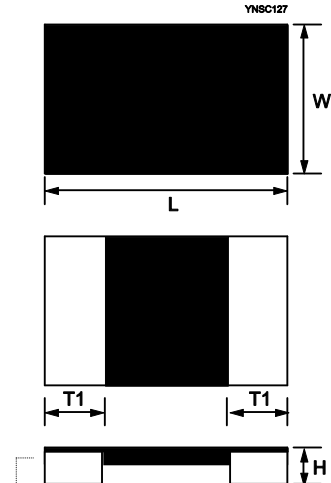

Fig. 5-1 PR0805 Chip resistor outlines

**DIMENSION**

Table I For outlines, please refer to Fig. 5

TYPE	RESISTANCE RANGE	POWER RATING	L (mm)	W (mm)	H (mm)	l <sub>1</sub> (mm)	l <sub>2</sub> (mm)
PR0805	3mΩ ≤ R ≤ 50mΩ	1/8W, 1/4W, 1/2W	2.03±0.25	1.27±0.25	0.30±0.25	0.35±0.25	--
	1mΩ		3.20±0.25	1.60±0.25	0.64±0.25	0.50±0.25	0.50±0.25
PR1206	2mΩ ≤ R ≤ 4mΩ	1/4W, 1/2W, 1W	3.20±0.25	1.60±0.25	0.55±0.25	0.50±0.25	0.50±0.25
	5mΩ		3.20±0.25	1.60±0.25	0.55±0.25	0.60±0.25	0.60±0.25
	6mΩ ≤ R ≤ 50mΩ		3.20±0.25	1.60±0.25	0.55±0.25	0.50±0.25	0.50±0.25
PR2010	1mΩ ≤ R ≤ 3mΩ	1/2W, 1W	5.08±0.25	2.54±0.25	0.78±0.25	1.30±0.25	1.30±0.25
	3mΩ < R ≤ 4mΩ		5.08±0.25	2.54±0.25	0.64±0.25	0.78±0.25	0.78±0.25
	4mΩ < R ≤ 100mΩ		5.08±0.25	2.54±0.25	0.64±0.25	0.78±0.25	0.78±0.25
	0.5mΩ ≤ R ≤ 3mΩ	1W	6.25±0.25	3.20±0.25	0.78±0.25	1.88±0.25	1.88±0.25
	3mΩ < R ≤ 4mΩ		6.25±0.25	3.20±0.25	0.78±0.25	1.88±0.25	1.88±0.25
	4mΩ < R ≤ 75mΩ		6.25±0.25	3.20±0.25	0.64±0.25	1.11±0.25	1.11±0.25
75mΩ < R ≤ 100mΩ	6.25±0.25		3.20±0.25	0.64±0.25	0.86±0.25	0.86±0.25	
PR22512	0.5mΩ ≤ R ≤ 3mΩ	2W	6.25±0.25	3.20±0.25	0.78±0.25	1.88±0.25	1.88±0.25
	3mΩ < R ≤ 4mΩ		6.25±0.25	3.20±0.25	0.78±0.25	1.88±0.25	1.88±0.25
	4mΩ < R ≤ 75mΩ	3W	6.25±0.25	3.20±0.25	0.64±0.25	1.11±0.25	1.11±0.25
	0.5mΩ		6.25±0.25	3.20±0.25	0.78±0.25	1.88±0.25	1.88±0.25
	0.5mΩ < R ≤ 3mΩ		6.25±0.25	3.20±0.25	0.78±0.25	1.11±0.25	1.11±0.25
	3mΩ ≤ R ≤ 4mΩ		6.25±0.25	3.20±0.25	0.78±0.25	1.67±0.25	1.67±0.25
	4mΩ < R ≤ 10mΩ		6.25±0.25	3.20±0.25	0.64±0.25	1.11±0.25	1.11±0.25

**Note:**

1. For relevant physical dimensions, please refer to construction outlines.
2. Please contact with sales offices, distributors and representatives in your region before ordering.

**ELECTRICAL CHARACTERISTICS**

Table 2

SERIES	SIZE	POWER RATING (1)				TOLERANCE	RESISTANCE RANGE	TEMPERATURE COEFFICIENT OF RESISTANCE	
		07	7W	7T	47				
PR	0805	1/8W	1/4W	1/2W	1W		$3m\Omega \leq R \leq 50m\Omega$	$3m\Omega \leq R < 5m\Omega$	$\pm 100ppm/^{\circ}C$
								$5m\Omega \leq R \leq 50m\Omega$	$\pm 50ppm/^{\circ}C$
	1206	1/4W	1/2W	---	1W	$\pm 1\%$	$1m\Omega \leq R \leq 50m\Omega$		$\pm 50ppm/^{\circ}C$
	2010	1/2W	1W	---	---	$\pm 5\%$	$1m\Omega \leq R \leq 100m\Omega$		
	2512	1W	2W	3W	---		$0.5m\Omega \leq R \leq 100m\Omega$	$0.5m\Omega \leq R \leq 3m\Omega$	$\pm 50ppm/^{\circ}C$
								$3m\Omega < R \leq 100m\Omega$	$\pm 25ppm/^{\circ}C$

Note: 1. Please contact with sales offices, distributors and representatives in your region before ordering.

**FUNCTIONAL DESCRIPTION**

**OPERATING TEMPERATURE RANGE**

PR0805 Range: -55°C to + 150°C

PR1206~PR2512 Range: -55°C to + 170°C

**POWER RATING**

Standard rated power at 70°C:

PR0805: 1/8W

PR1206: 1/4W

PR2010: 1/2W

PR2512: 1W

For detail power value, please refer to Table 2.

**RATED VOLTAGE**

The DC or AC (rms) continuous working voltage corresponding to the rated power is determined by the following formula:

$$V = \sqrt{(P \times R)}$$

Where

V = Continuous rated DC or AC (rms) working voltage (V)

P = Rated power (W)

R = Resistance value ( $\Omega$ )

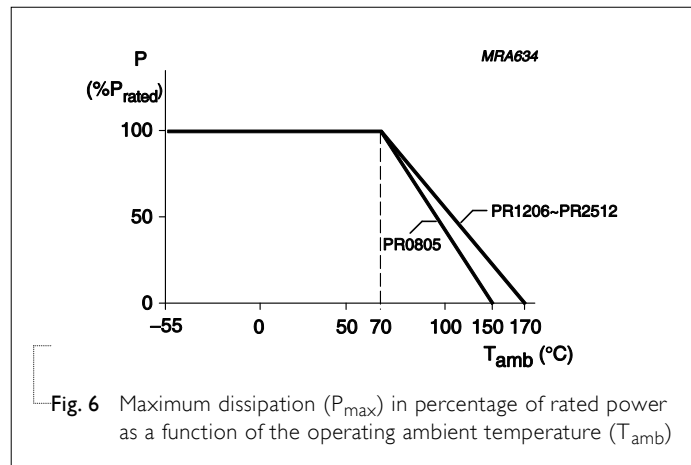

Fig. 6 Maximum dissipation (P<sub>max</sub>) in percentage of rated power as a function of the operating ambient temperature (T<sub>amb</sub>)

**PACKING STYLE AND PACKAGING QUANTITY**

Table 3 Packing style and packaging quantity

PACKING STYLE	REEL DIMENSION	PR0805	PR1206	PR2010	PR2512
Paper taping reel (R)	7" (178 mm)	5,000	---	---	---
Embossed taping reel (K)		---	4,000	2,000	4,000

**EMBOSSED TAPE**

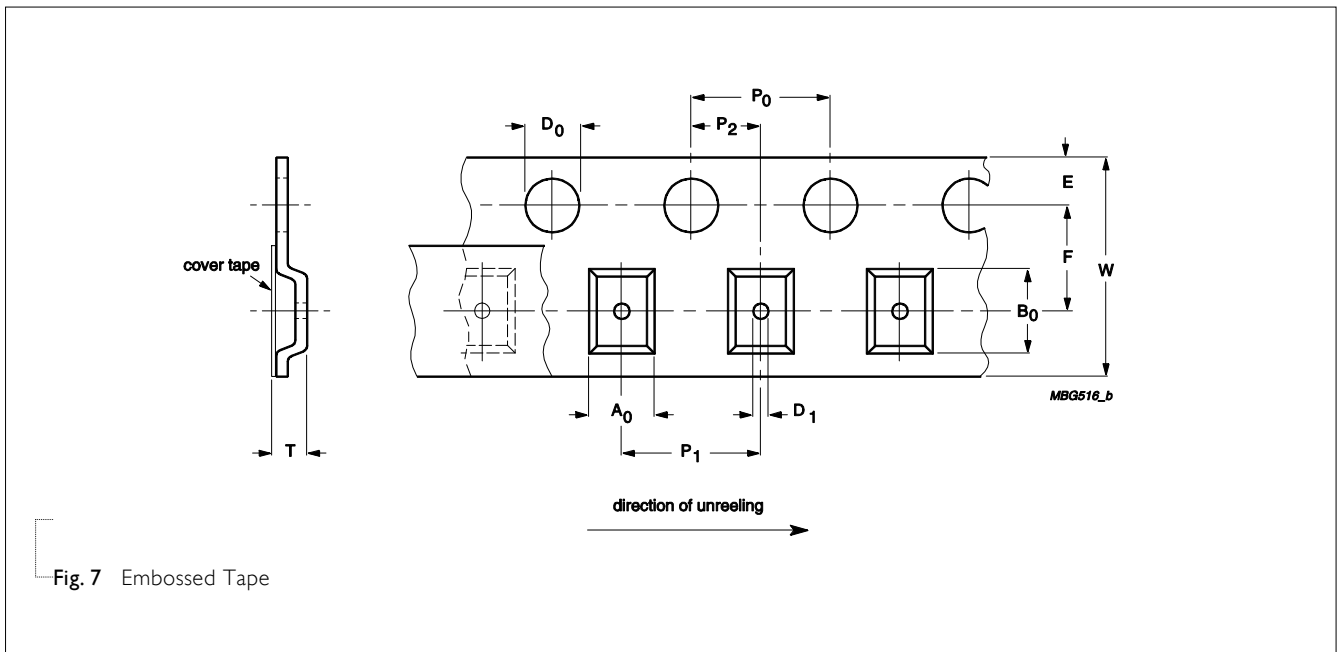

Fig. 7 Embossed Tape

Table 4 Dimensions of embossed tape for relevant chip resistors size

SIZE	SYMBOL											Unit: mm
	A <sub>0</sub>	B <sub>0</sub>	W	E	F	P <sub>0</sub>	P <sub>1</sub>	P <sub>2</sub>	ØD <sub>0</sub>	ØD <sub>1</sub>	T	
PR0805	1.60±0.15	2.30±0.15	8.00±0.30	1.75±0.10	3.50±0.10	4.00±0.10	4.00±0.10	2.00±0.10	1.50±0.10	---	0.40+0.20/-0	
PR1206	1.83±0.10	3.50±0.10	8.00±0.15	1.75±0.10	3.50±0.10	4.00±0.10	4.00±0.10	2.00±0.10	1.55±0.05	1.00±0.10	0.90±0.10	
PR2010	2.90±0.10	5.45±0.10	12.00±0.15	1.75±0.10	5.50±0.10	4.00±0.10	4.00±0.10	2.00±0.10	1.50±0.05	1.50±0.10	1.10±0.10	
PR2512	3.90±0.10	6.74±0.10	12.00±0.15	1.75±0.10	5.50±0.10	4.00±0.10	4.00±0.10	2.00±0.10	1.55±0.05	1.50±0.10	1.08±0.10	

**REEL SPECIFICATION**

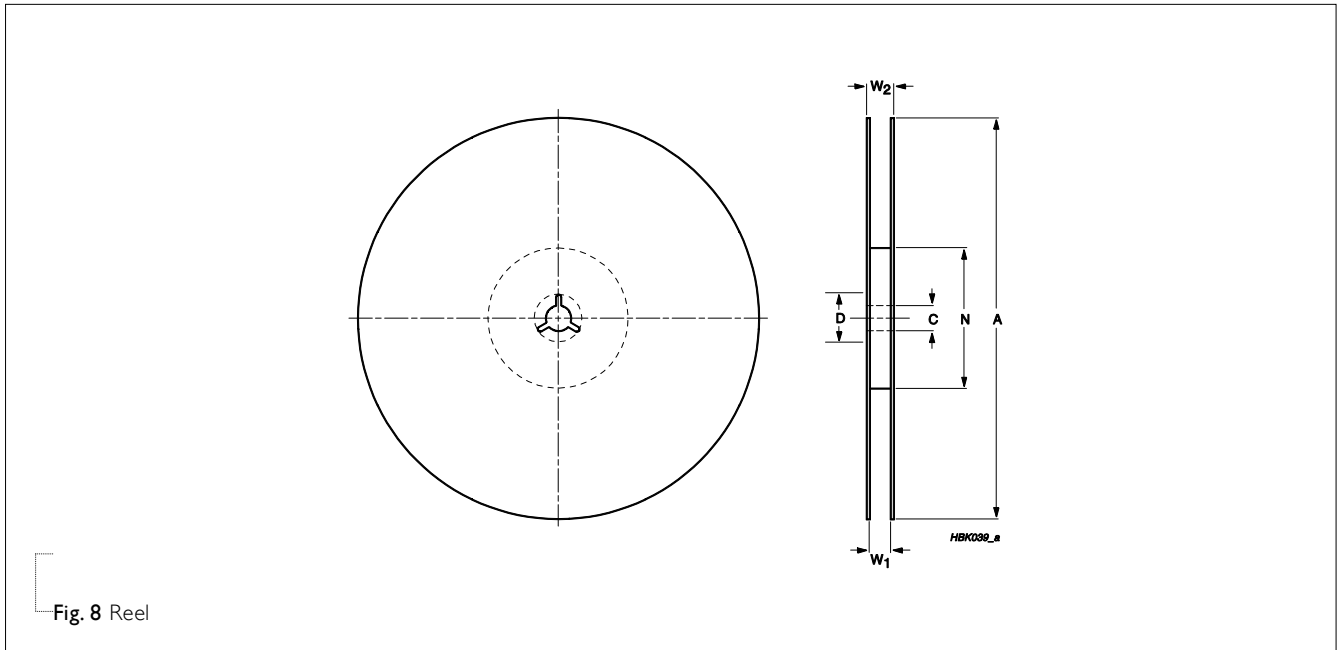

Fig. 8 Reel

Table 5 Dimensions of reel specification for relevant chip resistors size

SIZE	QUANTITY PER REEL	REEL SIZE		SYMBOL				Unit: mm	
		8 mm TAPE WIDE	12 mm TAPE WIDE	A	N	C	D	W <sub>1</sub>	W <sub>2</sub> MAX.
PR0805	5000	7" (Ø178 mm)	---	178.0±1.0	60.0+1/-0	13.20±0.5	17.70±0.5	8.4 +1/-0	12.4±0.5
PR1206	4000	7" (Ø178 mm)	--	178.0±1.0	60.0±0.5	13.20±0.5	17.70±0.5	9.0±0.3	12.0±0.5
PR2010	2000	-- (Ø178 mm)	7"	178.0±1.0	60.0±0.5	13.50±0.5	17.70±0.5	13.0±0.5	16.2±0.5
PR2512	4000	-- (Ø178 mm)	7"	178.0±1.0	60.0±0.5	13.50±0.5	17.70±0.5	13.0±0.5	16.2±0.5

**LEADER/TRAILER TAPE SPECIFICATION**

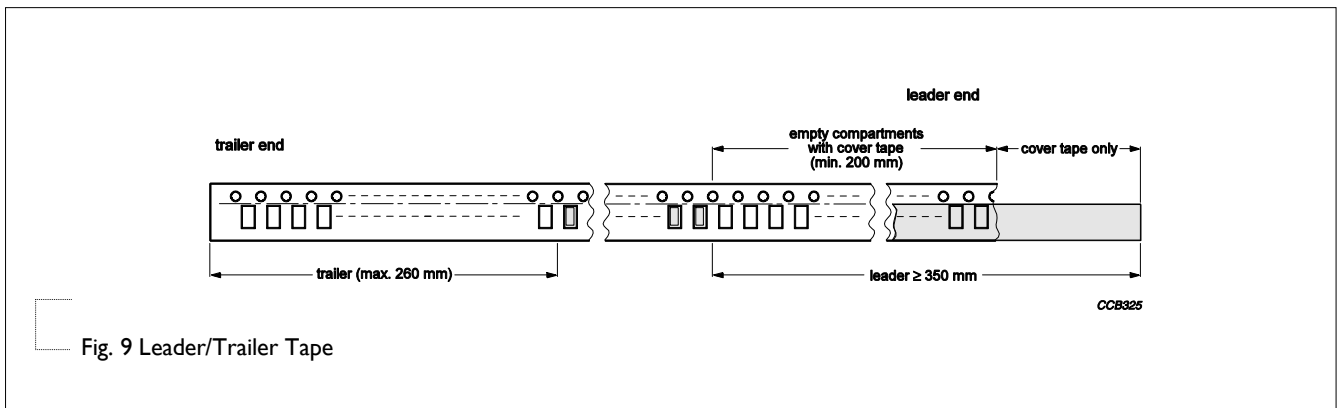

Fig. 9 Leader/Trailer Tape

**FOOTPRINT AND SOLDERING PROFILES**

For recommended soldering profiles, please refer to data sheet “Chip resistors mounting”.

**FOOTPRINT**

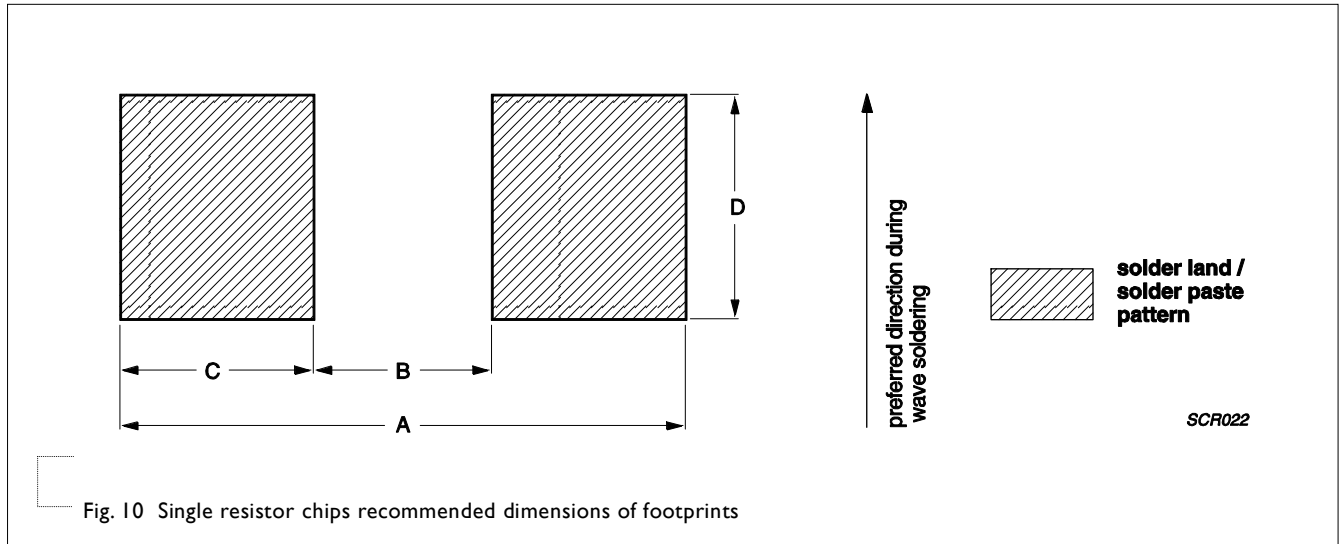

Fig. 10 Single resistor chips recommended dimensions of footprints

Table 6 Footprint dimensions

SIZE	RESISTANCE RANGE	POWER RATING	A	B	C	D	Unit: mm
PR0805	$3\text{m}\Omega \leq R \leq 50\text{ m}\Omega$	1/8W, 1/4W, 1/2W	4.26	0.66	1.80	2.18	
PR1206	$1\text{m}\Omega \leq R \leq 50\text{m}\Omega$	1/4W, 1/2W, 1W	4.20	1.00	1.60	2.18	
PR2010	$1\text{m}\Omega \leq R \leq 3\text{m}\Omega$	1/2W, 1W	7.00	1.22	2.89	2.92	
	$3\text{m}\Omega < R \leq 100\text{ m}\Omega$		6.99	2.41	2.29	2.92	
PR2512	$0.5\text{m}\Omega \leq R \leq 4\text{m}\Omega$	1W, 2W	7.37	1.27	3.05	3.68	
	$4\text{m}\Omega < R \leq 100\text{ m}\Omega$		7.40	3.18	2.11	3.68	
	$0.5\text{m}\Omega$		7.37	1.27	3.05	3.68	
PR2512	$0.5\text{m}\Omega < R < 3\text{m}\Omega$ , $4\text{m}\Omega < R \leq 10\text{ m}\Omega$	3W	7.38	3.00	2.19	3.68	
	$3\text{m}\Omega \leq R \leq 4\text{m}\Omega$		7.38	1.80	2.79	3.68	

**TESTS AND REQUIREMENTS**
**Table 8 Test condition, procedure and requirements**

TEST	TEST METHOD	PROCEDURE	REQUIREMENTS
Life/ Operational Life/ Endurance	MIL-STD-202G-method 108A	1,000 hours at 70±5 °C applied RCWV	±(1%+0.0005 Ω)
	IEC 60115-1 4.25.1	1.5 hours on, 0.5 hour off, still air required	
	JIS C 5202-7.10		
High Temperature Exposure/ Endurance at Upper Category Temperature	MIL-STD-202G-method 108A	1,000 hours at maximum operating temperature	±(1%+0.0005 Ω)
	IEC 60115-1 4.25.3	depending on specification, unpowered	
	JIS C 5202-7.11	No direct impingement of forced air to the parts Tolerances: 170±3 °C	
Moisture Resistance	MIL-STD-202G-method 106F	Each temperature / humidity cycle is defined at 8 hours (method 106F), 3 cycles / 24 hours for 10d with 25 °C / 65 °C 95% R.H, without steps 7a & 7b, unpowered  Parts mounted on test-boards, without condensation on parts  Measurement at 24±2 hours after test conclusion	±(0.5%+0.0005 Ω)
	IEC 60115-1 4.24.2		
Thermal Shock	MIL-STD-202G-method 107G	PR1206~PR2512 : -55/+155 °C PR0805 : -55/+125 °C  Note: Number of cycles required is 300. Maximum transfer time is 20 seconds. Dwell time is 15 minutes. Air – Air	±(0.5%+0.0005 Ω)
Short Time Overload	MIL-R-55342D-para 4.7.5	5 times of rated power for 5 seconds at room temperature	±(0.5%+0.0005 Ω) No visible damage
	IEC60115-1 4.13		
Board Flex/ Bending	IEC60115-1 4.33	Device mounted on PCB test board as described, only 1 board bending required	±(1%+0.0005 Ω) No visible damage
		Bending for 0805/1206/2010/2512: 2 mm	
		Holding time: minimum 60 seconds	
Humidity	IEC 60115-1 4.21	Steady state for 1000 hours at 40 °C / 95% R.H. RCWV applied for 1.5 hours on and 0.5 hour off	±(1%+0.0005Ω)

TEST	TEST METHOD	PROCEDURE	REQUIREMENTS
Solderability - Wetting	IPC/JEDECJ-STD-002B test B	Electrical Test not required	Well tinned ( $\geq 95\%$ covered)
	IEC 60068-2-58	Magnification 50X SMD conditions: 1 <sup>st</sup> step: method B, aging 4 hours at 155 °C dry heat 2 <sup>nd</sup> step: leadfree solder bath at 245 $\pm$ 3 °C Dipping time: 3 $\pm$ 0.5 seconds	No visible damage
- Leaching	IPC/JEDECJ-STD-002B test D IEC 60068-2-58	Leadfree solder, 260 °C, 30 seconds immersion time	No visible damage
- Resistance to Soldering Heat	MIL-STD-202G-method 210F	Condition B, no pre-heat of samples	$\pm(0.5\%+0.0005 \Omega)$
	IEC 60068-2-58	Leadfree solder, 260 °C, 10 seconds immersion time Procedure 2 for SMD: devices fluxed and cleaned with isopropanol	No visible damage



REVISION HISTORY

REVISION	DATE	CHANGE NOTIFICATION	DESCRIPTION
Version 0	Aug. 22, 2014	-	- New datasheet for current sensor - low TCR PR series sizes of 0805/1206/2010/2512, 1% and 5% with lead-free terminations





*“Yageo reserves all the rights for revising the content of this datasheet without further notification, as long as the products itself are unchanged. Any product change will be announced by PCN.”*

## Looking for pricing, stock, or lifecycle information?

Click below to explore more details on WIN SOURCE:

-  [View PR2512FKG070R001L on WIN SOURCE](#)
-  [Yageo Information](#)

## Optimize Your Supply Chain with WIN SOURCE Solutions

-  Global Sourcing Solution
-  Obsolete Management
-  Cost Control Management
-  Shortage Management
-  Alternative Solution
-  Excess Inventory Management