

LED Drivers for LCD Backlights

White LED Driver for large LCD Panels (DCDC Converter type)



BD9394FP, BD9394EFV

● **General Description**

BD9394FP, BD9394EFV is a high efficiency driver for white LEDs and designed for large LCDs. This IC is built-in a boost DCDC converters that employ an array of LEDs as the light source. BD9394FP, BD9394EFV has some protect function against fault conditions, such as the over-voltage protection (OVP), the over current limit protection of DCDC (OCP), the short circuit protection (SCP), the open detection of LED string. Therefore BD9394FP, BD9394EFV is available for the fail-safe design over a wide range output voltage.

● **Key Specification**

- Operating power supply voltage range: 9.0V to 35.0V
- LED minimum current 30mA
- LED maximum current: 150mA
- Oscillator frequency: 150kHz (RT=100kΩ)
- Operating Current: 4.5mA (Typ.)
- Operating temperature range: -40°C to +85°C

● **Applications**

TV, Computer Display, Notebook, LCD Backlighting

● **Package**

HSOP20
HTSSOP-B24

W(Typ.) x D(Typ.) x H(Max.)
14.90mm x 7.80mm x 2.10mm
7.80mm x 7.60mm x 1.00mm

● **Features**

- 4ch LED constant current driver and DC/DC converter
- Maximum LED Current: 150mA
- LED Feedback Voltage: 0.37V (@NADIM=2.62V), so lower heat. Adjustable Feed Back Voltage by following LED Current setting.
- ±2% LED current accuracy (NADIM=2.62V, when each LED is set to 100mA)
- Analog current (Linear) dimming at NADIM pin
- LED pin rating 60V
- Individual detection and individual LED OFF for both open and short circuits
- Built-in ISET pin short-circuit protection circuit
- Set Soft-Start time by external capacitor.
- FET's Gate (N pin) is driven by 5.8V swing
- Built-in Vout discharge circuit for shutdown
- Built-in Vout overvoltage protection (OVP) / reduced voltage protection (SCP) circuit
- Adjustable LED Short Protection Voltage by LSP terminal
- HSOP20, HTSSOP-B24 package with high heat radiation efficiency

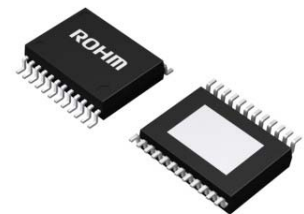

Fig.1(a) HSOP20

Fig.1(b) HTSSOP-B24

● **Typical Application Circuit (4 light with PWM)**

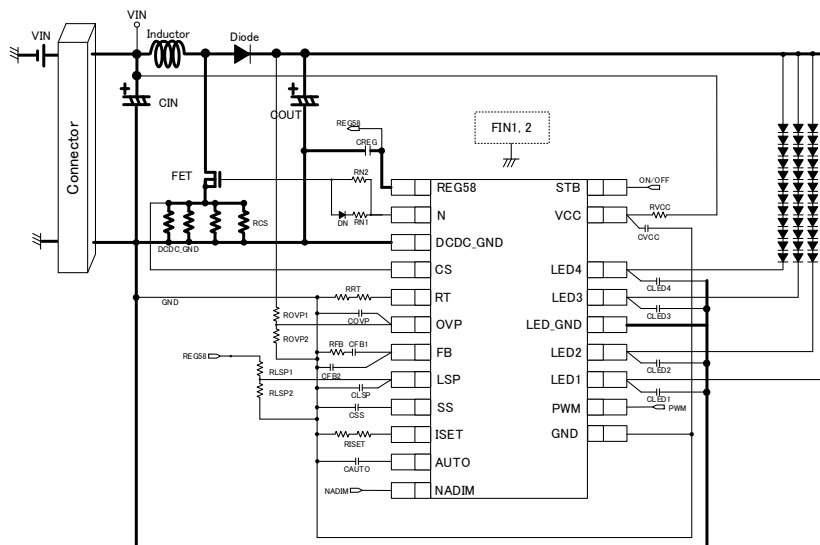

Fig.2 Typical Application Circuit

● Absolute maximum ratings (Ta=25°C)

Parameter	Symbol	Ratings	Unit
Power supply voltage	VCC	36	V
STB, NADIM, OVP, PWM terminal voltage	STB, NADIM, OVP, PWM	VCC	V
LED1 to 4 terminal voltage	LED1~4	60	V
AUTO, REG58, CS, N, LSP, ISET, SS, FB, RT terminal voltage	AUTO, REG58, CS, N, LSP, ISET, SS, FB, RT	7	V
Power dissipation 1(HSOP20)	Pd1	2.18 *1	W
Power dissipation 2(HTSSOP-B24)	Pd2	4.00 *2	W
Operating temperature range	Topr	-40~+85	°C
Storage temperature range	Tstg	-55~+150	°C
Junction temperature	Tjmax	150	°C

*1 Ta = 25°C or more, diminished at -17.4mW/°C in the case of HSOP20 (when 4-layer / 70.0 mm x 70.0 mm x 1.6 mm board is mounted)

*2 Ta = 25°C or more, diminished at -32.0mW/°C in the case of HTSSOP-B24 (when 4-layer / 70.0 mm x 70.0 mm x 1.6 mm board is mounted)

● Operating Ratings (Ta = 25°C)

Parameter	Symbol	Limits	Unit
VCC supply voltage	VCC	9.0~35.0	V
Min. output current of LED1 to 4	ILED_MIN	30	mA *1
Max. output current of LED1 to 4	ILED_MAX	150	mA *1,2
Min. output current of LED1 to 4	VNADIM1	0~5.0 *3	V
Max. output current of LED1 to 4	VNADIM2	7.0~35.0	V
DC/DC oscillation frequency	VLSP	0.8~3.0	V
DC/DC oscillation frequency	Fsw	100~800	kHz
Min. on-duty time for PWM light modulation	PWM_MIN	30	us

*1 The amount of current per channel.

*2 If LED makes significant variations in its reference voltage, the driver will increase power dissipation, resulting in a rise in package temperature. To avoid this problem, design the board with thorough consideration given to heat radiation measures.

*3 The range which the LED current changes with linearity is from 1.5V to 5V.

● Pin Configuration

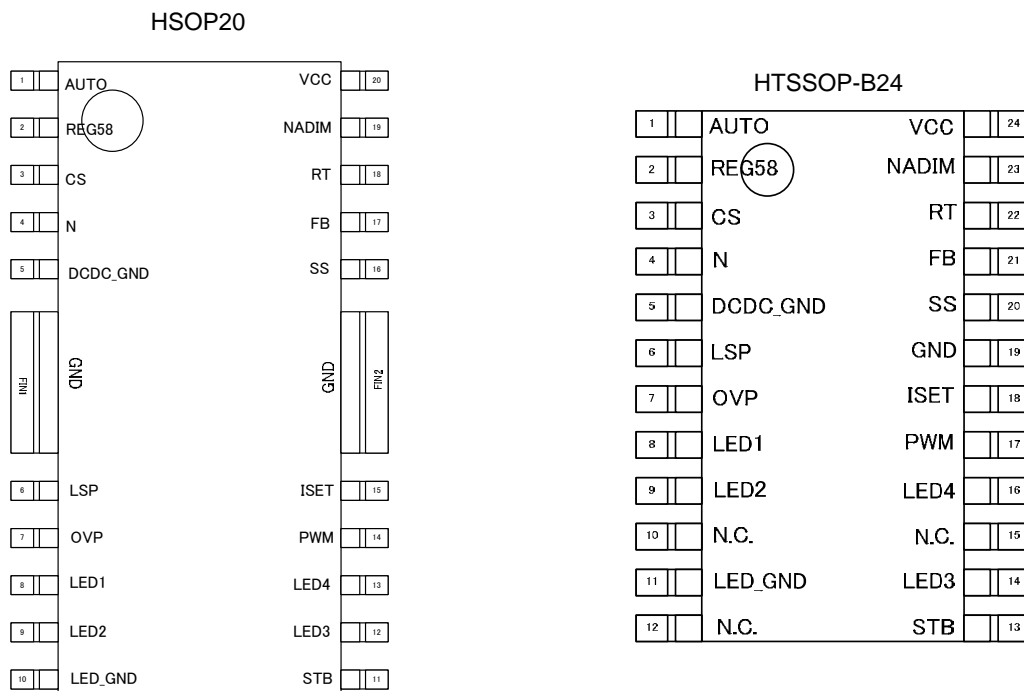

Fig.3 Pin Configuration

●Marking diagram and physical dimension

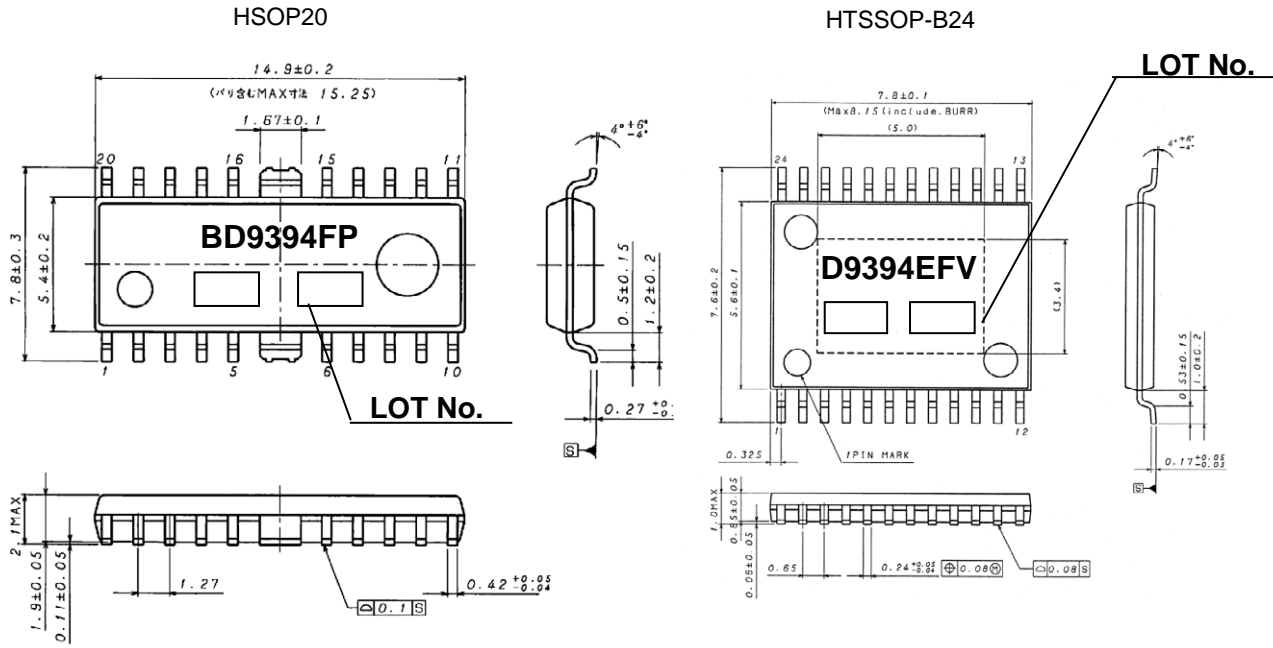

Fig.4 Physical Dimension

●Electrical Characteristics (Unless otherwise noted, Ta = 25°C, VCC=24V)

Parameter	Symbol	Limit			Unit	Condition
		Min.	Typ.	Max.		
[Whole Device]						
Circuit current while in operation	ICC	-	4.5	9	mA	STB=3V,PWM=3V,RT=100kΩ
Circuit current while in standby	ISTB	-	40	80	μA	STB=0V
[REG58 Block]						
REG58 Output Voltage	REG58	5.742	5.8	5.858	V	IO=0mA
Soft start completion voltage	IREG58	15	-	-	mA	
[UVLO Block]						
UVLO release voltage	VUVLO_VCC	6.5	7.5	8.5	V	VCC=SWEEP UP
UVLO hysteresis voltage	VUHYS_VCC	150	300	600	mV	VCC=SWEEP DOWN
[DC/DC Block]						
Error amp. Reference voltage	VLED	0.35	0.37	0.39	V	ISET=75kΩ, NADIM=2.62V
Oscillation frequency	fsw	142.5	150.0	157.5	kHz	RT=100kohm
Max. duty cycle per output of N pin	DMAX	83	90	97	%	RT=100kohm
On resistance on N pin source side	RONH	-	4	8	Ω	ION=-10mA
On resistance on N pin sink side	RONL	-	3	6	Ω	ION=10mA
SS pin source current	ISSSO	-4	-2	-1	uA	VSS=2V
Soft start completion voltage	VSS_END	3.3	3.7	4.1	V	SS=SWEEP UP
FB sink current	IFBSINK	50	100	150	μA	LED=2.0V, VFB=1.0V
FB source current	IFBSOURCE	-150	-100	-50	μA	LED=0V, VFB=1.0V
Over current detection voltage	VCS	0.40	0.45	0.50	V	CS=SWEEP UP

● **Electrical Characteristics** (Unless otherwise noted, Ta = 25°C, VCC=24V)

Parameter	Symbol	Limit			Unit	Condition
		Min.	Typ.	Max.		
[DC/DC Protection Block]						
Overvoltage protection detection voltage	VOVP	2.7	3.00	3.3	V	VOVP=SWEEP UP
Overvoltage protection detection hysteresis voltage	VOVP_HYS	50	100	200	mV	VOVP=SWEEP DOWN
Short circuit protection detection voltage	VSCP	0.04	0.10	0.25	V	VOVP=SWEEP DOWN
[LED Driver Block]						
LED pin current accuracy 1	dILED1	-2	-	2	%	I _{LED} =100mA, (V _{NADIM} =2.62V,R _{ISSET} =75kΩ)
LED pin current accuracy 2	dILED2	-3	-	3	%	I _{LED} =100mA, (V _{NADIM} =7V,R _{ISSET} =75kΩ)
LED pin Leakage Current	ILLED	-2.5	-	2.5	μA	V _{LED} =60V
LED open detection voltage	VOPEN	0.05	0.2	0.285	V	V _{LED} =SWEEP DOWN
LED short detection voltage	VSHORT	4	5	6	V	V _{LED} =SWEEP UP, V _{LSP} =OPEN
LSP pin resistive divider upper side resistance	RULSP	1000	2000	3000	kΩ	V _{LSP} =0V
LSP pin resistive divider lower side resistance	RDLS	500	1000	1500	kΩ	V _{LSP} =3V
NADIM pin Input Current	ILNADIM	-2.5	-	2.5	μA	V _{NADIM} =5V
[STB Block]						
STB pin high-level voltage	STBH	2	-	35	V	STB=SWEEP UP
STB pin low-level voltage	STBL	-0.3	-	0.8	V	STB=SWEEP DOWN
STB pin pull-down resistance	RSTB	500	1000	1500	kΩ	V _{STB} =3.0V
[PWM Block]						
PWM pin high-level voltage	PWMH	2	-	35	V	PWM=SWEEP UP
PWM pin low-level voltage	PWML	-0.3	-	0.8	V	PWM= SWEEP DOWN
PWM pin pull-down resistance	RPWM	180	300	420	kΩ	PWM=3.0V
[Failure Indication Block (Open Drain)]						
AUTO pin source current	IAUTO	-2	-1	-0.5	μA	V _{AUTO} =2V
AUTO pin Detection Voltage	VAUTO	3.6	4.0	4.4	V	V _{AUTO} =SWEEP UP
Abnormal Detection Timer	tCP		20		ms	R _T =75kΩ

● Pin Descriptions (BD9394FP)

Pin No	Pin Name	In/Out	Function	Rating [V]
1	AUTO	Out	Auto-restart time setting pin	-0.3 ~ 7
2	REG58	Out	Power supply for N pin	-0.3 ~ 7
3	CS	In	DC/DC output current detection and OCP detection pin	-0.3 ~ 7
4	N	In	DC/DC switching output pin	-0.3 ~ 7
5	DCDC_GND	-	Power GND pin	-
FIN1	GND	-	Analog GND pin	-
6	LSP	In	LED Short detection voltage setting resistor connection pin	-0.3 ~ 7
7	OVP	In	Overvoltage protection detection pin	-0.3 ~ 36
8	LED1	Out	Output pin 1 for LED	-0.3 ~ 60
9	LED2	Out	Output pin 2 for LED	-0.3 ~ 60
10	LED_GND	-	Ground pin for LED	-
11	STB	In	Enable pin	-0.3 ~ 36
12	LED3	Out	Output pin 3 for LED	-0.3 ~ 60
13	LED4	Out	Output pin 4 for LED	-0.3 ~ 60
14	PWM	In	External PWM light modulation signal input pin for LED1-4	-0.3 ~ 36
15	ISET	Out	LED current setting resistor connection pin	-0.3 ~ 7
FIN2	GND	-	Analog GND pin	-
16	SS	Out	Soft start pin / LED protection masking time setting pin.	-0.3 ~ 7
17	FB	In/Out	Error amp output pin	-0.3 ~ 7
18	RT	Out	DC/DC drive frequency setting resistor connection pin.	-0.3 ~ 7
19	NADIM	In	Analog dimming DC voltage input pin	-0.3 ~ 36
20	VCC	In	Power supply pin	-0.3 ~ 36

● Pin Descriptions (BD9394EFV)

Pin No	Pin Name	In/Out	Function	Rating [V]
1	AUTO	Out	Auto-restart time setting pin	-0.3 ~ 7
2	REG58	Out	Power supply for N pin	-0.3 ~ 7
3	CS	In	DC/DC output current detection and OCP detection pin	-0.3 ~ 7
4	N	In	DC/DC switching output pin	-0.3 ~ 7
5	DCDC_GND	-	Power GND pin	-
6	LSP	In	LED Short detection voltage setting resistor connection pin	-0.3 ~ 7
7	OVP	In	Overvoltage protection detection pin	-0.3 ~ 36
8	LED1	Out	Output pin 1 for LED	-0.3 ~ 60
9	LED2	Out	Output pin 2 for LED	-0.3 ~ 60
10	N.C.	-	Unconnected pin.	-
11	LED_GND	-	Ground pin for LED	-
12	N.C.	-	Overvoltage protection detection pin.	-
13	STB	In	Enable pin	-0.3 ~ 36
14	LED3	Out	Output pin 3 for LED	-0.3 ~ 60
15	N.C.	-	DC/DC switching output pin.	-
16	LED4	Out	Output pin 4 for LED	-0.3 ~ 60
17	PWM	In	External PWM light modulation signal input pin for LED1-4	-0.3 ~ 36
18	ISET	Out	LED current setting resistor connection pin	-0.3 ~ 7
19	GND	-	Analog GND pin	-
20	SS	Out	Soft start pin / LED protection masking time setting pin.	-0.3 ~ 7
21	FB	In/Out	Error amp output pin	-0.3 ~ 7
22	RT	Out	DC/DC drive frequency setting resistor connection pin.	-0.3 ~ 7
23	NADIM	In	Analog dimming DC voltage input pin	-0.3 ~ 36
24	GND	-	Ground pin for analog block.	-

● Pin ESD Type

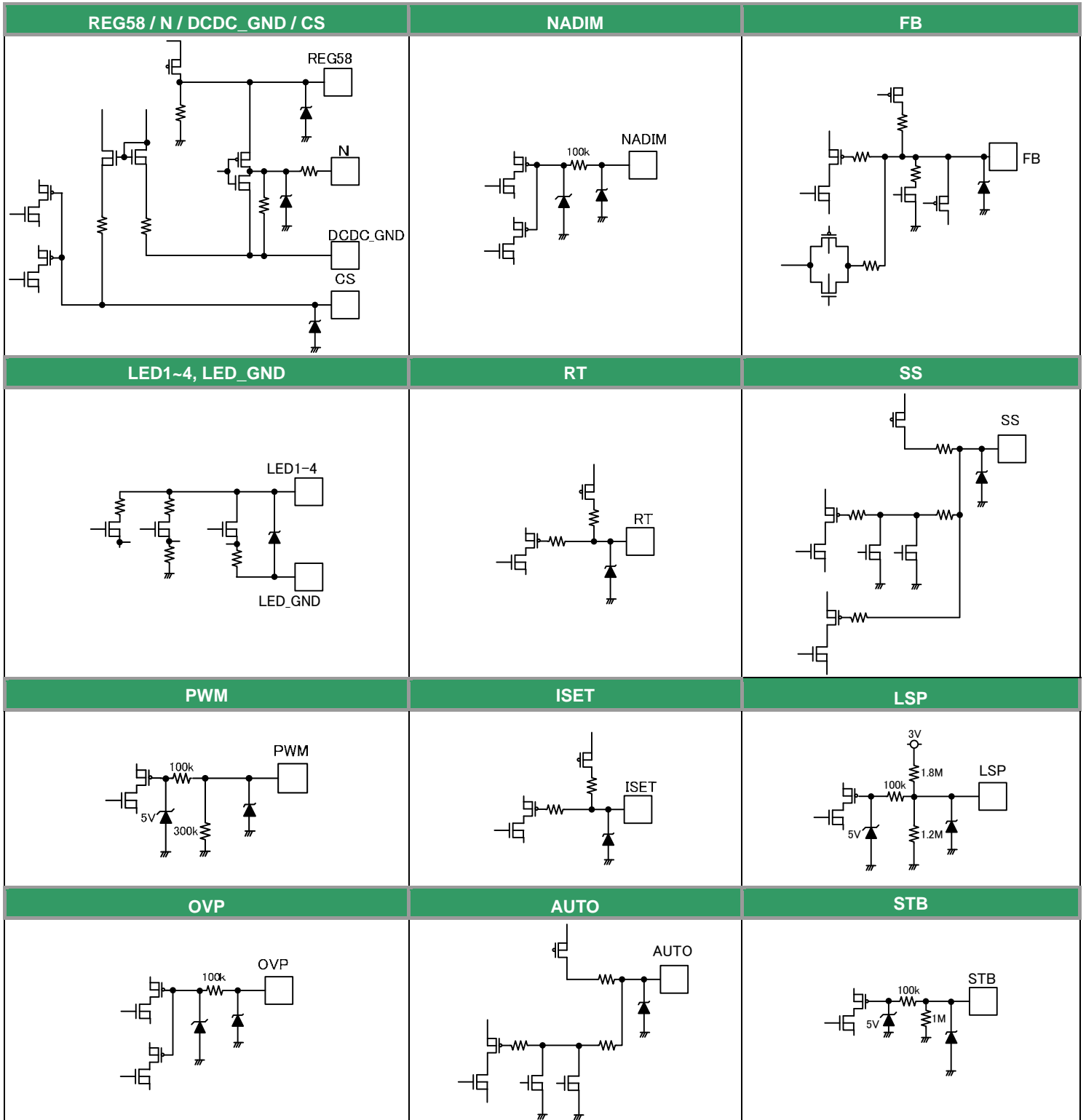

Fig. 5 Pin ESD Type

●Block Diagram

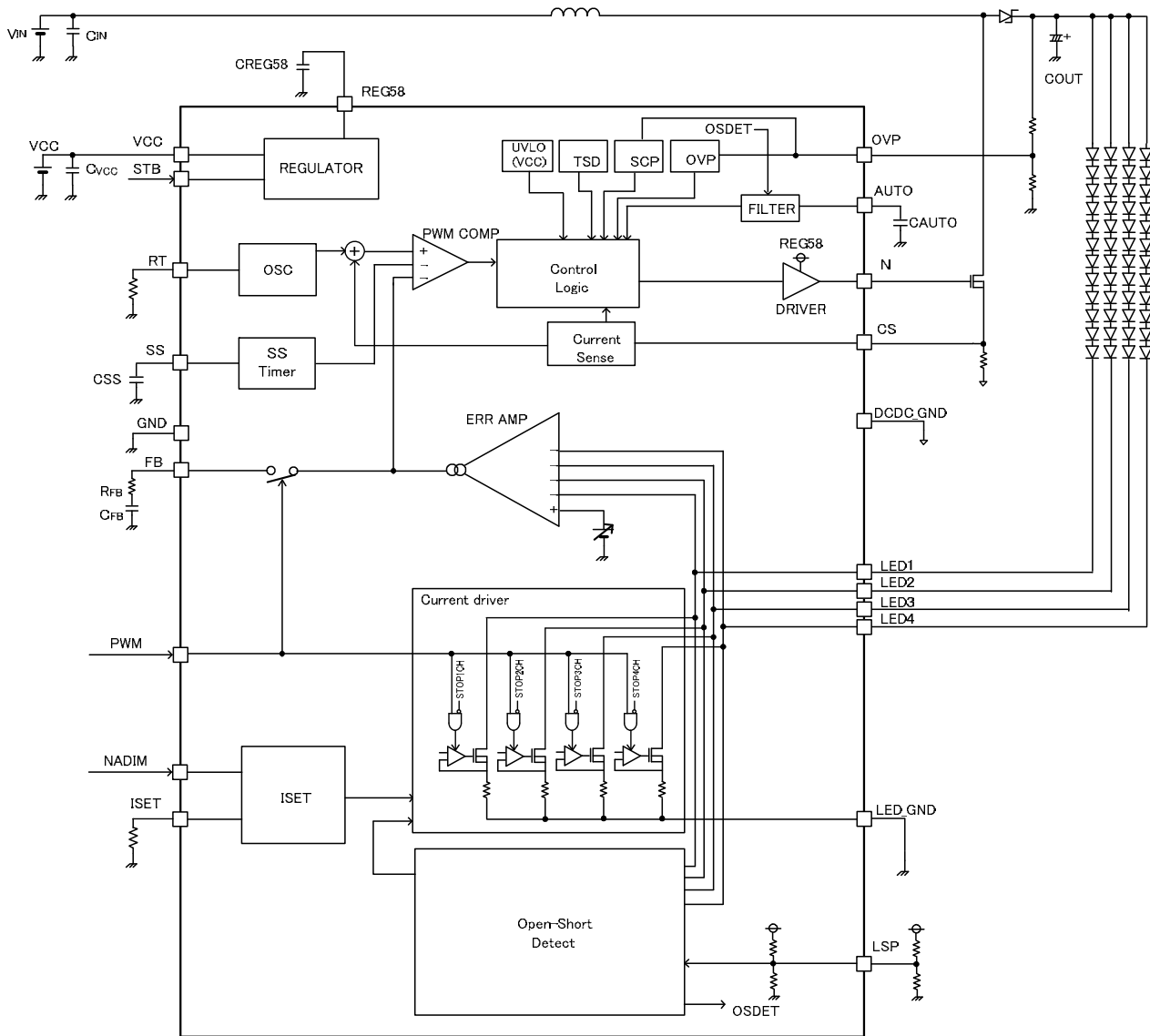

Fig. 6 Block Diagram

● Typical Performance Curve

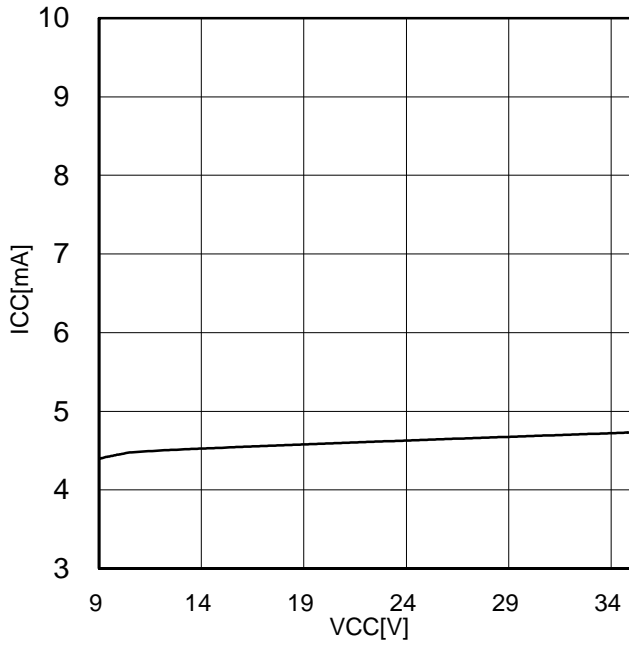

Fig.7 Operating Current (ICC) [mA] vs. VCC[V]

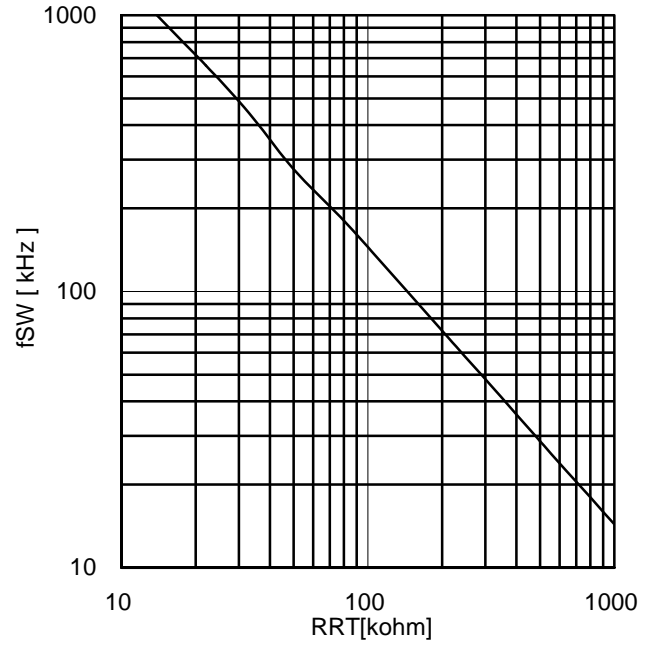

Fig.8 N Frequency [MHz] vs. R_RT [MΩ]

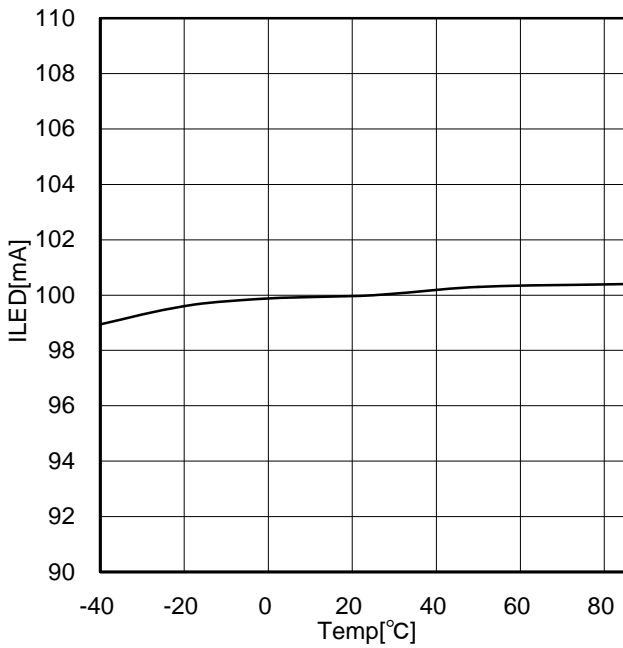

Fig.9 LED Current (ILED) [mA] vs. Temp [°C]

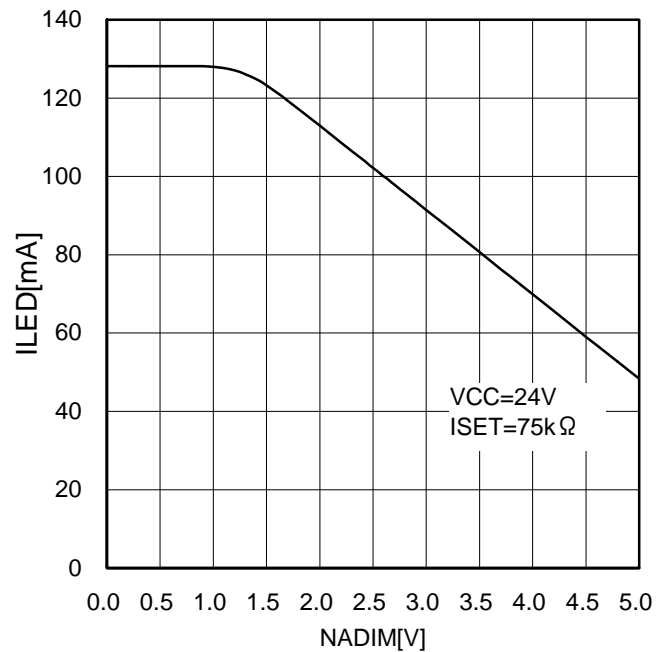

Fig.10 LED Current (ILED) [mA] vs. NADIM [V]

● Pin Function

○ AUTO (HSOP20:1pin / HTSSOP-B24:1pin)

This sets up time till auto-restart time from the point of abnormal detection. Having 1uA constant current charge at external capacitor connected to AUTO pin, it will start again when it becomes over 4.0V (The auto pin is shorted to GND, this IC's protection function operates latched off mode).

○ Auto-restart period vs. AUTO capacitance (Ideal)

$$T_{AUTO} = \frac{4.0[V] \times C_{AUTO}}{1.0 \times 10^{-6}[A]} = 4.0 \times 10^6 \times C_{AUTO} [\text{sec}]$$

○ REG58 (HSOP20:2pin / HTSSOP-B24:2pin)

The REG58 pin is used in the DC/DC converter driver block to output 5.8V power. The maximum operating current is 15mA. Using the REG58 pin at a current higher than 15mA can affect the N pin output pulse, causing the IC to malfunction and leading to heat generation of the IC itself. To avoid this problem, it is recommended to make load setting to the minimum level.

Please place the ceramic capacitor connected to REG58 pin (2.2uF~10uF) closest to REG58-GND pin.

○ CS (HSOP20:3pin / HTSSOP-B24:3pin)

The CS pin has the following two functions:

1. DC/DC current mode current feedback function

Current flowing through the inductor is converted into voltage by the current sensing resistor RCS connected to the CS pin and this voltage is compared with voltage set with the error amplifier to control the DC/DC output voltage.

2. Inductor current limit function

The CS pin also incorporates the over current protection (OCP) function. If the CS pin voltage reaches 0.45V (Typ.) or more, switching operation will be forcedly stopped.

○ ON (HSOP20:4pin / HTSSOP-B24:4pin)

The N pin is used to output power to the external NMOS gate driver for the DC/DC converter in the amplitude range of approx. 0 to REG58. ON resistances is 4.0Ω (typ.) in source (H side), 3.0Ω (typ.) in sink (L side).

Frequency setting can be made with a resistor connected to the RT pin. For details of frequency setting, refer to the description of the RT pin.

○ CDC_GND (HSOP20:5pin / HTSSOP-B24:5pin)

The PGND pin is a power ground pin for the driver block of the output pin N.

○ GND (HSOP20:FIN1, FIN2 / HTSSOP-B24:19pin)

The GND pin is an internal analog circuit ground of the IC.

○ LSP (HSOP20:6pin / HTSSOP-B24:6pin)

Terminal which sets LED SHORT detection voltage; the SHORT detection voltage is in a proportional relationship to LSP set voltage and is set by the following equation:

$$LED_{SHORT} = 5 \times VLSP [V]$$

LED_{SHORT}: LED detection voltage, VLSP: LSP setting voltage

LSP setting voltage should be made in the range of 0.8 to 3.0V. Set at 5 V (typ.) when LSP = OPEN.

OOVP (HSOP20:7pin / HTSSOP-B24:7pin)

The OVP pin is an input pin for over-voltage protection and short circuit protection of DC/DC output voltage. If over-voltage is detected, the OVP pin will stop the DC/DC converter conducting step-up operation. When the short circuit protection (SCP) function is activated, the DC/DC converter will stop operation, and then the timer will start counting. When the timer completes counting the preset period of time, the LED drivers are stopped.

The OVP pin is of the high impedance type and involves no pull-down resistor, resulting in unstable potential in the open-circuited state. To avoid this problem, be sure to make input voltage setting with the use of a resistive divider or otherwise.

OLED1 – LED4 (HSOP20:8,9,12,13pin / HTSSOP-B24:8,9,14,16pin)

The LED1 to 4 pins are used to output constant current to LED drivers. Current value setting can be made by connecting a resistor to the ISET pin.

For the current value setting procedure, refer to the description of "ISET pin".

If any of the LED pins is put in an erroneous state (e.g. short circuit mode, open circuit mode, or ground short circuit mode), the relevant protection function will be activated.

OLED_GND (HSOP20:10pin / HTSSOP-B24:11pin)

The LED_GND pin is a power ground pin used for the LED driver block.

OSTB (HSOP20:11pin / HTSSOP-B24:13pin)

The STB pin is used to make setting of turning ON and OFF the IC and allowed for use to reset the IC from shutdown.

Note: The IC state is switched (i.e., the IC is switched between ON and OFF state) according to voltages input in the STB pin. Avoid using the STB pin between two states (0.8 to 2.0V).

OPWM (HSOP20:14pin / HTSSOP-B24:17pin)

The PWM pin is used to turn ON and OFF LED drivers. Light can be modulated by changing the duty cycle through the direct input of a PWM light modulation signal

The high and low voltage levels of PWM pin is as listed in the table below:

State	PWM Voltage
LED ON 状態	PWM= 2.0V~35V
LED OFF 状態	PWM= -0.3V~0.8V

OISET (HSOP20:15pin / HTSSOP-B24:18pin)

The ISET pin is an output current setting resistor. Output current ILED varies in inverse proportion to resistance.

The relation between output current ILED and the resistance of ISET pin connection resistor RISET is given by the following equation:

$$I_{LED} [mA] = \frac{5000}{R_{ISET} [k\Omega]} \times \frac{7.12 - V_{NADIM} [V]}{3} \quad (NADIM=0\sim 5V)$$

$$I_{LED} [mA] = \frac{7500}{R_{ISET} [k\Omega]} \quad (NADIM>7V\sim 35V)$$

Output current setting should be made in the range of 30 to 150mA.

It prepares automatically to suitable LED feedback voltage that can output LED current set by ISET pin.

In short LED feedback voltage is dropped when the LED current is small and the IC heating is held automatically.

In case of a large current is needed, raise the LED pin feedback voltage. And it adjusts automatically to LED pin voltage that can be flow large LED current.

The calculation is as below.

$$V_{LED} = 3.7 \times I_{LED} [A] [V]$$

The LED feedback voltage (VLED) is clamped to 0.3V (typ.) when the LED current (ILED) is less than 81.1mA.

NADIM input range is from 0V to 5V. And the range which the LED currents change with linearity is from 1.5V to 5.0V.

When it reaches under $V_{ISET} \times 0.90V$ (typ), the LED current is off to prevent from passing a large current to the LED pin when the RISET is shorted and the ISET pin is shorted to the GND. And as the ISET pin returns to a normal state, the LED current returns.

OSS (HSOP20:16pin / HTSSOP-B24:20pin)

The SS pin is used to make setting of soft start time and duty for soft start. It performs constant current charge of 2.0 uA to the external capacitor connected with SS terminal, which enables soft-start of DC/DC converter. Since the LED protection function (OPEN/SHORT detection) works when the SS terminal voltage reaches 3.7 V (typ.) or higher, it must be set to bring stability to conditions such as DC/DC output voltage and LED constant current drive operation, etc. before the voltage of 3.7 V is detected.

OFB (HSOP20:17pin / HTSSOP-B24:21pin)

The FB pin is an output pin used for DC/DC current mode control error amplifier. In other words, the FB pin detects the voltages of LED pins (1 to 4) and controls inductor current so that the pin voltage of the LED located in the row with the highest Vf will come to 0.37V (NADIM=(2.62)V, ILED=100mA). As a result, the pin voltages of other LEDs become higher by Vf variation. After completion of soft start, the FB pin is put into the high-impedance state with the PWM signal being in the low state, thus maintaining the FB voltage.

ORT (HSOP20:18pin / HTSSOP-B24:22pin)

The RT pin is used to connect a DC/DC frequency setting resistor. DC/DC drive frequency is determined by connecting the RT resistor.

ODrive frequency vs. RT resistance (Ideal)

$$R_{RT} = \frac{15000}{f_{sw} [kHz]} [k\Omega]$$

When RT is 100kΩ, Fsw is 150kHz(typ.). However, drive frequency setting should be made in the range of 100 kHz to 800 kHz.

ONADIM (HSOP20:19pin / HTSSOP-B24:23pin)

NADIM pin is for analog dimming. Output current is proportionality with input voltage (negative). Basically, NADIM pin assumes the voltage inputted externally using high accuracy of resistive divider and etc., IC internally is in OPEN (High impedance) condition.

Please be sure to apply externally for Resistive divider and etc. from REG58 output. Cannot use in an OPEN condition.

OVCC (HSOP20:20pin / HTSSOP-B24:24pin)

The VCC pin is used to supply power for the IC in the range of 9 to 35V.

If the VCC pin voltage reaches 7.5V (Typ.) or more, the IC will initiate operation. If it reaches 7.2V (Typ.) or less, the IC will be shut down.

● Startup operation and soft start (SS) capacitance setting

The following section describes the sequence for the startup of this IC.

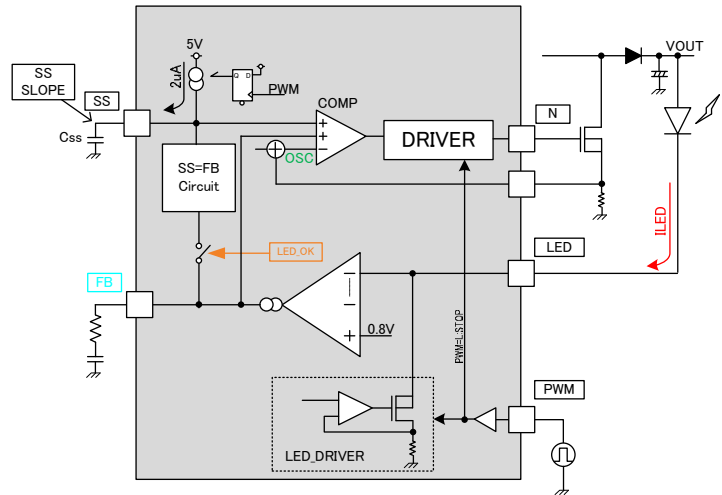
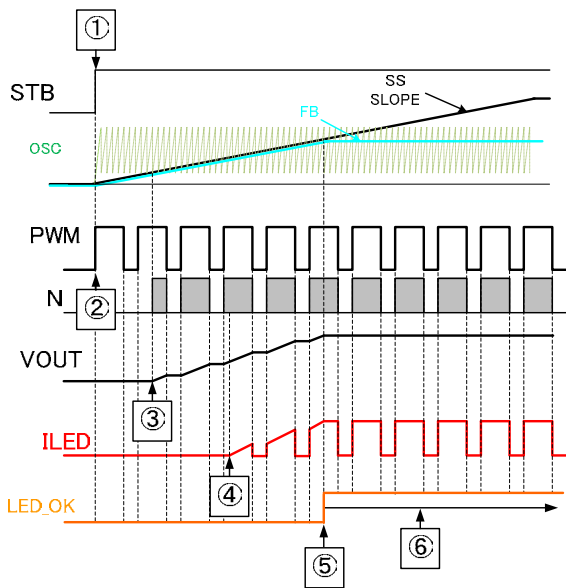

○ Description of startup sequence

- (1) Set the STB and PWM pin to "ON".
- (2) Set all systems to "ON", SS charge will be initiated.
At this time, a circuit in which SS pin voltage for soft start becomes equal to FB pin voltage operates to equalize the FB pin and SS pin voltages regardless of whether the PWM pin is set to Low or High level.
- (3) Since the FB pin and SS pin reach the lower limit of the internal sawtooth wave of the IC, the DC/DC converter operates to start VOUT voltage rising.
- (4) The Vout voltage continues rising to reach a voltage at which LED current starts flowing.
- (5) When the LED current reaches the set amount of current, isolate the FB circuit from the SS circuit. With this, the startup operation is completed.
- (6) After that, conduct normal operation following the feedback operation sequence with the LED pins.
If the SS pin voltage reaches 3.7V or more, the LED protection function will be activated to forcibly end the SS and FB equalizing circuit.

○ OSS capacitance setting procedure

As aforementioned, this IC stops DC/DC converter when the PWM pin is set to Low level and conducts step-up operation only in the section in which the PWM pin is maintained at High level. Consequently, setting the PWM duty cycle to the minimum will extend the startup time. The startup time also varies with application settings of output capacitance, LED current, output voltage, and others.

Startup time at minimum duty cycle can be approximated according to the following method:

Make measurement of VOUT startup time with a 100% duty cycle, first. Take this value as "Trise100".

The startup time "Trise_min" for the relevant application with the minimum duty cycle is given by the following equation.

$$T_{rise_min} = \frac{T_{rise_100}[Sec]}{Min_Duty[ratio]} [Sec]$$

However, since this calculation method is just for approximation, use it only as a guide.

Make setting of time during which the SS pin voltage reaches the FB pin voltage longer than this startup time.

Assuming that the FB pin voltage is VFB, the time is given by the following equation:

$$T_{ss} = \frac{C_{ss}[F] \times V_{FB}[V]}{2[\mu A]} [Sec]$$

As a result, it is recommended to make SS capacitance setting so that "Tss" will be greater than "Trise_min"

○ About unused LED terminal automatic detecting function

This IC is detected automatically that it is an unused channel by assuming the LED terminal to be OPEN at starting. It explains the sequence.

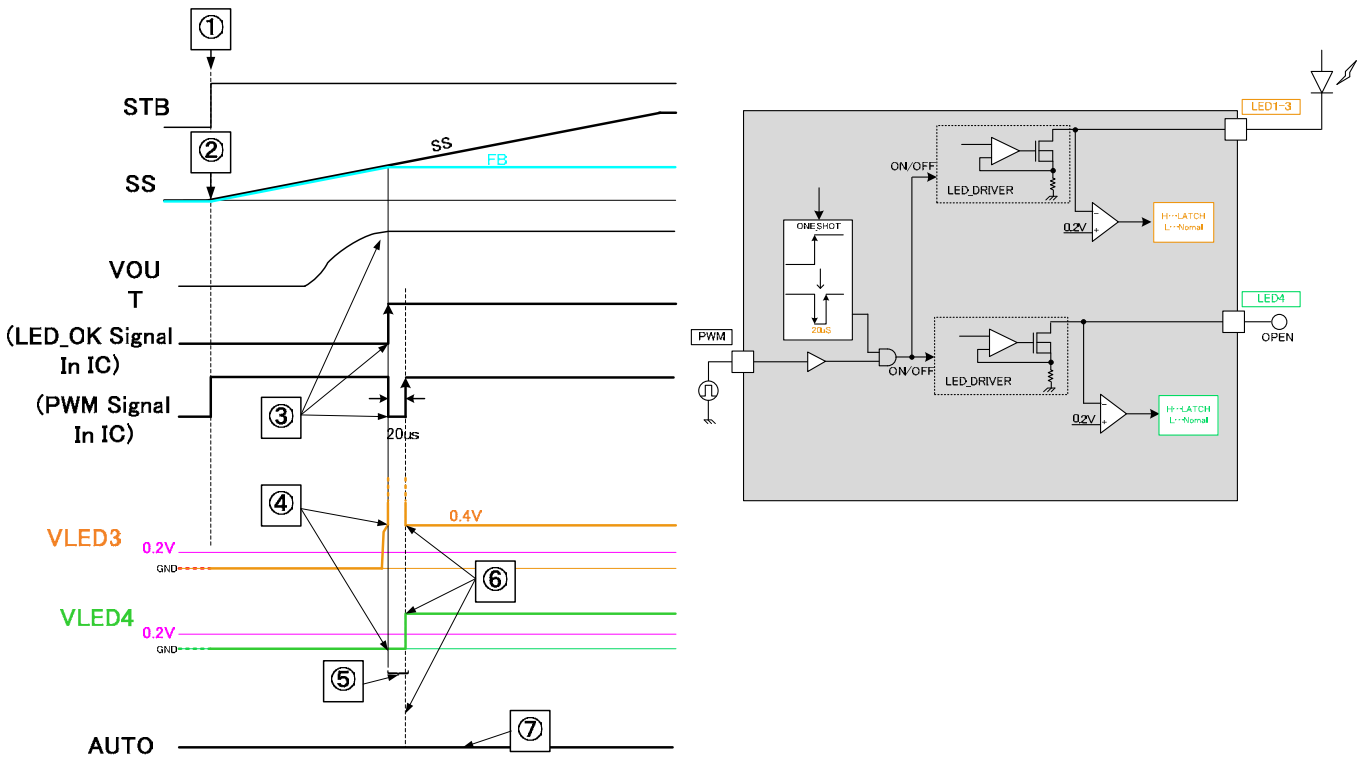

Sequence;

- ① STB=ON
- ② All systems are ON at initial timing of PWM=H. SS starts charging.
- ③ When the output voltage is boosted enough, and enough current flows through the LED, LED_OK signal is switched in the IC. PWM=L from the Rise timing of this signal for about 20μs
- ④ During this PWM=L period, LED pins with LED connections' output voltage becomes 0.2V and above, where as unused LED pins are below 0.2V.
- ⑤ During this time, determination on whether the LED pins are 0.2V above/below is done.
- ⑥ After the determination, unused LED pins are pulled up to 5V.
- ⑦ The AUTO signal remains "L" level.

In addition, automatic determination of the OPEN decision will only be in SS range, therefore, please set the application so that the step-up/boost be completed before $SS > 3.7V$.

●LED current setting

Setting of LED output current "ILED" can be made by connecting a resistor R_{ISET} to the ISET pin.

OR_{ISET} vs. I_{LED} current relation equation

$$R_{ISET} = \frac{7500}{I_{LED} [mA]} \quad [k\Omega] \quad (\text{NADIM}=7\sim 35V)$$

However, LED current setting should be made in the range of 30mA to 150mA.

[Setting example]

To set I_{LED} current to 100mA, R_{ISET} resistance is given by the following equation:

$$R_{ISET} = \frac{7500}{I_{LED} [mA]} = \frac{7500}{100 [mA]} = 75 \quad [k\Omega]$$

●DC/DC converter drive frequency setting

DC/DC converter drive frequency is determined by making R_{RT} resistance setting.

ODrive frequency vs. R_{RT} resistance (ideal) relation equation

$$R_{RT} = \frac{15000}{f_{sw} [kHz]} \quad [k\Omega]$$

where f_{sw} = DC/DC converter oscillation frequency [kHz]

This equation has become an ideal equation without any correction item included.

For accurate frequency settings, thorough verification should be performed on practical sets.

[Setting example]

To set DC/DC drive frequency "f_{sw}" to 200 kHz, R_{RT} is given by the following equation:

$$R_{RT} = \frac{15000}{f_{sw} [kHz]} = \frac{15000}{200 [kHz]} = 75 \quad [k\Omega]$$

●LSP setting procedure

Making a change to the LSP pin input voltage will allow the threshold for LED short circuit protection to be changed.

The LED short circuit detection voltage is set to 6V (Typ.) with the LSP pin being in the open-circuited state. LSP pin input voltage setting should be made in the range of 0.8V to 3V.

The relation between the LSP pin voltage and the LED short circuit protection detection voltage is given by the following equation.

$$LED_{SHORT} = 5 \times VLSP [V]$$

Since the LSP pin divides 3V within the IC using resistive dividers (see the circuit diagram shown below), connecting an external resistor to the LSP pin will produce resistance combined with the internal IC resistance.

Consequently, to make LSP pin voltage setting using external resistive dividers, it is recommended to connect them having resistance little affected by the internal resistance. (Smaller resistance makes the LSP pin increasingly less likely to be affected by the internal resistance, but this results in more power consumption. Careful attention should be paid to this matter.)

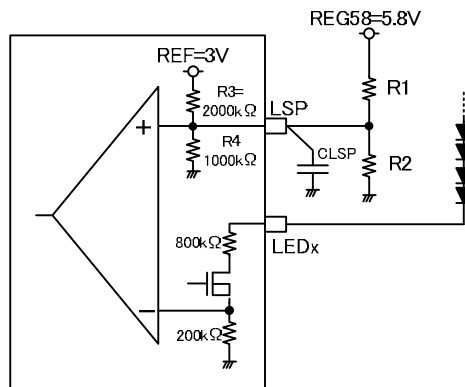

OLSP detection voltage setting equation

If the setting of LSP detection voltage $VLSP$ is made by dividing the REG58 voltage by the use of resistive dividers R1 and R2, $VLSP$ will be given by the following equation:

$$LED_{SHORT} = \left(REG58[V] \times \frac{R2[k\Omega]}{(R1[k\Omega] + R2[k\Omega])} \right) \times 5 [V] \dots (1)$$

However, this equation includes no internal IC resistance. If internal resistance is taken into account, the detection voltage $VLSP$ will be given by the following equation:

$$LED_{SHORT} = \left(\frac{R2[k\Omega] \times R4[k\Omega] \times (REG58[V] \times R3 + REF[V] \times R1[k\Omega])}{(R1[k\Omega] \times R3[k\Omega] \times (R2 + R4) + R2[k\Omega] \times R4[k\Omega] \times (R1[k\Omega] + R3[k\Omega]))} \right) \times 5 [V] \dots (2)$$

Make setting of R1 and R2 resistance so that a difference between resistance values found by Equations (1) and (2) will come to approximately 2% or less as a guide.

[Setting example]

Assuming that LSP is approximated by Equation (1) in order to set LSP detection voltage to 6V, R1 comes to 38.3kΩ and R2 comes to 10kΩ.

When calculating LSP detection voltage taking into account internal IC resistance by Equation (2), it will be given as:

$$VLSP = \left(\frac{10[k\Omega] \times 1000[k\Omega] \times (5.8[V] \times 2000[k\Omega] + 3[V] \times 38.3[k\Omega])}{(38.3[k\Omega] \times 2000[k\Omega] \times (10[k\Omega] + 1000[k\Omega]) + 10[k\Omega] \times 1000[k\Omega] \times (38.3[k\Omega] + 2000[k\Omega]))} \right) \times 5 = 5.992[V]$$

The difference is given as:

$$(5.992[V] - 6[V]) / 6[V] \times 100 = -0.13\%$$

As a result, this setting will be little affected by internal impedance.

● **OVP/SCP Settings**

OVP pin is DC/DC output voltage's over voltage protection and short circuit protection input pin. OVP pin is a high impedance pin with no pull down resistor. Thus, at OPEN state please set the voltage input settings using voltage dividing resistor and such. Respective OVP pin protection conditions are as below

Protection Name	Detection Pin	Detection Condition	Cancellation Condition	Timer Operations	Protection Type
OVP	OVP	OVP>3.0V	OVP<2.9V	No	DCDC stops during detection
SCP	OVP	OVP<0.1V	OVP>0.1V	Yes	All latch

○ **OVP Detection Setting**

VOUT abnormally increase, voltage detected by OVP, VOVP_{DET}, R1,R2 settings are as follows

$$R1 = R2[k\Omega] \times \frac{(VOVP_{DET}[V] - 3.0[V])}{3.0[V]} \quad [k\Omega]$$

○ **OVP Cancellation Setting**

R1,R2 set from above equation, OVP cancellation voltage VOVP_{CAN} equals to

$$VOVP_{CAN} = 2.9V \times \frac{(R1[k\Omega] + R2[k\Omega])}{R2[k\Omega]} \quad [V]$$

○ **SCP Detection Setting**

When R1,R2 are set using values obtained above, SCP voltage setting is VSCP_{DET} is as follows

$$VSCP_{DET} = 0.1V \times \frac{(R1[k\Omega] + R2[k\Omega])}{R2[k\Omega]} \quad [V]$$

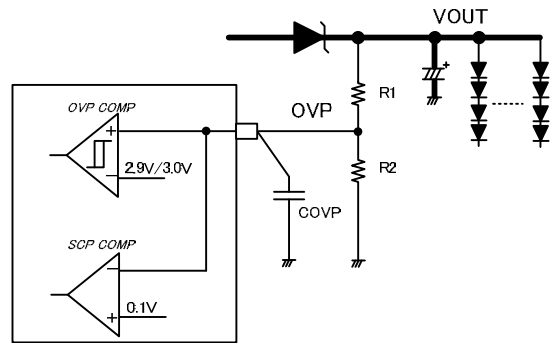

[Setting Example]

VOUT at normal operation 56V, OVP detection voltage VOVP_{DET}=68V, R2=10k, R1 is as follows

$$R1 = R2[k\Omega] \times \frac{(VOVP_{DET}[V] - 3.0[V])}{3.0[V]} = 10[k\Omega] \times \frac{(68[V] - 3[V])}{3[V]} = 216.7 \quad [k\Omega]$$

When R1, R2 are set at these values, OVP cancellation voltage, VOVP_{CAN}

$$VOVP_{CAN} = 2.9[V] \times \frac{(R1[k\Omega] + R2[k\Omega])}{R2[k\Omega]} = 2.9[V] \times \frac{10[k\Omega] + 216.7[k\Omega]}{10[k\Omega]} [V] = 65.7 \quad [V]$$

In addition, at this R1, R2, SCP detection voltage

$$VSCP_{DET} = 0.1[V] \times \frac{(R1[k\Omega] + R2[k\Omega])}{R2[k\Omega]} = 0.1[V] \times \frac{10[k\Omega] + 216.7[k\Omega]}{10[k\Omega]} [V] = 2.27 \quad [V]$$

To select DC/DC components, give consideration to IC variations as well as individual component variations, and then conduct thorough verification on practical systems.

● **Timer Latch Time Setting**

This IC has a built-in timer latch counter. Timer latch time is set by counting the clock frequency which is set at the RT pin.

● **Timer Latch Time**

When various abnormal conditions happen, counting starts from the timing, latch occurs after below time has passed. Furthermore, even if PWM=L, if abnormal condition continues, timer count will not reset.

$$LATCH_{TIME} = 2^{12} \times \frac{R_{RT}}{1.5 \times 10^{10}} = 4096 \times \frac{R_{RT} [k\Omega]}{1.5 \times 10^7} [s]$$

Here, $LATCH_{TIME}$ = time until latch condition occurs
 R_{RT} = Resistor value connected to RT pin

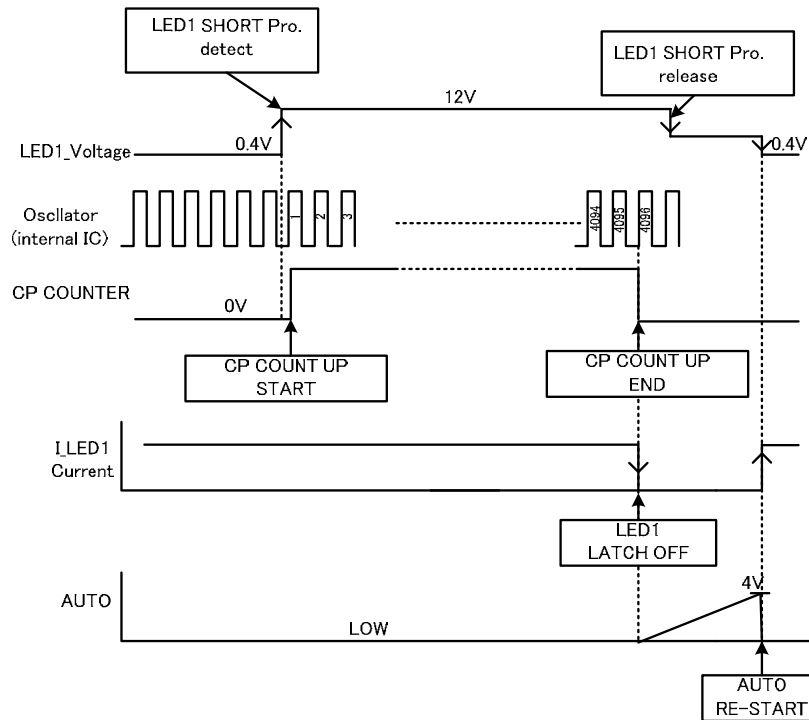

【Setting Example】

Example of LED Short protection timing chart

Timer latch time when $R_T=75k\Omega$

$$LATCH_{TIME} = 4096 \times \frac{R_{RT} [k\Omega]}{1.5 \times 10^7} = 4096 \times \frac{75 [k\Omega]}{1.5 \times 10^7} = 0.02 [s]$$

● - OCP Settings/DCDC Components' Current Capacity Selection Method

One of the function of CS pin - when its pin voltage > 0.45 it stops the DCDC. Thus, RCS resistor value need to be checked after the peak current flow through the inductor is calculated. Furthermore, DCDC external components' current capacity needs to be greater than peak current flowing through this inductor.

(Inductor peak current Ipeak calculation method)

Firstly, ripple voltage which occurs at the CS pin is decided depending on the DCDC application conditions.

The conditions when made as below;

Output voltage = VOUT [V]

LED total current = IOUT [A]

DCDC input voltage = VIN [V]

DCDC efficiency = η [%]

Total required average input current IIN:

$$I_{IN} = \frac{V_{OUT}[V] \times I_{OUT}[A]}{V_{IN}[V] \times \eta[\%]} \quad [A]$$

Inductor ripple current ΔIL [A], which occurs at inductor L [H] during DCDC drive operation with switching frequency = fsw [Hz] is as follows

$$\Delta IL = \frac{(V_{OUT}[V] - V_{IN}[V]) \times V_{IN}[V]}{L[H] \times f_{sw}[Hz]} \quad [A]$$

Therefore, IL's peak current Ipeak can be calculated using below equation

$$I_{peak} = I_{IN}[A] + \frac{\Delta IL[A]}{2} \quad [A] \dots (1)$$

(Resistor RCS connected to CS pin selection method)

This Ipeak flows in RCS and generates voltage. (refer to time chart diagram on the right). This voltage value, VCSpeak can be calculated as below

$$V_{CS\ peak} = R_{cs} \times I_{peak} \quad [V]$$

This VCSpeak when reach 0.45V, will stop the DCDC output. Thus when selecting RCS value, below condition needs to be met.

$$R_{cs}[\Omega] \times I_{peak}[A] < 0.45[V]$$

(DCDC Components' Current Capacity Selection Method)

When OCP reach detection voltage CS=0.45V, Iocp current

$$I_{ocp} = \frac{0.45[V]}{R_{cs}[\Omega]} \quad [A] \dots (2)$$

Ipeak current (1), Iocp current (2), and components' MAX current capacity needs to satisfy the following

$$I_{peak} < I_{ocp} < \text{Rated current of components}$$

Above condition needs to be satisfied when selecting DCDC application parts eg. FET, inductor, diode etc. Furthermore, continuous mode is recommended for normal DCDC applications. Inductor's ripple current MIN limit value, Imin becoming

$$I_{min} = I_{IN}[A] - \frac{\Delta IL[A]}{2} > 0$$

Is a condition to be met. If this is not met, it is called discontinuous mode.

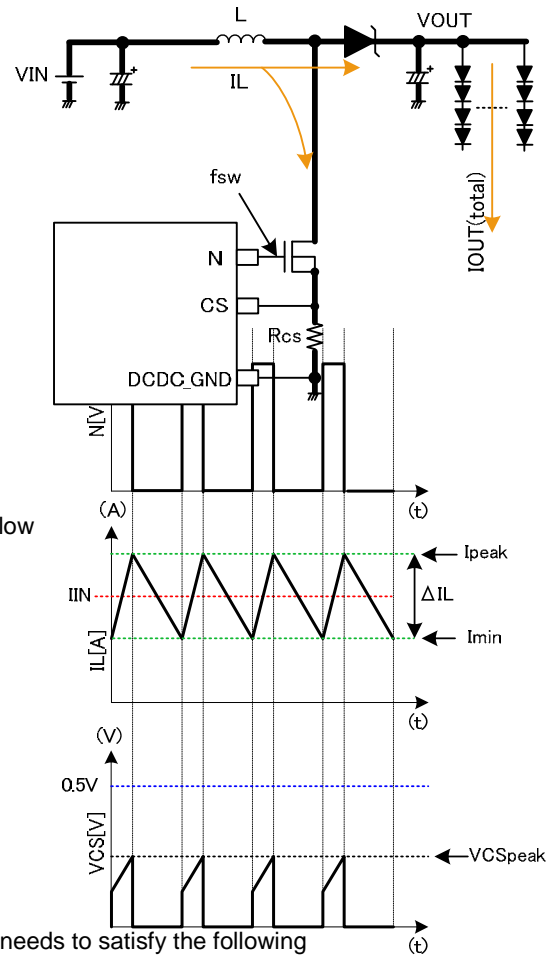

【Setting Example】Output voltage= $V_{OUT}[V]=56V$ LED total current= $I_{OUT}[A]=100mA \times 4ch=0.40A$ DCDC input voltage= $V_{IN}[V]=14V$ DCDC efficiency= $\eta[\%]=90\%$ Total required average input current I_{IN} :

$$I_{IN}[A] = \frac{V_{OUT}[V] \times I_{OUT}[A]}{V_{IN}[V] \times \eta[\%]} = \frac{56[V] \times 0.40[A]}{14[V] \times 90[\%]} = 1.78 [A]$$

When, DCDC switching frequency = $f_{sw}[Hz]=200kHz$ Inductor $L[H]=33\mu H$,Inductor ripple current $\Delta IL[A]$:

$$\Delta IL = \frac{(V_{OUT}[V] - V_{IN}[V]) \times V_{IN}[V]}{L[H] \times V_{OUT}[V] \times f_{sw}[Hz]} = \frac{(56[V] - 14[V]) \times 14[V]}{33 \times 10^{-6}[H] \times 56[V] \times 200 \times 10^3[Hz]} = 1.59 [A]$$

Thus, I_L peak current I_{peak} becomes

$$I_{peak} = I_{IN}[A] + \frac{\Delta IL[A]}{2} [A] = 1.78[A] + \frac{1.59[A]}{2} = 2.58 [A] \quad \dots \text{Peak current calculation result}$$

RCS resistor value when set at 0.1ohm

$$V_{CS_{peak}} = R_{CS} \times I_{peak} = 0.10[\Omega] \times 2.58[A] = 0.258 [V] < 0.45V \quad \dots \text{RCS resistor consideration}$$

and satisfy the condition.

In addition, OCP detection current I_{OCP} at this time is

$$I_{OCP} = \frac{0.45[V]}{0.1[\Omega]} = 4.5 [A]$$

If parts used (FET, INDUCTOR, DIODE etc)'s current capacity < 5A,

$$I_{peak} < I_{OCP} < \text{Rated current of components} = 2.58[A] < 4.5[A] < 5[A]$$

Thus, there is no problem of parts selection as the above condition is satisfied.

...DCDC current capacity considerationIn addition, I_L ripple current minimum limit I_{min} is

$$I_{min} = I_{IN}[A] - \frac{\Delta IL[A]}{2} [A] = 1.78[A] - 0.795[A] = 0.985[A] > 0$$

Thus, will not become discontinuous mode.

To select DC/DC components, give consideration to IC variations as well as individual component variations, and then conduct thorough verification on practical systems.

● Selection of inductor L

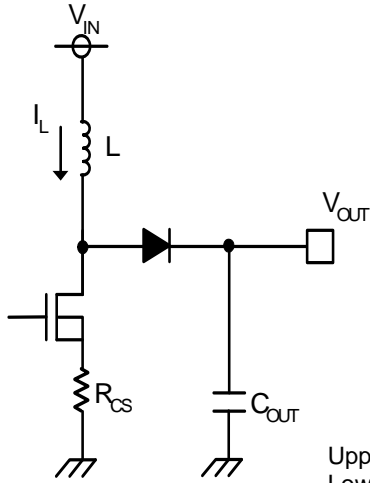
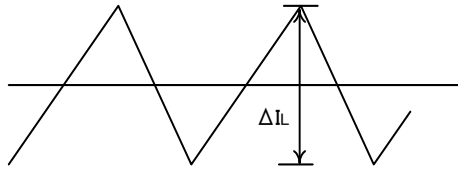

Upper: Fig.15 Inductor current waveform
Lower: Fig.16 DC/DC Converter application Circuit (b)

The value of inductor has significant influence on the input ripple current. As shown by Equation (1), the larger the inductor and the higher the switching frequency, the inductor ripple current ΔIL becomes increasingly lower.

$$\Delta IL = \frac{(V_{OUT} - V_{IN}) \times V_{IN}}{L \times V_{OUT} \times f_{SW}} [A] \quad \dots \dots (1)$$

Expressing efficiency as shown by Equation (2), peak input current is given as Equation (3).

$$\eta = \frac{V_{OUT} \times I_{OUT}}{V_{IN} \times I_{IN}} \quad \dots \dots (2)$$

$$I_{LMAX} = I_{IN} + \frac{\Delta IL}{2} = \frac{V_{OUT} \times I_{OUT}}{V_{IN} \times \eta} + \frac{\Delta IL}{2} \quad \dots \dots (3)$$

where, L: Reactance value [H],
 V_{OUT} : DC/DC output voltage [V],
 V_{IN} : Input voltage [V],
 I_{OUT} : Output load current (total output current) [A],
 I_{IN} : Input current [A], and
 f_{SW} : Oscillation frequency [Hz]

Note: If a current in excess of the rated current of the inductor applies to the coil, the inductor will cause magnetic saturation, resulting in efficiency degradation.

Select an inductor with an adequate margin so that peak current will not exceed the rated current of the inductor.

Note: To reduce power dissipation from and increase efficiency of inductor, select an inductor with low resistance component (DCR or ACR).

● Selection of output capacitor COUT

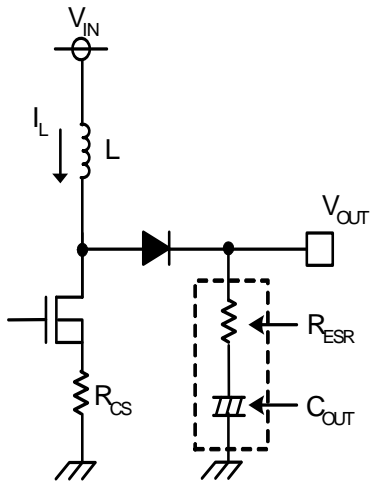

Fig.17 DC/DC converter application circuit (c)

Select a capacitor on the output side taking into account the stability region of output voltage and equivalent series resistance necessary to smooth ripple voltage. Note that higher output ripple voltage may result in a drop in LED pin voltage, making it impossible to supply set LED current.

The output ripple voltage ΔV_{OUT} is given by Equation (4).

$$\Delta V_{OUT} = I_{LMAX} \times R_{ESR} + \frac{1}{C_{OUT}} \times \frac{I_{OUT}}{\eta} \times \frac{1}{f_{SW}} [V] \quad \dots \dots (4)$$

where R_{ESR} = Equivalent series resistance of C_{OUT} .

Note: Select capacitor ratings with an adequate margin for output voltage.

Note: To use an electrolytic capacitor, an adequate margin should be provided for permissible current. Particularly to apply PWM light modulation to LED, note that a current higher than the set LED current transiently flows.

● Selection of switching MOSFET transistors

There will be no problem for switching MOSFET transistors having absolute maximum rating higher than rated current of the inductor L and VF higher than “ C_{OUT} breakdown voltage + Rectifier diode”. However, to achieve high-speed switching, select transistors with small gate capacity (injected charge amount).

Note: Rated current larger than overcurrent protection setting current is recommended.

Note: Selecting transistors with low on resistance can obtain high efficiency.

● Selection of rectifier diodes

Select Schottky barrier diodes having current capability higher than the rated current of the inductor L and inverse breakdown voltage higher than C_{OUT} breakdown voltage, particularly having low forward voltage VF.

●Phase Compensation Setting Procedure

DC/DC converter application for current mode control includes one each of pole f_p (phase delay) by CR filter consisting of output capacitor and output resistor (i.e., LED current) and zero (phase lead) f_z by the output capacitor and capacitor ESR. Furthermore, the step-up DC/DC converter includes RHP zero “ f_{ZRHP} ” as the second zero. Since the RHP zero has phase delay (-90°) characteristics like the pole, the crossover frequency f_c should be set to not more than RHP zero

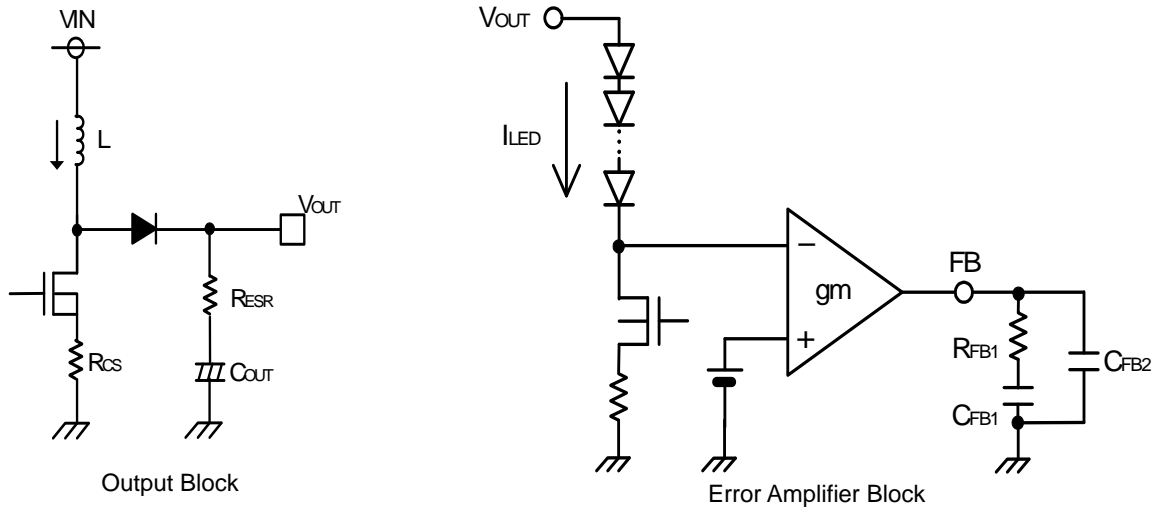

- i. Find pole f_p and RHP zero f_{ZRHP} of DC/DC converter.

$$f_p = \frac{I_{LED}}{2\pi \times V_{OUT} \times C_{OUT}} [Hz] \qquad f_{ZRHP} = \frac{V_{OUT} \times (1-D)^2}{2\pi \times L \times I_{LED}} [Hz]$$

Where I_{LED} = Total LED current [A], $D = \frac{V_{OUT} - V_{IN}}{V_{OUT}}$

- ii. Find phase compensation to be inserted in the error amplifier. (Set f_c to 1/5 of f_{ZRHP} .)

$$R_{FB1} = \frac{f_{RHZP} \times R_{CS} \times I_{LED}}{5 \times f_p \times gm \times V_{OUT} \times (1-D)} [\Omega] \qquad C_{FB1} = \frac{1}{2\pi \times R_{FB1} \times f_p} [F]$$

where $gm = 4.0 \times 10^{-4} [S]$

- iii. Find zero used to compensate ESR (R_{ESR}) of C_{OUT} (electrolytic capacitor).

$$C_{FB2} = \frac{R_{ESR} \times C_{OUT}}{R_{FB1}} [F]$$

Note: Even if a ceramic capacitor (R_{ESR} of the order of milliohms) for C_{OUT} , it is recommended to insert C_{FB2} for stable operation.

To improve transient response, it is necessary to increase R_{FB1} and reduce C_{FB1} . However, this improvement reduces a phase margin. To avoid this problem, conduct thorough verification, including variations in external components, on practical systems.

●Timing Chart

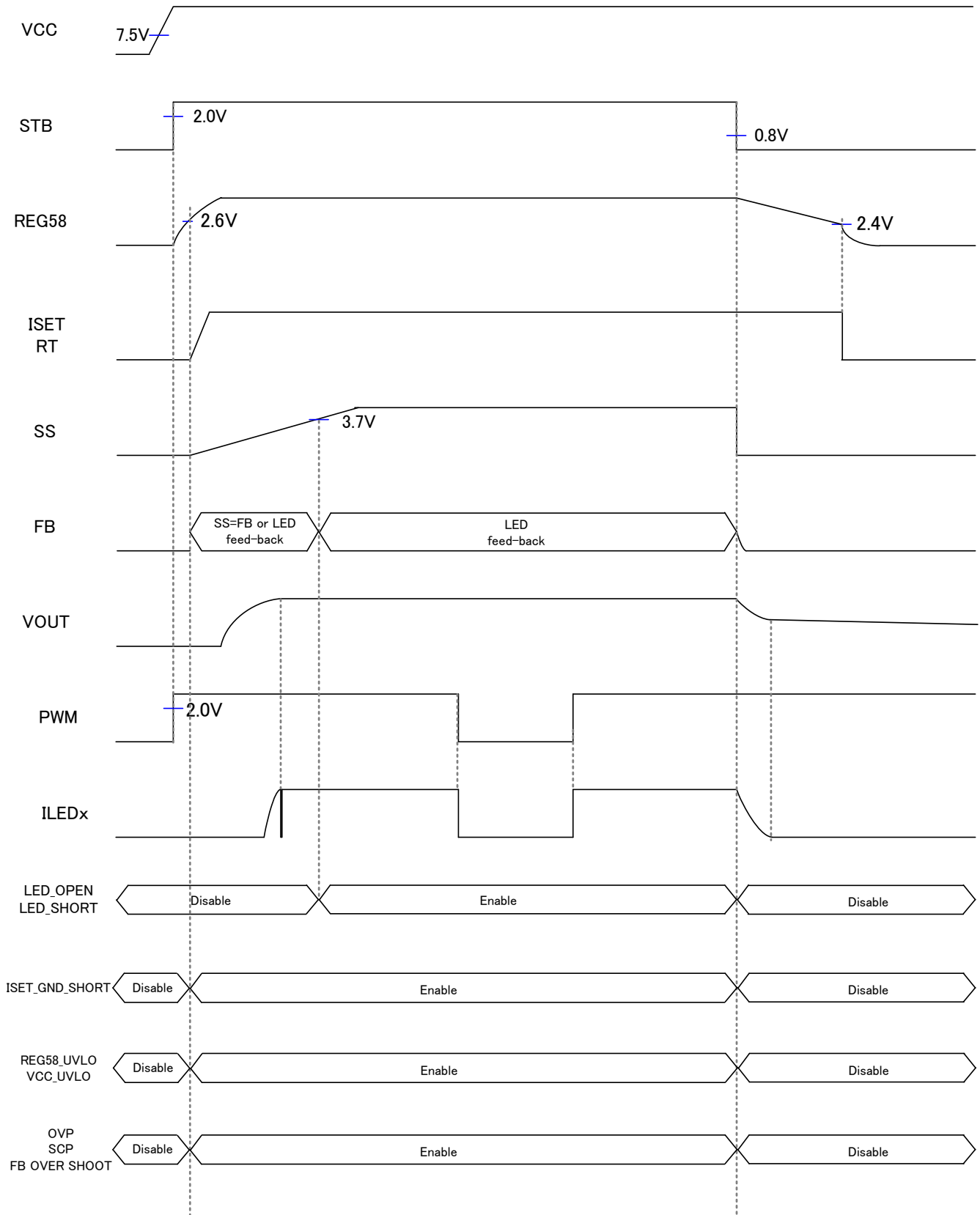

●List of Protect Function (typ condition)

Protection Name	Detection Pin	Detection Conditions			Cancellation Conditions	Protection Type
		Detection pin	PWM	SS		
LED OPEN	LEDx	LEDx < 0.2V	H	SS>3.7V	LEDx > 0.2V	Immediately Auto-Restart after detection (Judge periodically whether normal or not)
LEDSHORT	LEDx	LEDx > 5V (LSP=OPEN)	H	SS>3.7V	LEDx < 5V (LSP=OPEN)	Immediately Auto-Restart after detection (Judge periodically whether normal or not)
ISET GND SHORT	ISET	Under ISET×90%	-	-	Above ISET×90%	Auto-Restart
REG58 UVLO	REG58	REG58<2.4V	-	-	REG58>2.6V	Auto-Restart
VCC UVLO	VCC	VCC<7.3V	-	-	VCC>7.5V	Auto-Restart
OVP	OVP	OVP>3.0V	-	-	OVP<2.9V	Auto-Restart
SCP	OVP	OVP<0.1V	-	-	OVP>0.1V	Immediately Auto-Restart after detection (Judge periodically whether normal or not)
FB OVER SHOOT	FB	FB>4V	-	-	FB<3.6V	Immediately Auto-Restart after detection (Judge periodically whether normal or not)
OCP	CS	OCP>0.45V	-	-	-	Pulse-by-Pulse

To clear the latch type, STB should be set to "L" once, and then to "H".

Protection Function	Operation after the protection function detected		
	DC/DC	LED Driver	Soft-start
LED OPEN	Continue to operate	Only detects LED, stops after CP count	Continue to operate
LEDSHORT	Continue to operate	Only detects LED, stops after CP count	Continue to operate
ISET GND SHORT	Stop immediately	Stop immediately	Continue to operate
STB	Stop immediately	Stop(and when REG58<2.4V)	Discharge immediately
REG58 UVLO	Stop immediately	Stop immediately	Discharge immediately
VCC UVLO	Stop immediately	Stop immediately	Discharge immediately
OVP	Stop immediately (N pin only)	Continue to operate	Continue to operate
SCP	Stop immediately (N pin only)	Stop after CP count	Discharge after CP count
FB OVER SHOOT	Stop after CP count	Stop after CP count	Continue to operate
OCP	N pin limits DUTY	Stop immediately	Continue to operate

* CP = 20msec (RT=75Kohm)

●Operational Notes

- 1) We pay utmost attention to the quality control of this product. However, if it exceeds the absolute maximum ratings including applied voltage and operating temperature range, it may lead to its deterioration or breakdown. Further, this makes it impossible to assume a breakdown state such as short or open circuit mode. If any special mode to exceed the absolute maximum ratings is assumed, consider adding physical safety measures such as fuses.
- 2) Making a reverse connection of the power supply connector can cause the IC to break down. To protect the IC from breakdown due to reverse connection, take preventive measures such as inserting a diode between the external power supply and the power supply pin of the IC.
- 3) Since current regenerated by back electromotive force flows back, take preventive measures such as inserting a capacitor between the power supply and the ground as a path of the regenerative current and fully ensure that capacitance presents no problems with characteristics such as lack of capacitance of electrolytic capacitors causes at low temperatures, and then determine the power supply line. Provide thermal design having an adequate margin in consideration of power dissipation (Pd) in the practical operating conditions.
- 4) The potential of the GND pin should be maintained at the minimum level in any operating state.
- 5) Provide thermal design having an adequate margin in consideration of power dissipation (Pd) in the practical operating conditions.
- 6) To mount the IC on a printed circuit board, pay utmost attention to the direction and displacement of the IC. Furthermore, the IC may get damaged if it is mounted in an erroneous manner or if a short circuit is established due to foreign matters entered between output pins or between output pin and power supply GND pin.
- 7) Note that using this IC in strong magnetic field may cause it to malfunction.
- 8) This IC has a built-in thermal-protection circuit (TSD circuit), which is designed to be activated if the IC junction temperature reached 150°C to 200°C and deactivated with hysteresis of 10°C or more. The thermal-protection circuit (TSD circuit) is a circuit absolutely intended to protect the IC from thermal runaway, not intended to protect or guarantee the IC. Consequently, do not use the IC based on the activation of this TSD circuit for subsequent continuous use and operation of the IC.
- 9) When testing the IC on a set board with a capacitor connected to the pin, the IC can be subjected to stress. In this case, be sure to discharge the capacitor for each process. In addition, to connect the IC to a jig up to the testing process, be sure to turn OFF the power supply prior to connection, and disconnect the jig only after turning OFF the power supply.
- 10) This monolithic IC contains P + Isolation and P substrate layers between adjacent elements in order to keep them isolated. P-N junctions are formed at the intersections of these P layers and the N layers of other elements, thus making up different types of parasitic elements.

For example, if a resistor and a transistor is connected with pins respectively as shown in Fig.

○When $GND > (Pin A)$ for the resistor, or when $GND > (Pin B)$ for the transistor (NPN), P-N junctions operate as a parasitic diode.

○When $GND > (Pin B)$ for the transistor (NPN), the parasitic NPN transistor operates by the N layer of other element adjacent to the parasitic diode aforementioned.

Due to the structure of the IC, parasitic elements are inevitably formed depending on the relationships of potential. The operation of parasitic diodes can result in interferences in circuit operation, leading to malfunctions and eventually breakdown of the IC. Consequently, pay utmost attention not to use the IC for any applications by which the parasitic elements are operated, such as applying a voltage lower than that of GND (P substrate) to the input pin.

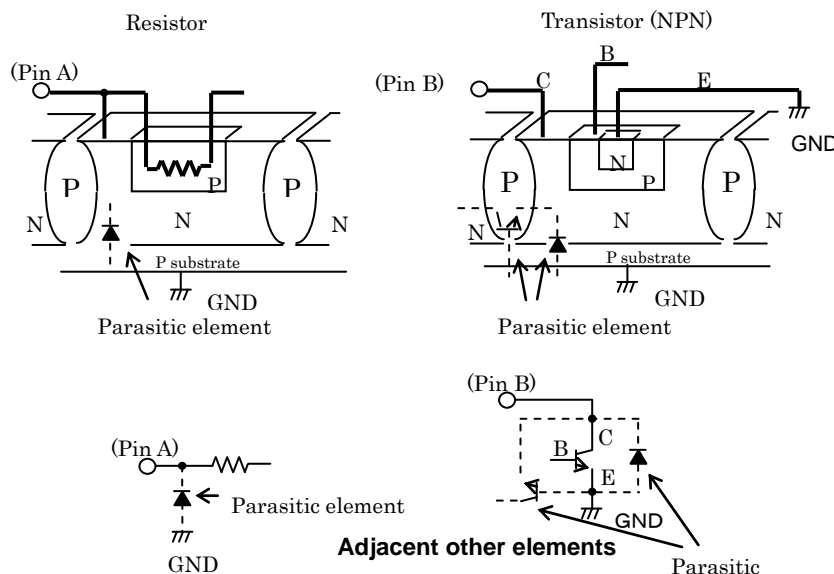

Fig18. Example of Simple Structure of Monolithic IC

Status of this document

The Japanese version of this document is formal specification. A customer may use this translation version only for a reference to help reading the formal version.

If there are any differences in translation version of this document formal version takes priority

●Ordering Information

B D 9 3 9 4 F P

-

E 2

Part Number

Package
FP: HSOP20
EFV: HTSSOP-B24

Packaging and forming specification
E2: Embossed tape and reel

●Physical Dimension Tape and Reel Information (HSOP20)

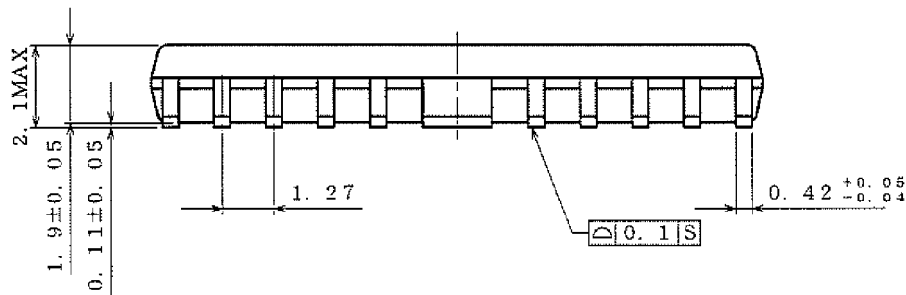
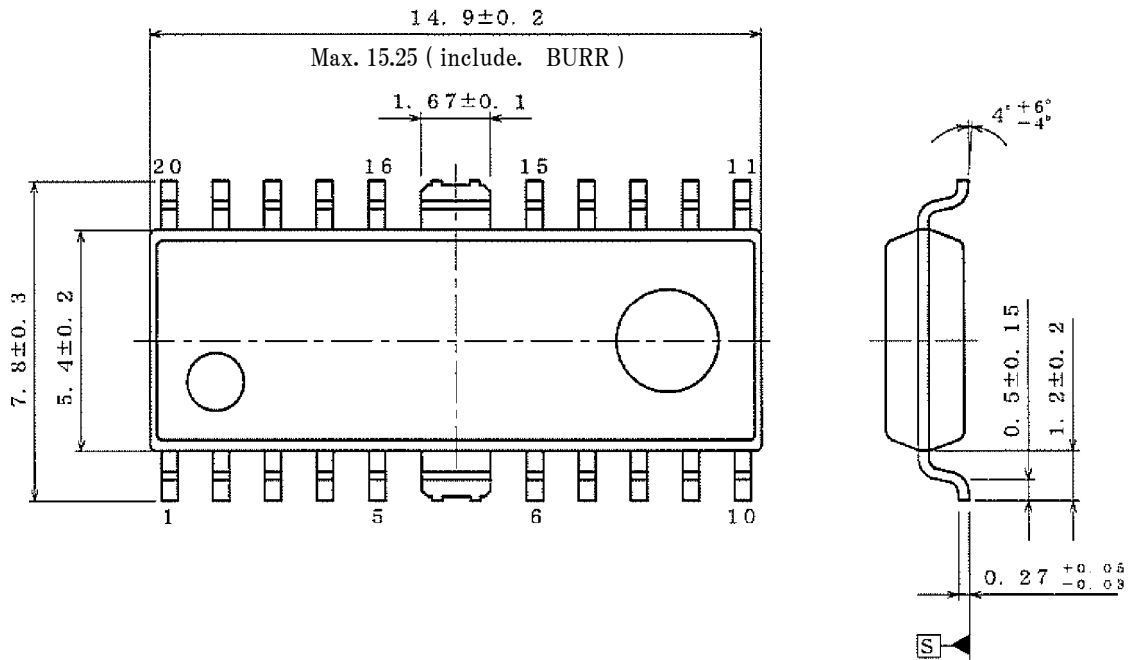

(UNIT : mm)

Drawing No. : EX 2 1 1 - 6 0 0 1

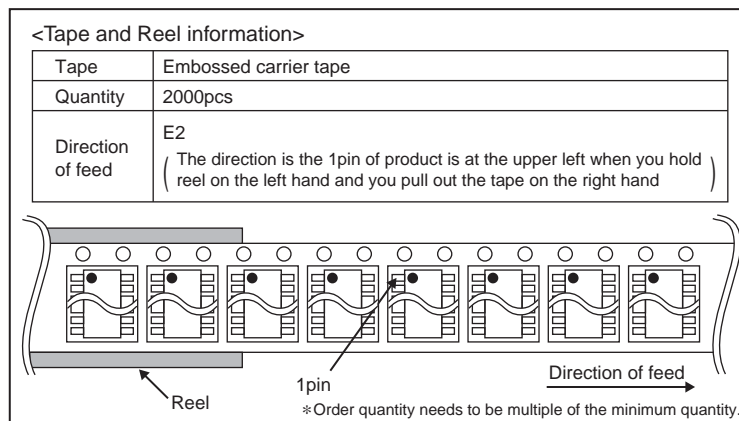

●Physical Dimension Tape and Reel Information (HTSSOP-B24)

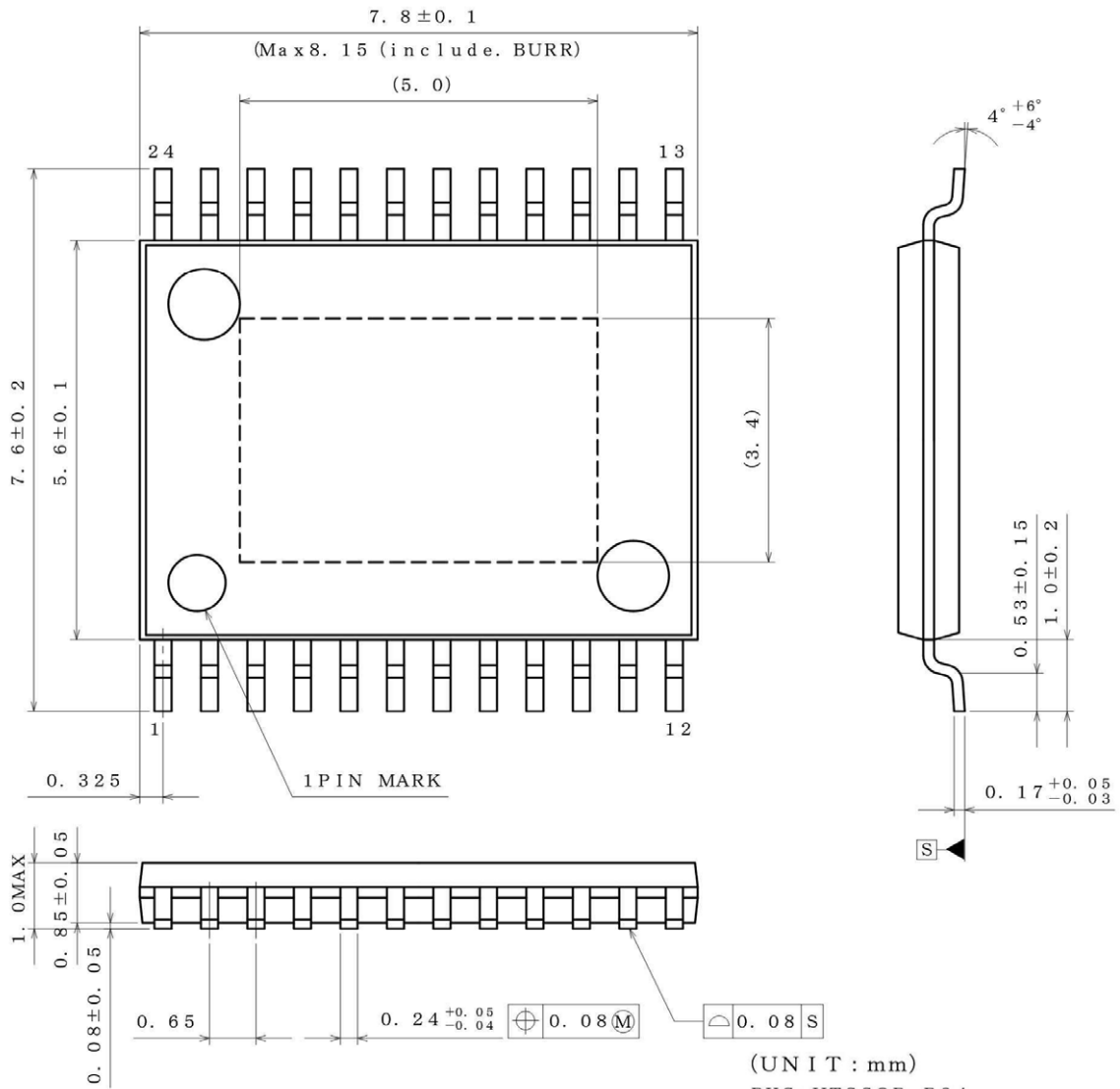

(UNIT : mm)
PKG : HTSSOP-B24
Drawing No. EX191-5002-1

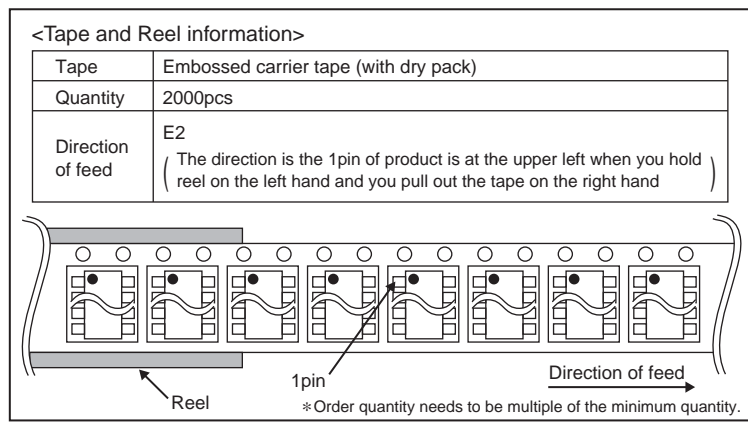

●Revision History

Date	Revision	Changes
12.Oct.2012	001	New Release
09.Nov.2012	002	Page. 10: Add ISET pin function
09.May.2014	003	Page. 1, 9: Revise pin name (AGND→GND)

Notice

Precaution on using ROHM Products

- Our Products are designed and manufactured for application in ordinary electronic equipments (such as AV equipment, OA equipment, telecommunication equipment, home electronic appliances, amusement equipment, etc.). If you intend to use our Products in devices requiring extremely high reliability (such as medical equipment ^(Note 1), transport equipment, traffic equipment, aircraft/spacecraft, nuclear power controllers, fuel controllers, car equipment including car accessories, safety devices, etc.) and whose malfunction or failure may cause loss of human life, bodily injury or serious damage to property ("Specific Applications"), please consult with the ROHM sales representative in advance. Unless otherwise agreed in writing by ROHM in advance, ROHM shall not be in any way responsible or liable for any damages, expenses or losses incurred by you or third parties arising from the use of any ROHM's Products for Specific Applications.

(Note1) Medical Equipment Classification of the Specific Applications

JAPAN	USA	EU	CHINA
CLASS III	CLASS III	CLASS II b	CLASS III
CLASS IV		CLASS III	

- ROHM designs and manufactures its Products subject to strict quality control system. However, semiconductor products can fail or malfunction at a certain rate. Please be sure to implement, at your own responsibilities, adequate safety measures including but not limited to fail-safe design against the physical injury, damage to any property, which a failure or malfunction of our Products may cause. The following are examples of safety measures:
 - Installation of protection circuits or other protective devices to improve system safety
 - Installation of redundant circuits to reduce the impact of single or multiple circuit failure
- Our Products are designed and manufactured for use under standard conditions and not under any special or extraordinary environments or conditions, as exemplified below. Accordingly, ROHM shall not be in any way responsible or liable for any damages, expenses or losses arising from the use of any ROHM's Products under any special or extraordinary environments or conditions. If you intend to use our Products under any special or extraordinary environments or conditions (as exemplified below), your independent verification and confirmation of product performance, reliability, etc. prior to use, must be necessary:
 - Use of our Products in any types of liquid, including water, oils, chemicals, and organic solvents
 - Use of our Products outdoors or in places where the Products are exposed to direct sunlight or dust
 - Use of our Products in places where the Products are exposed to sea wind or corrosive gases, including Cl₂, H₂S, NH₃, SO₂, and NO₂
 - Use of our Products in places where the Products are exposed to static electricity or electromagnetic waves
 - Use of our Products in proximity to heat-producing components, plastic cords, or other flammable items
 - Sealing or coating our Products with resin or other coating materials
 - Use of our Products without cleaning residue of flux (even if you use no-clean type fluxes, cleaning residue of flux is recommended); or Washing our Products by using water or water-soluble cleaning agents for cleaning residue after soldering
 - Use of the Products in places subject to dew condensation
- The Products are not subject to radiation-proof design.
- Please verify and confirm characteristics of the final or mounted products in using the Products.
- In particular, if a transient load (a large amount of load applied in a short period of time, such as pulse. is applied, confirmation of performance characteristics after on-board mounting is strongly recommended. Avoid applying power exceeding normal rated power; exceeding the power rating under steady-state loading condition may negatively affect product performance and reliability.
- De-rate Power Dissipation (Pd) depending on Ambient temperature (Ta). When used in sealed area, confirm the actual ambient temperature.
- Confirm that operation temperature is within the specified range described in the product specification.
- ROHM shall not be in any way responsible or liable for failure induced under deviant condition from what is defined in this document.

Precaution for Mounting / Circuit board design

- When a highly active halogenous (chlorine, bromine, etc.) flux is used, the residue of flux may negatively affect product performance and reliability.
- In principle, the reflow soldering method must be used; if flow soldering method is preferred, please consult with the ROHM representative in advance.

For details, please refer to ROHM Mounting specification

Precautions Regarding Application Examples and External Circuits

1. If change is made to the constant of an external circuit, please allow a sufficient margin considering variations of the characteristics of the Products and external components, including transient characteristics, as well as static characteristics.
2. You agree that application notes, reference designs, and associated data and information contained in this document are presented only as guidance for Products use. Therefore, in case you use such information, you are solely responsible for it and you must exercise your own independent verification and judgment in the use of such information contained in this document. ROHM shall not be in any way responsible or liable for any damages, expenses or losses incurred by you or third parties arising from the use of such information.

Precaution for Electrostatic

This Product is electrostatic sensitive product, which may be damaged due to electrostatic discharge. Please take proper caution in your manufacturing process and storage so that voltage exceeding the Products maximum rating will not be applied to Products. Please take special care under dry condition (e.g. Grounding of human body / equipment / solder iron, isolation from charged objects, setting of Ionizer, friction prevention and temperature / humidity control).

Precaution for Storage / Transportation

1. Product performance and soldered connections may deteriorate if the Products are stored in the places where:
 - [a] the Products are exposed to sea winds or corrosive gases, including Cl₂, H₂S, NH₃, SO₂, and NO₂
 - [b] the temperature or humidity exceeds those recommended by ROHM
 - [c] the Products are exposed to direct sunshine or condensation
 - [d] the Products are exposed to high Electrostatic
2. Even under ROHM recommended storage condition, solderability of products out of recommended storage time period may be degraded. It is strongly recommended to confirm solderability before using Products of which storage time is exceeding the recommended storage time period.
3. Store / transport cartons in the correct direction, which is indicated on a carton with a symbol. Otherwise bent leads may occur due to excessive stress applied when dropping of a carton.
4. Use Products within the specified time after opening a humidity barrier bag. Baking is required before using Products of which storage time is exceeding the recommended storage time period.

Precaution for Product Label

QR code printed on ROHM Products label is for ROHM's internal use only.

Precaution for Disposition

When disposing Products please dispose them properly using an authorized industry waste company.

Precaution for Foreign Exchange and Foreign Trade act

Since our Products might fall under controlled goods prescribed by the applicable foreign exchange and foreign trade act, please consult with ROHM representative in case of export.

Precaution Regarding Intellectual Property Rights

1. All information and data including but not limited to application example contained in this document is for reference only. ROHM does not warrant that foregoing information or data will not infringe any intellectual property rights or any other rights of any third party regarding such information or data. ROHM shall not be in any way responsible or liable for infringement of any intellectual property rights or other damages arising from use of such information or data.:
2. No license, expressly or implied, is granted hereby under any intellectual property rights or other rights of ROHM or any third parties with respect to the information contained in this document.

Other Precaution



1. This document may not be reprinted or reproduced, in whole or in part, without prior written consent of ROHM.
2. The Products may not be disassembled, converted, modified, reproduced or otherwise changed without prior written consent of ROHM.
3. In no event shall you use in any way whatsoever the Products and the related technical information contained in the Products or this document for any military purposes, including but not limited to, the development of mass-destruction weapons.
4. The proper names of companies or products described in this document are trademarks or registered trademarks of ROHM, its affiliated companies or third parties.

General Precaution



1. Before you use our Products, you are requested to carefully read this document and fully understand its contents. ROHM shall not be in any way responsible or liable for failure, malfunction or accident arising from the use of any ROHM's Products against warning, caution or note contained in this document.
2. All information contained in this document is current as of the issuing date and subject to change without any prior notice. Before purchasing or using ROHM's Products, please confirm the latest information with a ROHM sales representative.
3. The information contained in this document is provided on an "as is" basis and ROHM does not warrant that all information contained in this document is accurate and/or error-free. ROHM shall not be in any way responsible or liable for any damages, expenses or losses incurred by you or third parties resulting from inaccuracy or errors of or concerning such information.

Looking for pricing, stock, or lifecycle information?

Click below to explore more details on WIN SOURCE:

-  [View BD9394FP-E2 on WIN SOURCE](#)
-  [Rohm Semiconductor](#) Information

Optimize Your Supply Chain with WIN SOURCE Solutions

-  Global Sourcing Solution
-  Obsolete Management
-  Cost Control Management
-  Shortage Management
-  Alternative Solution
-  Excess Inventory Management