



**THE DATASHEET OF
AP3616M28-G1**



SIXTEEN-CHANNEL, 75mA CURRENT SINK WITH CURRENT MATCH AP3616**General Description**

The AP3616 is an sixteen-channel constant current sink with current match used for LED driver. It uses an external resistor to set the current for sixteen LED strings with an accuracy of $\pm 1.5\%$. The full scale LED current can be adjusted from 20mA to 75mA for each channel. The LED lightness can be adjusted by PWM dimming function.

The device can keep working normally without any damage when LEDs are short or open. It features under voltage lockout protection and over temperature protection.

The AP3616 has three interface terminals (FB, SYN and FBX pins). The FB and SYN pins allow the device to work with a DC/DC converter to drive LED arrays for good performance. And the FBX pin enables the device to be connected in parallel.

The AP3616 is available in SOIC-28 and HSOP-28 packages.

Features

- Input Voltage Range: 4.2V to 27V
- Maximum Output Current: Typical 1.2A (75mA per Channel)
- Current Match Accuracy (Typical): $\pm 1.5\%$
- PWM / Linear Dimming Control
- Open LED Self-check and Protection
- Flexible Short LED Protection
- Under Voltage Lockout Protection
- Over Temperature Protection
- FBX and SYN Pins Enable Parallel Application
- Over Voltage Protection

Applications

- LCD Display Modules
- LCD Monitor
- LCD TV

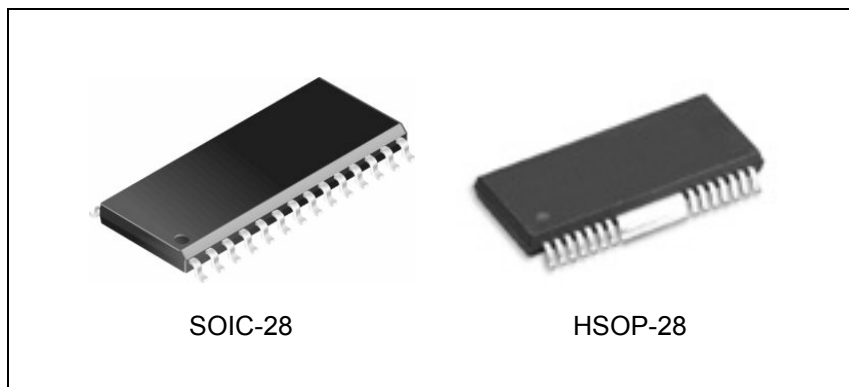

Figure 1. Package Types of AP3616

SIXTEEN-CHANNEL, 75mA CURRENT SINK WITH CURRENT MATCH AP3616

Pin Configuration

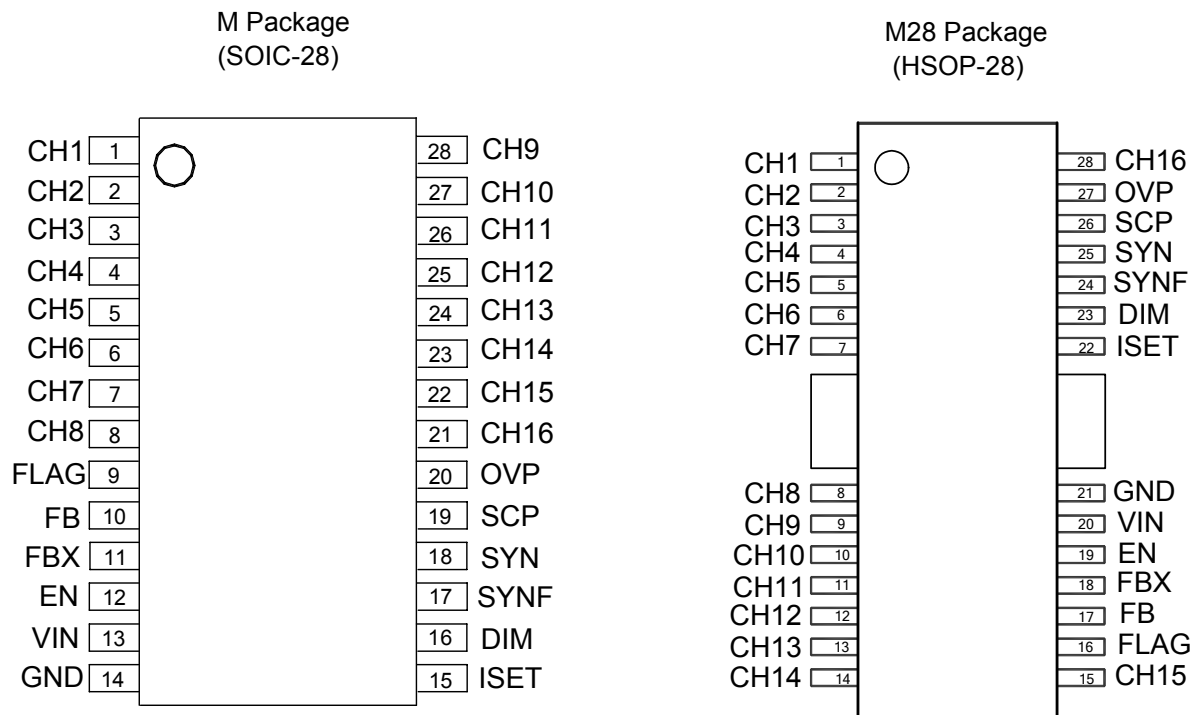

Figure 2. Pin Configuration of AP3616 (Top View)

**SIXTEEN-CHANNEL, 75mA CURRENT SINK WITH CURRENT MATCH AP3616****Pin Description**

Pin Number		Pin Name	Function
SOIC-28	HSOP-28		
1 to 8 28 to 21	1 to 8 9 to 15 & 28	CH1 to CH8 CH9 to CH16	White LED cathode connection pins. If not used, leave them unconnected
9	16	FLAG	Error flag pin. When LED load goes to error (short or open), the flag open drain output will close
10	17	FB	Feedback pin. This pin is an interface terminal, which samples the voltage of each channel, and outputs the lowest voltage of the string to DC/DC converter
11	18	FBX	This pin is an interface terminal. Connect it to FB pin can achieve parallel application. If not used, leave it unconnected
12	19	EN	Enable pin. Logic high enables the IC and logic low disables the IC
13	20	VIN	Input voltage pin
14	21	GND	Ground pin
15	22	ISET	LED current setting pin. An external resistor is connected to this pin. Current on each channel can be expressed by $I_{CHANNEL} = 1.194 * 1560 / R_{ISET}$
16	23	DIM	Dimming control pin. Adding a PWM signal or DC signal to this pin to control LED dimming. Connect it to high voltage level if not used
17	24	SYNF	Synchronous PWM frequency setting pin. A nF level of capacitor should be connected to this pin to set PWM frequency at about 80Hz to 25kHz
18	25	SYN	PWM dimming synchronous pin, this pin outputs DC transformed PWM signal to synchronize parallel AP3616 and power converter, if not used, leave it unconnected
19	26	SCP	LED short trigger voltage setting pin. This pin is used to set the LED short circuit protection voltage level
20	27	OVP	This pin is used to trigger OVP condition. OVP triggering voltage should be lower than the OVP voltage of its cascade chip, such as AP3039A in Figure 19



SIXTEEN-CHANNEL, 75mA CURRENT SINK WITH CURRENT MATCH AP3616

Functional Block Diagram

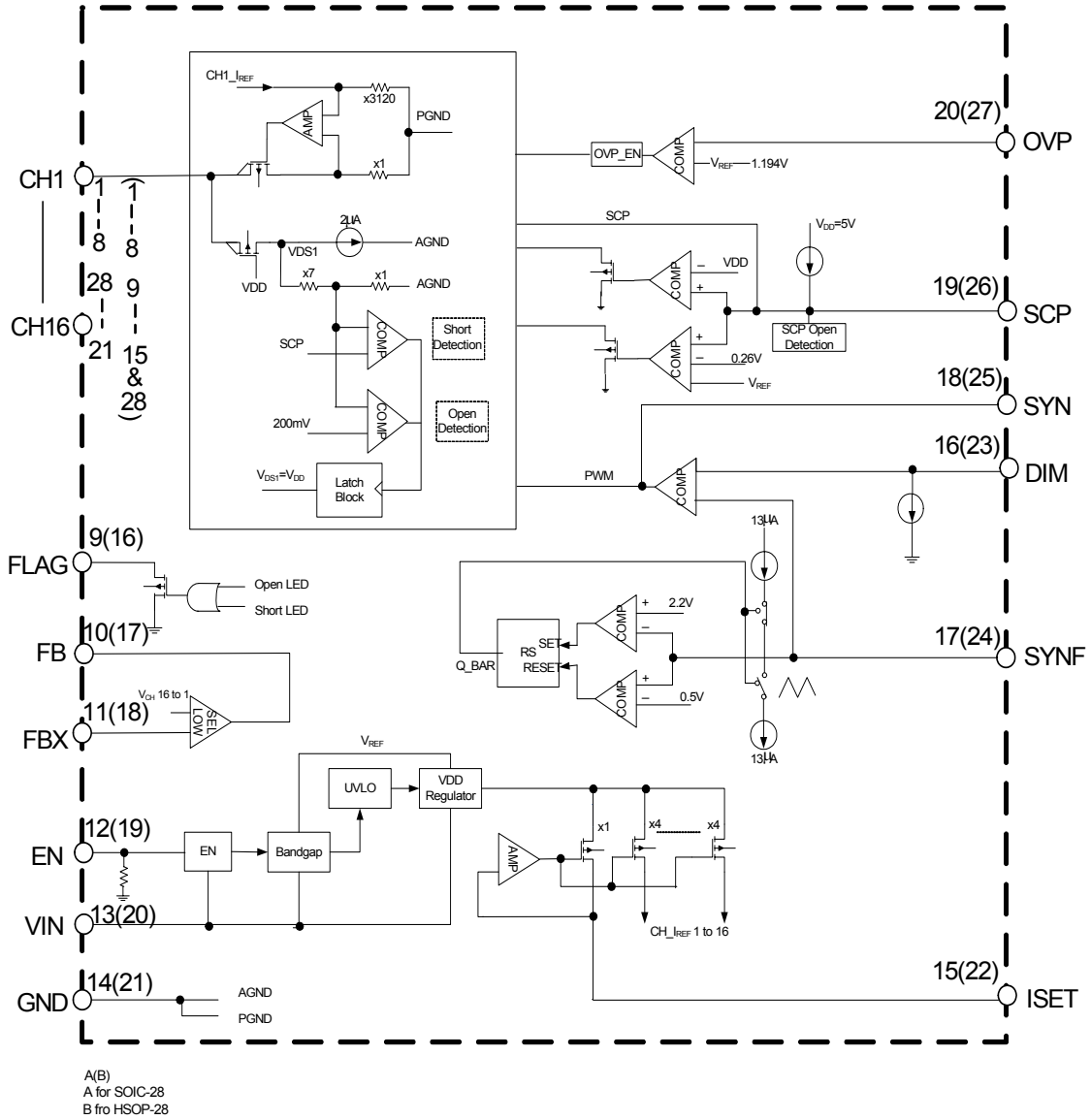
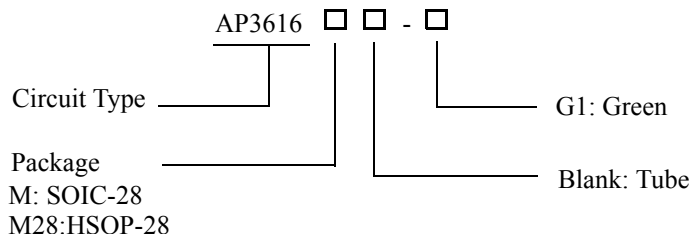

Figure 3. Functional Block Diagram of AP3616



SIXTEEN-CHANNEL, 75mA CURRENT SINK WITH CURRENT MATCH AP3616

Ordering Information



Package	Temperature Range	Part Number	Marking ID	Packing Type
SOIC-28	-40 to 85°C	AP3616M-G1	AP3616M-G1	Tube
HSOP-28		AP3616M28-G1	AP3616M28-G1	Tube

BCD Semiconductor's Pb-free products, as designated with "G1" suffix in the part number, are RoHS compliant and green.

Absolute Maximum Ratings (Note 1)

Parameter	Symbol	Value	Unit
Input Voltage	V_{IN}	30	V
FLAG Pin Voltage	V_{FLAG}	30	V
EN Pin Voltage	V_{EN}	30	V
Voltage on Each Channel	V_{CHX}	-0.3 to 60	V
Voltage on Other Seperate Pins		-0.3 to 6	V
Thermal Resistance (Junction to Ambient, No Heat Sink)	SOIC-28	θ_{JA}	72 °C/W
	HSOP-28		59 °C/W
Operating Junction Temperature	T_J	150	°C
Lead Temperature (Soldering, 10sec)	T_{STG}	-65 to 150	°C
ESD (Human Body Model)		2000	V
ESD (Machine Model)		200	V

Note 1: Stresses greater than those listed under "Absolute Maximum Ratings" may cause permanent damage to the device. These are stress ratings only, and functional operation of the device at these or any other conditions beyond those indicated under "Recommended Operating Conditions" is not implied. Exposure to "Absolute Maximum Ratings" for extended periods may affect device reliability.



SIXTEEN-CHANNEL, 75mA CURRENT SINK WITH CURRENT MATCH AP3616

Recommended Operating Conditions

Parameter	Symbol	Min	Max	Unit	
Input Voltage	V_{CC}	4.2	27	V	
Recommended PWM Dimming Frequency	f_{PWM}	0.08	25	kHz	
Full Scale Setting Current per Channel	$V_{CHX}=0.5V$	I_{CHX}	20	40	mA
	$V_{CHX}=0.8V$		20	60	
	$V_{CHX}=1.2V$		20	75	
Operating Temperature Range	T_A	-40	85	°C	

Electrical Characteristics

$V_{IN}=24V$, $V_{EN}=5V$, $T_A=25^{\circ}C$, unless otherwise specified. **Boldface type** apply over the full operating temperature range ($T_A=-40^{\circ}C$ to $85^{\circ}C$).

Parameter	Symbol	Conditions	Min	Typ	Max	Unit
VCC SECTION						
Quiescent Current	I_Q	ISET, SYN and FB Pin Floating		2	4	mA
Shutdown Supply Current	I_{STBY}	$V_{EN}=0V$, ISET,SYN and FB Pin Floating		0.1	1	μA
Under Voltage Lockout Threshold	V_{UVLO}	VIN Falling Edge	3.65	3.9	4.15	V
Under Voltage Lockout Hysteresis	V_{UVLO_HYS}			300		mV
CHANNEL SECTION						
Maximum Output Current per Channel	I_{CHX_MAX}	$V_{CHX}=0.8V$, $R_{ISET}=0$	75			mA
Current Sink Saturation Voltage per Channel	V_{CHX_SAT}	$I_{CHX}=60mA$			0.6	V
Current Matching Accuracy between Any Two Channels	$I_{CH_MATCHING}$	$I_{CHX}=60mA$, $V_{CH}=0.8V$			3	%
Output Current Load Regulation		$V_{CHX}=0.5V$ to $2.8V$			4	%
Output Current Line Regulation (Note 2)		$V_{CHX}=4.2V$ to $2.8V$			2	%/V

Note 2: Guaranteed by design (GBD).



SIXTEEN-CHANNEL, 75mA CURRENT SINK WITH CURRENT MATCH AP3616

Electrical Characteristics (Continued)

$V_{IN}=24V$, $V_{EN}=5V$, $T_A=25^{\circ}C$, unless otherwise specified. **Boldface type** apply over the full operating temperature range ($T_A=-40^{\circ}C$ to $85^{\circ}C$).

Parameter	Symbol	Conditions	Min	Typ	Max	Unit
DIMMING SECTION						
PWM High Level Threshold Voltage	V_{IH_PWM}		2.5			V
PWM Low Level Threshold Voltage	V_{IL_PWM}				0.3	V
Linear Dimming Level	V_{L_DIM}		0.5		2.2	V
LED SHORT PROTECTION SECTION						
SCP Current	I_{SCP}		10.5	12.5	14.5	μA
CURRENT SINK SECTION						
ISET Reference Voltage	V_{ISET}	$R_{ISET}=30k$, CH1 to CH16 Floating	1.170	1.194	1.218	V
I_{CHX}/I_{SET} Current Multiplication Ratio	k	$R_{ISET}=30k$, $V_{CHX}=1V$		1615		
ENABLE SECTION						
EN Pin High Level Threshold	V_{IH_EN}		2.0			V
EN Pin Low Level Threshold	V_{IL_EN}				0.8	V
OVP SECTION						
Threshold Voltage	$V_{THRESHOLD}$		1.130	1.194	1.250	V
FLAG SECTION						
Saturation Voltage	V_{SAT}	$I_{SINK}=2mA$			0.3	V
SYN SECTION						
PWM Frequency	f_{PWM}		0.08		25	kHz
SYNF High Level Output Voltage	V_{OUT_H}		2.4			V
SYNF Low Level Output Voltage	V_{OUT_L}				0.4	V
FB SECTION						
Feedback Output Current	I_{FB}	V_{FB} Drop to 97%	13	17		μA
TOTAL DEVICE						
Thermal Shutdown Temperature	T_{OTSD}	CHX Pin Left Floating		160		$^{\circ}C$
Thermal Shutdown Hysteresis	T_{HYS}			20		$^{\circ}C$



SIXTEEN-CHANNEL, 75mA CURRENT SINK WITH CURRENT MATCH AP3616

Typical Performance Characteristics

$V_{IN}=24V$, $V_{EN}=5V$, $R_{ISET}=30k\Omega$, $T_A=25^\circ C$, unless otherwise specified.

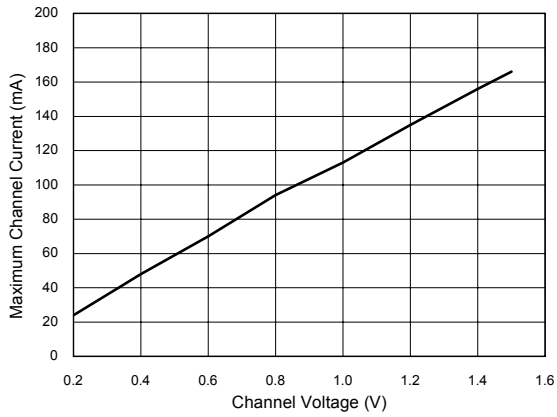

Figure 4. Maximum Channel Current vs. Channel Voltage

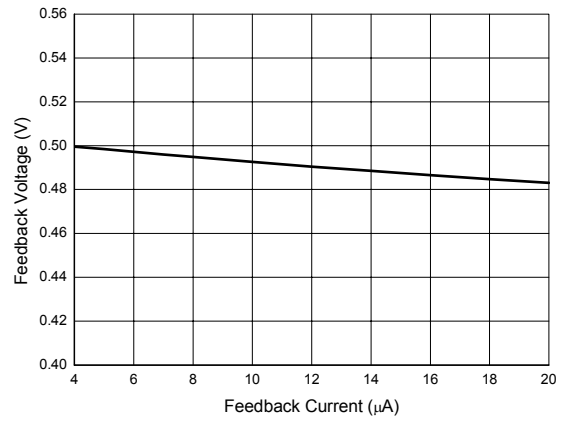

Figure 5. Feedback Voltage vs. Feedback Current

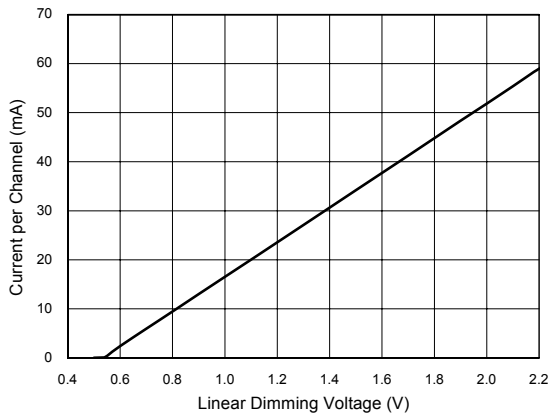

Figure 6. Channel Current vs. Linear Dimming Voltage

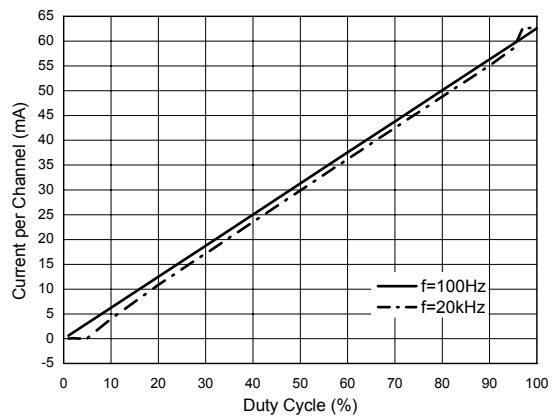

Figure 7. Current per Channel vs. Duty Cycle (PWM Dimming)



SIXTEEN-CHANNEL, 75mA CURRENT SINK WITH CURRENT MATCH AP3616

Typical Performance Characteristics (Continued)

$V_{IN}=24V$, $V_{EN}=5V$, $R_{ISET}=30k\Omega$, $T_A=25^\circ C$, unless otherwise specified.

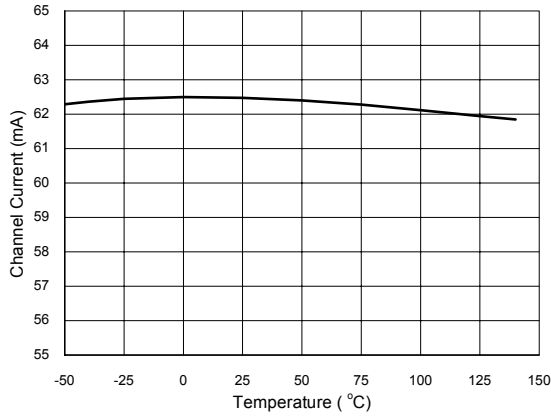

Figure 8. Channel Current vs. Temperature

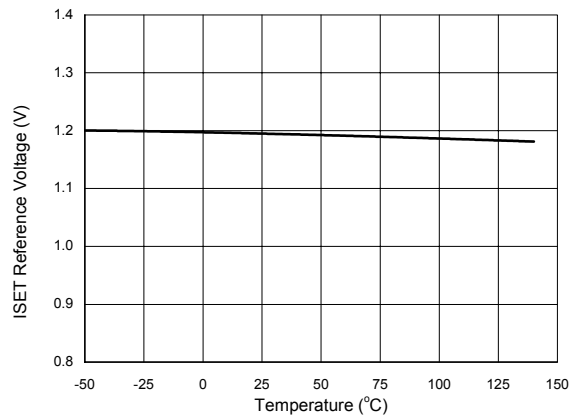

Figure 9. ISET Reference Voltage vs. Temperature

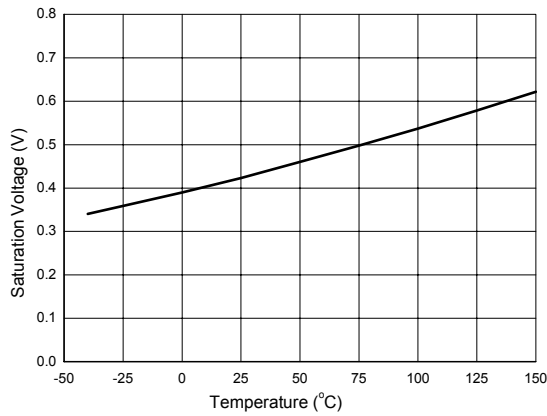

Figure 10. Saturation Voltage vs. Temperature

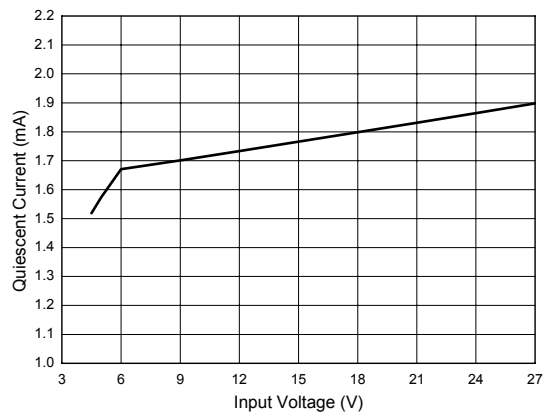

Figure 11. Quiescent Current vs. Input Voltage



SIXTEEN-CHANNEL, 75mA CURRENT SINK WITH CURRENT MATCH AP3616

Typical Performance Characteristics (Continued)

$V_{IN}=24V$, $V_{EN}=5V$, $R_{ISET}=30k\Omega$, $T_A=25^\circ C$, unless otherwise specified.

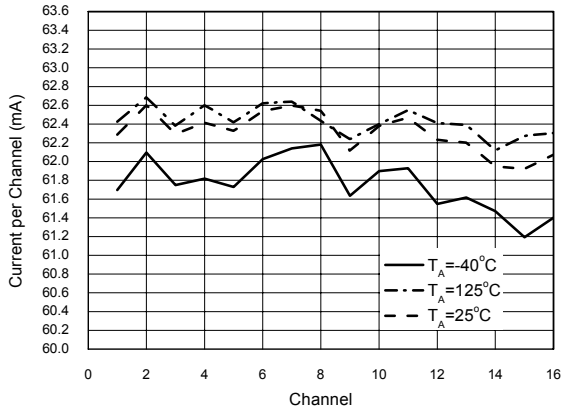

Figure 12. Current per Channel vs. Channel

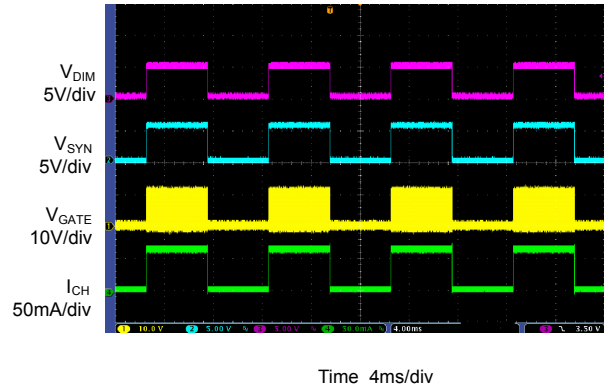

Figure 13. PWM Dimming ($f=100Hz$, Duty Cycle=50%)

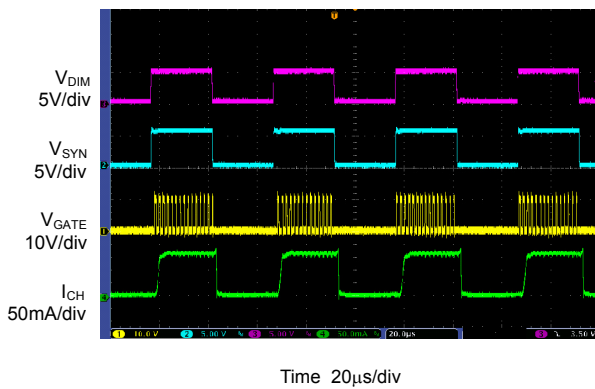

Figure 14. PWM Dimming ($f=20kHz$, Duty Cycle=50%)

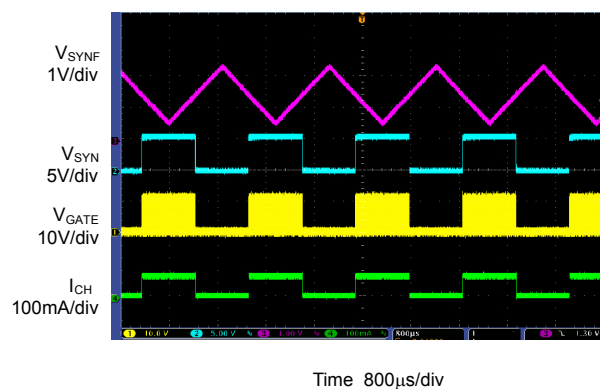
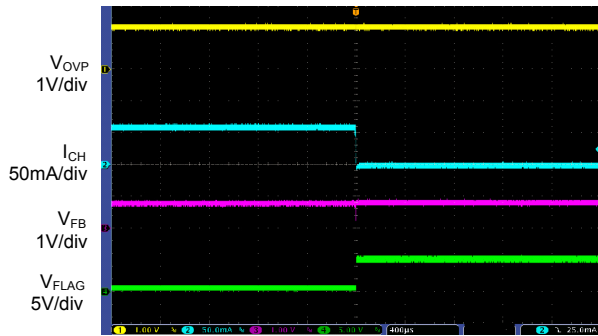

Figure 15. Linear Dimming ($V_{DIM}=1.4V$)

SIXTEEN-CHANNEL, 75mA CURRENT SINK WITH CURRENT MATCH AP3616

Typical Performance Characteristics (Continued)

$V_{IN}=24V$, $V_{EN}=5V$, $R_{ISET}=30k\Omega$, $T_A=25^\circ C$, unless otherwise specified.



Time 400µs/div

Figure 16. LED Open Protection

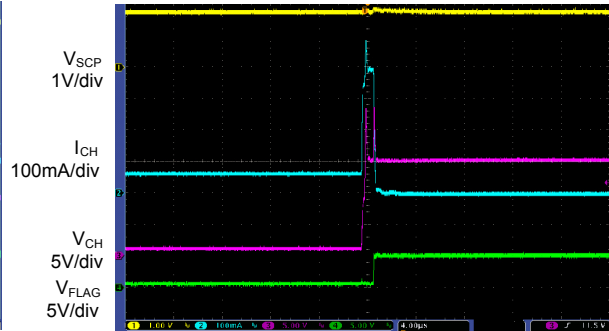

Time 4µs/div

Figure 17. LED Short Protection

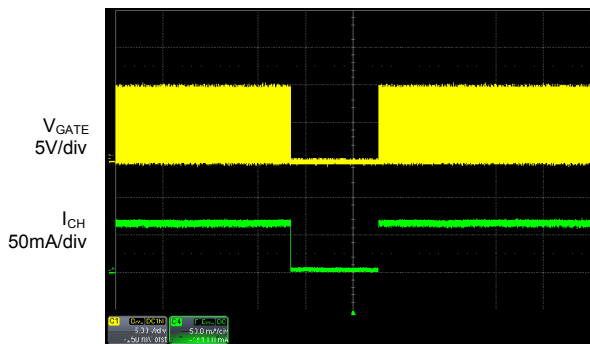

Time 2s/div

Figure 18. OTP and Recovery

**SIXTEEN-CHANNEL, 75mA CURRENT SINK WITH CURRENT MATCH AP3616****Function Description****1. LED Current Setting**

The maximum LED current per channel can be adjusted up to 75mA via ISET pin. When $\geq 75\text{mA}$ current is needed in application, two or more channels can be paralleled to provide larger drive current. Connect a resistor R_{ISET} between ISET pin and GND to set the reference current I_{SET} . The LED current is determined by the following equation.

$$I_{LED} (mA) = \frac{k \cdot V_{ISET}}{R_{ISET} (k\Omega)} = \frac{1560 \times 1.194}{R_{ISET} (k\Omega)}$$

2. Dimming Control

The AP3616 provides two dimming methods: external PWM signal or DC voltage input. Applying a PWM signal to DIM pin to adjust the LED current, that means, the LED current of all enabled channels can be adjusted at the same time and the LED brightness can be adjusted from $1\% \cdot I_{CHX_MAX}$ to $100\% \cdot I_{CHX_MAX}$. During the high level period of PWM signal, the LED is turned on and 100% of the current flows through LED, while during the low level period of the PWM signal, the LED is turned off and almost no current flows through the LED, thus changing the average current through LED and finally adjusting LED brightness. The external PWM signal frequency applied to PWM pin is allowed to be 80Hz or higher.

3. Over Voltage Protection

The AP3616 integrates an OVP circuit. The OVP pin is connected to the center tap of voltage-divider (R_{OV3} and R_{OV4}) that placed between high voltage output and GND (Figure 19). If the voltage on OVP pin exceeds 1.194V, which may results from open loop or excessive output voltage, the AP3616 will start LED open protection.

$$V_{OVP} = \frac{(R_{OV3} + R_{OV4}) \times 1.194V}{R_{OV4}}$$

4. LED Short-circuit Protection

The AP3616 integrates an LED short-circuit protection circuit. During normal operation, any short-circuited LED will cause the corresponding LED pin voltage to rise. If any LED pin voltage exceeds 8 times of the voltage at SCP pin, the corresponding LED current sink will be latched off, while the remaining string(s) keep normal operation. Toggle the VIN and/or EN to reset the latch. An internal current source was connected to this pin, a resistor connected here is used to set the shorting LED trigger voltage.

5. LED Open-circuit Protection

The AP3616 integrates an LED Open-Circuit Protection circuit. When any LED string is open, V_{OUT} will boost up until the voltage at OVP pin reaches an approximate 1.194V threshold. The IC will automatically ignore the open string(s) whose CHX pin voltage is less than 100mV.

SIXTEEN-CHANNEL, 75mA CURRENT SINK WITH CURRENT MATCH AP3616

Typical Application

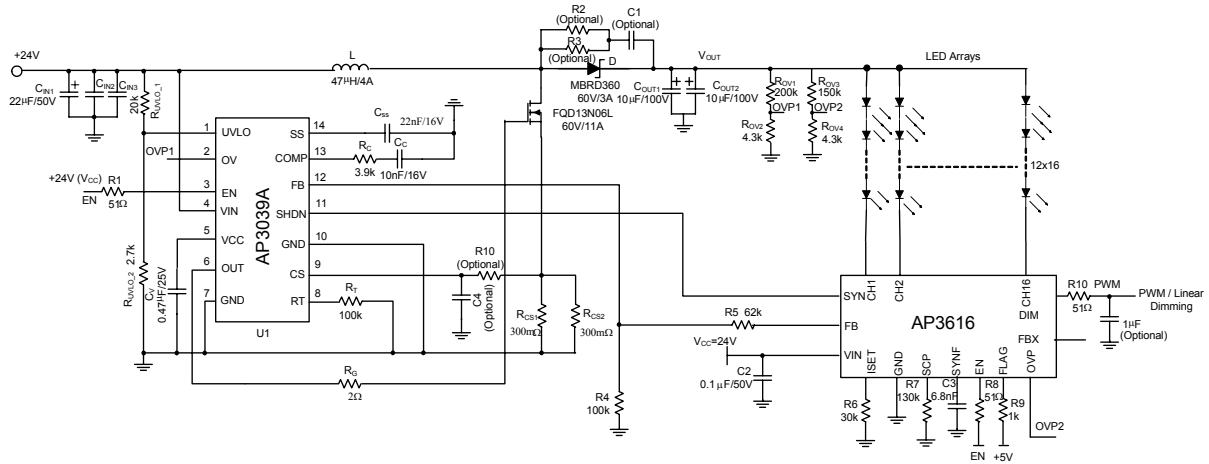

Single Chip Application (12S16P)

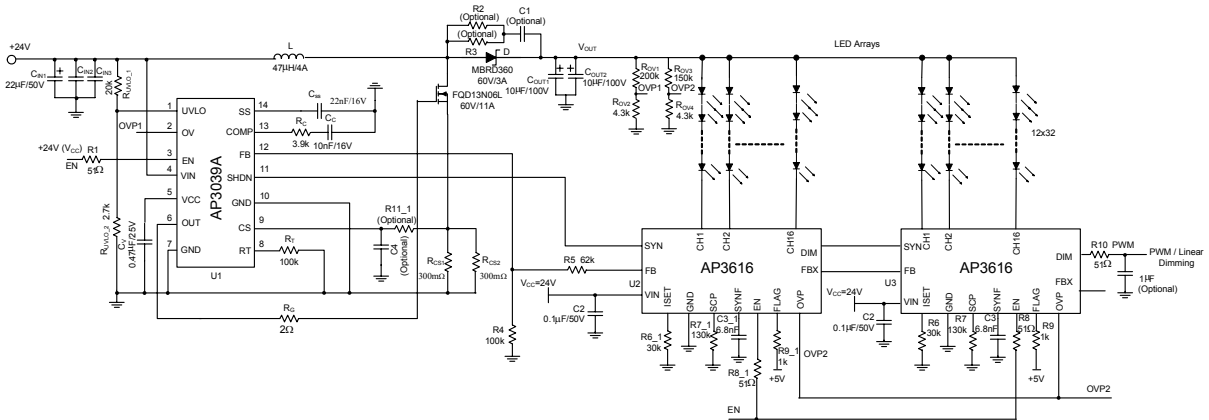

Multi Chips Application (12S32P)

Figure 19. Typical Applications of AP3616



SIXTEEN-CHANNEL, 75mA CURRENT SINK WITH CURRENT MATCH AP3616

Mechanical Dimensions

SOIC-28

Unit: mm(inch)

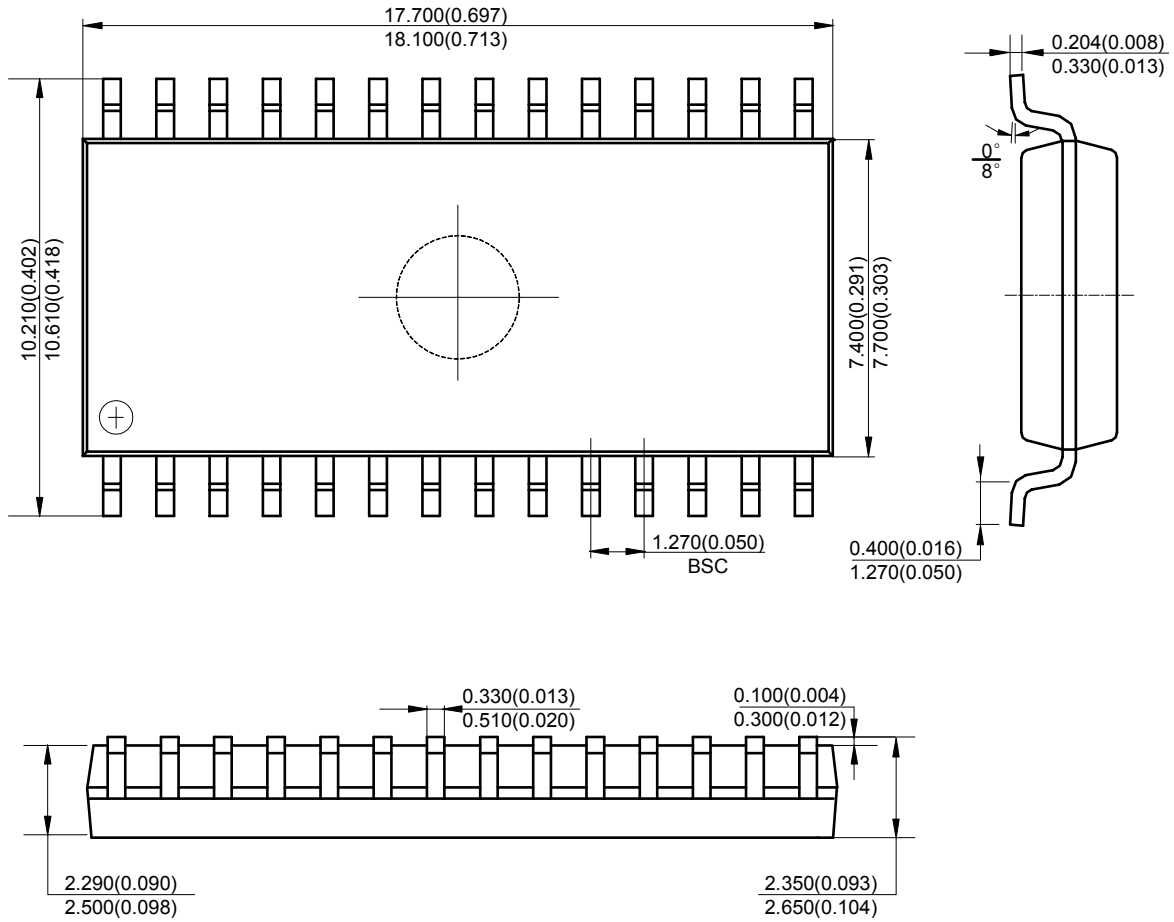

Note: Eject hole, oriented hole and mold mark is optional.



SIXTEEN-CHANNEL, 75mA CURRENT SINK WITH CURRENT MATCH AP3616

Mechanical Dimensions (Continued)

HSOP-28

Unit: mm(inch)

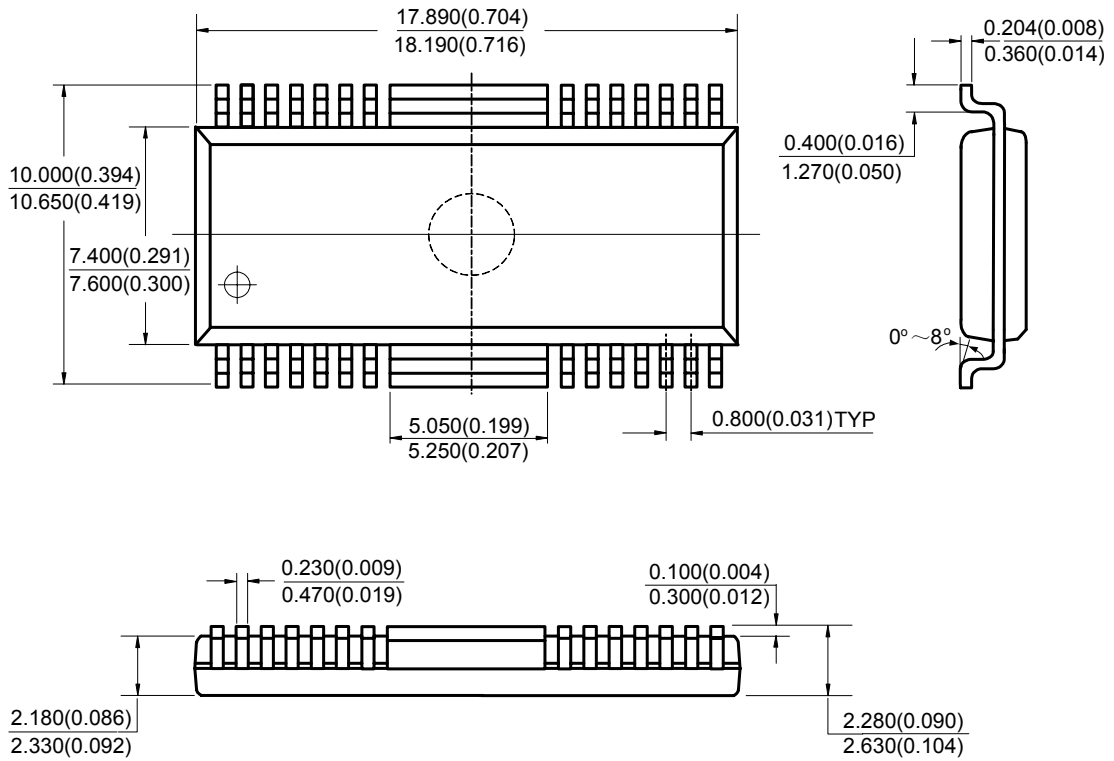

Note: Eject hole, oriented hole and mold mark is optional.



BCD Semiconductor Manufacturing Limited

<http://www.bcdsemi.com>

IMPORTANT NOTICE

BCD Semiconductor Manufacturing Limited reserves the right to make changes without further notice to any products or specifications herein. BCD Semiconductor Manufacturing Limited does not assume any responsibility for use of any its products for any particular purpose, nor does BCD Semiconductor Manufacturing Limited assume any liability arising out of the application or use of any its products or circuits. BCD Semiconductor Manufacturing Limited does not convey any license under its patent rights or other rights nor the rights of others.

MAIN SITE

- Headquarters

BCD Semiconductor Manufacturing Limited

No. 1600, Zi Xing Road, Shanghai ZiZhu Science-based Industrial Park, 200241, China
Tel: +86-21-24162266, Fax: +86-21-24162277

- Wafer Fab

Shanghai SIM-BCD Semiconductor Manufacturing Co., Ltd.

800 Yi Shan Road, Shanghai 200233, China
Tel: +86-21-6485 1491, Fax: +86-21-5450 0008

REGIONAL SALES OFFICE

Shenzhen Office

Shanghai SIM-BCD Semiconductor Manufacturing Co., Ltd., Shenzhen Office

Unit A Room 1203, Skyworth Bldg., Gaoxin Ave. 1.S., Nanshan District, Shenzhen, China
Tel: +86-755-8826 7951
Fax: +86-755-8826 7865

Taiwan Office

BCD Semiconductor (Taiwan) Company Limited

4F, 298-1, Rui Guang Road, Nei-Hu District, Taipei, Taiwan
Tel: +886-2-2656 2808
Fax: +886-2-2656 2806



USA Office

BCD Semiconductor Corp.

30920 Huntwood Ave. Hayward, CA 94544, USA
Tel : +1-510-324-2988
Fax: +1-510-324-2788

Looking for pricing, stock, or lifecycle information?

Click below to explore more details on WIN SOURCE:

-  [View AP3616M28-G1 on WIN SOURCE](#)
-  [Diodes Incorporated Information](#)

Optimize Your Supply Chain with WIN SOURCE Solutions

-  Global Sourcing Solution
-  Obsolete Management
-  Cost Control Management
-  Shortage Management
-  Alternative Solution
-  Excess Inventory Management