



**QUINT LVPECL-TO-PECL
OR PECL-TO-LVPECL
TRANSLATOR**

SY100E417

FEATURES

- 3.3V and 5V power supplies required
- Also, supports LVPECL-to-PECL translation
- 500ps propagation delays
- Fully differential design
- Differential line receiver capability
- Available in 28-pin PLCC package

BLOCK DIAGRAM

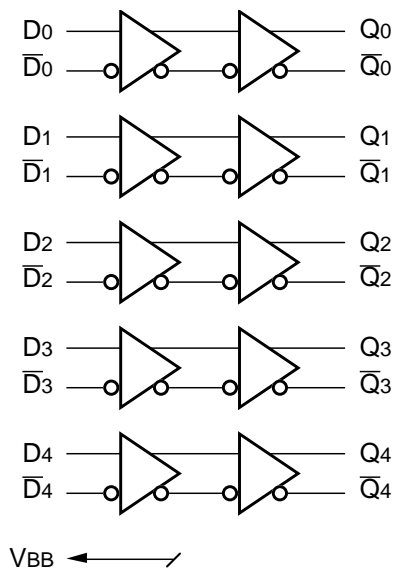

DESCRIPTION

The SY100E417 is a quint LVPECL-to-PECL translator. It can also be used as a quint PECL-to-LVPECL translator. The device receives standard PECL signals and translates them to differential LVPECL output signals (or vice versa).

The SY100E417 can also be used as a differential line receiver for PECL-to-PECL or LVPECL-to-LVPECL signals. However, please note that for the latter we will need two different power supplies. Please refer to Function Table for more details.

A VBB output is provided for interfacing single ended input signals. If a single ended input is to be used, the VBB output should be connected to the \bar{D}_n input and the active signal will drive the D_n input. When used, the VBB should be bypassed to VCC via a 0.01 μ F capacitor. The VBB is designed to act as a switching reference for the SY100E417 under single ended input conditions. As a result, the pin can only source/sink 0.5mA of current.

To accomplish the PECL-to-LVPECL level translation, the SY100E417 requires three power rails. The VCC and VCC_VBB supply is to be connected to the standard PECL supply, the 3.3V supply is to be connected to the VCCO supply, and GND is connected to the system ground plane. Both the VCC and VCCO should be bypassed to ground with a 0.01 μ F capacitor.

To accomplish the LVPECL-to-PECL level translation, the SY100E417 requires three power rails as well. The 5.0V supply is connected to the VCC and VCCO pins, 3.3V supply is connected to the VCC_VBB pin and GND is connected to the system ground plane. VCC_VBB is used to provide a proper VBB output level if a single ended input is used. VCC_VBB = 3.3V is only required for single-ended LVPECL input. For differential LVPECL input, VCC_VBB can be either 3.3V or 5.0V.

Under open input conditions, the D_n input will be biased at a $V_{CC}/2$ voltage level and the \bar{D}_n input will be pulled to GND. This condition will force the "Qn" output low, ensuring stability.

PIN NAMES

Pin	Function
D_n	PECL / LVPECL Inputs
Q_n	PECL / LVPECL Outputs
VBB	Reference Voltage Output
VCCO	Vcc for Outputs
VCC_VBB	Vcc for VBB Output
GND	Common Ground Rail
VCC	Vcc for Internal Circuitry

FUNCTION TABLE

Function	Vcc	Vcco	Vcc_VBB
PECL-to-LVPECL	5.0V	3.3V	5.0V
LVPECL-to-PECL	5.0V	5.0V	3.3V
PECL-to-PECL	5.0V	5.0V	5.0V
LVPECL-to-LVPECL	5.0V	3.3V	3.3V

PACKAGE/ORDERING INFORMATION

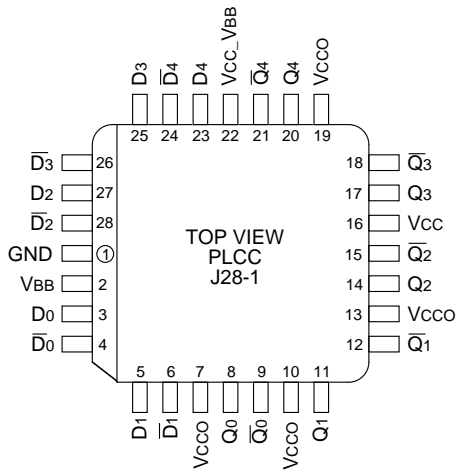

28-Pin PLCC (J28-1)

Ordering Information⁽¹⁾

Part Number	Package Type	Operating Range	Package Marking	Lead Finish
SY100E417JI	J28-1	Industrial	SY100E417JI	Sn-Pb
SY100E417JITR ⁽²⁾	J28-1	Industrial	SY100E417JI	Sn-Pb
SY100E417JC	J28-1	Commercial	SY100E417JC	Sn-Pb
SY100E417JCTR ⁽²⁾	J28-1	Commercial	SY100E417JC	Sn-Pb
SY100E417JY ⁽³⁾	J28-1	Industrial	SY100E417JY with Pb-Free bar-line indicator	Matte-Sn
SY100E417JYTR ^(2, 3)	J28-1	Industrial	SY100E417JY with Pb-Free bar-line indicator	Matte-Sn

Notes:

1. Contact factory for die availability. Dice are guaranteed at T_A = 25°C, DC Electricals only.
2. Tape and Reel.
3. Pb-Free package is recommended for new designs.

PECL INPUT DC ELECTRICAL CHARACTERISTICS

VCC_VBB = VCC = +4.5V to +5.5V

Symbol	Parameter	TA = -40°C			TA = 0°C			TA = +25°C			TA = +85°C			Unit
		Min.	Typ.	Max.	Min.	Typ.	Max.	Min.	Typ.	Max.	Min.	Typ.	Max.	
VCC	Power Supply Voltage	4.5	—	5.5	4.5	—	5.5	4.5	—	5.5	4.5	—	5.5	V
VIH	Input HIGH Voltage ⁽¹⁾	3.835	—	4.120	3.835	—	4.120	3.835	—	4.120	3.835	—	4.120	V
VIL	Input LOW Voltage ⁽¹⁾	3.190	—	3.515	3.190	—	3.525	3.190	—	3.525	3.190	—	3.525	V
VPP	Minimum Peak-to-Peak Input	150	—	—	150	—	—	150	—	—	150	—	—	mV
I _{IH}	Input HIGH Current	—	—	150	—	—	150	—	—	150	—	—	150	μA
I _{IL}	Input LOW Current $\frac{Dn}{Dn}$	0.5 -600	— —	— —	0.5 -600	— —	— —	0.5 -600	— —	— —	0.5 -600	— —	— —	μA
VBB	Output Reference ⁽¹⁾	3.620	—	3.740	3.620	—	3.740	3.620	—	3.740	3.620	—	3.740	V
I _{CC}	Power Supply Current	—	—	20	—	—	20	—	14	20	—	—	20	mA

Note:

1. These levels are for VCC_VBB = 5.0V. Level specifications will vary 1:1 with VCC_VBB.

LVPECL OUTPUT DC ELECTRICAL CHARACTERISTICS

VCC = +4.5V to +5.5V; VCCO = +3.0V to 3.8V

Symbol	Parameter	TA = -40°C			TA = 0°C			TA = +25°C			TA = +85°C			Unit
		Min.	Typ.	Max.	Min.	Typ.	Max.	Min.	Typ.	Max.	Min.	Typ.	Max.	
VCCO	Power Supply Voltage	3.0	—	3.8	3.0	—	3.8	3.0	3.3	3.8	3.0	—	3.8	V
VOH	Output HIGH Voltage ⁽¹⁾	2.215	—	2.420	2.275	—	2.420	2.275	2.350	2.420	2.275	—	2.420	V
VOL	Output LOW Voltage ⁽¹⁾	1.470	—	1.745	1.490	—	1.680	1.490	1.600	1.680	1.490	—	1.680	V
I _{CCO}	Power Supply Current	—	—	35	—	—	35	—	23	35	—	—	37	mA

Note:

1. These levels are for VCCO = 3.3V. Level specifications will vary 1:1 with VCCO.

LVPECL INPUT DC ELECTRICAL CHARACTERISTICS

VCC_VBB = +3.0V to +3.8V⁽¹⁾; VCC = +4.5V to +5.5V

Symbol	Parameter	TA = -40°C			TA = 0°C			TA = +25°C			TA = +85°C			Unit
		Min.	Typ.	Max.	Min.	Typ.	Max.	Min.	Typ.	Max.	Min.	Typ.	Max.	
VCC	Power Supply Voltage	4.5	—	5.5	4.5	—	5.5	4.5	—	5.5	4.5	—	5.5	V
VIH	Input HIGH Voltage ⁽²⁾	2.135	—	2.420	2.135	—	2.420	2.135	—	2.420	2.135	—	2.420	V
VIL	Input LOW Voltage ⁽²⁾	1.490	—	1.825	1.490	—	1.825	1.490	—	1.825	1.490	—	1.825	V
VPP	Minimum Peak-to-Peak Input	150	—	—	150	—	—	150	—	—	150	—	—	mV
I _{IH}	Input HIGH Current	—	—	150	—	—	150	—	—	150	—	—	150	μA
I _{IL}	Input LOW Current $\frac{Dn}{Dn}$	0.5 -600	— —	— —	0.5 -600	— —	— —	0.5 -600	— —	— —	0.5 -600	— —	— —	μA
VBB	Output Reference ⁽²⁾	1.92	—	2.04	1.92	—	2.04	1.92	—	2.04	1.92	—	2.04	V
I _{CC}	Power Supply Current	—	—	20	—	—	20	—	14	20	—	—	20	mA

Notes:

- VCC_VBB = 3.3V is only required for single-ended LVPECL input. For differential LVPECL input, VCC_VBB can be either 3.3V or 5V.
- These levels are for VCC_VBB = 3.3V. Level specifications will vary 1:1 with VCC_VBB.

PECL OUTPUT DC ELECTRICAL CHARACTERISTICS

VCC = VCCO = +4.5V to +5.5V

Symbol	Parameter	TA = -40°C			TA = 0°C			TA = +25°C			TA = +85°C			Unit
		Min.	Typ.	Max.	Min.	Typ.	Max.	Min.	Typ.	Max.	Min.	Typ.	Max.	
VCCO	Power Supply Voltage	4.5	—	5.5	4.5	—	5.5	4.5	—	5.5	4.5	—	5.5	V
VOH	Output HIGH Voltage ⁽¹⁾	3.915	—	4.120	3.975	—	4.120	3.975	—	4.120	3.975	—	4.120	V
VoL	Output LOW Voltage ⁽¹⁾	3.170	—	3.445	3.190	—	3.380	3.190	—	3.380	3.190	—	3.380	V
Icco	Power Supply Current	—	—	35	—	—	35	—	23	35	—	—	37	mA

Notes:

1. These levels are for VCCO = 5.0V. Level specifications will vary 1:1 with VCCO.

AC ELECTRICAL CHARACTERISTICS⁽¹⁾

Symbol	Parameter	TA = -40°C			TA = 0°C			TA = +25°C			TA = +85°C			Unit
		Min.	Typ.	Max.	Min.	Typ.	Max.	Min.	Typ.	Max.	Min.	Typ.	Max.	
tPD	Propagation Delay D to Q Diff. S.E.	410 380	510 530	610 680	410 380	510 530	610 680	410 380	510 530	610 680	410 380	510 530	610 680	ps
tskew	Within-Device Skew	—	—	—	—	—	—	—	—	—	—	—	—	ps
	Output-to-Output ⁽²⁾	—	20	100	—	20	100	—	20	100	—	20	100	
	Part-to-Part (Diff.) ⁽²⁾	—	20	200	—	20	200	—	20	200	—	20	200	
	Duty Cycle (Diff.) ⁽³⁾	—	25	—	—	25	—	—	25	—	—	25	—	
VPP	Minimum Input Swing ⁽⁴⁾	150	—	—	150	—	—	150	—	—	150	—	—	mV
VCMR	Common Mode Range ⁽⁵⁾	—	—	—	—	—	—	—	—	—	—	—	—	V
	VPP < 500mV	1.3	—	VCC-0.2	1.2	—	VCC-0.2	1.2	—	VCC-0.2	1.2	—	VCC-0.2	
	VPP ≥ 500mV	1.5	—	VCC-0.2	1.4	—	VCC-0.2	1.4	—	VCC-0.2	1.4	—	VCC-0.2	
tr tf	Output Rise/Fall Times Q (20% to 80%)	320	—	580	320	—	580	320	—	580	320	—	580	ps

Notes:

- Power supply requirements applies as indicated in the DC electrical characteristics tables.
- Skew is measured between outputs under identical transitions.
- Duty cycle skew is the difference between a TPLH and TPHL propagation delay through a device Common Mode Range.
- Minimum input swing for which AC parameters are guaranteed. The device has a DC gain of ~40.
- The CMR range is referenced to the most positive side of the differential input signal. Normal operation is obtained if the HIGH level falls within the specified range and the peak-to-peak voltage lies between VPP min. and 1V.

28-PIN PLCC (J28-1)

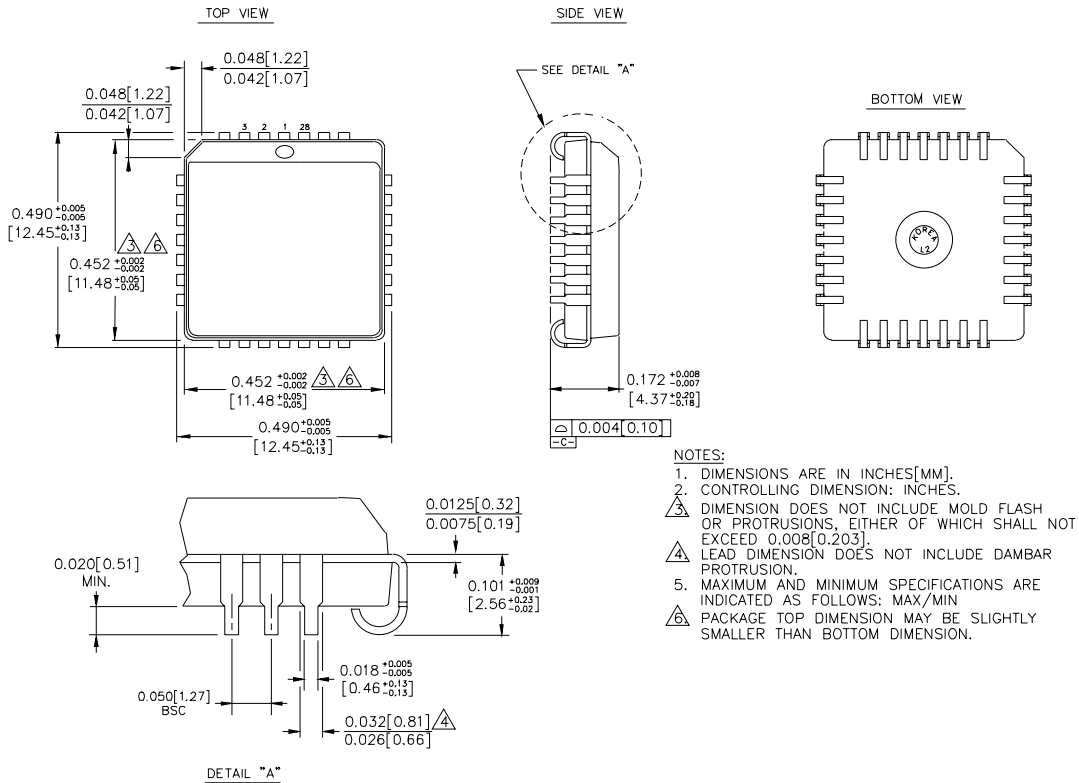

Rev. 03

MICREL, INC. 2180 FORTUNE DRIVE SAN JOSE, CA 95131 USA

TEL + 1 (408) 944-0800 FAX + 1 (408) 474-1000 WEB <http://www.micrel.com>

The information furnished by Micrel in this data sheet is believed to be accurate and reliable. However, no responsibility is assumed by Micrel for its use. Micrel reserves the right to change circuitry and specifications at any time without notification to the customer.

Micrel Products are not designed or authorized for use as components in life support appliances, devices or systems where malfunction of a product can reasonably be expected to result in personal injury. Life support devices or systems are devices or systems that (a) are intended for surgical implant into the body or (b) support or sustain life, and whose failure to perform can be reasonably expected to result in a significant injury to the user. A Purchaser's use or sale of Micrel Products for use in life support appliances, devices or systems is at Purchaser's own risk and Purchaser agrees to fully indemnify Micrel for any damages resulting from such use or sale.

© 2006 Micrel, Incorporated.

Looking for pricing, stock, or lifecycle information?

Click below to explore more details on WIN SOURCE:

- ⊖ [View SY100E417JC-TR on WIN SOURCE](#)
- ⊖ [Microchip Technology Information](#)

Optimize Your Supply Chain with WIN SOURCE Solutions

- ✓ Global Sourcing Solution
- ✓ Obsolete Management
- ✓ Cost Control Management
- ✓ Shortage Management
- ✓ Alternative Solution
- ✓ Excess Inventory Management