



**THE DATASHEET OF  
LT8610ACIMSE-1#TRPBF**



# LT8610AC/LT8610AC-1

## 42V, 3.5A Synchronous Step-Down Regulator with 2.5µA Quiescent Current

### FEATURES

- **LT8610 Feature Set, Plus:**
  - 3V Minimum Input Voltage**
  - 800mV Feedback Voltage**
  - 3.5A Maximum Output Current**
  - Fast 30ns Minimum Switch-On Time**
  - Improved Burst Mode Efficiency**
  - Improved EMI**
- **Wide Input Voltage Range: 3V to 42V**
- **Ultralow Quiescent Current Burst Mode® Operation:**  
2.5µA I<sub>Q</sub> Regulating 12V<sub>IN</sub> to 3.3V<sub>OUT</sub>
- **High Efficiency Synchronous Operation:**
  - 95% Efficiency at 1A, 5V<sub>OUT</sub> from 12V<sub>IN</sub>**
  - 93% Efficiency at 1A, 3.3V<sub>OUT</sub> from 12V<sub>IN</sub>**
- **Low Dropout Under All Conditions: 200mV at 1A**
- **Safely Tolerates Inductor Saturation in Overload**
- **Adjustable and Synchronizable Frequency:**
  - LT8610AC: 200kHz to 2.2MHz
  - LT8610AC-1: 1.5MHz to 2.2MHz
- **Accurate 1.015V Enable Pin Threshold**
- **Output Soft-Start and Tracking**
- **Small Thermally Enhanced 16-Lead MSOP Package**

### APPLICATIONS

- Automotive and Industrial Supplies
- GSM Power Supplies

### DESCRIPTION

The **LT®8610AC/LT8610AC-1** is a compact, high efficiency, high speed synchronous monolithic step-down switching regulator that consumes only 2.5µA of quiescent current. Compared to the LT8610AB, the LT8610AC/LT8610AC-1 has a lower feedback voltage of 800mV and a lower minimum V<sub>IN</sub> of 3V. The LT8610AC/LT8610AC-1 has the same additional features of the LT8610AB as compared to the LT8610: higher maximum output current of 3.5A, faster minimum on time of 30ns, and higher light load efficiency.

The LT8610AC/LT8610AC-1 has a SYNC pin for synchronization to an external clock. A capacitor on the TR/SS pin programs the output voltage ramp rate during startup. The PG flag signals when V<sub>OUT</sub> is within ±8% of the programmed output voltage as well as fault conditions. The LT8610AC-1 has internal compensation optimized for high switching frequencies resulting in improved transient response compared to the LT8610AC. The LT8610AC-1 also has a feature which will soft-start the part when exiting dropout or brownout conditions reducing output voltage overshoot.

	FEEDBACK VOLTAGE	MIN V <sub>IN</sub>	OUTPUT CURRENT	MIN ON TIME	IMPROVED EMI
LT8610AC	0.80V	3.0V	3.5A	30ns	Yes
LT8610AB*	0.97V	3.4V	3.5A	30ns	Yes
LT8610A*	0.97V	3.4V	3.5A	30ns	Yes
LT8610*	0.97V	3.4V	2.5A	50ns	–

\*See LT8610A/LT8610AB or LT8610 data sheet.

LT, LT, LTC, LTM, Burst Mode, Linear Technology and the Linear logo are registered trademarks of Linear Technology Corporation. All other trademarks are the property of their respective owners.

### TYPICAL APPLICATION

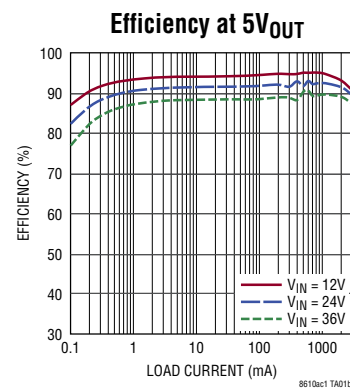
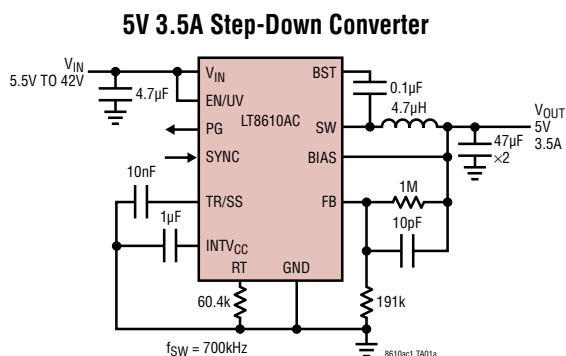

# LT8610AC/LT8610AC-1

## ABSOLUTE MAXIMUM RATINGS

(Note 1)

$V_{IN}$ , EN/UV, PG	42V
BIAS	30V
BST Pin Above SW Pin	4V
FB, TR/SS, RT, INTV <sub>CC</sub>	4V
SYNC Voltage	6V
Operating Junction Temperature Range (Note 2)	
LT8610ACE/LT8610ACE-1	-40 to 125°C
LT8610ACI/LT8610ACI-1	-40 to 125°C
LT8610ACH/LT8610ACH-1	-40 to 150°C
Storage Temperature Range	-65 to 150°C

## PIN CONFIGURATION

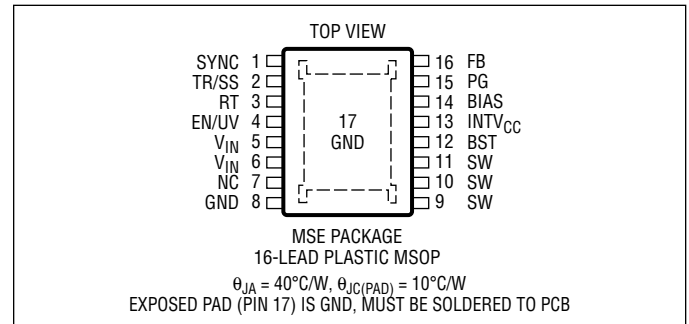

## ORDER INFORMATION

LEAD FREE FINISH	TAPE AND REEL	PART MARKING*	PACKAGE DESCRIPTION	TEMPERATURE RANGE
LT8610ACEMSE#PBF	LT8610ACEMSE#TRPBF	8610AC	16-Lead Plastic MSOP	-40°C to 125°C
LT8610ACIMSE#PBF	LT8610ACIMSE#TRPBF	8610AC	16-Lead Plastic MSOP	-40°C to 125°C
LT8610ACHMSE#PBF	LT8610ACHMSE#TRPBF	8610AC	16-Lead Plastic MSOP	-40°C to 150°C
LT8610ACEMSE-1#PBF	LT8610ACEMSE-1#TRPBF	610AC1	16-Lead Plastic MSOP	-40°C to 125°C
LT8610ACIMSE-1#PBF	LT8610ACIMSE-1#TRPBF	610AC1	16-Lead Plastic MSOP	-40°C to 125°C
LT8610ACHMSE-1#PBF	LT8610ACHMSE-1#TRPBF	610AC1	16-Lead Plastic MSOP	-40°C to 150°C

Consult LTC Marketing for parts specified with wider operating temperature ranges. \*The temperature grade is identified by a label on the shipping container. Consult LTC Marketing for information on non-standard lead based finish parts.

For more information on lead free part marking, go to: <http://www.linear.com/leadfree/>

For more information on tape and reel specifications, go to: <http://www.linear.com/tapeandreel/>

## ELECTRICAL CHARACTERISTICS

The ● denotes the specifications which apply over the full operating temperature range, otherwise specifications are at  $T_A = 25^\circ\text{C}$ .

PARAMETER	CONDITIONS	MIN	TYP	MAX	UNITS	
Minimum Input Voltage		●	2.6	3.0	V	
$V_{IN}$ Quiescent Current	$V_{EN/UV} = 0V$	●	1.0	3	$\mu\text{A}$	
		●	1.0	8	$\mu\text{A}$	
	$V_{EN/UV} = 2V$ , Not Switching, $V_{SYNC} = 0V$	●	1.7	4	$\mu\text{A}$	
		●	1.7	10	$\mu\text{A}$	
$V_{IN}$ Current in Regulation	$V_{OUT} = 0.8V$ , $V_{IN} = 6V$ , Output Load = 100 $\mu\text{A}$	●	30	60	$\mu\text{A}$	
	$V_{OUT} = 0.8V$ , $V_{IN} = 6V$ , Output Load = 1mA	●	225	500	$\mu\text{A}$	
Feedback Reference Voltage	$V_{IN} = 6V$ , $I_{LOAD} = 0.5A$	●	0.794	0.800	0.806	V
	$V_{IN} = 6V$ , $I_{LOAD} = 0.5A$	●	0.788	0.800	0.812	V
Feedback Voltage Line Regulation	$V_{IN} = 4.0V$ to 42V, $I_{LOAD} = 1A$	●	0.004	0.02	%/V	
Feedback Pin Input Current	$V_{FB} = 1V$	●	-20	20	nA	

8610acfa

## ELECTRICAL CHARACTERISTICS

The ● denotes the specifications which apply over the full operating temperature range, otherwise specifications are at  $T_A = 25^\circ\text{C}$ .

PARAMETER	CONDITIONS		MIN	TYP	MAX	UNITS
INTV <sub>CC</sub> Voltage	$I_{LOAD} = 0\text{mA}, V_{BIAS} = 0\text{V}$		3.23	3.4	3.57	V
	$I_{LOAD} = 0\text{mA}, V_{BIAS} = 3.3\text{V}$		3.25	3.29	3.35	V
INTV <sub>CC</sub> Undervoltage Lockout			2.37	2.47	2.57	V
BIAS Pin Current Consumption	$V_{BIAS} = 3.3\text{V}, I_{LOAD} = 1\text{A}, 2\text{MHz}$			9.2		mA
Minimum On-Time	$I_{LOAD} = 1\text{A}, \text{SYNC} = 0\text{V}$	●	15	30	45	ns
	$I_{LOAD} = 1\text{A}, \text{SYNC} = 3.3\text{V}$	●	15	30	45	ns
Minimum Off-Time				95	125	ns
Oscillator Frequency	$R_T = 221\text{k}, I_{LOAD} = 1\text{A}$ (LT8610AC Only)	●	180	210	240	kHz
	$R_T = 60.4\text{k}, I_{LOAD} = 1\text{A}$ (LT8610AC Only)	●	665	700	735	kHz
	$R_T = 18.2\text{k}, I_{LOAD} = 1\text{A}$ (LT8610AC/LT8610AC-1)	●	1.85	2.00	2.15	MHz
Top Power NMOS On-Resistance	$I_{SW} = 1\text{A}$			120		m $\Omega$
Top Power NMOS Current Limit		●	5	6.7	8	A
Bottom Power NMOS On-Resistance	$V_{INTVCC} = 3.4\text{V}, I_{SW} = 1\text{A}$			65		m $\Omega$
Bottom Power NMOS Current Limit	$V_{INTVCC} = 3.4\text{V}$		3.4	4.3	5.4	A
SW Leakage Current	$V_{IN} = 42\text{V}, V_{SW} = 0\text{V}, 42\text{V}$		-1.5		1.5	$\mu\text{A}$
EN/UV Pin Threshold	EN/UV Rising	●	0.955	1.015	1.075	V
EN/UV Pin Hysteresis				50		mV
EN/UV Pin Current	$V_{EN/UV} = 2\text{V}$		-20		20	nA
PG Upper Threshold Offset from $V_{FB}$	$V_{FB}$ Falling	●	5	8.0	11	%
PG Lower Threshold Offset from $V_{FB}$	$V_{FB}$ Rising	●	-11	-8.0	-5	%
PG Hysteresis				0.4		%
PG Leakage	$V_{PG} = 3.3\text{V}$		-40		40	nA
PG Pull-Down Resistance	$V_{PG} = 0.1\text{V}$	●		680	2000	$\Omega$
SYNC Threshold	SYNC Falling		0.8	1.1	1.4	V
	SYNC Rising		1.6	2.0	2.4	V
TR/SS Source Current		●	1.0	2.0	3.2	$\mu\text{A}$
TR/SS Pull-Down Resistance	Fault Condition, TR/SS = 0.1V			230		$\Omega$

**Note 1:** Stresses beyond those listed under Absolute Maximum Ratings may cause permanent damage to the device. Exposure to any Absolute Maximum Rating condition for extended periods may affect device reliability and lifetime.

**Note 2:** The LT8610ACE/LT8610ACE-1 is guaranteed to meet performance specifications from  $0^\circ\text{C}$  to  $125^\circ\text{C}$  junction temperature. Specifications over the  $-40^\circ\text{C}$  to  $125^\circ\text{C}$  operating junction temperature range are assured by design, characterization, and correlation with statistical process controls. The LT8610ACI/LT8610ACI-1 is guaranteed over the full  $-40^\circ\text{C}$  to  $125^\circ\text{C}$

operating junction temperature range. The LT8610ACH/LT8610ACH-1 is guaranteed over the full  $-40^\circ\text{C}$  to  $150^\circ\text{C}$  operating junction temperature range. High junction temperatures degrade operating lifetimes. Operating lifetime is derated at junction temperatures greater than  $125^\circ\text{C}$ .

**Note 3:** This IC includes overtemperature protection that is intended to protect the device during overload conditions. Junction temperature will exceed  $150^\circ\text{C}$  when overtemperature protection is active. Continuous operation above the specified maximum operating junction temperature will reduce lifetime.

# LT8610AC/LT8610AC-1

## TYPICAL PERFORMANCE CHARACTERISTICS $T_A = 25^\circ\text{C}$ , unless otherwise noted.

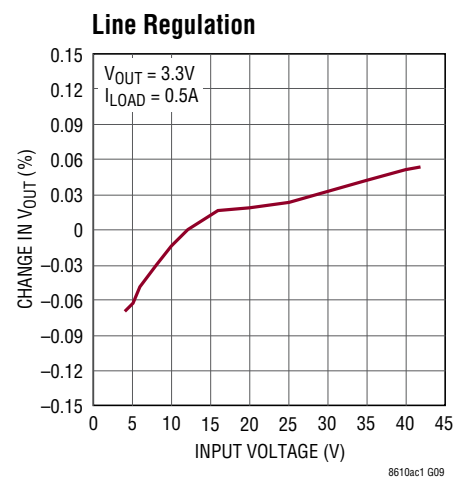
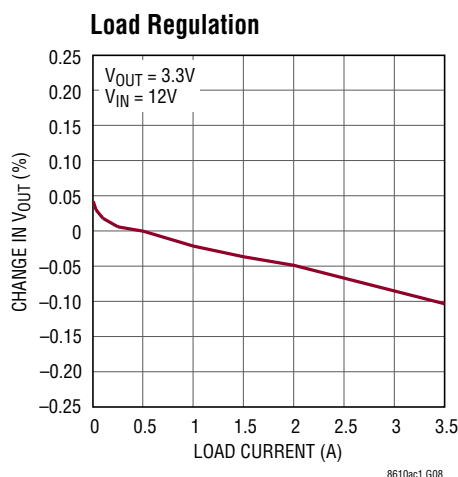
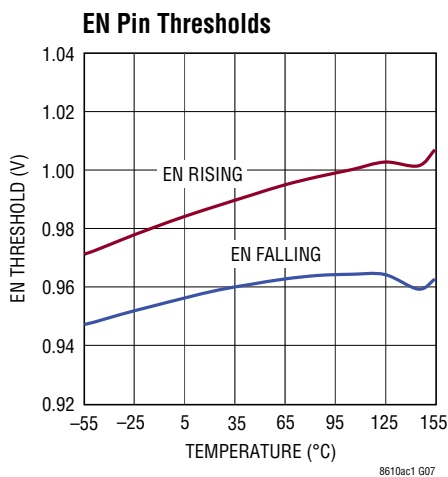
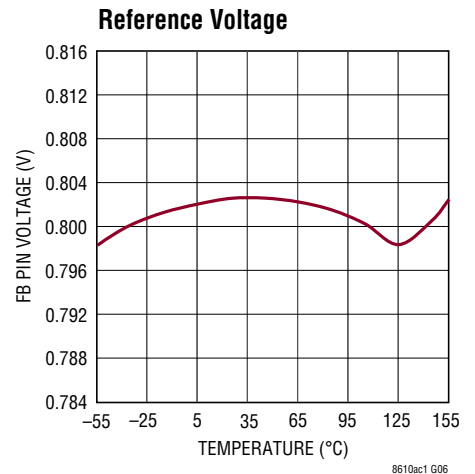
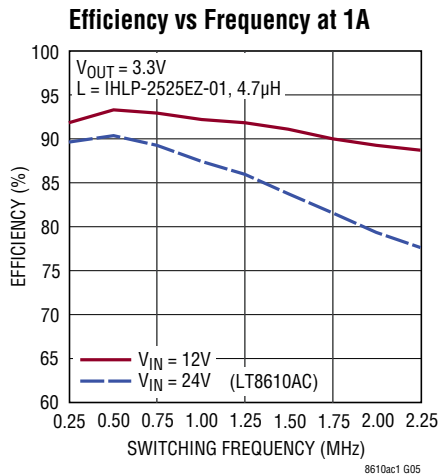
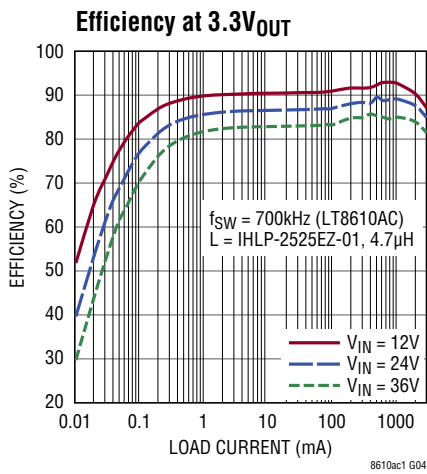
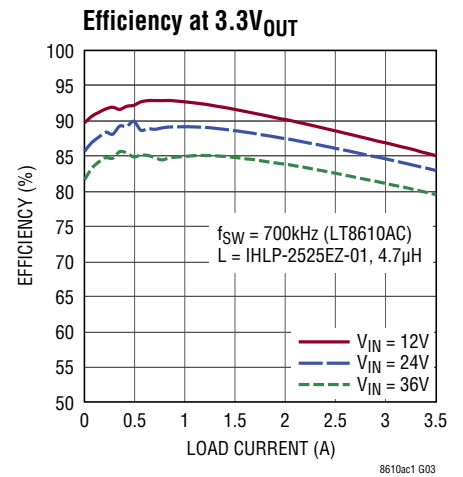
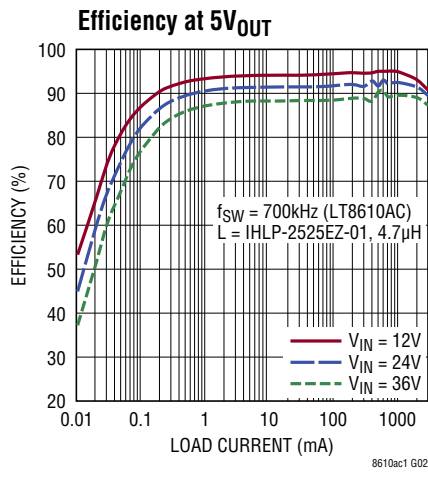
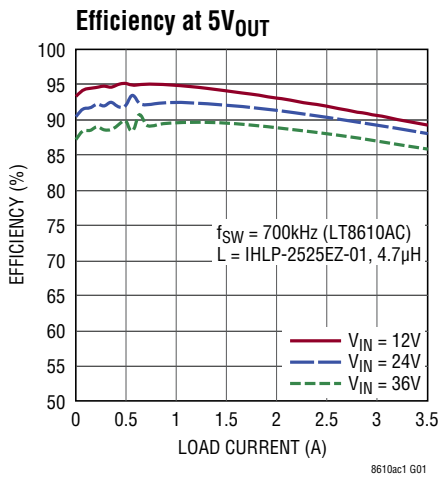

8610acfa

## TYPICAL PERFORMANCE CHARACTERISTICS $T_A = 25^\circ\text{C}$ , unless otherwise noted.

**No Load Supply Current**

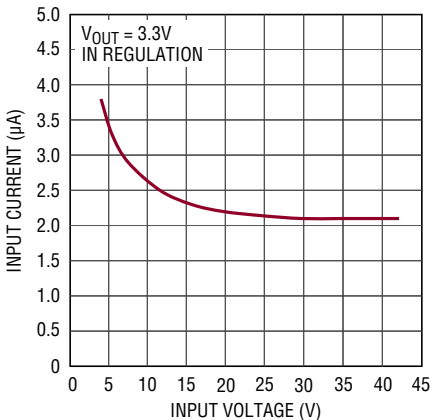

8610ac1 G10

**No Load Supply Current**

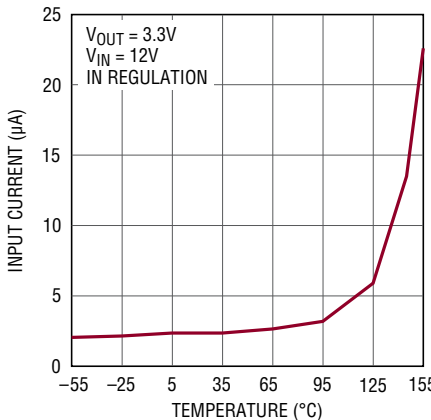

8610ac1 G11

**Top FET Current Limit vs Duty Cycle**

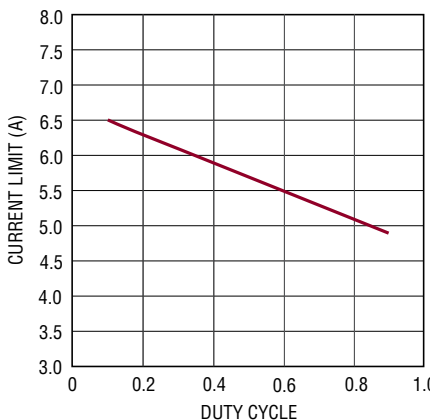

8610ac1 G12

**Top FET Current Limit**

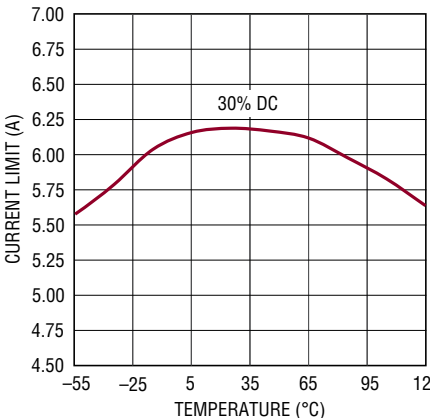

8610ac1 G13

**Bottom FET Current Limit**

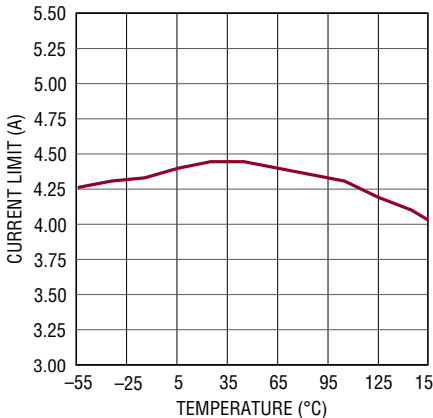

8610ac1 G14

**Switch Drop**

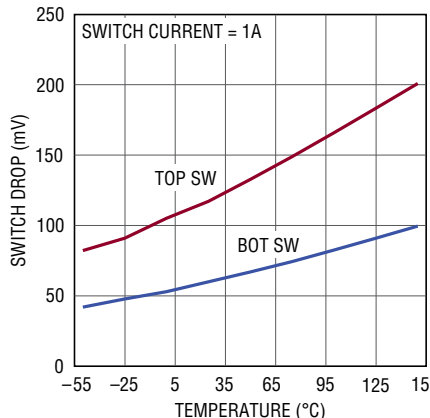

8610ac1 G15

**Switch Drop**

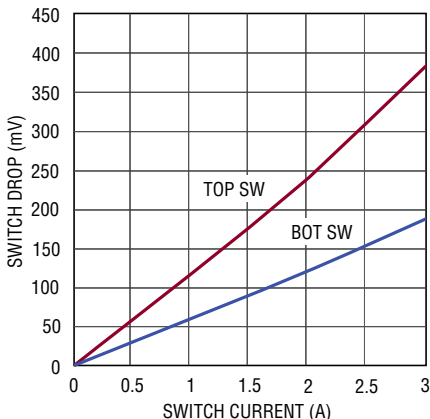

8610ac1 G16

**Minimum On-Time**

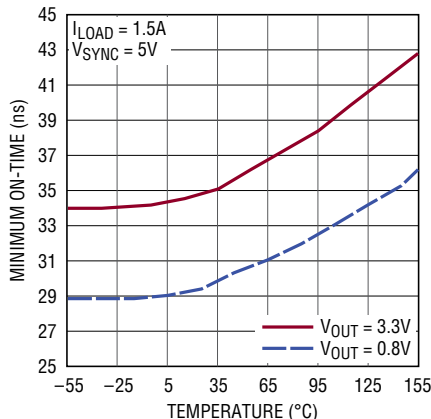

8610ac1 G17

**Minimum Off-Time**

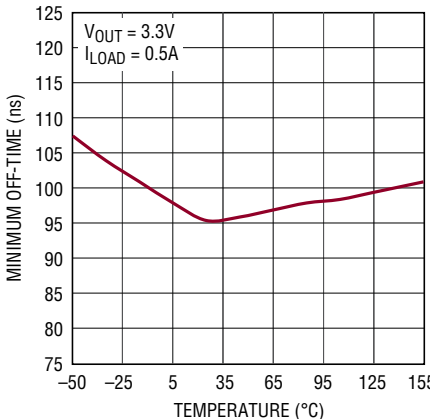

8610ac1 G18

# LT8610AC/LT8610AC-1

## TYPICAL PERFORMANCE CHARACTERISTICS $T_A = 25^\circ\text{C}$ , unless otherwise noted.

**Dropout Voltage**

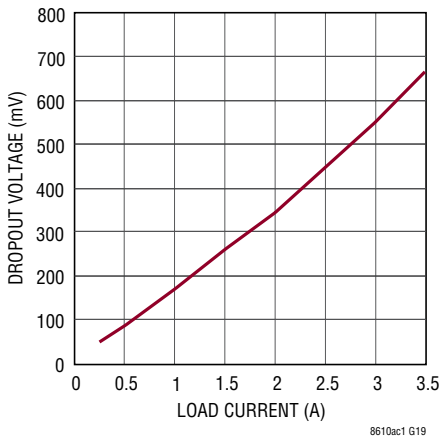

**Switching Frequency**

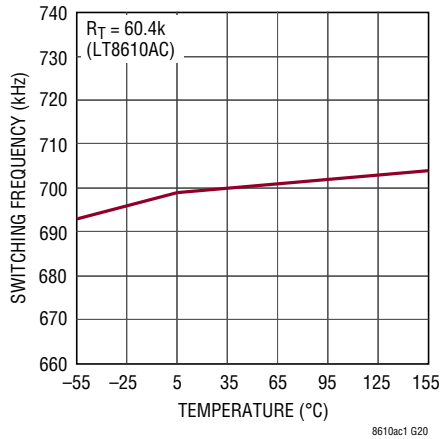

**Burst Frequency**

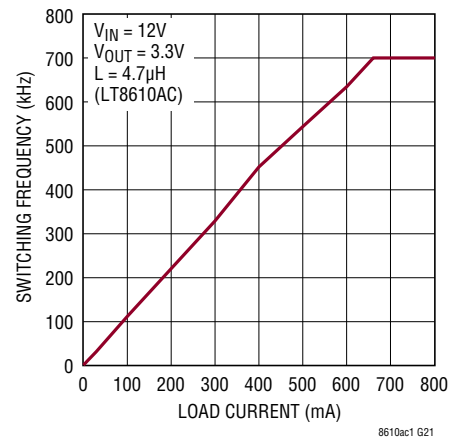

**Minimum Load to Full Frequency**

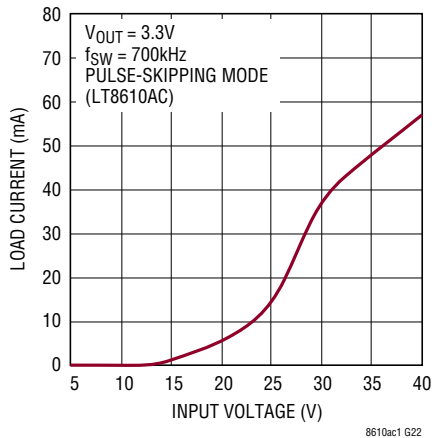

**Frequency Foldback**

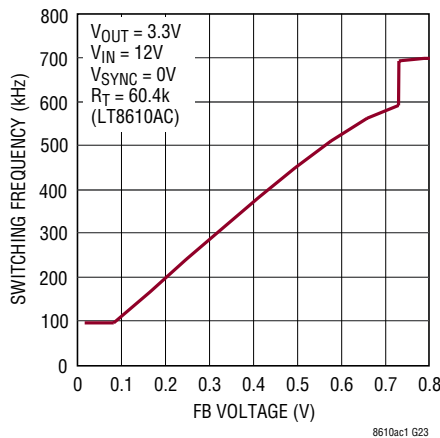

**Soft-Start Tracking**

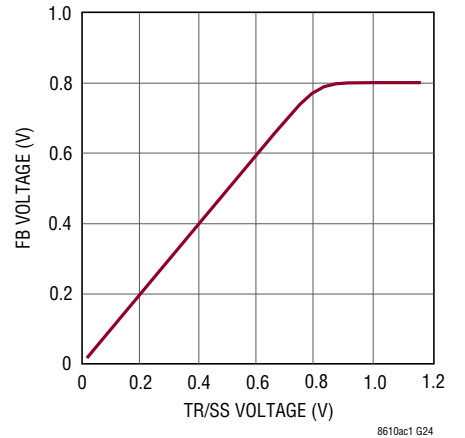

**Soft-Start Current**

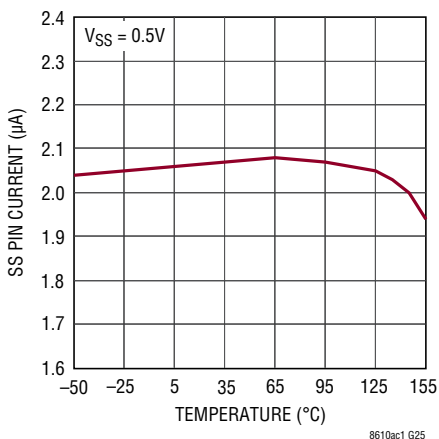

**PG High Thresholds**

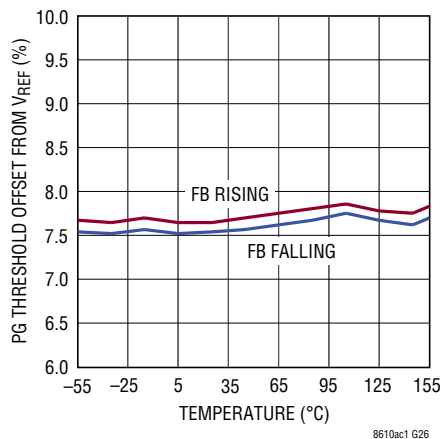

**PG Low Thresholds**

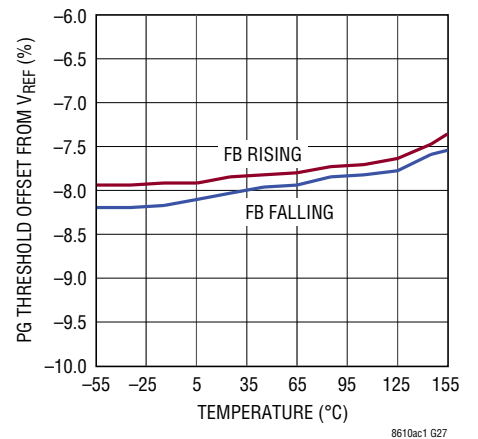

## TYPICAL PERFORMANCE CHARACTERISTICS $T_A = 25^\circ\text{C}$ , unless otherwise noted.

**RT Programmed Switching Frequency**

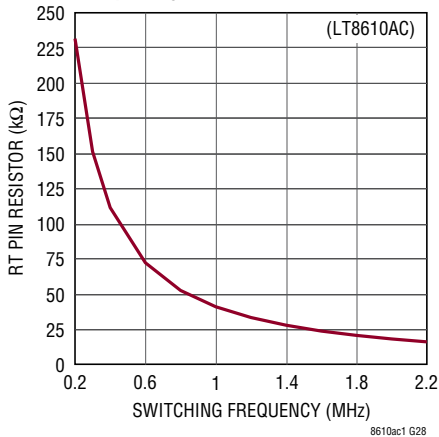

**Minimum Input Voltage**

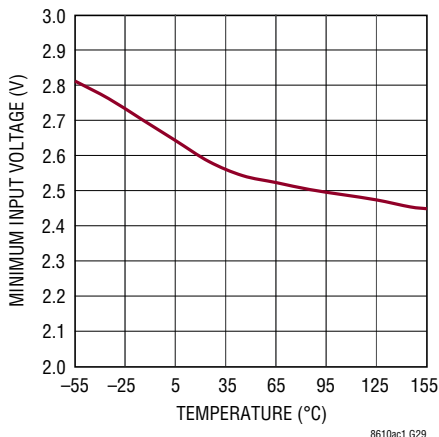

**Bias Pin Current**

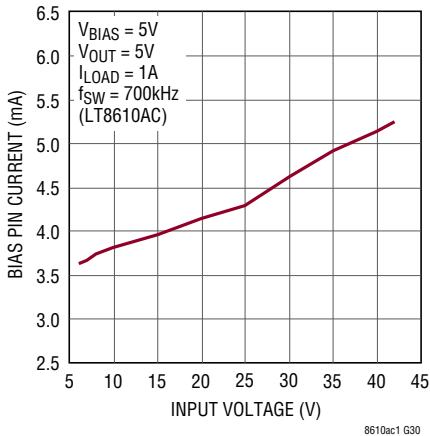

**Bias Pin Current**

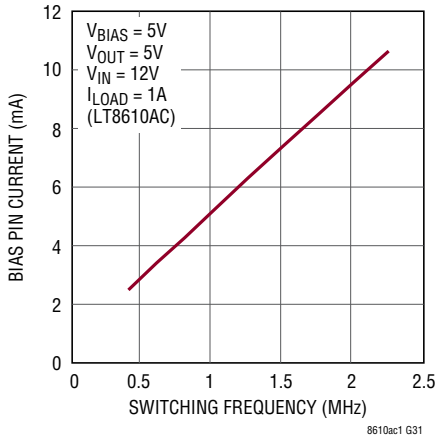

**Switching Waveforms**

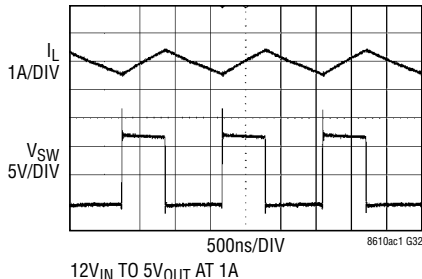

**Burst Mode Operation**

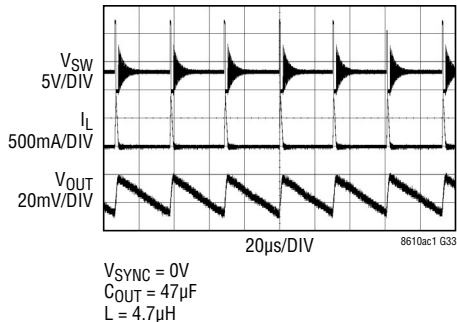

**Switching Waveforms**

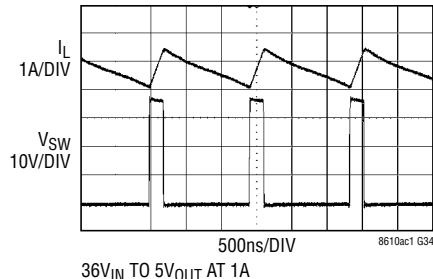

# LT8610AC/LT8610AC-1

## TYPICAL PERFORMANCE CHARACTERISTICS $T_A = 25^\circ\text{C}$ , unless otherwise noted.

### LT8610AC Transient Response

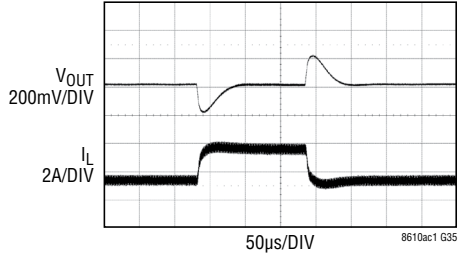

1.5A TO 3.5A TRANSIENT  
 $12\text{V}_{\text{IN}}, 3.3\text{V}_{\text{OUT}}$   
 $C_{\text{OUT}} = 47\mu\text{F} \times 2$

### LT8610AC Transient Response

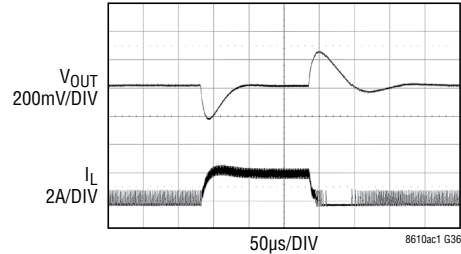

200mA TO 2A TRANSIENT  
 $12\text{V}_{\text{IN}}, 3.3\text{V}_{\text{OUT}}$   
 $C_{\text{OUT}} = 47\mu\text{F} \times 2$

### Start-Up Dropout Performance

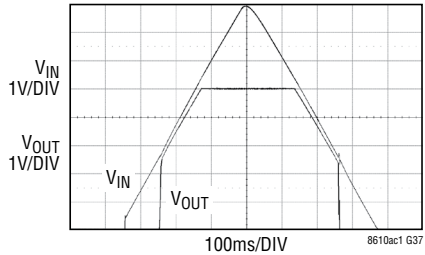

$2.5\Omega$  LOAD  
(2A IN REGULATION)

### Start-Up Dropout Performance

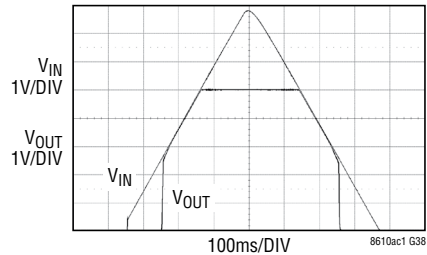

$20\Omega$  LOAD  
(250mA IN REGULATION)

### LT8610AC-1 Transient Response

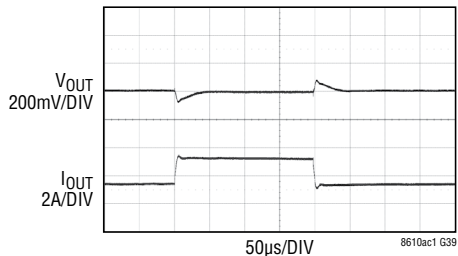

1.5A TO 3.5A TRANSIENT  
 $12\text{V}_{\text{IN}}, 3.3\text{V}_{\text{OUT}}$   
 $C_{\text{OUT}} = 47\mu\text{F} \times 2$

### LT8610AC-1 Transient Response

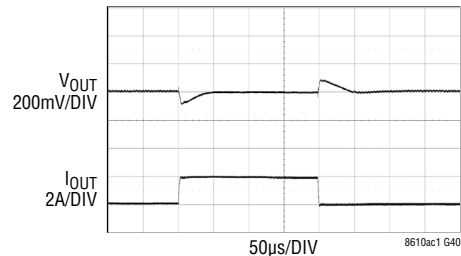

100mA TO 2A TRANSIENT  
 $12\text{V}_{\text{IN}}, 3.3\text{V}_{\text{OUT}}$   
 $C_{\text{OUT}} = 47\mu\text{F} \times 2$

## PIN FUNCTIONS

**SYNC (Pin 1):** External Clock Synchronization Input. Ground this pin for low ripple Burst Mode operation at low output loads. Tie to a clock source for synchronization to an external frequency. Apply a DC voltage of 3V or higher or tie to  $INTV_{CC}$  for pulse-skipping mode. When in pulse-skipping mode, the  $I_Q$  will increase to several hundred  $\mu A$ . Do not float this pin.

**TR/SS (Pin 2):** Output Tracking and Soft-Start Pin. This pin allows user control of output voltage ramp rate during start-up. A TR/SS voltage below 0.8V forces the LT8610AC/LT8610AC-1 to regulate the FB pin to equal the TR/SS pin voltage. When TR/SS is above 0.8V, the tracking function is disabled and the internal reference resumes control of the error amplifier. An internal  $2.2\mu A$  pull-up current from  $INTV_{CC}$  on this pin allows a capacitor to program output voltage slew rate. This pin is pulled to ground with an internal  $230\Omega$  MOSFET during shutdown and fault conditions; use a series resistor if driving from a low impedance output. This pin may be left floating in the LT8610AC if the tracking function is not needed. A minimum of  $100pF$  of external capacitance must be used on the LT8610AC-1.

**RT (Pin 3):** A resistor is tied between RT and ground to set the switching frequency.

**EN/UV (Pin 4):** The LT8610AC/LT8610AC-1 is shut down when this pin is low and active when this pin is high. The hysteric threshold voltage is 1.015V going up and 0.97V going down. Tie to  $V_{IN}$  if the shutdown feature is not used. An external resistor divider from  $V_{IN}$  can be used to program a  $V_{IN}$  threshold below which the LT8610AC/LT8610AC-1 will shut down.

**$V_{IN}$  (Pins 5, 6):** The  $V_{IN}$  pins supply current to the LT8610AC/LT8610AC-1 internal circuitry and to the internal topside power switch. These pins must be tied together and be locally bypassed. Be sure to place the positive terminal of the input capacitor as close as possible to the  $V_{IN}$  pins, and the negative capacitor terminal as close as possible to the GND pins.

**NC (Pin 7):** No Connect. This pin is not connected to internal circuitry.

**SW (Pins 9, 10, 11):** The SW pins are the outputs of the internal power switches. Tie these pins together and connect them to the inductor and boost capacitor. This node should be kept small on the PCB for good performance.

**BST (Pin 12):** This pin is used to provide a drive voltage, higher than the input voltage, to the topside power switch. Place a  $0.1\mu F$  boost capacitor as close as possible to the IC.

**$INTV_{CC}$  (Pin 13):** Internal 3.4V Regulator Bypass Pin. The internal power drivers and control circuits are powered from this voltage.  $INTV_{CC}$  maximum output current is 20mA. Do not load the  $INTV_{CC}$  pin with external circuitry.  $INTV_{CC}$  current will be supplied from BIAS if  $V_{BIAS} > 3.1V$ , otherwise current will be drawn from  $V_{IN}$ . Voltage on  $INTV_{CC}$  will vary between 2.8V and 3.4V when  $V_{BIAS}$  is between 3.0V and 3.6V. Decouple this pin to power ground with at least a  $1\mu F$  low ESR ceramic capacitor placed close to the IC.

**BIAS (Pin 14):** The internal regulator will draw current from BIAS instead of  $V_{IN}$  when BIAS is tied to a voltage higher than 3.1V. For output voltages of 3.3V and above this pin should be tied to  $V_{OUT}$ . If this pin is tied to a supply other than  $V_{OUT}$  use a  $1\mu F$  local bypass capacitor on this pin.

**PG (Pin 15):** The PG pin is the open-drain output of an internal comparator. PG remains low until the FB pin is within  $\pm 8\%$  of the final regulation voltage, and there are no fault conditions. PG is valid when  $V_{IN}$  is above 3.0V, regardless of EN/UV pin state.

**FB (Pin 16):** The LT8610AC/LT8610AC-1 regulates the FB pin to 0.800V. Connect the feedback resistor divider tap to this pin. Also, connect a phase lead capacitor between FB and  $V_{OUT}$ . Typically, this capacitor is  $4.7pF$  to  $10pF$ .

**GND (Pin 8, Exposed Pad Pin 17):** Ground. These pins are the return path of the internal bottom-side switch and must be tied together. Place the negative terminal of the input capacitor as close to the GND pin and exposed pad as possible. The exposed pad must be soldered to the PCB in order to lower the thermal resistance.

# LT8610AC/LT8610AC-1

## BLOCK DIAGRAM

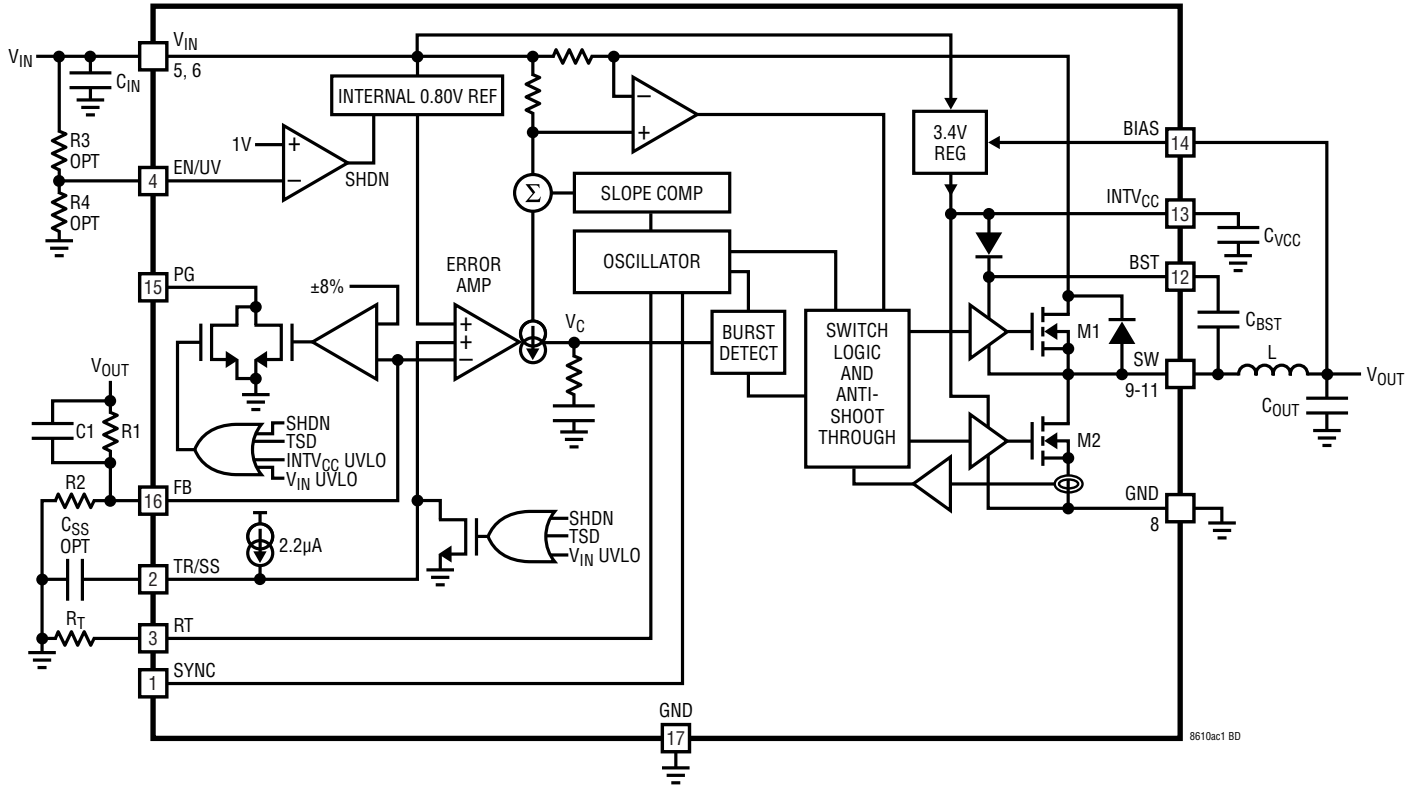

8610acfa

## OPERATION

The LT8610AC/LT8610AC-1 is a monolithic, constant frequency, current mode step-down DC/DC converter. An oscillator, with frequency set using a resistor on the RT pin, turns on the internal top power switch at the beginning of each clock cycle. Current in the inductor then increases until the top switch current comparator trips and turns off the top power switch. The peak inductor current at which the top switch turns off is controlled by the voltage on the internal VC node. The error amplifier servos the VC node by comparing the voltage on the  $V_{FB}$  pin with an internal 0.8V reference. When the load current increases it causes a reduction in the feedback voltage relative to the reference leading the error amplifier to raise the VC voltage until the average inductor current matches the new load current. When the top power switch turns off, the synchronous power switch turns on until the next clock cycle begins or inductor current falls to zero. If overload conditions result in more than 4.3A flowing through the bottom switch, the next clock cycle will be delayed until switch current returns to a safe level.

If the EN/UV pin is low, the LT8610AC/LT8610AC-1 is shut down and draws 1 $\mu$ A from the input. When the EN/UV pin is above 1.015V, the switching regulator will become active.

To optimize efficiency at light loads, the LT8610AC/LT8610AC-1 operates in Burst Mode operation in light load situations. Between bursts, all circuitry associated with controlling the output switch is shut down, reducing the input supply current to 1.7 $\mu$ A. In a typical application, 2.5 $\mu$ A will be consumed from the input supply when regulating with no load. The SYNC pin is tied low to use Burst Mode operation and can be tied to a logic high to use pulse-skipping mode. If a clock is applied to the SYNC pin the part will synchronize to an external clock frequency and operate in pulse-skipping mode. While in pulse-skipping mode the oscillator operates continuously and positive SW transitions are aligned to the clock. During light loads, switch pulses are skipped to regulate the output and the quiescent current will be several hundred  $\mu$ A.

To improve efficiency across all loads, supply current to internal circuitry can be sourced from the BIAS pin when biased at 3.3V or above. Else, the internal circuitry will draw current from  $V_{IN}$ . The BIAS pin should be connected to  $V_{OUT}$  if the LT8610AC/LT8610AC-1 output is programmed at 3.3V or above.

Comparators monitoring the FB pin voltage will pull the PG pin low if the output voltage varies more than  $\pm 8\%$  (typical) from the set point, or if a fault condition is present.

The oscillator reduces the LT8610AC/LT8610AC-1's operating frequency when the voltage at the FB pin is low. This frequency foldback helps to control the inductor current when the output voltage is lower than the programmed value which occurs during start-up or overcurrent conditions. When a clock is applied to the SYNC pin or the SYNC pin is held DC high, the frequency foldback is disabled and the switching frequency will slow down only during overcurrent conditions.

The LT8610AC-1 differs from the LT8610AC in that the internal compensation is optimized for higher switching frequency operation and a TR/SS pin discharge circuit is added to reduce output voltage overshoot when exiting dropout or brownout conditions. The internal compensation change increases the bandwidth of the control loop, which improves transient response. As a consequence the minimum programmable switching frequency of the LT8610AC-1 is increased to 1.5MHz. The SS discharge circuit regulates the TR/SS pin to the same voltage as the FB pin during dropout or brownout. This feature provides some soft-starting when the part exits dropout or brownout which reduces output voltage overshoot. Both of these changes are intended to reduce output voltage overshoot in 2MHz switching frequency applications.

## APPLICATIONS INFORMATION

### Achieving Ultralow Quiescent Current

To enhance efficiency at light loads, the LT8610AC/LT8610AC-1 operates in low ripple Burst Mode operation, which keeps the output capacitor charged to the desired output voltage while minimizing the input quiescent current and minimizing output voltage ripple. In Burst Mode operation the LT8610AC/LT8610AC-1 delivers single pulses of current to the output capacitor followed by sleep periods where the output power is supplied by the output capacitor. While in sleep mode the LT8610AC/LT8610AC-1 consumes 1.7 $\mu$ A.

As the output load decreases, the frequency of single current pulses decreases (see Figure 1a) and the percentage of time the LT8610AC/LT8610AC-1 is in sleep mode increases, resulting in much higher light load efficiency than for typi-

cal converters. By maximizing the time between pulses, the converter quiescent current approaches 2.5 $\mu$ A for a typical application when there is no output load. Therefore, to optimize the quiescent current performance at light loads, the current in the feedback resistor divider must be minimized as it appears to the output as load current.

While in Burst Mode operation the current limit of the top switch is approximately 1.3A for the LT8610AC/LT8610AC-1 resulting in output voltage ripple shown in Figure 2. An increase in output capacitance proportionally decreases the output voltage ripple (Table 1). As load ramps upward from zero the switching frequency will increase but only up to the switching frequency programmed by the resistor at the RT pin as shown in Figure 1a. The output load at which the LT8610AC/LT8610AC-1 reaches the

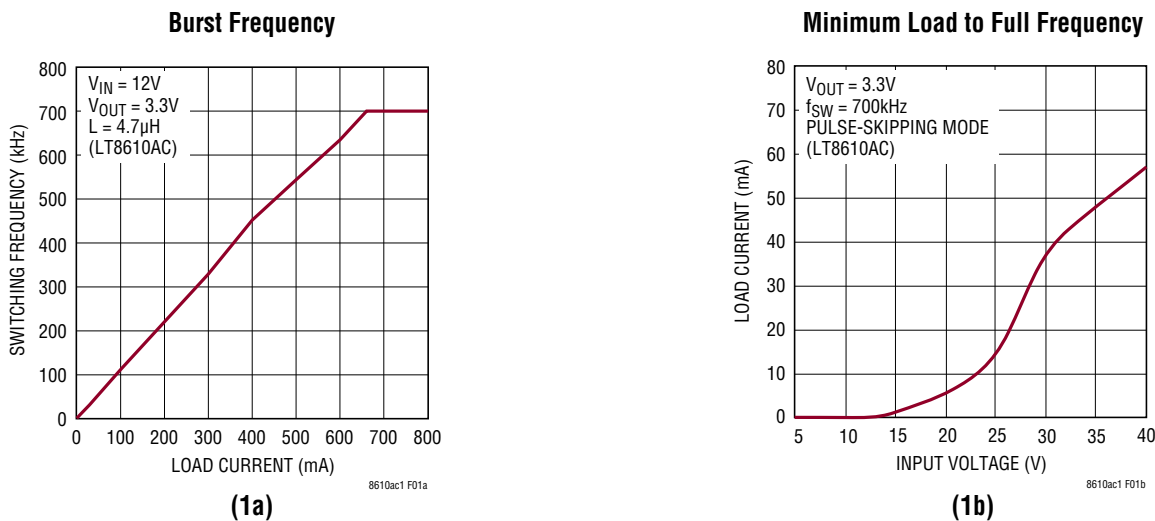

Figure 1. SW Frequency vs Load Information in Burst Mode Operation (1a) and Pulse-Skipping Mode (1b)

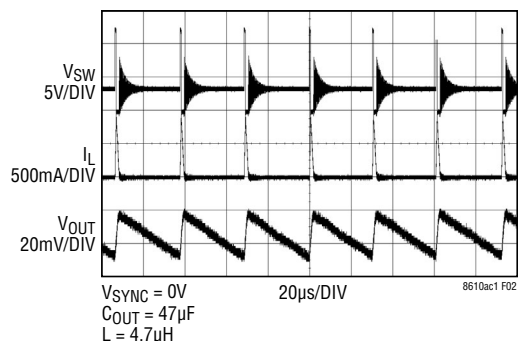

Figure 2. Burst Mode Operation

## APPLICATIONS INFORMATION

programmed frequency varies based on input voltage, output voltage, and inductor choice.

Inductor value has a very strong effect on Burst Mode efficiency. Larger value inductors allow more charge to be transferred to the output per pulse, which increases both efficiency and output voltage ripple. If higher efficiency is needed in a Burst Mode application, increasing inductor value can be a quick solution.

**Table 1. Output Voltage Ripple vs Output Capacitance for LT8610AC when  $V_{IN} = 12V$ ,  $V_{OUT} = 3.3V$ , and  $L = 4.7\mu H$**

OUTPUT CAPACITANCE	OUTPUT RIPPLE
47 $\mu$ F	40mV
47 $\mu$ F $\times$ 2	20mV
47 $\mu$ F $\times$ 4	10mV

For some applications it is desirable for the LT8610AC/LT8610AC-1 to operate in pulse-skipping mode, offering two major differences from Burst Mode operation. First is the clock stays awake at all times and all switching cycles are aligned to the clock. In this mode much of the internal circuitry is awake at all times, increasing quiescent current to several hundred  $\mu$ A. Second is that full switching frequency is reached at lower output load than in Burst Mode operation (see Figure 1b). To enable pulse-skipping mode, the SYNC pin is tied high either to a logic output or to the INTV<sub>CC</sub> pin. When a clock is applied to the SYNC pin the LT8610AC/LT8610AC-1 will also operate in pulse-skipping mode.

### FB Resistor Network

The output voltage is programmed with a resistor divider between the output and the FB pin. Choose the resistor values according to:

$$R1 = R2 \left( \frac{V_{OUT}}{0.80V} - 1 \right) \quad (1)$$

Reference designators refer to the Block Diagram. 1% resistors are recommended to maintain output voltage accuracy.

If low input quiescent current and good light-load efficiency are desired, use large resistor values for the FB resistor divider. The current flowing in the divider acts as a load current, and will increase the no-load input current to the converter, which is approximately:

$$I_Q = 1.7\mu A + \left( \frac{V_{OUT}}{R1+R2} \right) \left( \frac{V_{OUT}}{V_{IN}} \right) \left( \frac{1}{n} \right) \quad (2)$$

where 1.7 $\mu$ A is the quiescent current of the LT8610AC/LT8610AC-1 and the second term is the current in the feedback divider reflected to the input of the buck operating at its light load efficiency n. For a 3.3V application with R1 = 1M and R2 = 316k, the feedback divider draws 2.5 $\mu$ A. With  $V_{IN} = 12V$  and n = 80%, this adds 0.8 $\mu$ A to the 1.7 $\mu$ A quiescent current resulting in 2.5 $\mu$ A no-load current from the 12V supply. Note that this equation implies that the no-load current is a function of  $V_{IN}$ ; this is plotted in the Typical Performance Characteristics section.

When using large FB resistors, a 4.7pF to 10pF phase-lead capacitor should be connected from  $V_{OUT}$  to FB.

### Setting the Switching Frequency

The LT8610AC uses a constant frequency PWM architecture that can be programmed to switch from 200kHz to 2.2MHz by using a resistor tied from the RT pin to ground. A table showing the necessary  $R_T$  value for a desired switching frequency is in Table 2A. The LT8610AC-1 can be programmed to switch from 1.5MHz to 2.2MHz. The minimum allowed programmable switching frequency is higher for the LT8610AC-1 compared to the LT8610AC because the LT8610AC-1 has internal compensation which is optimized for higher switching frequencies to improve transient response by increasing control loop bandwidth. A table showing the necessary  $R_T$  value for a desired switching frequency is shown in Table 2B.

The  $R_T$  resistor required for a desired switching frequency can be calculated using:

$$R_T = \frac{46.5}{f_{SW}} - 5.2 \quad (3)$$

where  $R_T$  is in k $\Omega$  and  $f_{SW}$  is the desired switching frequency in MHz.

## APPLICATIONS INFORMATION

**Table 2A. LT8610AC SW Frequency vs R<sub>T</sub> Value**

f <sub>SW</sub> (MHz)	R <sub>T</sub> (kΩ)
0.2	232
0.3	150
0.4	110
0.5	88.7
0.6	71.5
0.7	60.4
0.8	52.3
1.0	41.2
1.2	33.2
1.4	28.0
1.6	23.7
1.8	20.5
2.0	18.2
2.2	15.8

**Table 2B. LT8610AC-1 SW Frequency vs R<sub>T</sub> Value**

f <sub>SW</sub> (MHz)	R <sub>T</sub> (kΩ)
1.4	28.0
1.6	23.7
1.8	20.5
2.0	18.2
2.2	15.8

### Operating Frequency Selection and Trade-Offs

Selection of the operating frequency is a trade-off between efficiency, component size, and input voltage range. The advantage of high frequency operation is that smaller inductor and capacitor values may be used. The disadvantages are lower efficiency and a smaller input voltage range.

The highest switching frequency (f<sub>SW(MAX)</sub>) for a given application can be calculated as follows:

$$f_{SW(MAX)} = \frac{V_{OUT} + V_{SW(BOT)}}{t_{ON(MIN)} (V_{IN} - V_{SW(TOP)} + V_{SW(BOT)})} \quad (4)$$

where V<sub>IN</sub> is the typical input voltage, V<sub>OUT</sub> is the output voltage, V<sub>SW(TOP)</sub> and V<sub>SW(BOT)</sub> are the internal switch drops (~0.42V, ~0.21V, respectively at maximum load) and t<sub>ON(MIN)</sub> is the minimum top switch on-time (see the Electrical Characteristics). This equation shows that a

slower switching frequency is necessary to accommodate a high V<sub>IN</sub>/V<sub>OUT</sub> ratio.

For transient operation, V<sub>IN</sub> may go as high as the absolute maximum rating of 42V regardless of the R<sub>T</sub> value, however the LT8610AC/LT8610AC-1 will reduce switching frequency as necessary to maintain control of inductor current to assure safe operation.

The LT8610AC/LT8610AC-1 is capable of a maximum duty cycle of greater than 99%, and the V<sub>IN</sub>-to-V<sub>OUT</sub> dropout is limited by the R<sub>DS(ON)</sub> of the top switch. In this mode the LT8610AC/LT8610AC-1 skips switch cycles, resulting in a lower switching frequency than programmed by R<sub>T</sub>.

For applications that cannot allow deviation from the programmed switching frequency at low V<sub>IN</sub>/V<sub>OUT</sub> ratios use the following formula to set switching frequency:

$$V_{IN(MIN)} = \frac{V_{OUT} + V_{SW(BOT)}}{1 - f_{SW} \cdot t_{OFF(MIN)}} - V_{SW(BOT)} + V_{SW(TOP)} \quad (5)$$

where V<sub>IN(MIN)</sub> is the minimum input voltage without skipped cycles, V<sub>OUT</sub> is the output voltage, V<sub>SW(TOP)</sub> and V<sub>SW(BOT)</sub> are the internal switch drops (~0.42V, ~0.21V, respectively at maximum load), f<sub>SW</sub> is the switching frequency (set by R<sub>T</sub>), and t<sub>OFF(MIN)</sub> is the minimum switch off-time. Note that higher switching frequency will increase the minimum input voltage below which cycles will be dropped to achieve higher duty cycle.

### Inductor Selection and Maximum Output Current

The LT8610AC/LT8610AC-1 is designed to minimize solution size by allowing the inductor to be chosen based on the output load requirements of the application. During overload or short-circuit conditions the LT8610AC/LT8610AC-1 safely tolerates operation with a saturated inductor through the use of a high speed peak-current mode architecture.

A good first choice for the inductor value is:

$$L = \frac{V_{OUT} + V_{SW(BOT)}}{f_{SW}} \quad (6)$$

where f<sub>SW</sub> is the switching frequency in MHz, V<sub>OUT</sub> is the output voltage, V<sub>SW(BOT)</sub> is the bottom switch drop (~0.21V) and L is the inductor value in μH.

## APPLICATIONS INFORMATION

To avoid overheating and poor efficiency, an inductor must be chosen with an RMS current rating that is greater than the maximum expected output load of the application. In addition, the saturation current (typically labeled  $I_{SAT}$ ) rating of the inductor must be higher than the load current plus 1/2 of inductor ripple current:

$$I_{L(PEAK)} = I_{LOAD(MAX)} + \frac{1}{2} \Delta I_L \quad (7)$$

where  $\Delta I_L$  is the inductor ripple current as calculated in Equation 9 and  $I_{LOAD(MAX)}$  is the maximum output load for a given application.

As a quick example, an application requiring 1A output should use an inductor with an RMS rating of greater than 1A and an  $I_{SAT}$  of greater than 1.3A. During long duration overload or short-circuit conditions, the inductor RMS rating requirement is greater to avoid overheating of the inductor. To keep the efficiency high, the series resistance (DCR) should be less than 0.04 $\Omega$ , and the core material should be intended for high frequency applications.

The LT8610AC/LT8610AC-1 limits the peak switch current in order to protect the switches and the system from overload faults. The top switch current limit ( $I_{LIM}$ ) is at least 6A at low duty cycles and decreases linearly to 5A at DC = 0.8. The inductor value must then be sufficient to supply the desired maximum output current ( $I_{OUT(MAX)}$ ), which is a function of the switch current limit ( $I_{LIM}$ ) and the ripple current.

$$I_{OUT(MAX)} = I_{LIM} - \frac{\Delta I_L}{2} \quad (8)$$

The peak-to-peak ripple current in the inductor can be calculated as follows:

$$\Delta I_L = \frac{V_{OUT}}{L \cdot f_{SW}} \cdot \left( 1 - \frac{V_{OUT}}{V_{IN(MAX)}} \right) \quad (9)$$

where  $f_{SW}$  is the switching frequency of the LT8610AC/LT8610AC-1, and  $L$  is the value of the inductor. Therefore, the maximum output current that the LT8610AC/LT8610AC-1 will deliver depends on the switch current limit, the inductor value, and the input and output voltages.

The inductor value may have to be increased if the inductor ripple current does not allow sufficient maximum output current ( $I_{OUT(MAX)}$ ) given the switching frequency, and maximum input voltage used in the desired application.

The optimum inductor for a given application may differ from the one indicated by this design guide. A larger value inductor provides a higher maximum load current and reduces the output voltage ripple. For applications requiring smaller load currents, the value of the inductor may be lower and the LT8610AC/LT8610AC-1 may operate with higher ripple current. This allows use of a physically smaller inductor, or one with a lower DCR resulting in higher efficiency. Be aware that low inductance may result in discontinuous mode operation, which further reduces maximum load current.

Inductor value has a very strong effect on Burst Mode efficiency. Larger value inductors allow more charge to be transferred to the output per pulse, which increases both efficiency and output voltage ripple. If higher efficiency is needed in a Burst Mode application, increasing inductor value can be a quick solution.

For more information about maximum output current and discontinuous operation, see Linear Technology's Application Note 44.

Finally, for duty cycles greater than 50% ( $V_{OUT}/V_{IN} > 0.5$ ), a minimum inductance is required to avoid sub-harmonic oscillation. See Application Note 19.

### Input Capacitor

Bypass the input of the LT8610AC/LT8610AC-1 circuit with a ceramic capacitor of X7R or X5R type placed as close as possible to the  $V_{IN}$  and PGND pins. Y5V types have poor performance over temperature and applied voltage, and should not be used. A 4.7 $\mu$ F to 10 $\mu$ F ceramic capacitor is adequate to bypass the LT8610AC/LT8610AC-1 and will easily handle the ripple current. Note that larger input capacitance is required when a lower switching frequency is used. If the input power source has high impedance, or there is significant inductance due to long wires or cables, additional bulk capacitance may be necessary. This can be provided with a low performance electrolytic capacitor.

## APPLICATIONS INFORMATION

Step-down regulators draw current from the input supply in pulses with very fast rise and fall times. The input capacitor is required to reduce the resulting voltage ripple at the LT8610AC/LT8610AC-1 and to force this very high frequency switching current into a tight local loop, minimizing EMI. A 4.7 $\mu$ F capacitor is capable of this task, but only if it is placed close to the LT8610AC/LT8610AC-1 (see the PCB Layout section). A second precaution regarding the ceramic input capacitor concerns the maximum input voltage rating of the LT8610AC/LT8610AC-1. A ceramic input capacitor combined with trace or cable inductance forms a high quality (under damped) tank circuit. If the LT8610AC/LT8610AC-1 circuit is plugged into a live supply, the input voltage can ring to twice its nominal value, possibly exceeding the LT8610AC/LT8610AC-1's voltage rating. This situation is easily avoided (see Linear Technology Application Note 88).

### Output Capacitor and Output Ripple

The output capacitor has two essential functions. Along with the inductor, it filters the square wave generated by the LT8610AC/LT8610AC-1 to produce the DC output. In this role it determines the output ripple, thus low impedance at the switching frequency is important. The second function is to store energy in order to satisfy transient loads and stabilize the LT8610AC/LT8610AC-1's control loop. Ceramic capacitors have very low equivalent series resistance (ESR) and provide the best ripple performance. For good starting values, see the Typical Applications section.

Use X5R or X7R types. This choice will provide low output ripple and good transient response. Transient performance can be improved with a higher value output capacitor and the addition of a feedforward capacitor placed between  $V_{OUT}$  and FB. Increasing the output capacitance will also decrease the output voltage ripple. A lower value of output capacitor can be used to save space and cost but transient performance will suffer and may cause loop instability. See the Typical Applications in this data sheet for suggested capacitor values.

When choosing a capacitor, special attention should be given to the data sheet to calculate the effective capacitance under the relevant operating conditions of voltage bias and temperature. A physically larger capacitor or one with a higher voltage rating may be required.

### Ceramic Capacitors

Ceramic capacitors are small, robust and have very low ESR. However, ceramic capacitors can cause problems when used with the LT8610AC/LT8610AC-1 due to their piezoelectric nature. When in Burst Mode operation, the LT8610AC/LT8610AC-1's switching frequency depends on the load current, and at very light loads the LT8610AC/LT8610AC-1 can excite the ceramic capacitor at audio frequencies, generating audible noise. Since the LT8610AC/LT8610AC-1 operates at a lower current limit during Burst Mode operation, the noise is typically very quiet to a casual ear. If this is unacceptable, use a high performance tantalum or electrolytic capacitor at the output. Low noise ceramic capacitors are also available.

A final precaution regarding ceramic capacitors concerns the maximum input voltage rating of the LT8610AC/LT8610AC-1. As previously mentioned, a ceramic input capacitor combined with trace or cable inductance forms a high quality (underdamped) tank circuit. If the LT8610AC/LT8610AC-1 circuit is plugged into a live supply, the input voltage can ring to twice its nominal value, possibly exceeding the LT8610AC/LT8610AC-1's rating. This situation is easily avoided (see Linear Technology Application Note 88).

### Enable Pin

The LT8610AC/LT8610AC-1 is in shutdown when the EN pin is low and active when the pin is high. The rising threshold of the EN comparator is 1.015V, with 45mV of hysteresis. The EN pin can be tied to  $V_{IN}$  if the shutdown feature is not used, or tied to a logic level if shutdown control is required.

Adding a resistor divider from  $V_{IN}$  to EN programs the LT8610AC/LT8610AC-1 to regulate the output only when  $V_{IN}$  is above a desired voltage (see the Block Diagram). Typically, this threshold,  $V_{IN(EN)}$ , is used in situations where the input supply is current limited, or has a relatively high source resistance. A switching regulator draws constant power from the source, so source current increases as source voltage drops. This looks like a negative resistance load to the source and can cause the source to current limit or latch low under low source voltage conditions. The  $V_{IN(EN)}$  threshold prevents the regulator from operating at source voltages where the problems might occur. This

## APPLICATIONS INFORMATION

threshold can be adjusted by setting the values R3 and R4 such that they satisfy the following equation:

$$V_{IN(EN)} = \left( \frac{R3}{R4} + 1 \right) \cdot 1.015V \quad (10)$$

where the LT8610AC/LT8610AC-1 will remain off until  $V_{IN}$  is above  $V_{IN(EN)}$ . Due to the comparator's hysteresis, switching will not stop until the input falls slightly below  $V_{IN(EN)}$ .

When operating in Burst Mode operation for light load currents, the current through the  $V_{IN(EN)}$  resistor network can easily be greater than the supply current consumed by the LT8610AC/LT8610AC-1. Therefore, the  $V_{IN(EN)}$  resistors should be large to minimize their effect on efficiency at low loads.

### INTV<sub>CC</sub> Regulator

An internal low dropout (LDO) regulator produces the 3.4V supply from  $V_{IN}$  that powers the drivers and the internal bias circuitry. The INTV<sub>CC</sub> can supply enough current for the LT8610AC/LT8610AC-1's circuitry and must be bypassed to ground with a minimum of 1μF ceramic capacitor. Good bypassing is necessary to supply the high transient currents required by the power MOSFET gate drivers. To improve efficiency the internal LDO can also draw current from the BIAS pin when the BIAS pin is at 3.1V or higher. Typically the BIAS pin can be tied to the output of the LT8610AC/LT8610AC-1, or can be tied to an external supply of 3.3V or above. If BIAS is connected to a supply other than  $V_{OUT}$ , be sure to bypass with a local ceramic capacitor. If the BIAS pin is below 3.0V, the internal LDO will consume current from  $V_{IN}$ . Applications with high input voltage and high switching frequency where the internal LDO pulls current from  $V_{IN}$  will increase die temperature because of the higher power dissipation across the LDO. Do not connect an external load to the INTV<sub>CC</sub> pin.

### Output Voltage Tracking and Soft-Start

The LT8610AC/LT8610AC-1 allows the user to program its output voltage ramp rate by means of the TR/SS pin. An internal 2.2μA pulls up the TR/SS pin to INTV<sub>CC</sub>. Putting an external capacitor on TR/SS enables soft starting the output to prevent current surge on the input supply. During the soft-start ramp the output voltage will proportionally track the TR/SS

pin voltage. For output tracking applications, TR/SS can be externally driven by another voltage source. From 0V to 0.8V, the TR/SS voltage will override the internal 0.8V reference input to the error amplifier, thus regulating the FB pin voltage to that of TR/SS pin. When TR/SS is above 0.8V, tracking is disabled and the feedback voltage will regulate to the internal reference voltage.

The LT8610AC-1 has an additional TR/SS pin feature not included in the LT8610AC. During dropout or brownout, when the FB pin is below the regulated value, the LT8610AC-1 regulates the TR/SS pin to the same voltage as the FB pin. When the dropout or brownout condition goes away, the LT8610AC-1 output voltage will slowly ramp-up with the soft-start voltage preventing output voltage overshoot. Scope shots of the LT8610AC-1 recovering from dropout and short-circuit are show in Fig. 3.

In the LT8610AC, the TR/SS pin may be left floating if the function is not needed. In the LT8610AC-1, the TR/SS pin must have at least 100pF of external capacitance.

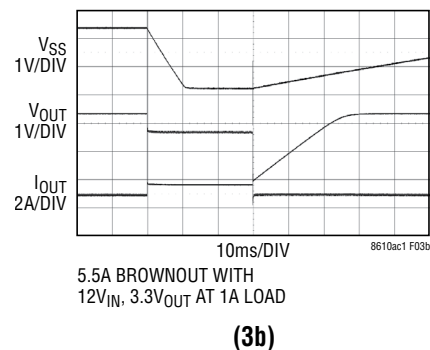
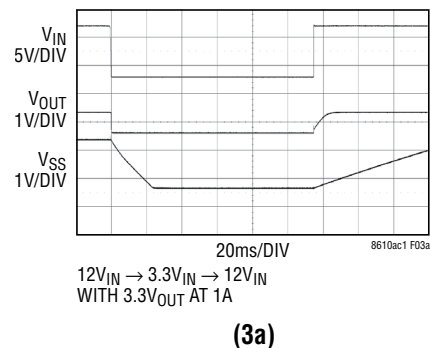

Figure 3. LT8610AC-1 Soft Starting to Eliminate Output Voltage Overshoot When Exiting Dropout (3a) and Brownout (3b)

## APPLICATIONS INFORMATION

An active pull-down circuit is connected to the TR/SS pin which will discharge the external soft-start capacitor in the case of fault conditions and restart the ramp when the faults are cleared. Fault conditions that clear the soft-start capacitor are the EN/UV pin transitioning low,  $V_{IN}$  voltage falling too low, or thermal shutdown.

### Output Power Good

When the LT8610AC/LT8610AC-1's output voltage is within the  $\pm 8\%$  window of the regulation point, which is a  $V_{FB}$  voltage in the range of 0.736V to 0.864V (typical), the output voltage is considered good and the open-drain PG pin goes high impedance and is typically pulled high with an external resistor. Otherwise, the internal pull-down device will pull the PG pin low. To prevent glitching both the upper and lower thresholds include 0.4% of hysteresis.

The PG pin is also actively pulled low during several fault conditions: EN/UV pin is below 1.015V,  $INTV_{CC}$  has fallen too low,  $V_{IN}$  is too low, or thermal shutdown.

### Synchronization

To select low ripple Burst Mode operation, tie the SYNC pin below 0.4V (this can be ground or a logic low output). To synchronize the LT8610AC/LT8610AC-1 oscillator to an external frequency connect a square wave (with 20% to 80% duty cycle) to the SYNC pin. The square wave amplitude should have valleys that are below 0.4V and peaks above 2.4V (up to 6V).

The LT8610AC/LT8610AC-1 will not enter Burst Mode operation at low output loads while synchronized to an external clock, but instead will pulse skip to maintain regulation. The LT8610AC may be synchronized over a 200kHz to 2.2MHz range, while the LT8610AC-1 can only be synchronized over a 1.5MHz to 2.2MHz range. The  $R_T$  resistor should be chosen to set the LT8610AC/LT8610AC-1 switching frequency equal to or below the lowest synchronization input. For example, if the synchronization signal will be 500kHz and higher, the  $R_T$  should be selected for 500kHz. The slope compensation is set by the  $R_T$  value, while the minimum slope compensation required to avoid subharmonic oscillations is established by the inductor size, input voltage, and output voltage. Since the synchronization frequency will not change the

slopes of the inductor current waveform, if the inductor is large enough to avoid subharmonic oscillations at the frequency set by  $R_T$ , then the slope compensation will be sufficient for all synchronization frequencies.

For some applications it is desirable for the LT8610AC/LT8610AC-1 to operate in pulse-skipping mode, offering two major differences from Burst Mode operation. First is the clock stays awake at all times and all switching cycles are aligned to the clock. Second is that full switching frequency is reached at lower output load than in Burst Mode operation. These two differences come at the expense of increased quiescent current. To enable pulse-skipping mode, the SYNC pin is tied high either to a logic output or to the  $INTV_{CC}$  pin.

The LT8610AC/LT8610AC-1 does not operate in forced continuous mode regardless of SYNC signal. Never leave the SYNC pin floating.

### Shorted and Reversed Input Protection

The LT8610AC/LT8610AC-1 will tolerate a shorted output. Several features are used for protection during output short-circuit and brownout conditions. The first is the switching frequency will be folded back while the output is lower than the set point to maintain inductor current control. Second, the bottom switch current is monitored such that if inductor current is beyond safe levels switching of the top switch will be delayed until such time as the inductor current falls to safe levels.

The LT8610AC-1 has a feature where the TR/SS pin voltage will be regulated to the same voltage as the FB pin. This means the part will soft-start out of an output short-circuit or brownout condition preventing output voltage overshoot.

Frequency foldback behavior depends on the state of the SYNC pin: If the SYNC pin is low the switching frequency will slow while the output voltage is lower than the programmed level. If the SYNC pin is connected to a clock source or tied high, the LT8610AC/LT8610AC-1 will stay at the programmed frequency without foldback and only slow switching if the inductor current exceeds safe levels.

There is another situation to consider in systems where the output will be held high when the input to the LT8610AC/LT8610AC-1 is absent. This may occur in battery charg-

## APPLICATIONS INFORMATION

ing applications or in battery-backup systems where a battery or some other supply is diode ORed with the LT8610AC/LT8610AC-1's output. If the  $V_{IN}$  pin is allowed to float and the EN pin is held high (either by a logic signal or because it is tied to  $V_{IN}$ ), then the LT8610AC/LT8610AC-1's internal circuitry will pull its quiescent current through its SW pin. This is acceptable if the system can tolerate several  $\mu\text{A}$  in this state. If the EN pin is grounded the SW pin current will drop to near  $1\mu\text{A}$ . However, if the  $V_{IN}$  pin is grounded while the output is held high, regardless of EN, parasitic body diodes inside the LT8610AC/LT8610AC-1 can pull current from the output through the SW pin and the  $V_{IN}$  pin. Figure 4 shows a connection of the  $V_{IN}$  and EN/UV pins that will allow the LT8610AC/LT8610AC-1 to run only when the input voltage is present and that protects against a shorted or reversed input.

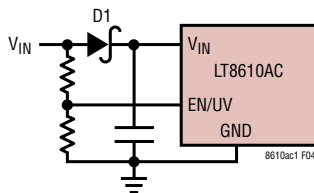

Figure 4. Reverse  $V_{IN}$  Protection

## PCB Layout

For proper operation and minimum EMI, care must be taken during printed circuit board layout. Figure 5 shows the recommended component placement with trace, ground plane and via locations. Note that large, switched currents flow in the LT8610AC/LT8610AC-1's  $V_{IN}$  pins, GND pins, and the input capacitor (C1). The loop formed by the input capacitor should be as small as possible by placing the capacitor adjacent to the  $V_{IN}$  and GND pins. When using a physically large input capacitor the resulting loop may become too large in which case using a small case/value capacitor placed close to the  $V_{IN}$  and GND pins plus a larger capacitor further away is preferred. These components, along with the inductor and output capacitor, should be placed on the same side of the circuit board, and their connections should be made on that layer. Place a local, unbroken ground plane under the application circuit on the layer closest to the surface layer. The SW and BOOST nodes should be as small as possible. Finally, keep the FB

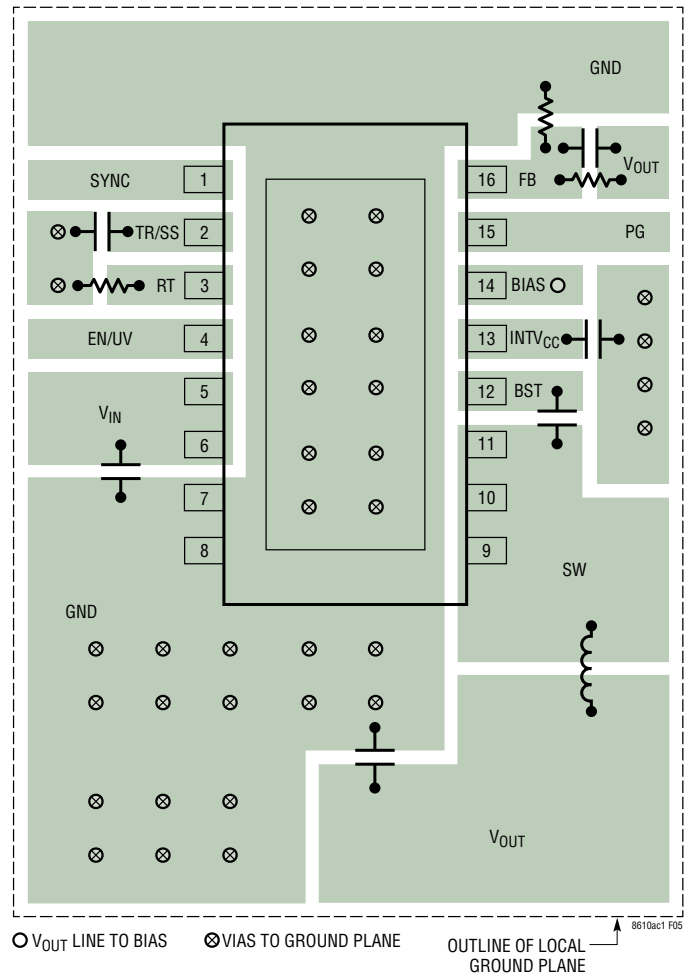

Figure 5. Recommended PCB Layout for the LT8610AC

and RT nodes small so that the ground traces will shield them from the SW and BOOST nodes. The exposed pad on the bottom of the package must be soldered to ground so that the pad is connected to ground electrically and also acts as a heat sink thermally. To keep thermal resistance low, extend the ground plane as much as possible, and add thermal vias under and near the LT8610AC/LT8610AC-1 to additional ground planes within the circuit board and on the bottom side.

Unlike the LT8610, the LT8610AC/LT8610AC-1 has pin 7 as an NC (no connect) pin. This pin can be soldered to GND to have an LT8610 compatible PCB layout. Alternatively, pin 7 can be left unconnected to help meet PCB clearance and creepage requirements between the  $V_{IN}$  and GND traces.

# LT8610AC/LT8610AC-1

## APPLICATIONS INFORMATION

### High Temperature Considerations

For higher ambient temperatures, care should be taken in the layout of the PCB to ensure good heat sinking of the LT8610AC/LT8610AC-1. The exposed pad on the bottom of the package must be soldered to a ground plane. This ground should be tied to large copper layers below with thermal vias; these layers will spread heat dissipated by the LT8610AC/LT8610AC-1. Placing additional vias can reduce thermal resistance further. The maximum load current should be derated as the ambient temperature approaches the maximum junction rating. Power dissipation within the LT8610AC/LT8610AC-1 can be estimated by calculating the total power loss from an efficiency measurement and subtracting the inductor loss. The die temperature is calculated by multiplying the LT8610AC/LT8610AC-1 power dissipation by the thermal resistance from junction to ambient. The LT8610AC/LT8610AC-1 will stop switching and indicate a fault condition if safe junction temperature is exceeded.

Temperature rise of the LT8610AC/LT8610AC-1 is worst when operating at high load, high  $V_{IN}$ , and high switching

frequency. If the case temperature is too high for a given application, then either  $V_{IN}$ , switching frequency, or load current can be decreased to reduce the temperature to an acceptable level. Figure 6 shows an example of how case temperature can be managed by reducing  $V_{IN}$ , switching frequency, or load.

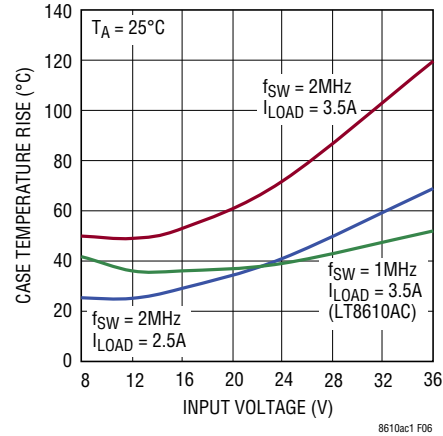
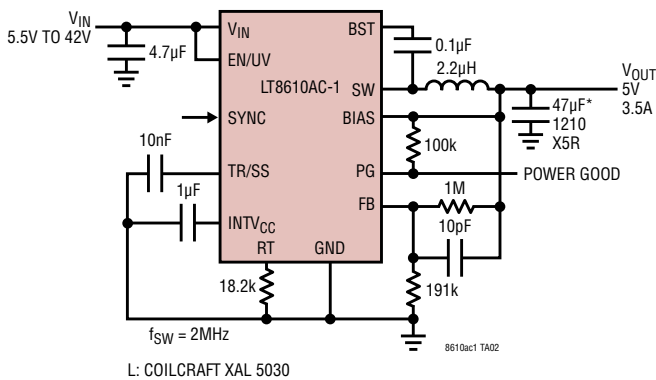

Figure 6. LT8610AC Case Temperature Rise

## TYPICAL APPLICATIONS

### 5V 2MHz Step-Down Converter



### 12V Step-Down Converter

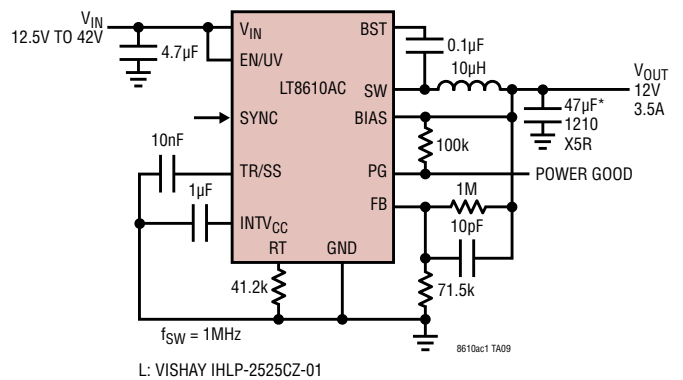

\*Consider doubling output capacitance if application requires low output voltage ripple in Burst Mode operation.

TYPICAL APPLICATIONS

5V Step-Down Converter

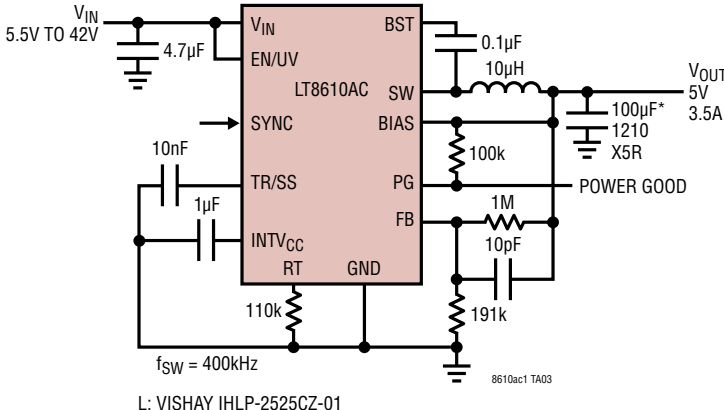

1.8V 2MHz Step-Down Converter

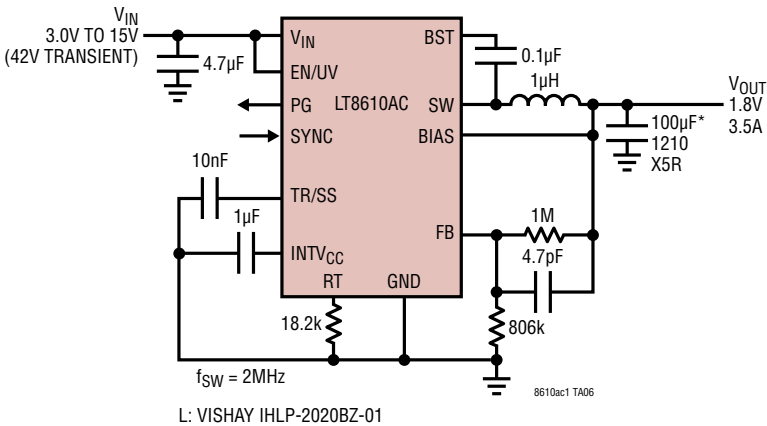

\*Consider doubling output capacitance if application requires low output voltage ripple in Burst Mode operation.

## TYPICAL APPLICATIONS

### 3.3V 2MHz Step-Down Converter

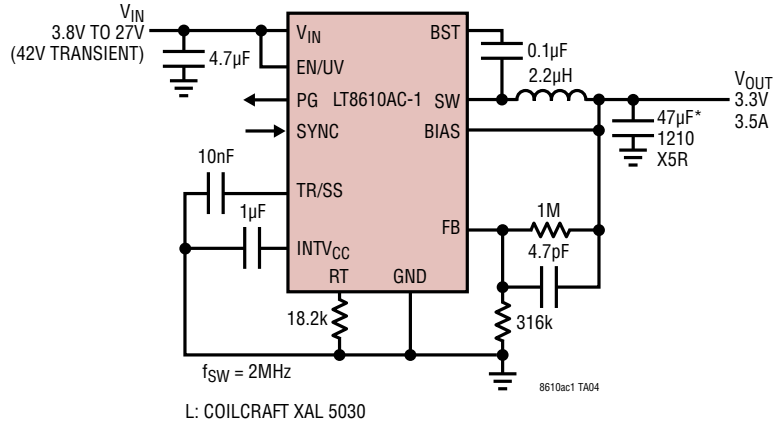

### 1.8V Step-Down Converter

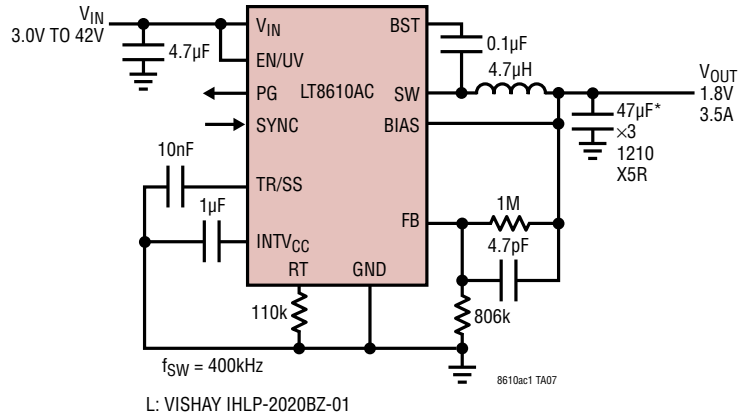

\*Consider doubling output capacitance if application requires low output voltage ripple in Burst Mode operation.

TYPICAL APPLICATIONS

3.3V Step-Down Converter

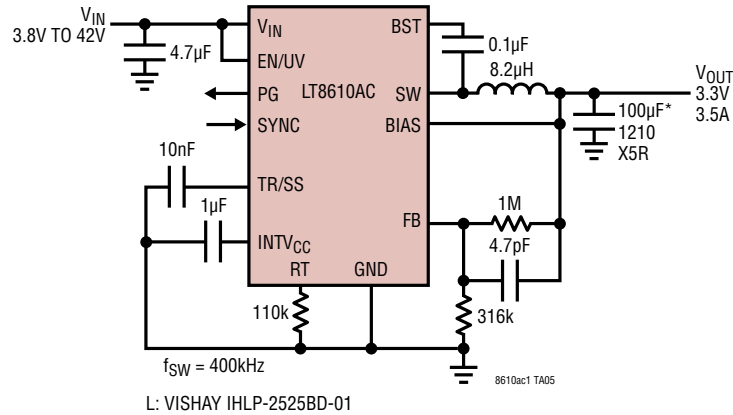

Ultralow EMI 5V 2.5A Step-Down Converter

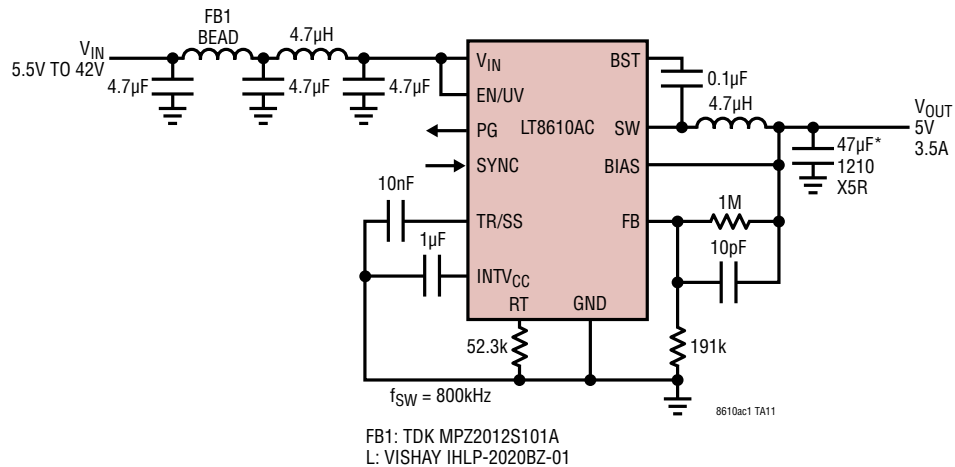

\*Consider doubling output capacitance if application requires low output voltage ripple in Burst Mode operation.

# LT8610AC/LT8610AC-1

## PACKAGE DESCRIPTION

Please refer to <http://www.linear.com/designtools/packaging/> for the most recent package drawings.

### MSE Package 16-Lead Plastic MSOP, Exposed Die Pad (Reference LTC DWG # 05-08-1667 Rev F)

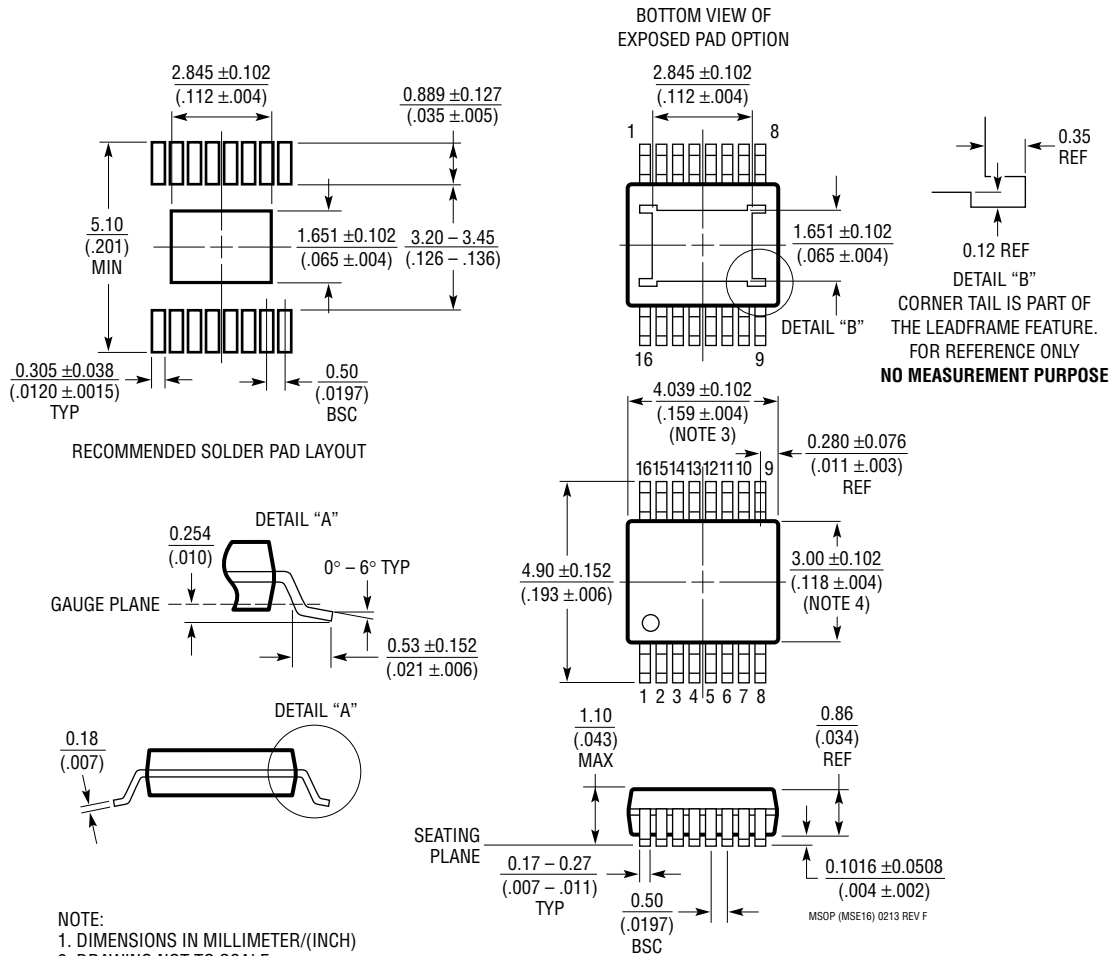

**NOTE:**

1. DIMENSIONS IN MILLIMETER/(INCH)
2. DRAWING NOT TO SCALE
3. DIMENSION DOES NOT INCLUDE MOLD FLASH, PROTRUSIONS OR GATE BURRS.  
MOLD FLASH, PROTRUSIONS OR GATE BURRS SHALL NOT EXCEED 0.152mm (.006") PER SIDE
4. DIMENSION DOES NOT INCLUDE INTERLEAD FLASH OR PROTRUSIONS.  
INTERLEAD FLASH OR PROTRUSIONS SHALL NOT EXCEED 0.152mm (.006") PER SIDE
5. LEAD COPLANARITY (BOTTOM OF LEADS AFTER FORMING) SHALL BE 0.102mm (.004") MAX
6. EXPOSED PAD DIMENSION DOES INCLUDE MOLD FLASH. MOLD FLASH ON E-PAD SHALL NOT EXCEED 0.254mm (.010") PER SIDE.

## REVISION HISTORY

REV	DATE	DESCRIPTION	PAGE NUMBER
A	05/15	Added the LT8610AC-1 version	all
		Added the LT8610AC-1 version and Description	1
		Added the LT8610AC-1 version to Order Information	2
		Added the LT8610AC-1 version to Electrical Characteristics and Note 2	3
		Added the LT8610AC-1 version to Pin Functions	7
		Added the LT8610AC-1 version to Operation section	11
		Added the LT8610AC-1 version to Applications section	12 to 22
		Added the LT8610AC-1 Typical Application	21, 22, 26

# LT8610AC/LT8610AC-1

## TYPICAL APPLICATION

### 3.3V and 1.8V with Ratio Tracking

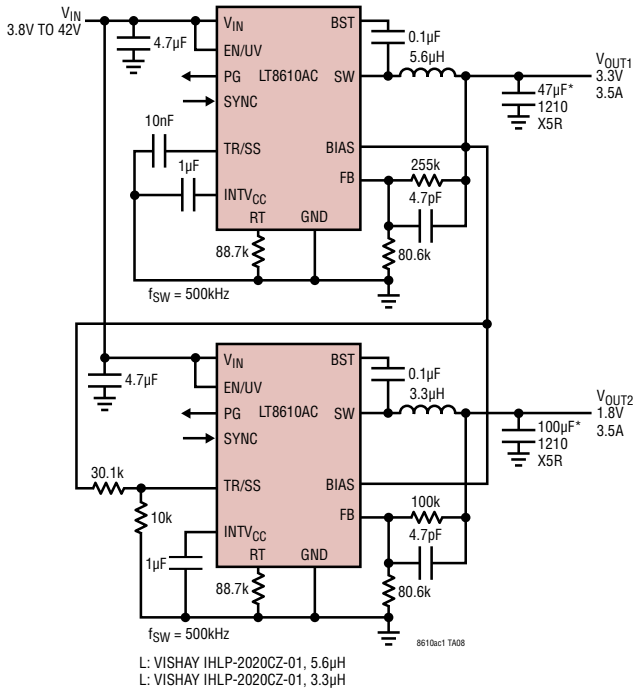

### Ultralow I<sub>Q</sub> 2.5V, 3.3V Step-Down with LDO

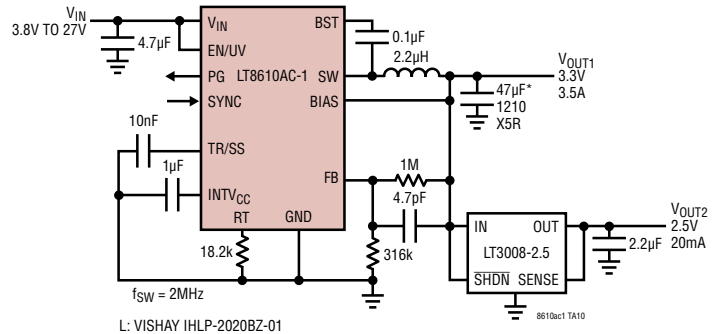

\*Consider doubling output capacitance if application requires low output voltage ripple in Burst Mode operation.



## RELATED PARTS

PART NUMBER	DESCRIPTION	COMMENTS
<a href="#">LT8610A/LT8610AB</a>	42V, 3.5A, 96% Efficiency, 2.2MHz Synchronous Micropower Step-Down DC/DC Converter with I <sub>Q</sub> = 2.5µA	V <sub>IN</sub> : 3.4V to 42V, V <sub>OUT(MIN)</sub> = 0.97V, I <sub>Q</sub> = 2.5µA, I <sub>SD</sub> < 1µA, MSOP-16E Package
<a href="#">LT8610</a>	42V, 2.5A, 96% Efficiency, 2.2MHz Synchronous Micropower Step-Down DC/DC Converter with I <sub>Q</sub> = 2.5µA	V <sub>IN</sub> : 3.4V to 42V, V <sub>OUT(MIN)</sub> = 0.97V, I <sub>Q</sub> = 2.5µA, I <sub>SD</sub> < 1µA, MSOP-16E Package
<a href="#">LT8611</a>	42V, 2.5A, 96% Efficiency, 2.2MHz Synchronous Micropower Step-Down DC/DC Converter with I <sub>Q</sub> = 2.5µA and Input/Output Current Limit/Monitor	V <sub>IN</sub> : 3.4V to 42V, V <sub>OUT(MIN)</sub> = 0.97V, I <sub>Q</sub> = 2.5µA, I <sub>SD</sub> < 1µA, 3mm × 5mm QFN-24 Package
<a href="#">LT8620</a>	65V, 2.5A, 96% Efficiency, 2.2MHz Synchronous Micropower Step-Down DC/DC Converter with I <sub>Q</sub> = 2.5µA	V <sub>IN</sub> : 3.4V to 65V, V <sub>OUT(MIN)</sub> = 0.97V, I <sub>Q</sub> = 2.5µA, I <sub>SD</sub> < 1µA, MSOP-16E and 3mm × 5mm QFN-24 Packages
<a href="#">LT8614</a>	42V, 4A, 96% Efficiency, 2.2MHz Synchronous Micropower Step-Down DC/DC Converter with I <sub>Q</sub> = 2.5µA	V <sub>IN</sub> : 3.4V to 42V, V <sub>OUT(MIN)</sub> = 0.97V, I <sub>Q</sub> = 2.5µA, I <sub>SD</sub> < 1µA, 3mm × 4mm QFN Package
<a href="#">LT8612</a>	42V, 6A, 96% Efficiency, 2.2MHz Synchronous Micropower Step-Down DC/DC Converter with I <sub>Q</sub> = 3µA	V <sub>IN</sub> : 3.4V to 42V, V <sub>OUT(MIN)</sub> = 0.97V, I <sub>Q</sub> = 3µA, I <sub>SD</sub> < 1µA, 3mm × 6mm QFN Package
<a href="#">LT3975</a>	4.3V, 2.5A, 2.2MHz Micropower Step-Down DC/DC Converter with I <sub>Q</sub> = 2.7µA	V <sub>IN</sub> : 4.3V to 42V, V <sub>OUT(MIN)</sub> = 1.2V, I <sub>Q</sub> = 2.7µA, I <sub>SD</sub> < 1µA, MSOP-16E Package
<a href="#">LT3976</a>	40V, 5A, 2.2MHz Micropower Step-Down DC/DC Converter with I <sub>Q</sub> = 3.3µA	V <sub>IN</sub> : 4.3V to 40V, V <sub>OUT(MIN)</sub> = 1.2V, I <sub>Q</sub> = 3.3µA, I <sub>SD</sub> < 1µA, MSOP-16E and 3mm × 5mm QFN-24 Packages

8610acfa

## Looking for pricing, stock, or lifecycle information?

Click below to explore more details on WIN SOURCE:

-  [View LT8610ACIMSE-1#TRPBF on WIN SOURCE](#)
-  [Linear Technology](#) Information

## Optimize Your Supply Chain with WIN SOURCE Solutions

-  Global Sourcing Solution
-  Obsolete Management
-  Cost Control Management
-  Shortage Management
-  Alternative Solution
-  Excess Inventory Management