



THE DATASHEET OF OPA362AIDCKR





3V VIDEO AMPLIFIER with Internal Gain and Filter in SC70

Check for Samples: [OPA362](#)

FEATURES

- **EXCELLENT VIDEO PERFORMANCE**
- **INTERNAL GAIN: 5.2V/V**
- **SUPPORTS TV-DETECTION**
- **COMPATIBLE WITH OMAP343x and DaVINCI™ PROCESSORS**
- **TWO-POLE RECONSTRUCTION FILTER**
- **INPUT RANGE INCLUDES GROUND**
 - DC-Coupled Input
- **INTEGRATED LEVEL SHIFTER**
 - DC-Coupled Output⁽¹⁾
 - No Output Capacitors Needed
- **RAIL-TO-RAIL OUTPUT**
- **LOW QUIESCENT CURRENT: 4.3mA**
- **SHUTDOWN CURRENT: 1.5µA**
- **SINGLE-SUPPLY: 2.5V to 3.3V**
- **SC70-6 PACKAGE: 2.0mm x 2.1mm**
- **RoHS COMPLIANT**

⁽¹⁾ Internal circuitry avoids output saturation, even with 0V sync tip level at the input video signal.

APPLICATIONS

- **CAMERA PHONES**

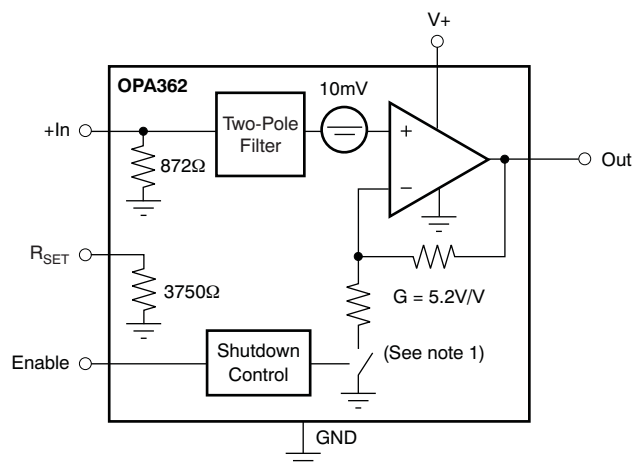

(1) Closed when enabled during normal operation; open when shut down.

DESCRIPTION

The OPA362 high-speed amplifier is optimized for 3V portable video applications. It is specifically designed to be compatible with the video encoders embedded in Texas Instruments' OMAP3430 and DaVinci processors or other application processors with 0.5V_{PP} video output. The input common-mode range includes GND, which allows a video-DAC (digital-to-analog converter) to be dc-coupled to the OPA362. The TV-detection feature simplifies the end-user interface significantly by facilitating the automatic start/stop of video transmission.

The output swings within 5mV of GND and 250mV to V+ with a standard back-terminated video load (150Ω). An internal level shift circuit prevents the output from saturating with 0V input, thus preventing sync-pulse clipping in common video circuits. Therefore, the OPA362 is ideally suited for dc-coupling to the video load.

The OPA362 has been optimized for space-sensitive applications by integrating internal gain setting resistors ($G = 5.2V/V$) and a two-pole video-DAC reconstruction filter.

In shutdown mode, quiescent current is reduced to less than 1.5µA, dramatically reducing power consumption and prolonging battery life.

The OPA362 is available in the tiny 2mm × 2.1mm SC70-6 package.

RELATED LOW-VOLTAGE VIDEO AMPS

FEATURES	PRODUCT
2.7V to 3.3V, 70MHz, 6mA IQ, 5µA Sleep, SC70	OPA358
2.7V to 3.3V, Filter, SAG, $G = 2$, 5µA Sleep, SC70	OPA360
2.7V to 5.5V, 200MHz, 300V/µs, 6µA Sleep, SOT23	OPA355
2.7V to 5.5V, 100MHz, 150V/µs, 6µA Sleep, SOT23	OPA357
3V Video Amplifier with Internal Gain and Filter, SC70	OPA361



Please be aware that an important notice concerning availability, standard warranty, and use in critical applications of Texas Instruments semiconductor products and disclaimers thereto appears at the end of this data sheet.

DaVINCI is a trademark of Texas Instruments.
All other trademarks are the property of their respective owners.



This integrated circuit can be damaged by ESD. Texas Instruments recommends that all integrated circuits be handled with appropriate precautions. Failure to observe proper handling and installation procedures can cause damage.

ESD damage can range from subtle performance degradation to complete device failure. Precision integrated circuits may be more susceptible to damage because very small parametric changes could cause the device not to meet its published specifications.

ABSOLUTE MAXIMUM RATINGS⁽¹⁾

Over operating free-air temperature range, unless otherwise noted.

		VALUE	UNIT
Supply Voltage, V+ to V–		+3.6	V
Signal Input Terminals	Voltage ⁽²⁾	– 0.5 to (V+) + 0.5	V
	Current ⁽²⁾	±10	mA
Output Short-Circuit through 75Ω to GND ⁽³⁾		Continuous	
Operating Temperature		–40 to +125	°C
Storage Temperature		–65 to +150	°C
Junction Temperature		+160	°C
ESD Ratings	Human Body Model (HBM)	5000	V
	Charged Device Model (CDM)	2000	V
	Machine Model (MM)	400	V

- (1) Stresses above these ratings may cause permanent damage. Exposure to absolute maximum conditions for extended periods may degrade device reliability. These are stress ratings only, and functional operation of the device at these or any other conditions beyond those specified is not supported.
- (2) Input terminals are diode-clamped to the power-supply rails. Input signals that can swing more than 0.5V beyond the supply rails should be current-limited to 10mA or less.
- (3) Short-circuit to ground.

PACKAGE INFORMATION⁽¹⁾

PRODUCT	PACKAGE-LEAD	PACKAGE DESIGNATOR	PACKAGE MARKING
OPA362	SC70-6	DCK	OEA

- (1) For the most current package and ordering information see the Package Option Addendum at the end of this document, or see the TI web site at www.ti.com.

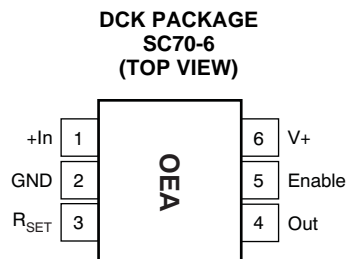

Note: The location of pin 1 on the OPA362 is determined by orienting the package marking as shown in the illustration.

ELECTRICAL CHARACTERISTICS: $V_S = +2.5V$ to $+3.3V$
Boldface limits apply over the temperature range, $T_A = -40^\circ C$ to $+125^\circ C$.

At $T_A = +25^\circ C$ and $R_L = 150\Omega$ connected to ground, unless otherwise noted.

PARAMETER	CONDITIONS	OPA362			UNIT
		MIN	TYP	MAX	
OFFSET LEVEL-SHIFT VOLTAGE					
Output Level-Shift Voltage ⁽¹⁾ V_{OLS}	$V_S = +2.8V, V_{IN} = GND$	-3	11	55	mV
Over Temperature vs Power Supply $PSRR$	$V_S = +2.5V$ to $+3.3V$		20 ± 80		mV $\mu V/V$
INPUT VOLTAGE RANGE					
Input Voltage Range ⁽²⁾ V_{CM}	$V_S = 2.5V$	GND		0.42	V
	$V_S = 2.8V$	GND		0.48	V
	$V_S = 3.3V$	GND		0.55	V
Input Resistance (+In) R_{IN}		776	872	968	Ω
R_{SET} Resistance R_{SET}		3337	3750	4163	Ω
Matching of R_{IN} and R_{SET}		2	0.5		%
VOLTAGE GAIN					
	$\Delta V_{OUT}/\Delta V_{IN}, V_S = +2.5V, V_{INMIN} = 0V, V_{INMAX} = 0.42V$	5.06	5.17	5.28	V/V
	$\Delta V_{OUT}/\Delta V_{IN}, V_S = +2.8V, V_{INMIN} = 0V, V_{INMAX} = 0.48V$	5.06	5.17	5.28	V/V
	$\Delta V_{OUT}/\Delta V_{IN}, V_S = +3.3V, V_{INMIN} = 0V, V_{INMAX} = 0.55V$	5.06	5.17	5.28	V/V
FREQUENCY RESPONSE					
Filter Response					
Cutoff Frequency f_{-3dB}			8.5		MHz
Normalized Gain:					
$f_{IN} = 4.5MHz$	$V_O = 2V_{PP}$		-1		dB
$f_{IN} = 27MHz$	$V_O = 2V_{PP}$		-18		dB
$f_{IN} = 54MHz$	$V_O = 2V_{PP}$		-25		dB
Differential Gain Error	$R_L = 150\Omega$		1.2		%
Differential Phase Error	$R_L = 150\Omega$		1.6		Degrees
Group Delay Variation	100kHz, 4.5MHz		26		ns
Signal-to-Noise Ratio SNR	100% White Signal		65		dB
OUTPUT					
Positive Voltage Output Swing from Rail	$V_S = +2.8V, V_{IN} = 0.7V, R_L = 150\Omega$ to GND		130	250	mV
Negative Voltage Output Swing from Rail	$V_S = +2.8V, V_{IN} = -0.05V, R_L = 150\Omega$ to GND		0.15	5	mV
Positive Voltage Output Swing from Rail	$V_S = +2.8V, V_{IN} = 0.7V, R_L = 75\Omega$ to GND		260		mV
Negative Voltage Output Swing from Rail	$V_S = +2.8V, V_{IN} = -0.05V, R_L = 75\Omega$ to GND		2		mV
Output Leakage	$V_S = +2.8V, Disabled, V_O = 2V$		0.1	100	nA
Output Current ⁽³⁾ I_O	$V_S = +2.8V$		± 80		mA
POWER SUPPLY					
Specified Voltage Range V_S		2.5		3.3	V
Quiescent Current I_Q	$V_S = +2.8V, Enabled, I_O = 0, V_{OUT} = 1.4V$		4.3	7.5	mA
Over Temperature	Specified Temperature Range			9	mA

(1) Output-referred.

(2) Limited by output swing and internal $G = 5.2V/V$.

(3) See typical characteristic graph, *Output Voltage Swing vs Output Current*.

ELECTRICAL CHARACTERISTICS: $V_S = +2.5V$ to $+3.3V$ (continued)

Boldface limits apply over the temperature range, $T_A = -40^\circ\text{C}$ to $+125^\circ\text{C}$.

At $T_A = +25^\circ\text{C}$ and $R_L = 150\Omega$ connected to ground, unless otherwise noted.

PARAMETER	CONDITIONS	OPA362			UNIT
		MIN	TYP	MAX	
ENABLE/SHUTDOWN FUNCTION					
Disabled (logic-LOW threshold)		0		0.5	V
Enabled (logic-HIGH threshold)		1.3		V_S	V
Enable Time			1.5		μs
Disable Time			50		ns
Shutdown Current	$V_S = +2.8V$, Disabled		1.5		μA
TEMPERATURE RANGE					
Specified/Operating Range		-40		+125	$^\circ\text{C}$
Thermal Resistance	θ_{JA}				
SC70			250		$^\circ\text{C/W}$

TYPICAL CHARACTERISTICS

At $T_A = +25^\circ\text{C}$, $V_S = 2.8\text{V}$, and $R_L = 150\Omega$, unless otherwise noted.

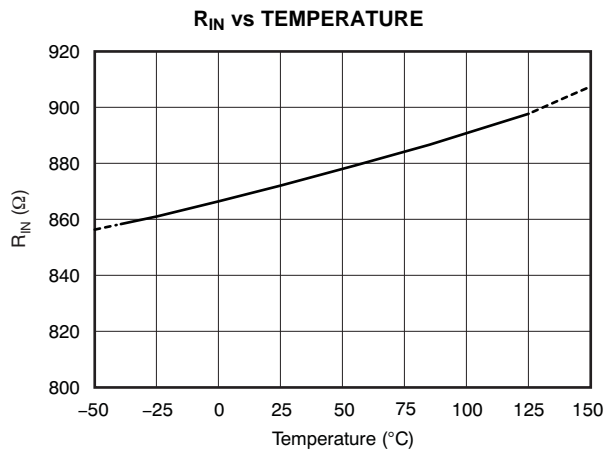

Figure 1.

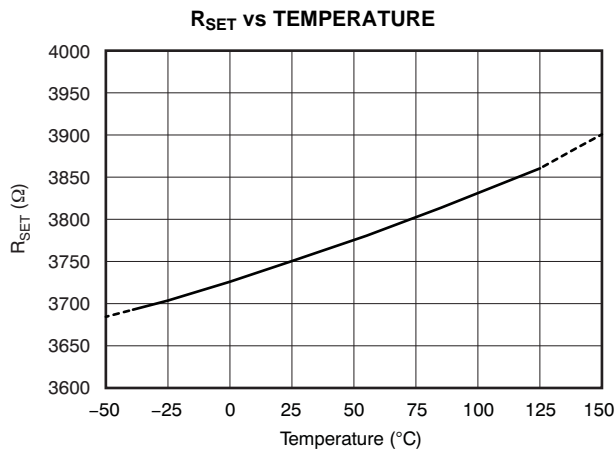

Figure 2.

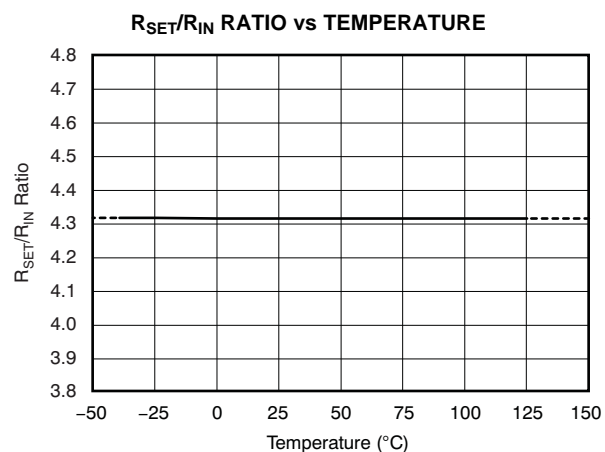

Figure 3.

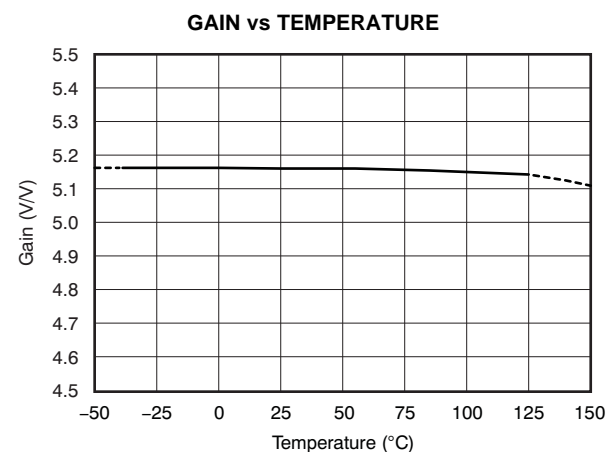

Figure 4.

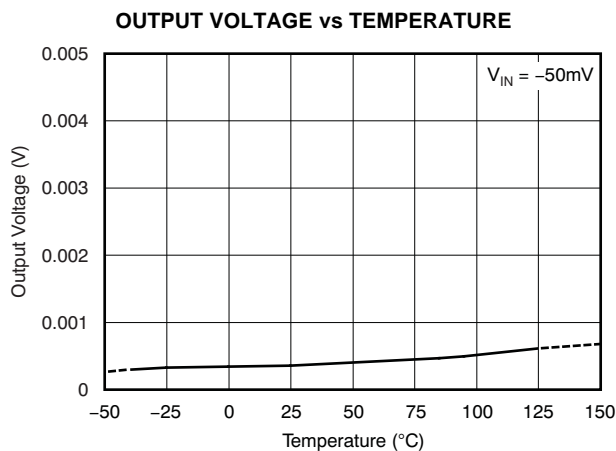

Figure 5.

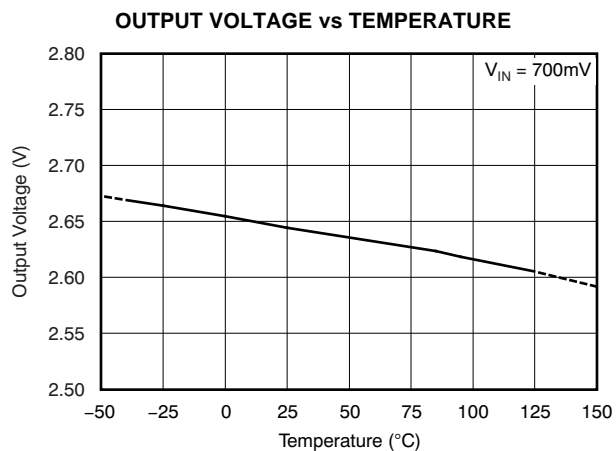

Figure 6.

TYPICAL CHARACTERISTICS (continued)

At $T_A = +25^\circ\text{C}$, $V_S = 2.8\text{V}$, and $R_L = 150\Omega$, unless otherwise noted.

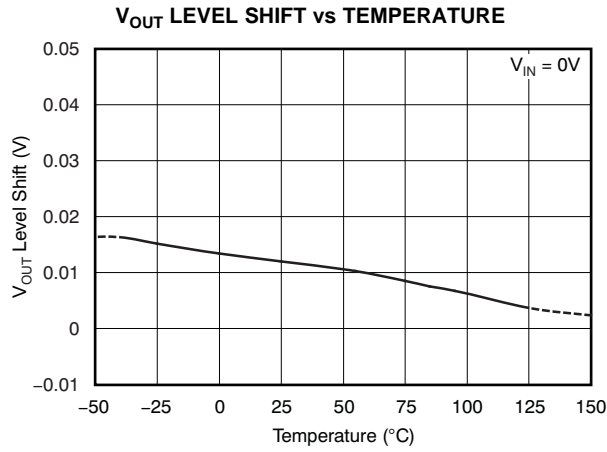

Figure 7.

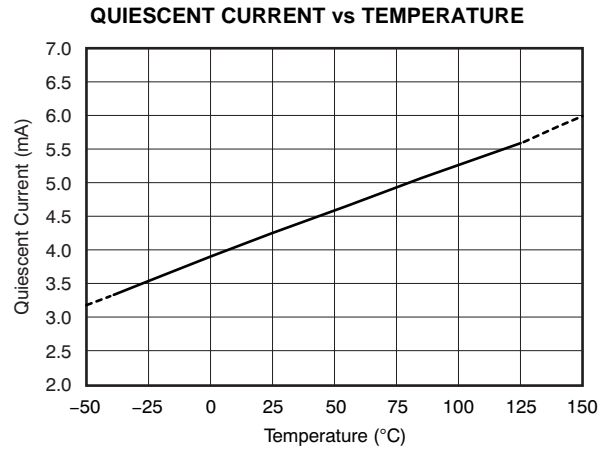

Figure 8.

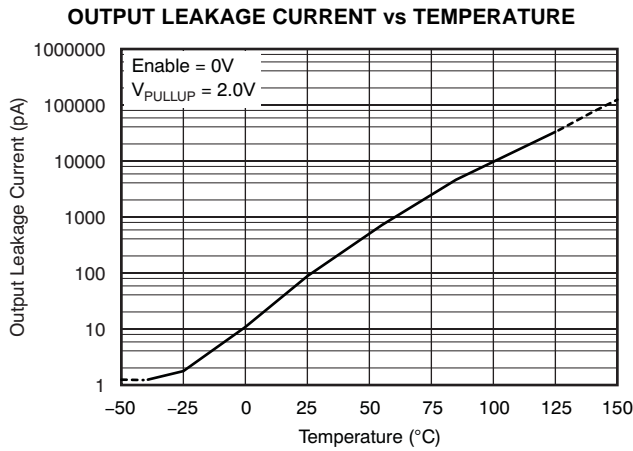

Figure 9.

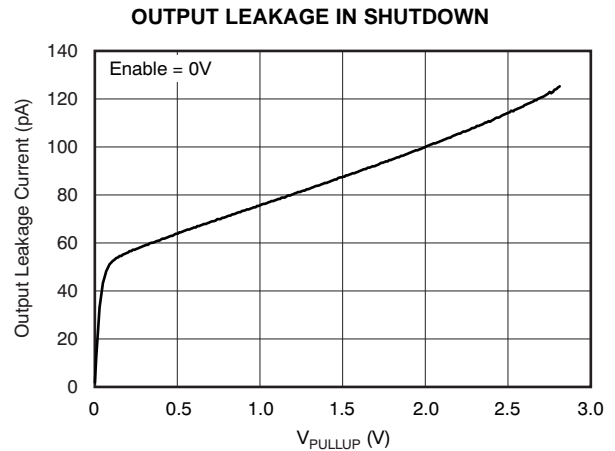

Figure 10.

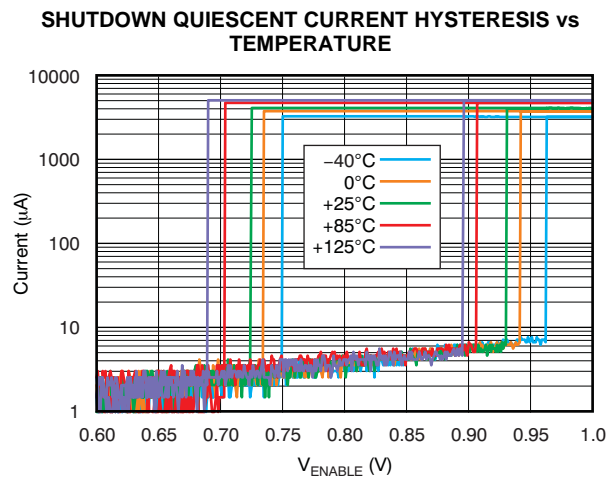

Figure 11.

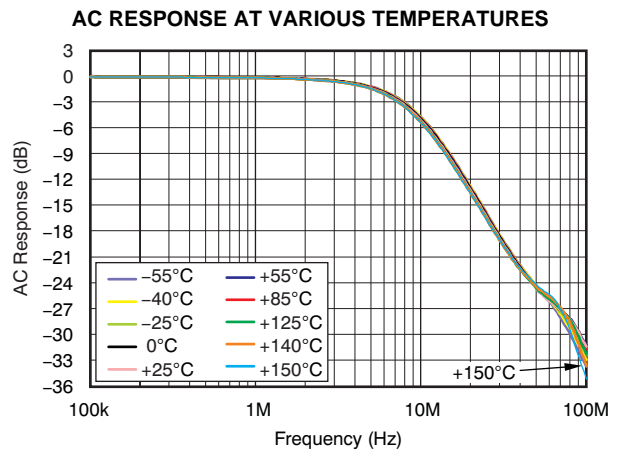

Figure 12.

TYPICAL CHARACTERISTICS (continued)

At $T_A = +25^\circ\text{C}$, $V_S = 2.8\text{V}$, and $R_L = 150\Omega$, unless otherwise noted.

TURN-ON TIME

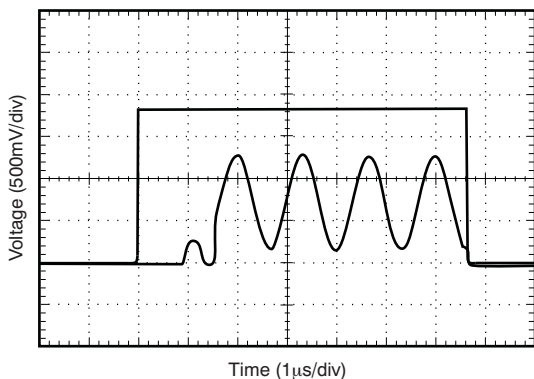

Figure 13.

TURN-OFF TIME

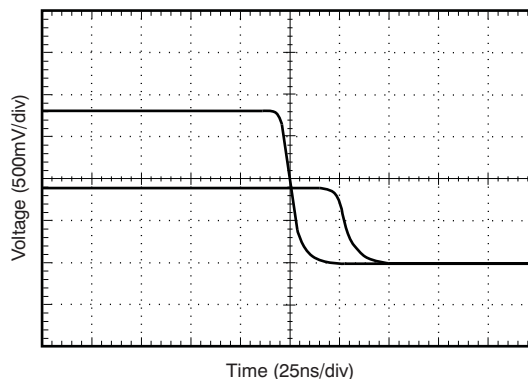

Figure 14.

OUTPUT VOLTAGE vs OUTPUT CURRENT

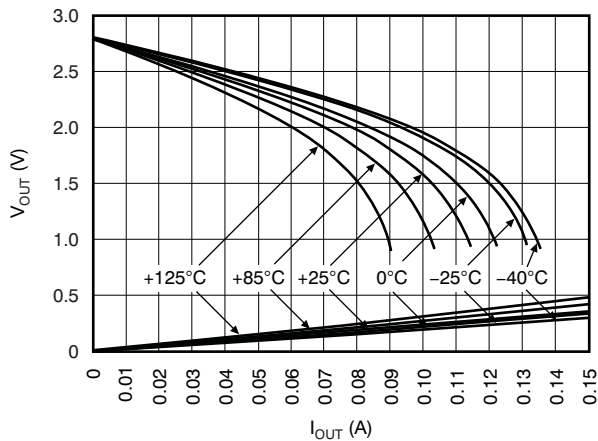

Figure 15.

GROUP DELAY vs FREQUENCY

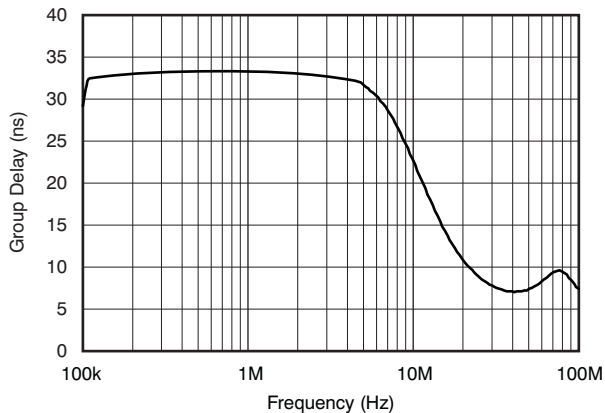

Figure 16.

DIFFERENTIAL GAIN AND PHASE

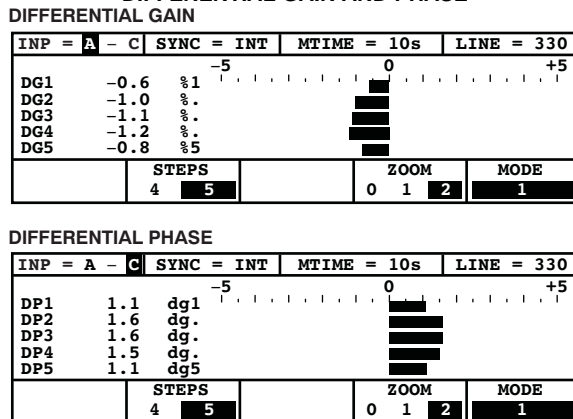

Figure 17.

APPLICATION INFORMATION

The OPA362 video amplifier has been optimized to fit seamlessly with Texas Instruments' OMAP343x multimedia processor. The following features have been integrated to provide excellent video performance:

- Internal gain setting resistors ($G = 5.2V/V$) reduce the number of external components needed in the video circuit.
- Integration of the 872Ω video encoder load resistor and 3750Ω R_{SET} resistor used by the OMAP343x helps minimize the number of external components and also ensures excellent ratio and temperature tracking. This feature helps to keep the overall gain accurate and stable over temperature.
- TV-detection support in connection with an OMAP343x multimedia processor. This feature helps to automate start/stop operation of the TV-out function and minimizes power

consumption.

- A two-pole filter is incorporated for DAC signal reconstruction.
- The OPA362 employs an internal level shift circuit that avoids sync pulse clipping and allows dc-coupled output.
- A shutdown feature reduces quiescent current to less than $1.5\mu A$ —crucial for portable applications.

Although the OPA362 is optimized for the OMAP343x processor, it is also well-suited to interface with any digital media processor that outputs a video signal on the order of $0.4V_{PP}$ to $0.5V_{PP}$.

Figure 18 shows a typical application drawing with the OMAP343x processor and the TWL92230 Energy Management Chip.

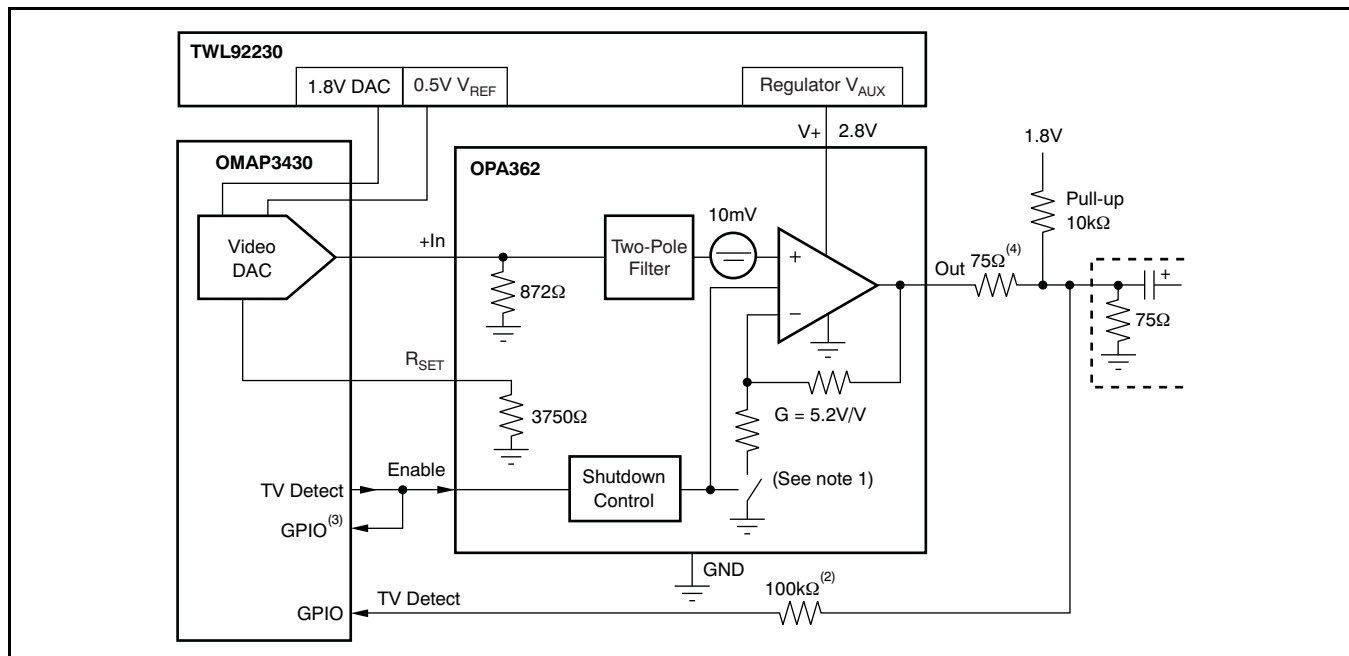

- (1) Closed when enabled during normal operation; open when shut down.
- (2) Protects GPIO against overvoltage conditions during active video transmission.
- (3) GPIO must be able to generate an interrupt.
- (4) External 75Ω resistor is necessary when driving 75Ω terminated loads.

Figure 18. Typical Application Using the OMAP343x and the TWL92230

Operating Voltage

The OPA362 is fully specified from 2.5V to 3.3V over a temperature range of -40°C to $+125^{\circ}\text{C}$. Parameters that vary significantly with operating voltages or temperature are shown in the [Typical Characteristics](#). Power-supply pins should be bypassed with 100nF ceramic capacitors.

Input Voltage

The input common-mode range of the OPA362 series extends from GND to 0.55V on a 3.3V supply. The input range is limited by the internal gain in conjunction with the maximum output swing capability and the power-supply voltage.

Input Overvoltage Protection

All OPA362 pins are static-protected with internal ESD protection diodes connected to the supplies. These diodes provide input overdrive protection if the current is externally limited to 10mA.

Enable/Shutdown

The OPA362 has a shutdown feature that disables the output and reduces the quiescent current to less than $1.5\mu\text{A}$. This feature is especially useful for portable video applications, where the device is infrequently connected to a television (TV) or other video device.

The Enable logic input voltage is referenced to the OPA362 GND pin. A logic level high applied to the

Enable pin enables the op amp. The logic levels are compatible with 1.8V CMOS logic levels. A valid logic high is defined as greater than 1.3V above GND. A valid logic low is defined as less than 0.5V above GND. If the Enable pin is not connected, internal pull-up circuitry enables the amplifier.

When disabling the OPA362, internal circuitry also disconnects the internal gain setting feedback. This feature supports the TV-detection function; see the [TV-Detect Function](#) section for more detailed information.

Internal Two-Pole Filter

The OPA362 filter is a Sallen-Key topology with an 8.5MHz cutoff frequency. [Figure 19](#) shows a detailed drawing of the filter components. This filter allows video signals to pass without any visible distortion, as shown in [Figure 20](#) through [Figure 23](#). The video encoder embedded in the OMAP343x processor typically samples at 54MHz. At this frequency, the attenuation is typically 23dB, which effectively attenuates the sampling aliases.

The internal 872Ω resistor on the input to GND converts the output current of the OMAP3430 internal video DAC into a voltage. It is also part of the Sallen-Key filter. Using an external resistor to adjust the input voltage range also changes the filter characteristics.

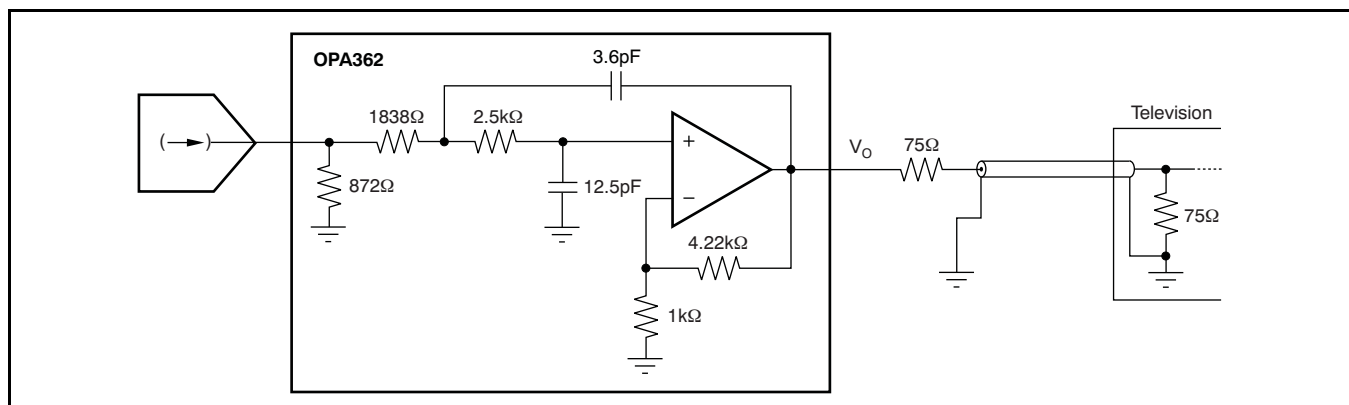

Figure 19. OPA362 Filter Structure

Video Performance

The color bar signal in [Figure 20](#) shows excellent amplitude characteristics and no attenuation of colors with respect to the luminance signal.

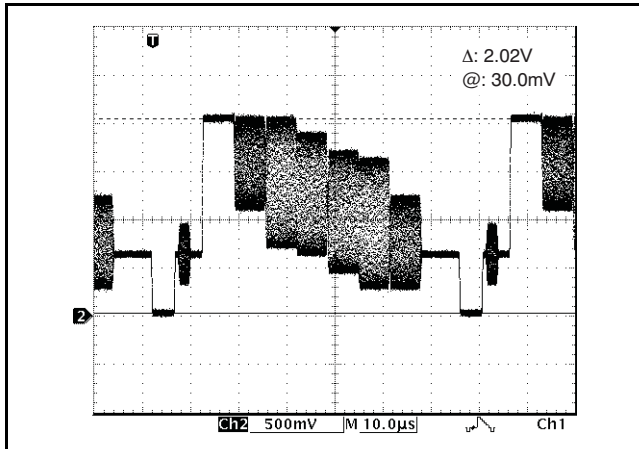

Figure 20. 100/75 Color Bar Signal at OPA362 Output

The CCIR330/5 test pattern requires one of the greatest dynamic ranges, and therefore tests the OPA362 output voltage swing capability. The scope plot shown in [Figure 21](#) has been taken with a 2.8V supply and shows no clipping on the top side of the signal.

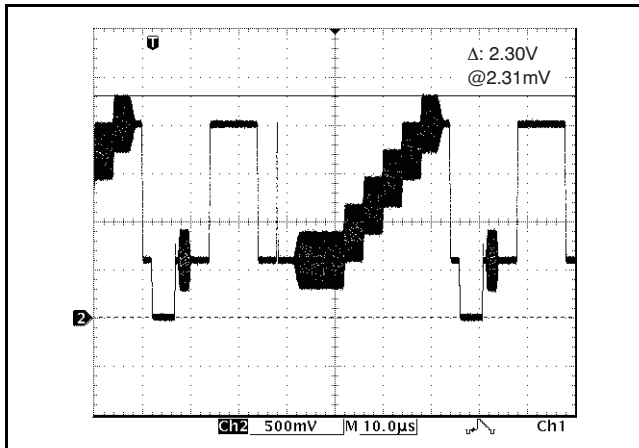

Figure 21. CCIR330/5: No Clipping, Even on 2.8V Supply

The multiburst test patterns have different sine-wave burst sections with the following frequencies: 0.5MHz, 1MHz, 2MHz, 4MHz, 4.8MHz and 5.8MHz with 420mV_{PP}. There is no visible attenuation even at the highest frequencies, which indicates a very flat frequency response of the OPA362. As shown in [Figure 22](#) and [Figure 23](#), the top line illustrates the full signal and the bottom line is a more detailed view of the last three sine wave bursts.

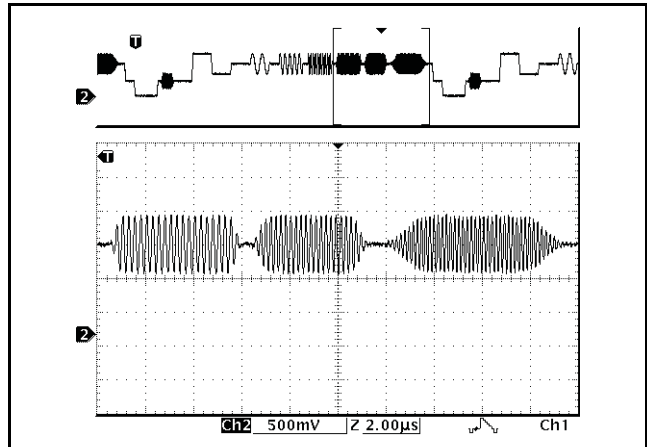

Figure 22. Multiburst Signal (CCIR 18/1) Shows Very Flat Frequency Response

The CCIR17 test pattern contains a 2T and a 20T pulse, as shown in [Figure 23](#). The 2T pulse is used to check for pulse distortion and reflection, and the 20T pulse is used to check for amplitude and group delay exhibits any distortion or group delay artifacts.

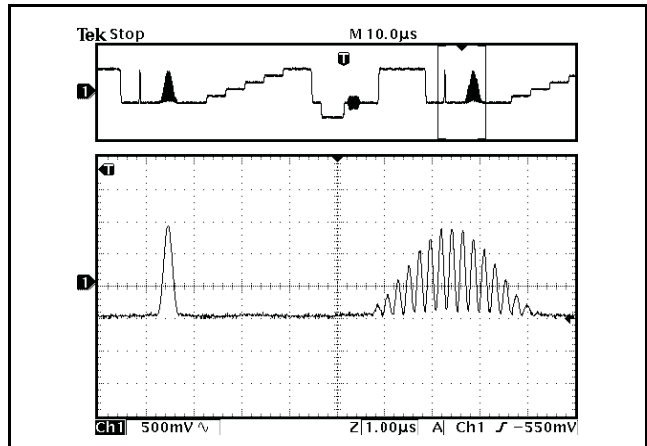

Figure 23. CCIR 17 2T and 20T Pulses Show Little Distortion

Internal Level Shift

Many common video DACs embedded in digital media processors, such as the [OMAP343x processors](#) from Texas Instruments, operate on a single supply (no negative supply). Typically, the lowest point of the sync pulse output by these video DACs is close to 0V. With a 0V input, the output of a common single-supply op amp saturates at a voltage greater than 0V. This effect would clip the sync pulse, and therefore degrade the video signal integrity. The OPA362 employs an internal level shift circuit to avoid clipping. The input signal is typically shifted by approximately 11mV. This shift is well within the linear output voltage range of the OPA362 with a standard 150Ω video load.

Output Swing Capability

Figure 24 shows the true output swing capability of the OPA362 by taking the tip of the input sync pulse to a slightly negative voltage. Even when the output sync tip is at 3mV, the output after the 75Ω series termination continues to show no clipping of the sync pulse.

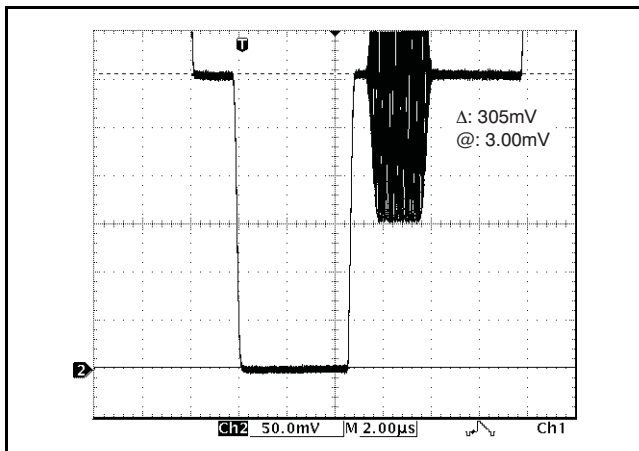

Figure 24. No Clipping of the Sync Pulse

TV-Detect Function

The TV-detection feature of the OPA362 works in conjunction with the OMAP343x (or other processor) to detect if a television is connected to the video output of the device. In order to detect a TV load, the OPA362 is briefly turned off, ideally during the first

vertical sync pulse. For the detection, a simple pull-up resistor to the processor logic supply is used on the output of the OPA362. The voltage level is pulled low if the TV (or other video equipment) is connected, or high if nothing is connected. A GPIO in the processor can be used to read this logic level and decide if a video load is connected. Figure 25 shows a scope plot with the TV disconnected and Figure 26 shows a scope plot with the TV connected; the upper line in both figures is the disable pulse. See Figure 27 for a circuit drawing that shows how to use the TV-detect signal to disable or enable the OPA362.

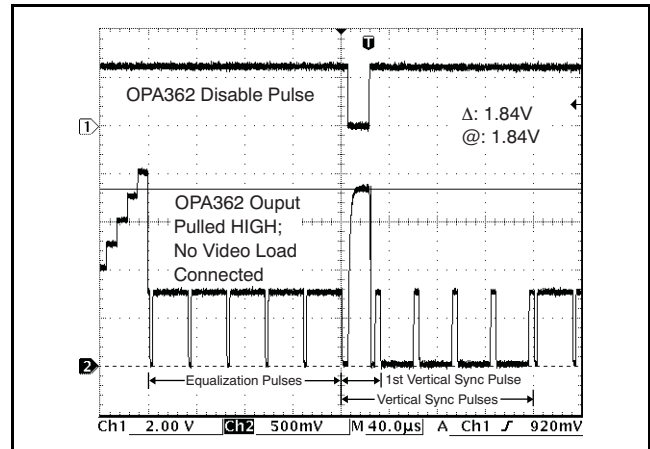

Figure 25. Output of OPA362 Pulled Up to 1.8V During Disable: TV Disconnected

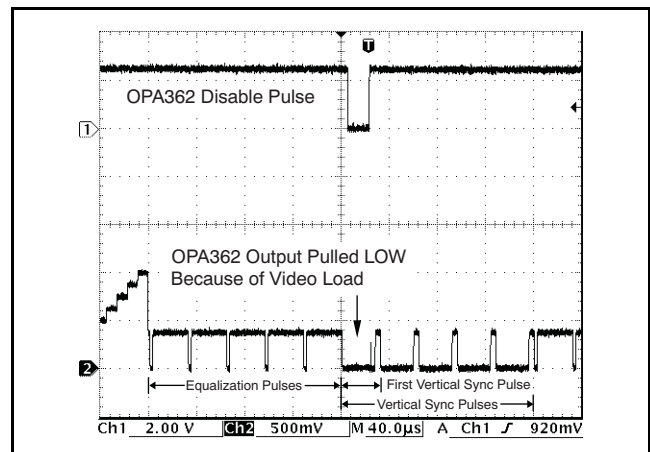
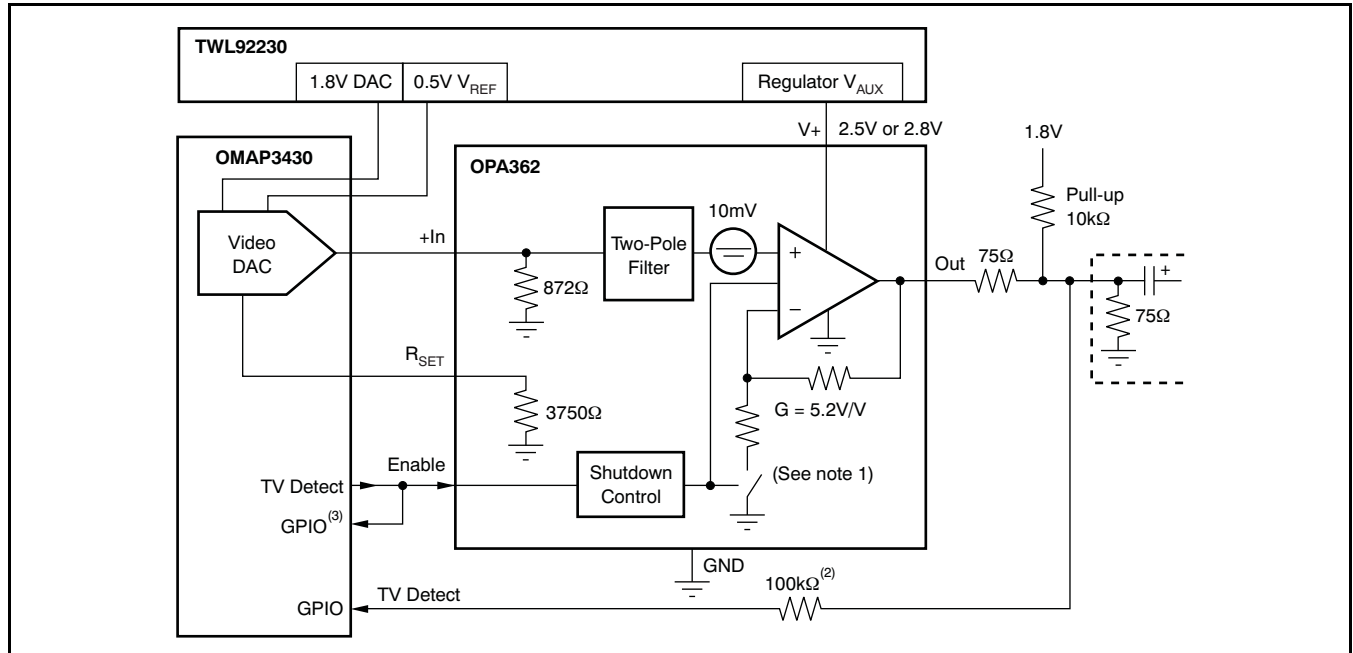

Figure 26. Output of OPA362 Pulled Down: TV Connected



- (1) Closed when enabled during normal operation; open when shut down.
- (2) Protects GPIO against overvoltage conditions during active video transmission.
- (3) GPIO must be able to generate interrupt.

Figure 27. Using TV-Detect Signal to Disable/Enable the OPA362

Disabling the OPA362 also disconnects the internal feedback resistor path to GND, and therefore there is no current flowing from the logic supply through the pull-up resistor to GND if no video load is connected; this architecture helps to conserve battery life. The typical leakage when the output is pulled high and OPA362 is disabled is approximately 300pA.

The following functionality can be achieved by implementing TV-detection:

- Automatic video start by polling the video line periodically.
- Automatic video stop if the TV (or other equipment) is disconnected.

Proper implementation allows to significantly simplify the user interface. For more information, see Application Report [SBOA109, OPA361 and TV Detection](#), available for download at www.ti.com.

PACKAGING INFORMATION

Orderable Device	Status (1)	Package Type	Package Drawing	Pins	Package Qty	Eco Plan (2)	Lead/Ball Finish	MSL Peak Temp (3)	Op Temp (°C)	Top-Side Markings (4)	Samples
OPA362AIDCKR	ACTIVE	SC70	DCK	6	3000	Green (RoHS & no Sb/Br)	CU NIPDAU	Level-2-260C-1 YEAR	-40 to 125	OEA	Samples
OPA362AIDCKT	ACTIVE	SC70	DCK	6	250	Green (RoHS & no Sb/Br)	CU NIPDAU	Level-2-260C-1 YEAR	-40 to 125	OEA	Samples

(1) The marketing status values are defined as follows:

ACTIVE: Product device recommended for new designs.

LIFEBUY: TI has announced that the device will be discontinued, and a lifetime-buy period is in effect.

NRND: Not recommended for new designs. Device is in production to support existing customers, but TI does not recommend using this part in a new design.

PREVIEW: Device has been announced but is not in production. Samples may or may not be available.

OBSOLETE: TI has discontinued the production of the device.

(2) Eco Plan - The planned eco-friendly classification: Pb-Free (RoHS), Pb-Free (RoHS Exempt), or Green (RoHS & no Sb/Br) - please check <http://www.ti.com/productcontent> for the latest availability information and additional product content details.

TBD: The Pb-Free/Green conversion plan has not been defined.

Pb-Free (RoHS): TI's terms "Lead-Free" or "Pb-Free" mean semiconductor products that are compatible with the current RoHS requirements for all 6 substances, including the requirement that lead not exceed 0.1% by weight in homogeneous materials. Where designed to be soldered at high temperatures, TI Pb-Free products are suitable for use in specified lead-free processes.

Pb-Free (RoHS Exempt): This component has a RoHS exemption for either 1) lead-based flip-chip solder bumps used between the die and package, or 2) lead-based die adhesive used between the die and leadframe. The component is otherwise considered Pb-Free (RoHS compatible) as defined above.

Green (RoHS & no Sb/Br): TI defines "Green" to mean Pb-Free (RoHS compatible), and free of Bromine (Br) and Antimony (Sb) based flame retardants (Br or Sb do not exceed 0.1% by weight in homogeneous material)

(3) MSL, Peak Temp. -- The Moisture Sensitivity Level rating according to the JEDEC industry standard classifications, and peak solder temperature.

(4) Multiple Top-Side Markings will be inside parentheses. Only one Top-Side Marking contained in parentheses and separated by a "~" will appear on a device. If a line is indented then it is a continuation of the previous line and the two combined represent the entire Top-Side Marking for that device.

Important Information and Disclaimer: The information provided on this page represents TI's knowledge and belief as of the date that it is provided. TI bases its knowledge and belief on information provided by third parties, and makes no representation or warranty as to the accuracy of such information. Efforts are underway to better integrate information from third parties. TI has taken and continues to take reasonable steps to provide representative and accurate information but may not have conducted destructive testing or chemical analysis on incoming materials and chemicals. TI and TI suppliers consider certain information to be proprietary, and thus CAS numbers and other limited information may not be available for release.

In no event shall TI's liability arising out of such information exceed the total purchase price of the TI part(s) at issue in this document sold by TI to Customer on an annual basis.

TAPE AND REEL INFORMATION

QUADRANT ASSIGNMENTS FOR PIN 1 ORIENTATION IN TAPE

*All dimensions are nominal

Device	Package Type	Package Drawing	Pins	SPQ	Reel Diameter (mm)	Reel Width W1 (mm)	A0 (mm)	B0 (mm)	K0 (mm)	P1 (mm)	W (mm)	Pin1 Quadrant
OPA362AIDCKR	SC70	DCK	6	3000	178.0	9.0	2.4	2.5	1.2	4.0	8.0	Q3
OPA362AIDCKT	SC70	DCK	6	250	178.0	9.0	2.4	2.5	1.2	4.0	8.0	Q3

TAPE AND REEL BOX DIMENSIONS

*All dimensions are nominal

Device	Package Type	Package Drawing	Pins	SPQ	Length (mm)	Width (mm)	Height (mm)
OPA362AIDCKR	SC70	DCK	6	3000	180.0	180.0	18.0
OPA362AIDCKT	SC70	DCK	6	250	180.0	180.0	18.0

DCK (R-PDSO-G6)

PLASTIC SMALL-OUTLINE PACKAGE

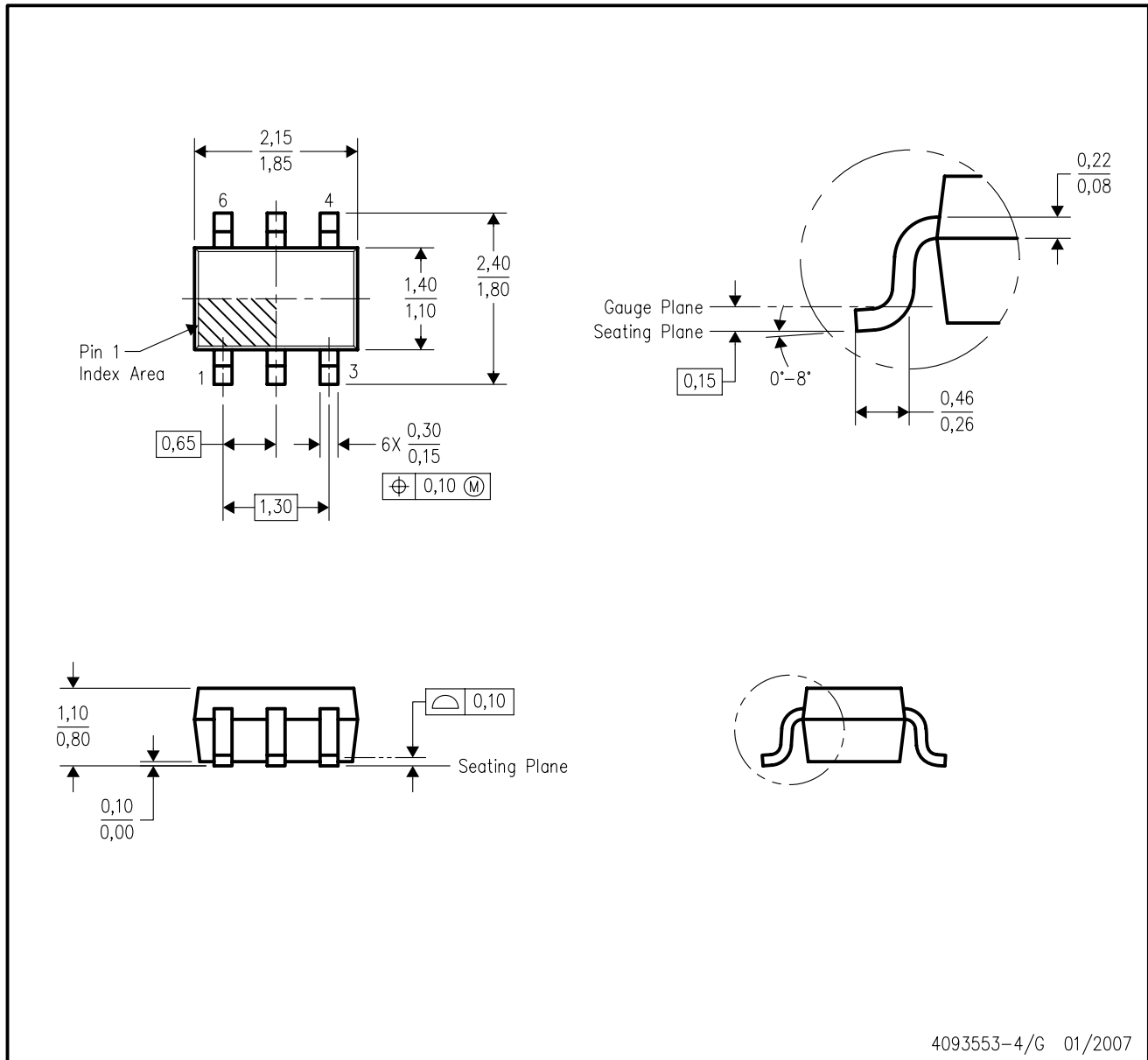

- NOTES:
- A. All linear dimensions are in millimeters.
 - B. This drawing is subject to change without notice.
 - C. Body dimensions do not include mold flash or protrusion. Mold flash and protrusion shall not exceed 0.15 per side.
 - D. Falls within JEDEC MO-203 variation AB.

DCK (R-PDSO-G6)

PLASTIC SMALL OUTLINE

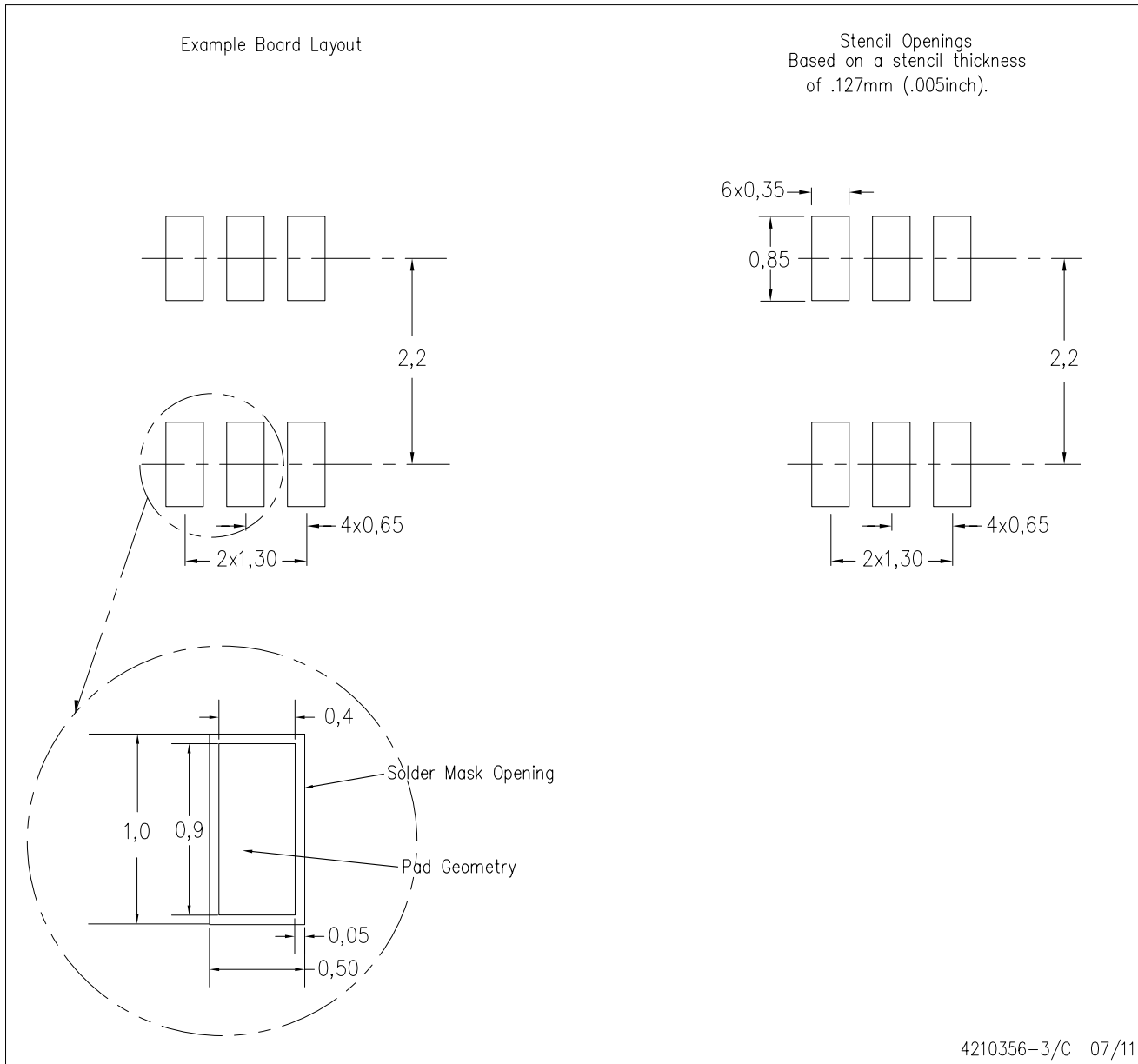

- NOTES:
- All linear dimensions are in millimeters.
 - This drawing is subject to change without notice.
 - Customers should place a note on the circuit board fabrication drawing not to alter the center solder mask defined pad.
 - Publication IPC-7351 is recommended for alternate designs.
 - Laser cutting apertures with trapezoidal walls and also rounding corners will offer better paste release. Customers should contact their board assembly site for stencil design recommendations. Example stencil design based on a 50% volumetric metal load solder paste. Refer to IPC-7525 for other stencil recommendations.

IMPORTANT NOTICE

Texas Instruments Incorporated and its subsidiaries (TI) reserve the right to make corrections, enhancements, improvements and other changes to its semiconductor products and services per JESD46, latest issue, and to discontinue any product or service per JESD48, latest issue. Buyers should obtain the latest relevant information before placing orders and should verify that such information is current and complete. All semiconductor products (also referred to herein as "components") are sold subject to TI's terms and conditions of sale supplied at the time of order acknowledgment.

TI warrants performance of its components to the specifications applicable at the time of sale, in accordance with the warranty in TI's terms and conditions of sale of semiconductor products. Testing and other quality control techniques are used to the extent TI deems necessary to support this warranty. Except where mandated by applicable law, testing of all parameters of each component is not necessarily performed.

TI assumes no liability for applications assistance or the design of Buyers' products. Buyers are responsible for their products and applications using TI components. To minimize the risks associated with Buyers' products and applications, Buyers should provide adequate design and operating safeguards.

TI does not warrant or represent that any license, either express or implied, is granted under any patent right, copyright, mask work right, or other intellectual property right relating to any combination, machine, or process in which TI components or services are used. Information published by TI regarding third-party products or services does not constitute a license to use such products or services or a warranty or endorsement thereof. Use of such information may require a license from a third party under the patents or other intellectual property of the third party, or a license from TI under the patents or other intellectual property of TI.

Reproduction of significant portions of TI information in TI data books or data sheets is permissible only if reproduction is without alteration and is accompanied by all associated warranties, conditions, limitations, and notices. TI is not responsible or liable for such altered documentation. Information of third parties may be subject to additional restrictions.

Resale of TI components or services with statements different from or beyond the parameters stated by TI for that component or service voids all express and any implied warranties for the associated TI component or service and is an unfair and deceptive business practice. TI is not responsible or liable for any such statements.

Buyer acknowledges and agrees that it is solely responsible for compliance with all legal, regulatory and safety-related requirements concerning its products, and any use of TI components in its applications, notwithstanding any applications-related information or support that may be provided by TI. Buyer represents and agrees that it has all the necessary expertise to create and implement safeguards which anticipate dangerous consequences of failures, monitor failures and their consequences, lessen the likelihood of failures that might cause harm and take appropriate remedial actions. Buyer will fully indemnify TI and its representatives against any damages arising out of the use of any TI components in safety-critical applications.

In some cases, TI components may be promoted specifically to facilitate safety-related applications. With such components, TI's goal is to help enable customers to design and create their own end-product solutions that meet applicable functional safety standards and requirements. Nonetheless, such components are subject to these terms.

No TI components are authorized for use in FDA Class III (or similar life-critical medical equipment) unless authorized officers of the parties have executed a special agreement specifically governing such use.

Only those TI components which TI has specifically designated as military grade or "enhanced plastic" are designed and intended for use in military/aerospace applications or environments. Buyer acknowledges and agrees that any military or aerospace use of TI components which have **not** been so designated is solely at the Buyer's risk, and that Buyer is solely responsible for compliance with all legal and regulatory requirements in connection with such use.

TI has specifically designated certain components as meeting ISO/TS16949 requirements, mainly for automotive use. In any case of use of non-designated products, TI will not be responsible for any failure to meet ISO/TS16949.

Products

Audio	www.ti.com/audio
Amplifiers	amplifier.ti.com
Data Converters	dataconverter.ti.com
DLP® Products	www.dlp.com
DSP	dsp.ti.com
Clocks and Timers	www.ti.com/clocks
Interface	interface.ti.com
Logic	logic.ti.com
Power Mgmt	power.ti.com
Microcontrollers	microcontroller.ti.com
RFID	www.ti-rfid.com
OMAP Applications Processors	www.ti.com/omap
Wireless Connectivity	www.ti.com/wirelessconnectivity

Applications

Automotive and Transportation	www.ti.com/automotive
Communications and Telecom	www.ti.com/communications
Computers and Peripherals	www.ti.com/computers
Consumer Electronics	www.ti.com/consumer-apps
Energy and Lighting	www.ti.com/energy
Industrial	www.ti.com/industrial
Medical	www.ti.com/medical
Security	www.ti.com/security
Space, Avionics and Defense	www.ti.com/space-avionics-defense
Video and Imaging	www.ti.com/video

TI E2E Community

e2e.ti.com

Looking for pricing, stock, or lifecycle information?

Click below to explore more details on WIN SOURCE:

 [View OPA362AIDCKR](#) on WIN SOURCE

 [Texas Instruments](#) Information

Optimize Your Supply Chain with WIN SOURCE Solutions

-  Global Sourcing Solution
-  Obsolete Management
-  Cost Control Management
-  Shortage Management
-  Alternative Solution
-  Excess Inventory Management