



THE DATASHEET OF ICPL3120



ICPL3120



DESCRIPTION

The ICPL3120 consists of an Infrared Light Emitting Diode optically coupled to an Integrated Circuit with a Power Driving Output. ICPL3120 is ideally suitable to drive the Power IGBT and MOSFET in Inverters of Motor Controls and in Power Supplies.

The 2.5A peak output current is capable to direct drive IGBT/MOSFET up to ratings of 1200V/100A. For IGBTs with higher ratings, ICPL3120 can be used to drive a discrete power stage which drives the IGBT gate.

FEATURES

- $\pm 2.5A$ Maximum Peak Output Current
- 35kV/ μs Minimum Common Mode Rejection at V_{CM} 1500V
- Maximum Propagation Delay 500ns
- Maximum Propagation Delay Difference 100ns
- Wide Operating Voltage Range
 V_{CC} 15 to 30 V
- Maximum Supply Current I_{CC} 3.5mA
- Under Voltage Lock Out (UVLO) Protection with Hysteresis
- Guaranteed Performance over Temperature Range - 40°C to +105°C
- MSL 1
- Lead Free and RoHS Compliant
- Safety Approvals Pending

APPLICATIONS

- IGBT/MOSFET Gate Drive
- UPS
- Inverters
- AC Brushless and DC Motor Drives

ORDER INFORMATION

- Add G after PN for 10mm lead spacing
- Add SM after PN for Surface Mount
- Add SMT&R after PN for Surface Mount Tape & Reel

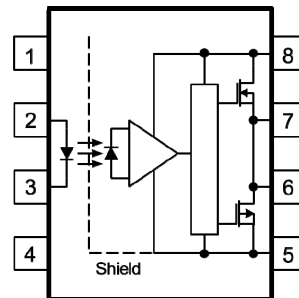

1	NC
2	Anode
3	Cathode
4	NC
5	GND (V_{EE})
6	V_O
7	V_O
8	V_{CC}

A 0.1 μF bypass Capacitor must be connected between Pins 8 and 5.

ABSOLUTE MAXIMUM RATINGS ($T_A = 25^\circ C$)

Stresses exceeding the absolute maximum ratings can cause permanent damage to the device.

Exposure to absolute maximum ratings for long periods of time can adversely affect reliability.

Input

Forward Current	20mA
Forward Peak Current	1A
(Pulse Width $\leq 1\mu s$, 300pps)	
Forward Current Rise / Fall Time	500ns
Reverse Voltage	5V
Power dissipation	45mW

Output

Peak Output Current	$\pm 2.5A$
(Exponential waveform, Pulse Width $\leq 0.3\mu s$, $f \leq 15kHz$)	
Operating Frequency	50kHz
(Exponential waveform, $I_{O(Peak)} \leq 12.5A$, Pulse Width $\leq 0.3\mu s$)	
Supply Voltage ($V_{CC} - V_{EE}$)	0V to 35V
Output Voltage	0V to V_{CC}
Power Dissipation	250mW

Total Package

Isolation Voltage	5000V _{RMS}
Total Power Dissipation	295mW
Operating Temperature	-40 to 105 °C
Storage Temperature	-55 to 125 °C
Junction Temperature	125 °C Max
Lead Soldering Temperature (10s)	260°C

ISOCOM COMPONENTS 2004 LTD

Unit 25B, Park View Road West, Park View Industrial Estate
Hartlepool, Cleveland, TS25 1PE, United Kingdom
Tel : +44 (0)1429 863 609 Fax : +44 (0)1429 863 581
e-mail : sales@isocom.co.uk
<http://www.isocom.com>

ISOCOM COMPONENTS ASIA LTD

Hong Kong Office,
Block A, 8/F, Wah Hing Industrial mansion,
36 Tai Yau Street, San Po Kong, Kowloon, Hong Kong.
Tel : +852 2995 9217 Fax : +852 8161 6292
e-mail : sales@isocom.com.hk

ICPL3120

Truth Table

LED	$V_{CC} - V_{EE}$ (Turn ON, +ve going)	$V_{CC} - V_{EE}$ (Turn OFF -ve going)	V_o
OFF	0 – 30V	0 – 30V	LOW
ON	0 – 11.0V	0 – 9.5V	LOW
ON	11.0 – 13.5V	9.5 – 12.0V	TRANSITION
ON	13.5 – 30V	12 – 30V	HIGH

Recommended Operating Conditions

Parameter	Symbol	Min	Max	Unit
Operating Temperature	T_A	- 40	105	°C
Supply Voltage	$V_{CC} - V_{EE}$	15	30	V
Input Current (ON)	$I_{F(ON)}$	7	16	mA
Input Voltage (OFF)	$V_{F(OFF)}$	0	0.8	V



ICPL3120

ELECTRICAL CHARACTERISTICS (Typical Values at $V_{CC} - V_{EE} = 30V$ and $T_A = 25^\circ C$,
Minimum and Maximum Values at Recommended Operating Conditions,
unless otherwise specified)

INPUT

Parameter	Symbol	Test Condition	Min	Typ.	Max	Unit
Forward Voltage	V_F	$I_F = 10mA$	1.2	1.37	1.8	V
Forward Voltage Temperature Coefficient	$\Delta V_F / \Delta T$	$I_F = 10mA$		-1.237		mV/°C
Reverse Voltage	V_R	$I_R = 10\mu A$	5			V
Input Threshold Current (Low to High)	I_{FLH}	$V_{CC} = 30V$ $V_O > 5V$		1.8	5	mA
Input Threshold Voltage (High to Low)	V_{FHL}	$V_{CC} = 30V$ $V_O < 5V$	0.8			V
Input Capacitance	C_{IN}	$V_F = 0V, f = 1MHz$		33		pF

OUTPUT

Parameter	Symbol	Test Condition	Min	Typ.	Max	Unit
High Level Supply Current	I_{CCH}	$I_F = 10mA, V_{CC} = 30V$ $V_O = \text{Open}$		2.4	3.5	mA
Low Level Supply Current	I_{CCL}	$I_F = 0mA, V_{CC} = 30V$ $V_O = \text{Open}$		2.5	3.5	mA
High Level Output Current	I_{OH}	Maximum Pulse Width = 50 μs $V_O = V_{CC} - 1.5V$ Maximum Pulse Width = 10 μs $V_O = V_{CC} - 4V$			-1.0 -2.5	A
Low Level Output Current	I_{OL}	Maximum Pulse Width = 50 μs $V_O = V_{EE} + 1.5V$ Maximum Pulse Width = 10 μs $V_O = V_{EE} + 4V$	1.0 2.5			A
High Level Output Voltage	V_{OH}	$I_F = 10mA, I_O = -100mA$	$V_{CC} - 0.3$	$V_{CC} - 0.1$		V
Low Level Output Voltage	V_{OL}	$I_F = 0mA, I_O = 100mA$		$V_{EE} + 0.1$	$V_{EE} + 0.25$	V
UVLO Threshold	V_{UVLO+}	$V_O > 5V, I_F = 10mA$	11.0	12.7	13.5	V
	V_{UVLO-}	$V_O < 5V, I_F = 10mA$	9.5	11.2	12.0	V
UVLO Hysteresis	$UVLO_{HYS}$			1.5		V



ICPL3120

ELECTRICAL CHARACTERISTICS (Typical Values at $V_{CC} - V_{EE} = 30V$ and $T_A = 25^\circ C$,
Minimum and Maximum Values at Recommended Operating Conditions,
unless otherwise specified)

SWITCHING

Parameter	Symbol	Test Condition	Min	Typ.	Max	Unit
Propagation Delay Time to High Output Level	t_{PLH}	$I_F = 7$ to $16mA$, $V_{CC} = 15$ to $30V$, $V_{EE} = 0V$, $R_g = 10\Omega$, $C_g = 25nF$, $f = 10kHz$, Duty Cycle = 50%	50	130	500	ns
Propagation Delay Time to Low Output Level	t_{PHL}		50	130	500	
Pulse Width Distortion $ t_{PHL} - t_{PLH} $ for any given device	PWD			5	70	
Propagation Delay Difference ($t_{PHL} - t_{PLH}$) between any two Devices	PDD			-100		100
Output Rise Time (10% to 90%)	t_r				35	
Output Fall Time (90% to 10%)	t_f				35	
UVLO Turn On Delay	$t_{UVLO ON}$	$I_F = 10mA$, $V_O > 5V$		1.6		μs
UVLO Turn Off Delay	$t_{UVLO OFF}$	$I_F = 10mA$, $V_O < 5V$		0.4		μs
Common Mode Transient Immunity at High Output Level	CM_H	$I_F = 10$ to $16mA$, $V_{CC} = 30V$, $V_{CM} = 1500V$, $T_A = 25^\circ C$	35	50		$kV/\mu s$
Common Mode Transient Immunity at Low Output Level	CM_L	$V_F = 0V$, $V_{CC} = 30V$, $V_{CM} = 1500V$, $T_A = 25^\circ C$	35	50		$kV/\mu s$

ICPL3120

ELECTRICAL CHARACTERISTICS (Typical Values at $V_{CC} - V_{EE} = 30V$ and $T_A = 25^\circ C$, Minimum and Maximum Values at Recommended Operating Conditions, unless otherwise specified)

ISOLATION

Parameter	Symbol	Test Condition	Min	Typ.	Max	Unit
Insulation Voltage	V_{ISO}	R.H. = 40% - 60%, $T_A = 25^\circ C$ $t = 1 \text{ min}$,	5000			V
Input - Output Resistance	R_{I-O}	$V_{I-O} = 500VDC$		10^{12}		Ω
Input - Output Capacitance	C_{I-O}	$f = 1MHz$		0.92		pF

Note :

1. A 0.1uF or bigger bypass capacitor must be connected across pin 8 and pin 5.
2. PDD is the difference of t_{PHL} and t_{PLH} between any two ICPL3120 under same test conditions.
3. Common Mode Transient Immunity in High stage is the maximum tolerable negative dV_{CM}/dt on the trailing edge of the common mode impulse signal, V_{CM} , to assure that the output will remain high ($V_O > 15V$).
4. Common Mode Transient Immunity in Low stage is the maximum tolerable positive dV_{CM}/dt on the leading edge of the common mode impulse signal, V_{CM} , to assure that the output will remain low ($V_O < 1V$).

ICPL3120

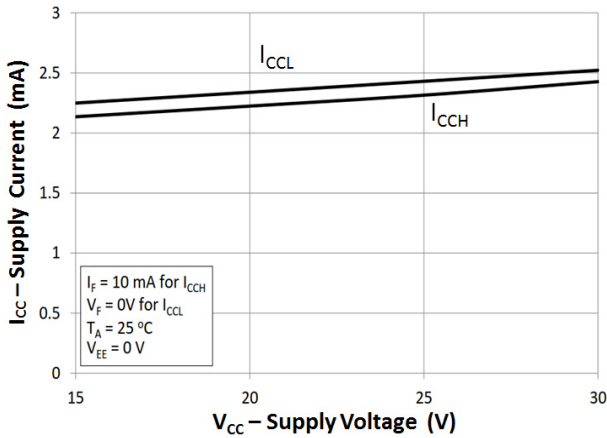

Fig 1 Supply Current vs Supply Voltage

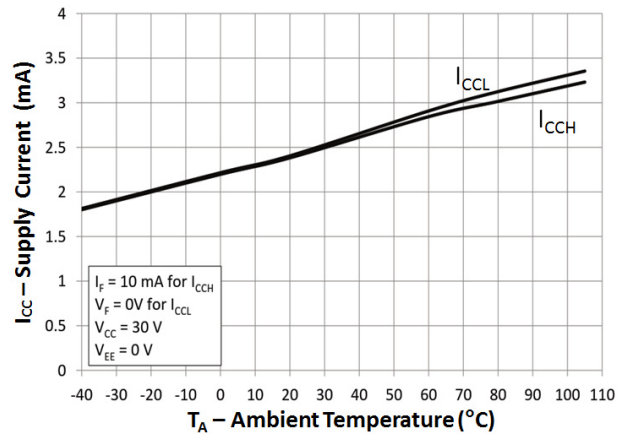

Fig 2 Supply Current vs Ambient Temperature

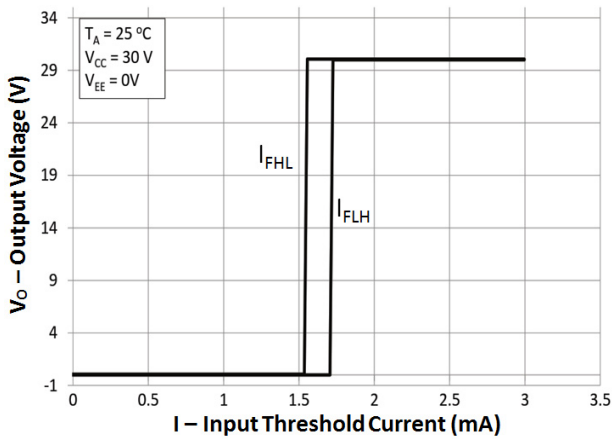

Fig 3 Transfer Characteristics

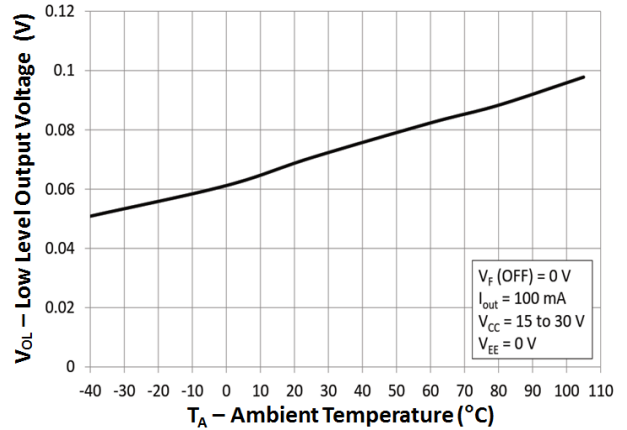

Fig 4 Output Low Voltage vs Ambient Temperature

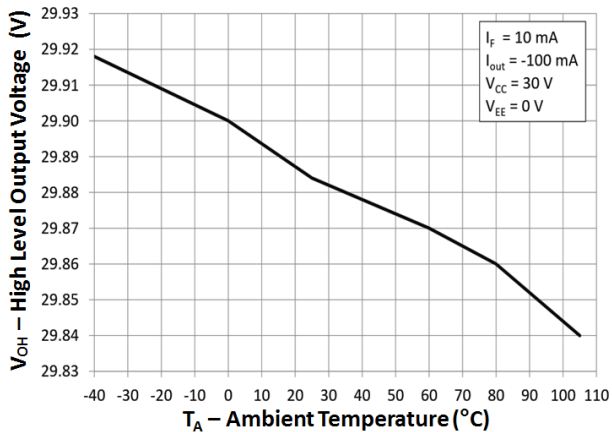

Fig 5 Output High Voltage vs Ambient Temperature

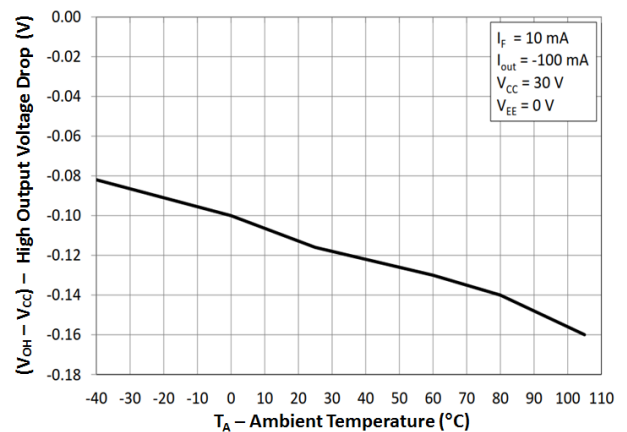

Fig 6 Output High Voltage Drop vs Ambient Temperature

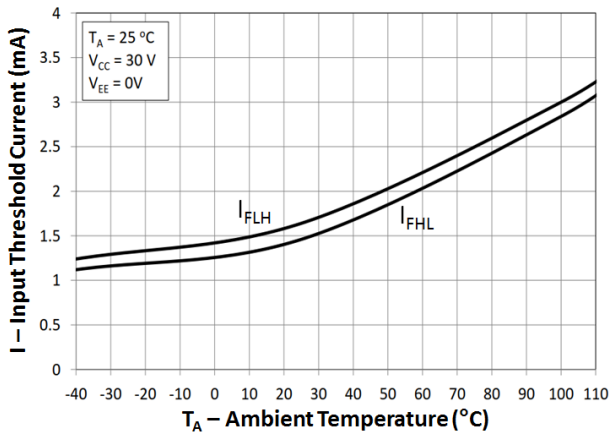

Fig 7 Input Threshold Current vs Ambient Temperature

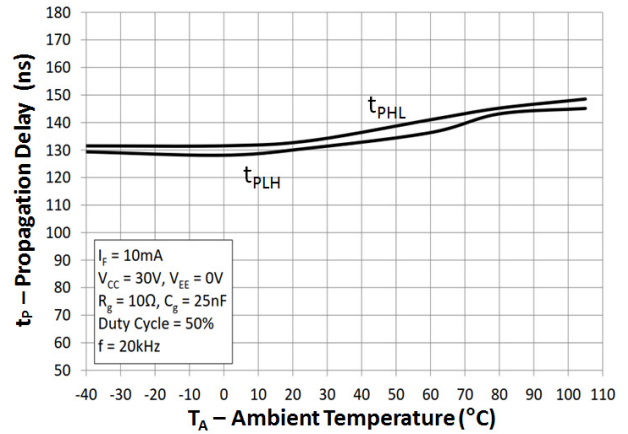

Fig 8 Propagation Delay vs Ambient Temperature

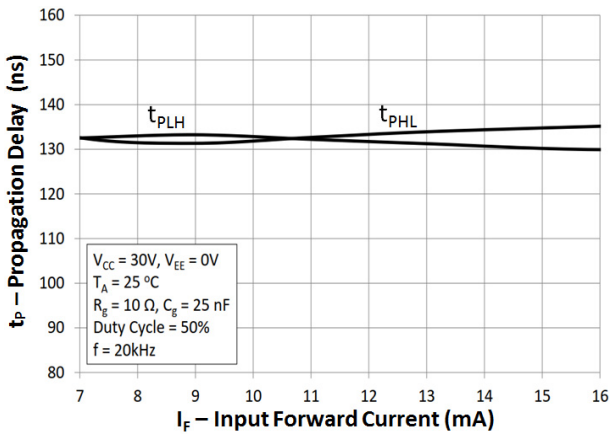

Fig 9 Propagation Delay vs Forward Current

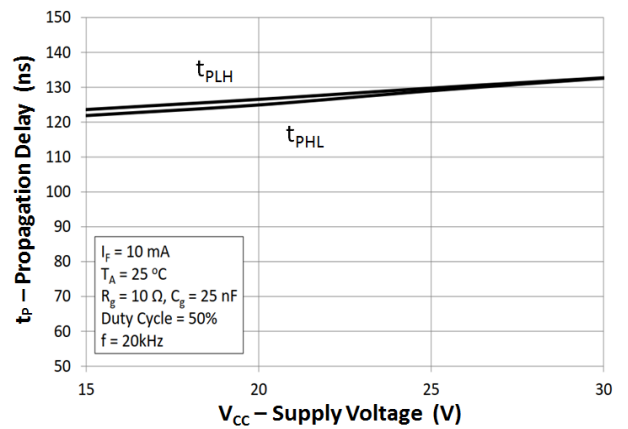

Fig 10 Propagation Delay vs Supply Voltage

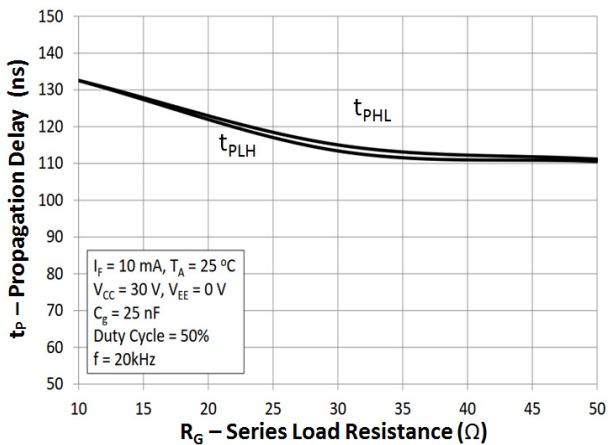

Fig 11 Propagation Delay vs Series Load Resistance

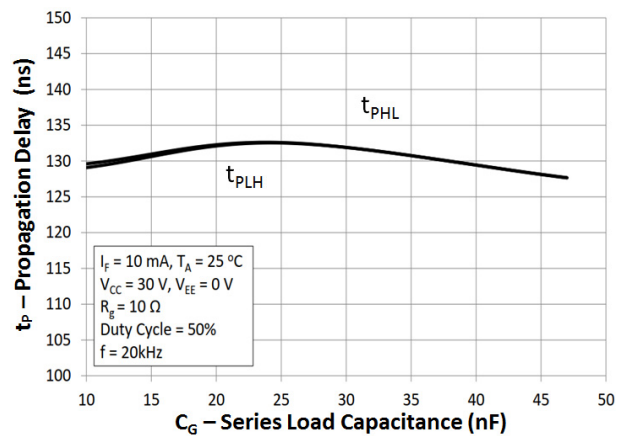

Fig 12 Propagation Delay vs Series Load Capacitance

ICPL3120

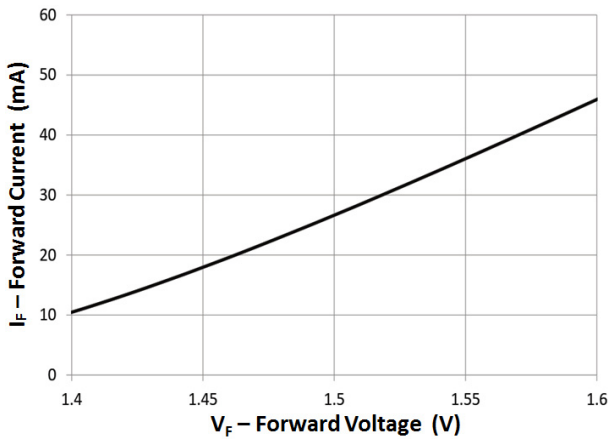
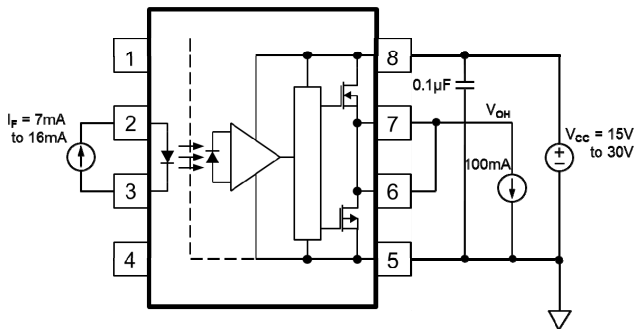
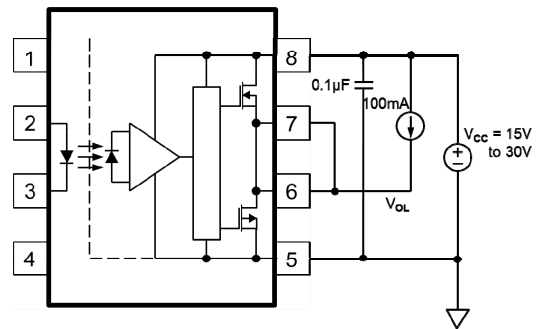

Fig 13 Forward Current vs Forward Voltage



V_{OH} Test Circuit



V_{OL} Test Circuit

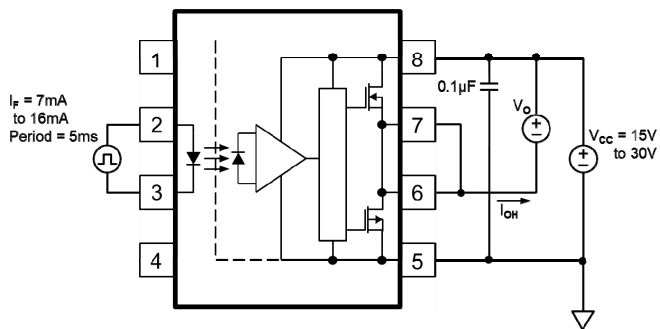

I_{OH} Test Circuit

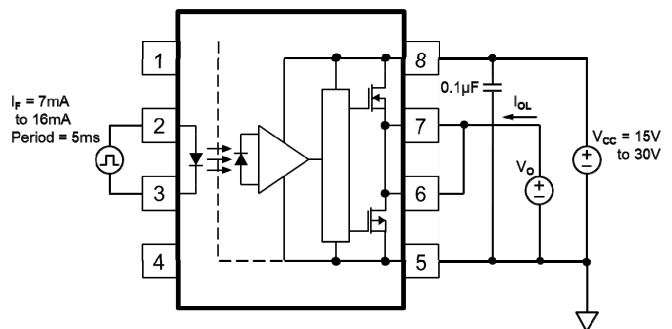

I_{OL} Test Circuit

ICPL3120

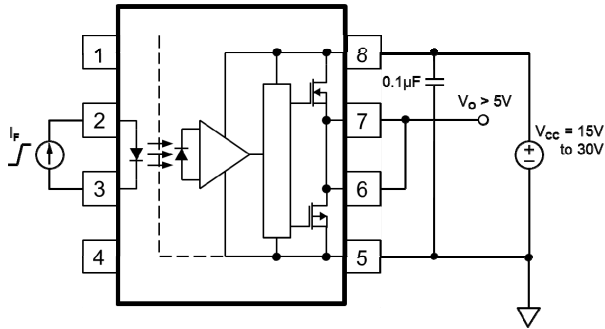

I_{FLH} Test Circuit

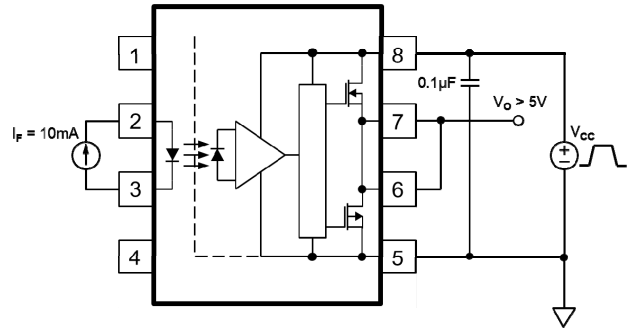

UVLO Test Circuit

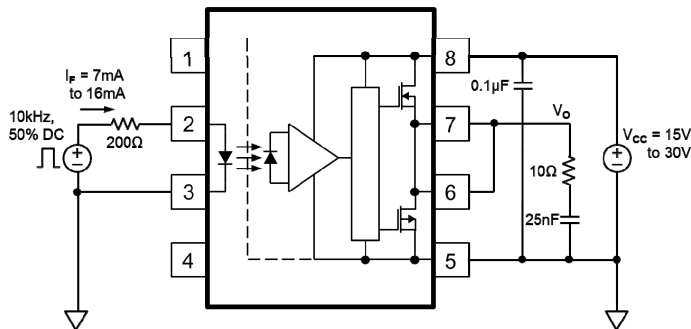

t_r , t_f , t_{PLH} and t_{PHL} Test Circuit

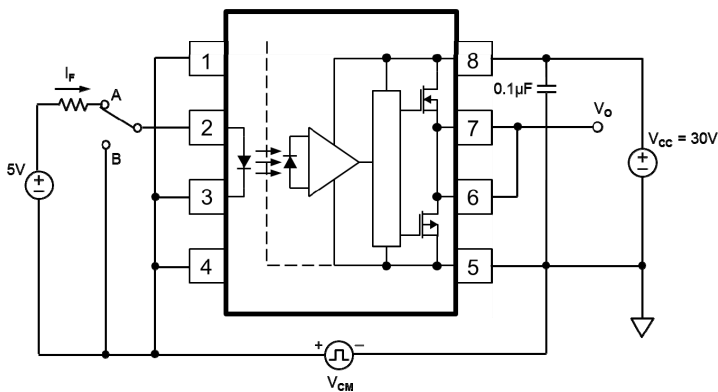
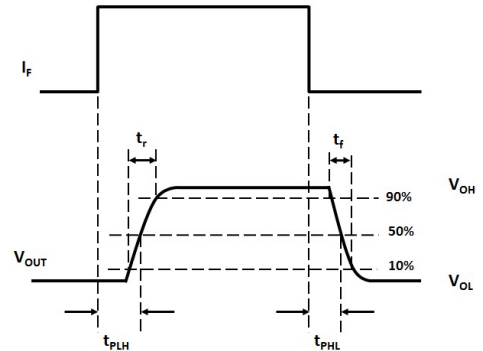

CMR Test Circuit

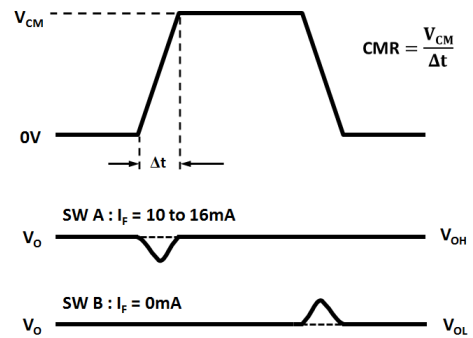

ICPL3120

ORDER INFORMATION

ICPL3120			
After PN	PN	Description	Packing quantity
None	ICPL3120	Standard DIP8	50 pcs per tube
G	ICPL3120G	10mm Lead Spacing	50 pcs per tube
SM	ICPL3120SM	Surface Mount	50 pcs per tube
SMT&R	ICPL3120SMT&R	Surface Mount Tape & Reel	1000 pcs per reel

DEVICE MARKING

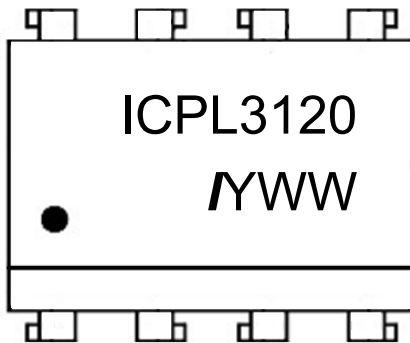

ICPL3120 denotes Device Part Number
 I denotes Isocom
 Y denotes 1 digit Year code
 WW denotes 2 digit Week code

ICPL3120

PACKAGE DIMENSIONS in mm (inch)

DIP

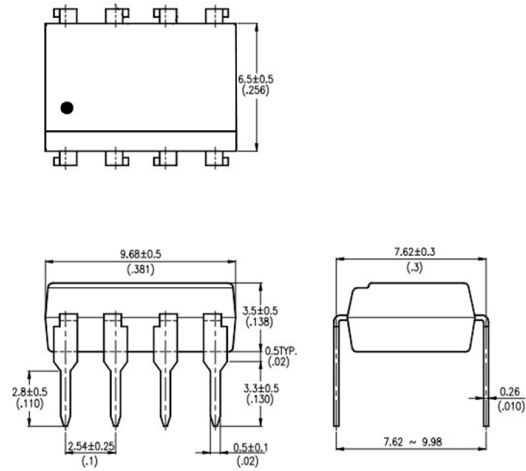

G Form

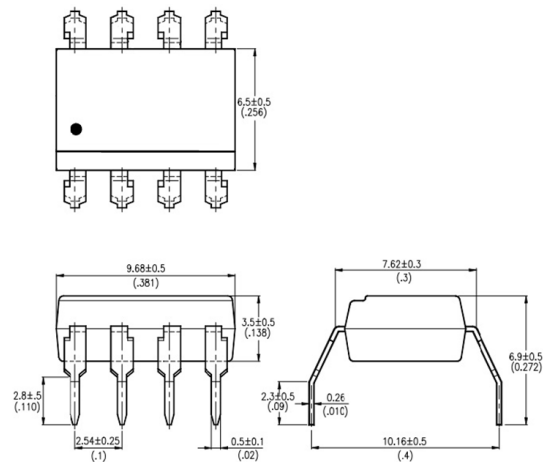

SMD

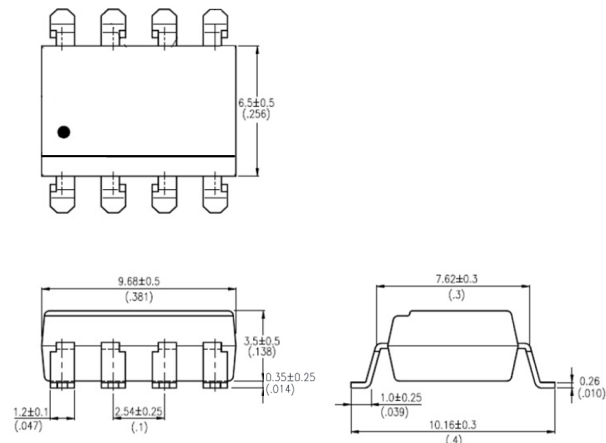

ICPL3120

RECOMMENDED SOLDER PAD LAYOUT (mm)

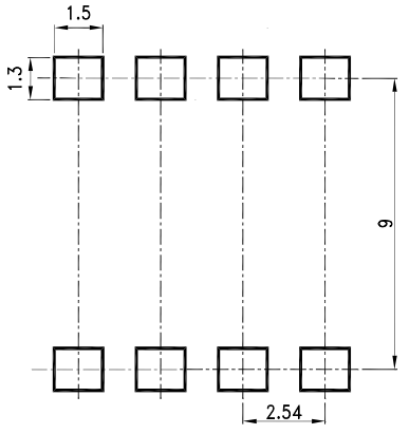

TAPE AND REEL PACKAGING

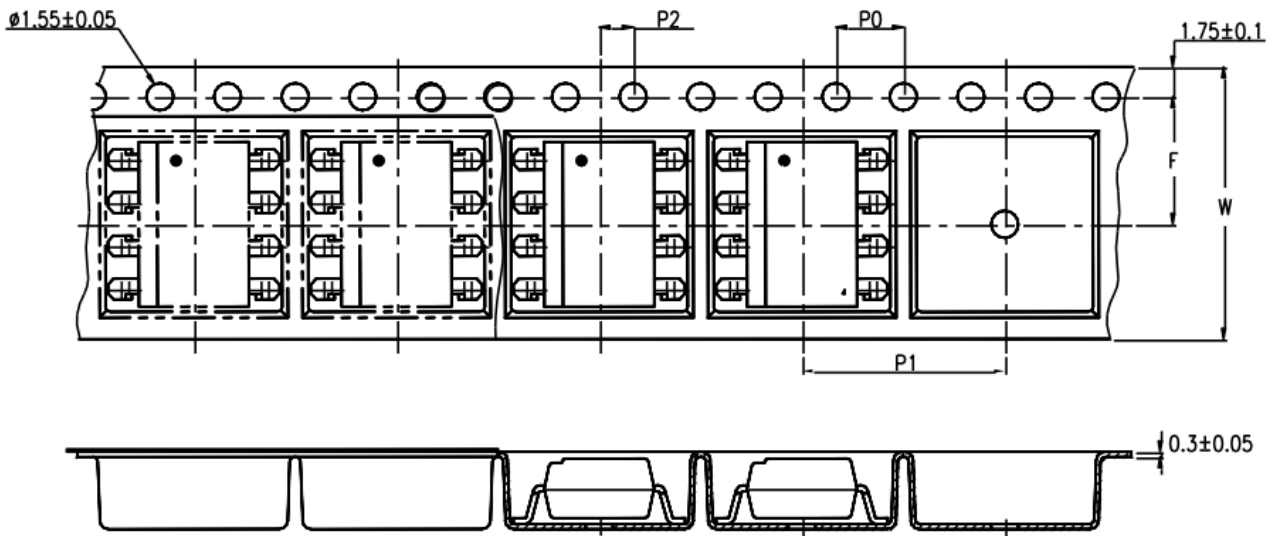

Description	Symbol	Dimension mm (inch)
Tape Width	W	16 ± 0.3 (0.63)
Pitch of Sprocket Holes	P ₀	4 ± 0.1 (0.15)
Distance of Compartment to Sprocket Holes	F	7.5 ± 0.1 (0.295)
	P ₂	2 ± 0.1 (0.079)
Distance of Compartment to Compartment	P ₁	12 ± 0.1 (0.47)

IR REFLOW SOLDERING TEMPERATURE PROFILE
Note : One Time Reflow Soldering is Recommended.
Do Not Immerse Device Body in Solder Paste.

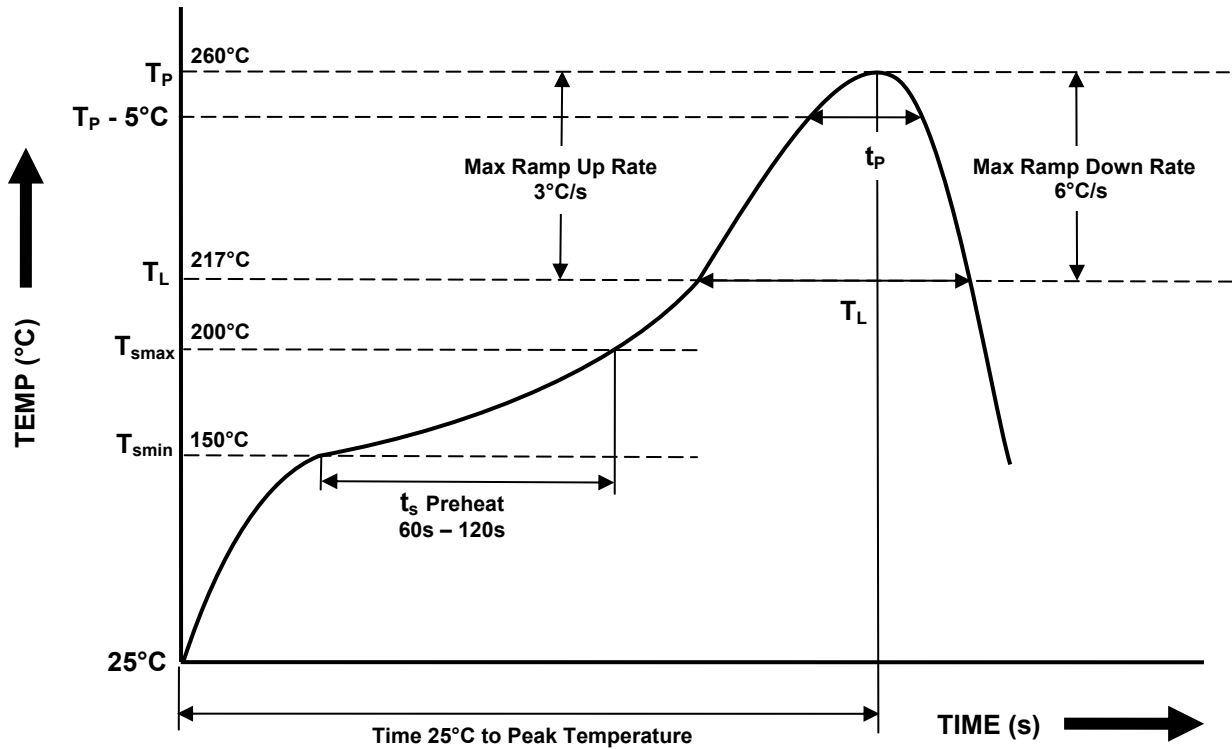

Profile Details	Conditions
Preheat - Min Temperature (T _{SMIN}) - Max Temperature (T _{SMAX}) - Time T _{SMIN} to T _{SMAX} (t _s)	150°C 200°C 60s - 120s
Soldering Zone - Peak Temperature (T _P) - Time at Peak Temperature - Liquidous Temperature (T _L) - Time within 5°C of Actual Peak Temperature (T _P - 5°C) - Time maintained above T _L (t _L) - Ramp Up Rate (T _L to T _P) - Ramp Down Rate (T _P to T _L)	260°C 10s max 217°C 30s max 60s - 100s 3°C/s max 6°C/s max
Average Ramp Up Rate (T _{smax} to T _P)	3°C/s max
Time 25°C to Peak Temperature	8 minutes max



DISCLAIMER

Isocom Components is continually working to improve the quality and reliability of its products. Nevertheless, semiconductor devices in general can malfunction or fail due to their inherent electrical sensitivity and vulnerability to physical stress. It is the responsibility of the buyer, when utilizing Isocom Components products, to comply with the standards of safety in making a safe design for the entire system, and to avoid situations in which a malfunction or failure of such Isocom Components products could cause loss of human life, bodily injury or damage to property.

In developing your designs, please ensure that Isocom Components products are used within specified operating ranges as set forth in the most recent Isocom Components products specifications.

The Isocom Components products listed in this document are intended for usage in general electronics applications (computer, personal equipment, office equipment, measuring equipment, industrial robotics, domestic appliances, etc.). These Isocom Components products are neither intended nor warranted for usage in equipment that requires extraordinarily high quality and/or reliability or a malfunction or failure of which may cause loss of human life or bodily injury ("Unintended Usage"). Unintended Usage include atomic energy control instruments, airplane or spaceship instruments, transportation Instruments, traffic signal instruments, combustion control instruments, medical Instruments, all types of safety devices, etc... Unintended Usage of Isocom Components products listed in this document shall be made at the customer's own risk.

Gallium arsenide (GaAs) is a substance used in the products described in this document. GaAs dust and fumes are toxic. Do not break, cut or pulverize the product, or use chemicals to dissolve them. When disposing of the products, follow the appropriate regulations. Do not dispose of the products with other industrial waste or with domestic garbage.

The products described in this document are subject to the foreign exchange and foreign trade laws.

The information contained herein is presented only as a guide for the applications of our products. No responsibility is assumed by Isocom Components for any infringements of intellectual property or other rights of the third parties which may result from its use. No license is granted by implication or otherwise under any intellectual property or other rights of Isocom Components or others.

The information contained herein is subject to change without notice.

Looking for pricing, stock, or lifecycle information?

Click below to explore more details on WIN SOURCE:

- [View ICPL3120 on WIN SOURCE](#)
- [Isocom Components 2004 LTD Information](#)

Optimize Your Supply Chain with WIN SOURCE Solutions

- ✓ Global Sourcing Solution
- ✓ Obsolete Management
- ✓ Cost Control Management
- ✓ Shortage Management
- ✓ Alternative Solution
- ✓ Excess Inventory Management