



**THE DATASHEET OF
PS9513L3-E3-AX**



PS9513, PS9513L, PS9513L2, PS9513L3

1 Mbps, OPEN COLLECTOR OUTPUT, FOR GATE
 DRIVE INTERFACE INTELLIGENT POWER MODULE
 8 mm CREEPAGE 8-PIN DIP HIGH-SPEED
 PHOTOCOUPLER

Data Sheet
 R08DS0126EJ0200
 Rev.2.00
 Apr 13, 2015

Description

The PS9513, PS9513L1, PS9513L2 and PS9513L3 are optically coupled isolators containing a GaAlAs LED on the input side and a photo diode and a signal processing circuit on the output side on one chip.

The PS9513 is designed specifically for high common mode transient immunity (CMR) and low pulse width distortion with operating temperature. It is suitable for IPM drive.

The PS9513L1 is lead bending type for long creepage distance.

The PS9513L2 is lead bending type for long creepage distance (Gull-wing) for surface mount.

The PS9513L3 is lead bending type (Gull-wing) for surface mounting.

Features

- Long creepage distance (8 mm MIN. : PS9513L1, PS9513L2)
- High common mode transient immunity ($CM_H, CM_L = \pm 15 \text{ kV}/\mu\text{s}$ MIN)
- High-speed response ($t_{PHL} = 500 \text{ ns}$ MAX., $t_{PLH} = 750 \text{ ns}$ MAX.)
- Maximum propagation delays ($t_{PLH} - t_{PHL} = 270 \text{ ns}$ TYP.)
- Pulse width distortion ($|t_{PHL} - t_{PLH}| = 270 \text{ ns}$ TYP.)
- Open collector output
- Ordering number of tape product : PS9513L2-E3 : 1 000 pcs/reel
 : PS9513L3-E3 : 1 000 pcs/reel
- Pb-Free product
- Safety standards
 - UL approved: No. E72422
 - CSA approved: No. CA 101391 (CA5A, CAN/CSA-C22.2 60065, 60950)
 - BSI approved: No. 8937, 8938
 - SEMKO approved: No. 1308848
 - NEMKO approved: No. P13217067
 - DEMKO approved: No. D-02380
 - FIMKO approved: No. FI 27913
 - DIN EN60747-5-5 (VDE0884-5):2011-11 approved: No. 40024069 (Option)

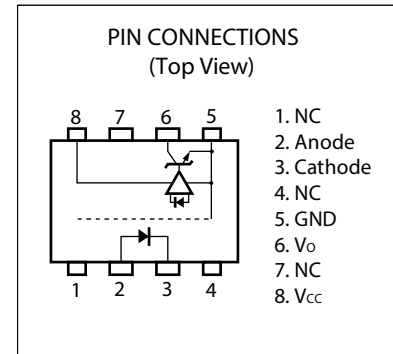

APPLICATIONS

- IPM Driver
- General purpose inverter

PACKAGE DIMENSIONS (UNIT: mm)

- DIP Type

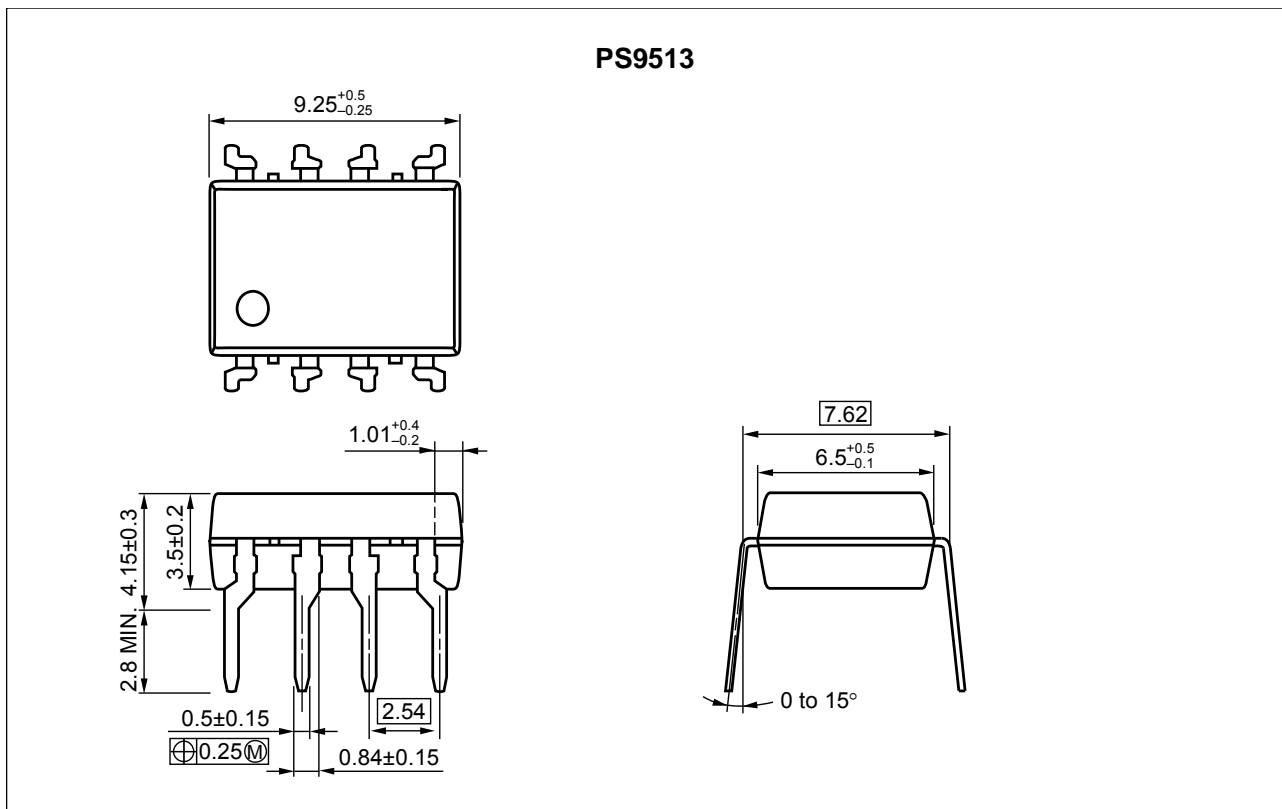

- Lead Bending Type (Gull-wing) For Surface Mount

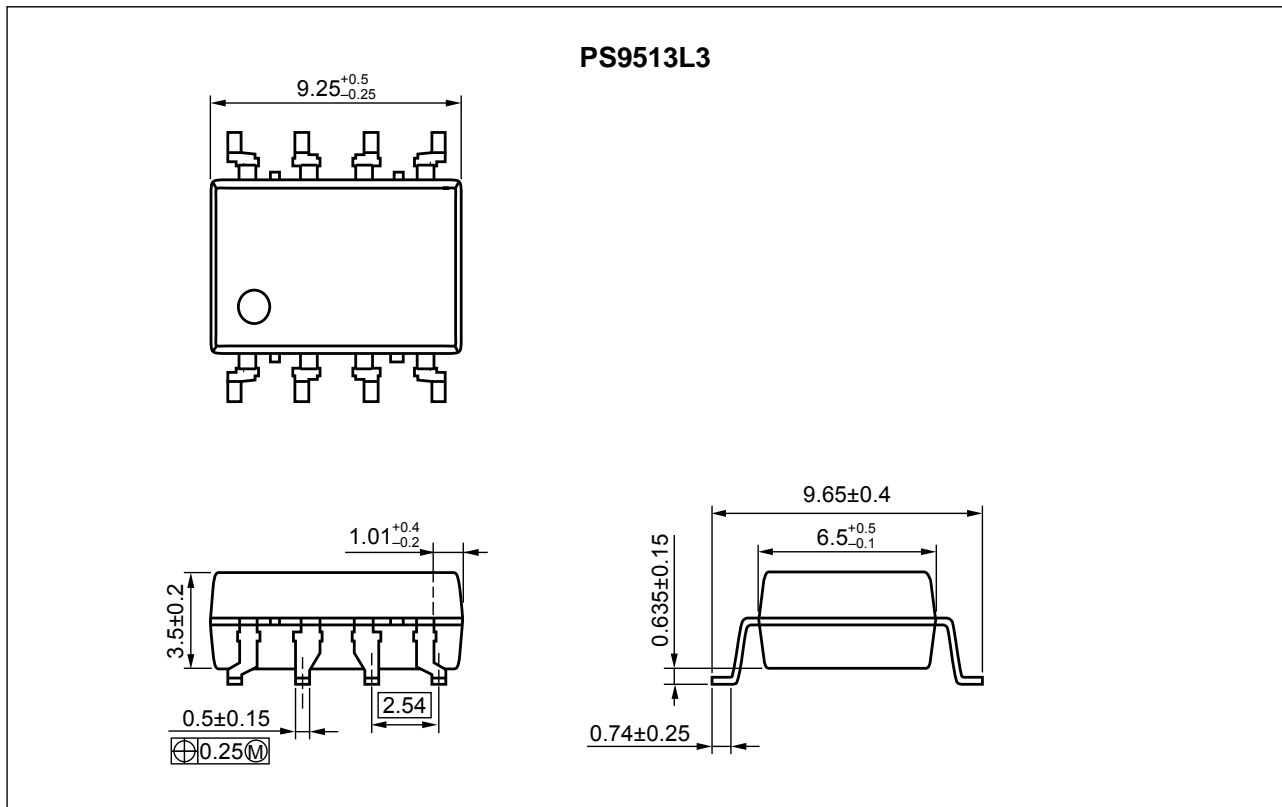

PS9513, PS9513L, PS9513L2, PS9513L3

- Lead Bending Type For Long Creepage Distance

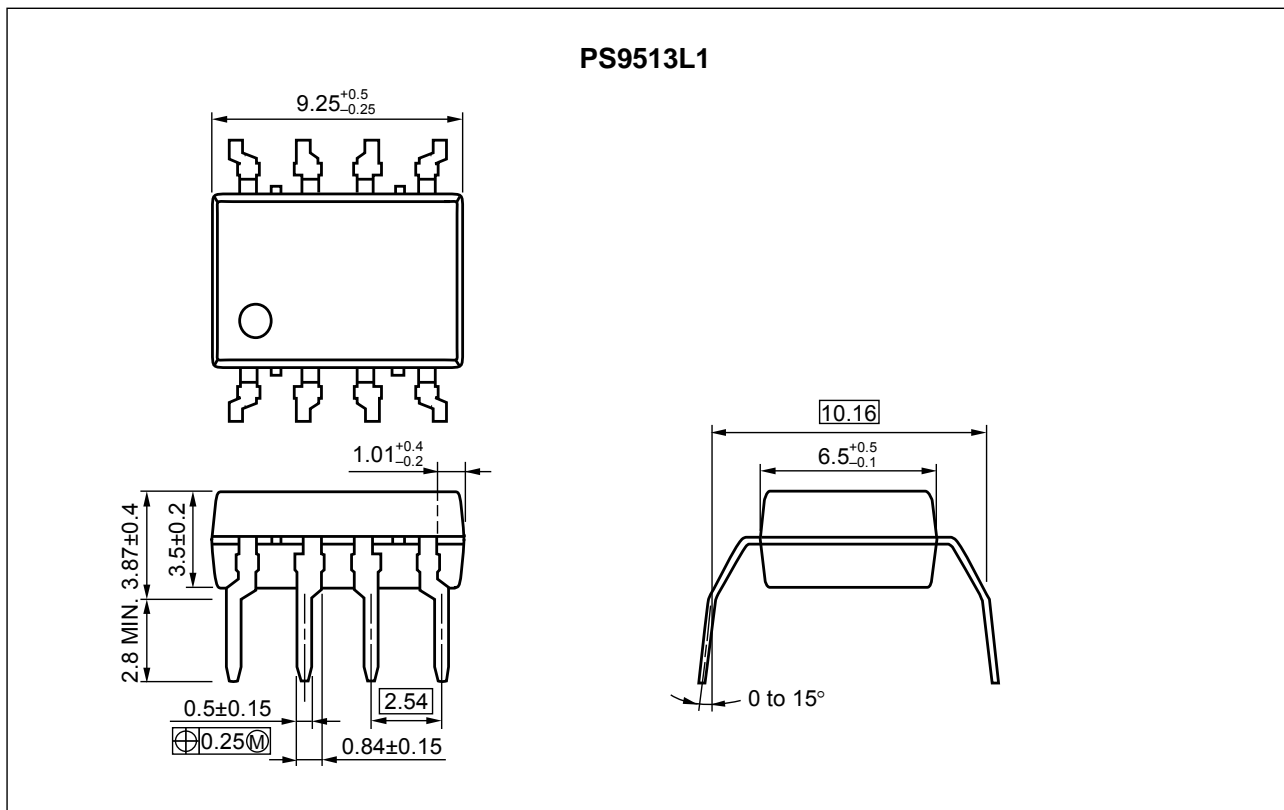

- Lead Bending Type For Long Creepage Distance (Gull-wing) For Surface Mount

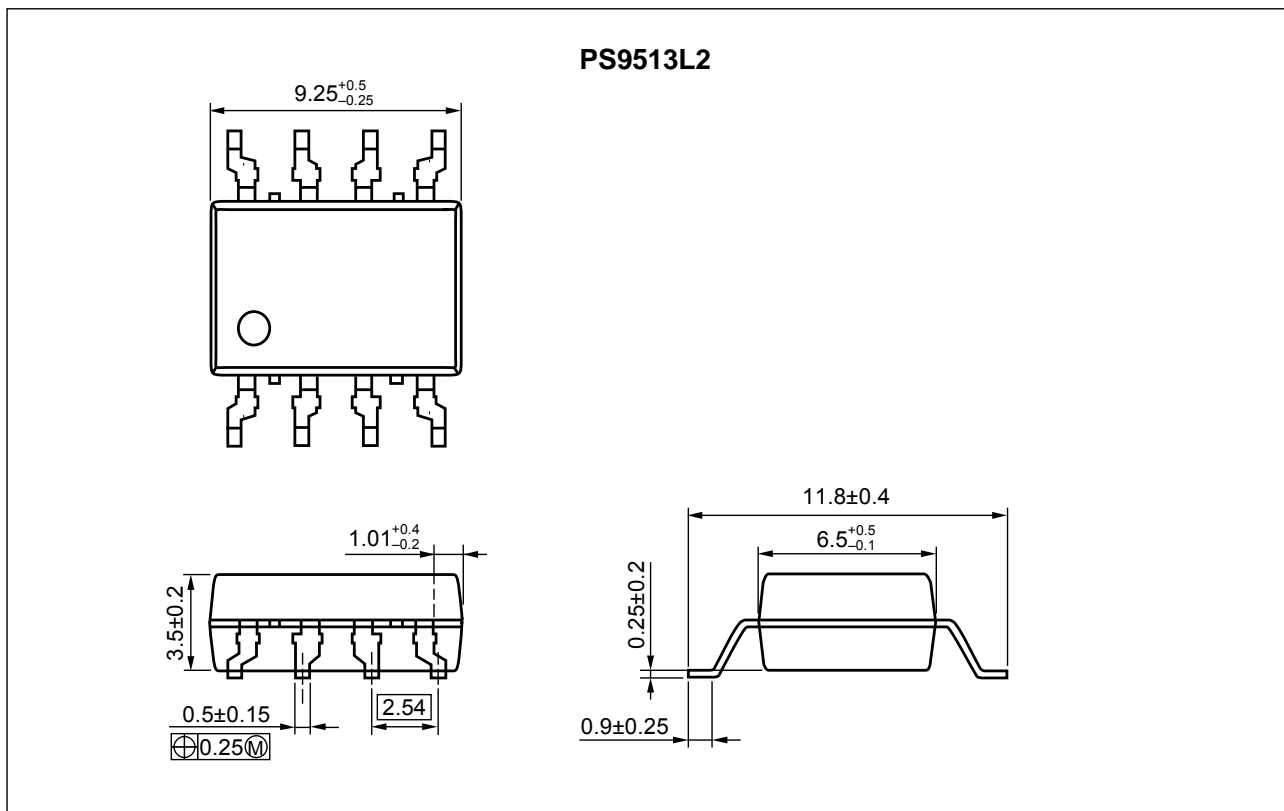

PHOTOCOUPLER CONSTRUCTION

| Parameter | PS9513, PS9513L3 | PS9513L1, PS9513L2 |
|--------------------------------|------------------|--------------------|
| Air Distance (MIN.) | 7 mm | 8 mm |
| Outer Creepage Distance (MIN.) | 7 mm | 8 mm |
| Isolation Distance (MIN.) | 0.4 mm | 0.4 mm |

FUNCTIONAL DIAGRAM

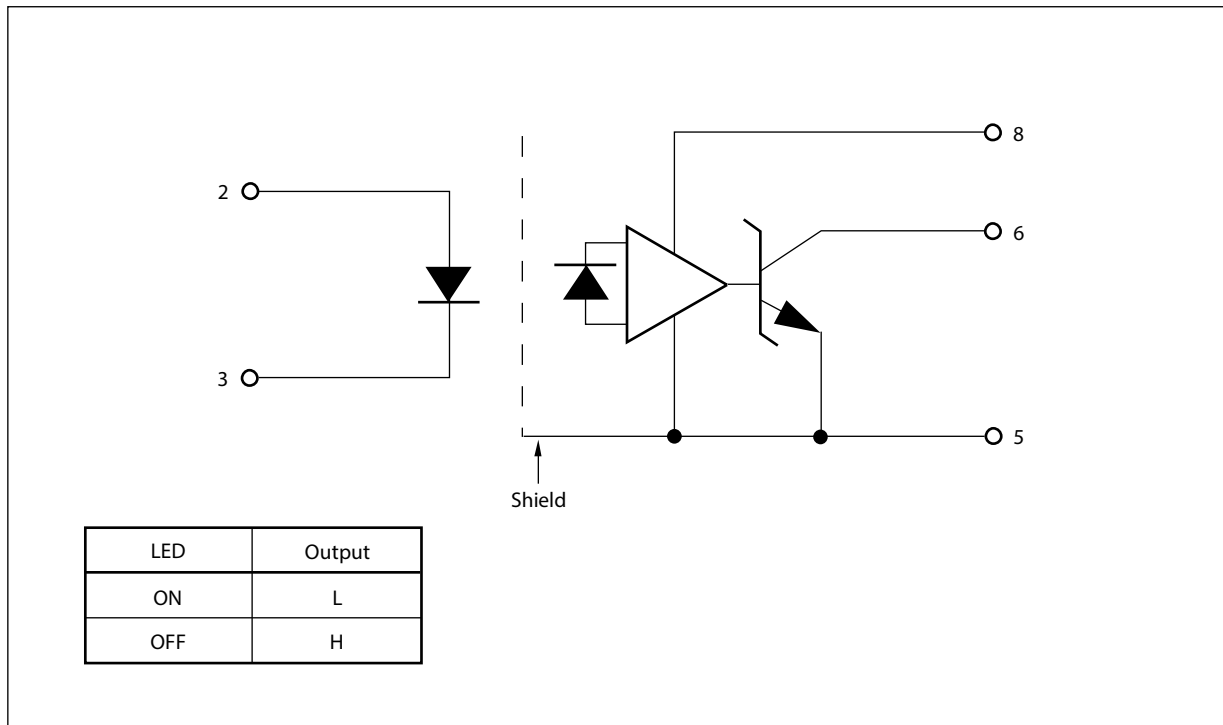

MARKING EXAMPLE

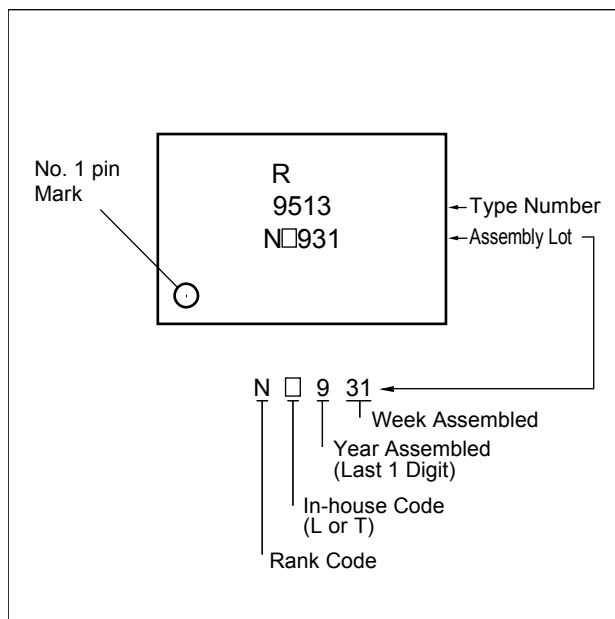

ORDERING INFORMATION

| Part Number | Order Number | Solder Plating Specification | Packing Style | Safety Standard Approval | Application Part Number*1 |
|---------------|------------------|------------------------------|------------------------------|---|---|
| PS9513 | PS9513-AX | Pb-Free (Ni/Pd/Au) | Magazine case 50 pcs | Standard products (UL, CSA, BSI, SEMKO, NEMKO, DEMKO, FIMKO approved) | PS9513 |
| PS9513L1 | PS9513L1-AX | | | | PS9513L1 |
| PS9513L2 | PS9513L2-AX | | | | PS9513L2 |
| PS9513L3 | PS9513L3-AX | | | | PS9513L3 |
| PS9513L2-E3 | PS9513L2-E3-AX | | Embossed Tape 1 000 pcs/reel | approved) | PS9513L2 |
| PS9513L3-E3 | PS9513L3-E3-AX | | | | PS9513L3 |
| PS9513-V | PS9513-V-AX | | Magazine case 50 pcs | | DIN EN60747-5-5 (VDE0884-5):2011- 11 Approved (Option) |
| PS9513L1-V | PS9513L1-V-AX | | | PS9513L1 | |
| PS9513L2-V | PS9513L2-V-AX | | | PS9513L2 | |
| PS9513L3-V | PS9513L3-V-AX | | | PS9513L3 | |
| PS9513L2-V-E3 | PS9513L2-V-E3-AX | | Embossed Tape 1 000 pcs/reel | | PS9513L2 |
| PS9513L3-V-E3 | PS9513L3-V-E3-AX | | | | PS9513L3 |

Notes*: 1. For the application of the Safety Standard, following part number should be used.

PS9513, PS9513L, PS9513L2, PS9513L3**ABSOLUTE MAXIMUM RATINGS (T_A = 25°C, unless otherwise specified)**

| Parameter | | Symbol | Ratings | Unit |
|-------------------------------|----------------------|------------------|-------------|---------|
| Diode | Forward Current *1 | I _F | 25 | mA |
| | Reverse Voltage | V _R | 5.0 | V |
| Detector | Supply Voltage | V _{CC} | -0.5 to +25 | V |
| | Output Voltage | V _O | -0.5 to +25 | V |
| | Output Current | I _O | 15 | mA |
| | Power Dissipation *2 | P _C | 100 | mW |
| Isolation Voltage *3 | | BV | 5 000 | Vr.m.s. |
| Operating Ambient Temperature | | T _A | -40 to +100 | °C |
| Storage Temperature | | T _{stg} | -55 to +125 | °C |

Notes*: 1. Reduced to 0.33 mA/°C at T_A = 70°C or more.

2. Reduced to 2.0 mW/°C at T_A = 70°C or more.

3. AC voltage for 1 minute at T_A = 25°C, RH = 60% between input and output.

Pins 1-4 shorted together, 5-8 shorted together.

RECOMMENDED OPERATING CONDITIONS

| Parameter | Symbol | MIN. | TYP. | MAX. | Unit |
|-----------------|-----------------|------|------|------|------|
| Forward Current | I _F | 10 | | 20 | mA |
| Output Voltage | V _O | 0 | | 20 | V |
| Supply Voltage | V _{CC} | 4.5 | 15 | 20 | V |
| Input Voltage | V _F | 0 | | 0.8 | V |

PS9513, PS9513L, PS9513L2, PS9513L3

ELECTRICAL CHARACTERISTICS ($T_A = -40$ to $+100^\circ\text{C}$, $V_{CC} = 15$ V, unless otherwise specified)

| Parameter | | Symbol | Conditions | MIN. | TYP.*1 | MAX. | Unit |
|-----------|---|---------------------|--|-----------|--------|------|-------------------|
| Diode | Forward Voltage | V_F | $I_F = 10$ mA | 1.3 | 1.65 | 2.1 | V |
| | Reverse Current | I_R | $V_R = 3$ V | | | 200 | μA |
| | Terminal Capacitance | C_t | $V = 0$ V, $f = 1$ MHz, $T_A = 25^\circ\text{C}$ | | 30 | | pF |
| Detector | Low Level Output Voltage | V_{OL} | $I_F = 10$ mA, $I_{OL} = 2.4$ mA | | 0.13 | 0.6 | V |
| | High Level Output Current | I_{OH} | $V_{CC} = 20$ V, $V_F = 0.8$ V | | 1.0 | 50 | μA |
| | High Level Supply Current | I_{CCH} | $V_{CC} = 20$ V, $V_F = 0.8$ V, $V_O = \text{open}$ | | 0.6 | 1.3 | mA |
| | Low Level Supply Current | I_{CCL} | $V_{CC} = 20$ V, $I_F = 10$ mA, $V_O = \text{open}$ | | 0.6 | 1.3 | mA |
| Coupled | Threshold Input Current ($H \rightarrow L$) | I_{FHL} | $V_O = 0.8$ V, $I_O = 0.75$ mA | | 0.86 | 5.0 | mA |
| | Current Transfer Ratio (I_C/I_F) | CTR | $I_F = 10$ mA, $V_O = 0.6$ V | 44 | 110 | | % |
| | Isolation Resistance | R_{I-O} | $V_{I-O} = 1$ kV _{DC} , $R_H = 40$ to 60% , $T_A = 25^\circ\text{C}$ | 10^{11} | | | Ω |
| | Isolation Capacitance | C_{I-O} | $V = 0$ V, $f = 1$ MHz, $T_A = 25^\circ\text{C}$ | | 0.7 | | pF |
| | Propagation Delay Time ($H \rightarrow L$)*2 | t_{PHL} | $I_F = 10$ mA, $R_L = 20$ k Ω , $C_L = 100$ pF, $V_{THHL} = 1.5$ V, $V_{THLH} = 2.0$ V | | 250 | 500 | ns |
| | Propagation Delay Time ($L \rightarrow H$)*2 | t_{PLH} | | | 520 | 750 | |
| | Maximum Propagation Delays | $t_{PLH}-t_{PHL}$ | | -200 | 270 | 650 | |
| | Pulse Width Distortion (PWD)*2 | $ t_{PHL}-t_{PLH} $ | | | 270 | 650 | |
| | Common Mode Transient Immunity at High Level Output*3 | CM_H | $T_A = 25^\circ\text{C}$, $I_F = 0$ mA, $V_O > 3.0$ V, $V_{CM} = 1.5$ kV, $R_L = 20$ k Ω , $C_L = 100$ pF | 15 | | | kV/ μs |
| | Common Mode Transient Immunity at Low Level Output*3 | CM_L | $T_A = 25^\circ\text{C}$, $I_F = 10$ mA, $V_O < 1.0$ V, $V_{CM} = 1.5$ kV, $R_L = 20$ k Ω , $C_L = 100$ pF | 15 | | | kV/ μs |

PS9513, PS9513L, PS9513L2, PS9513L3

Notes*: 1. Typical values at $T_A = 25^\circ\text{C}$.

2. Test circuit for propagation delay time

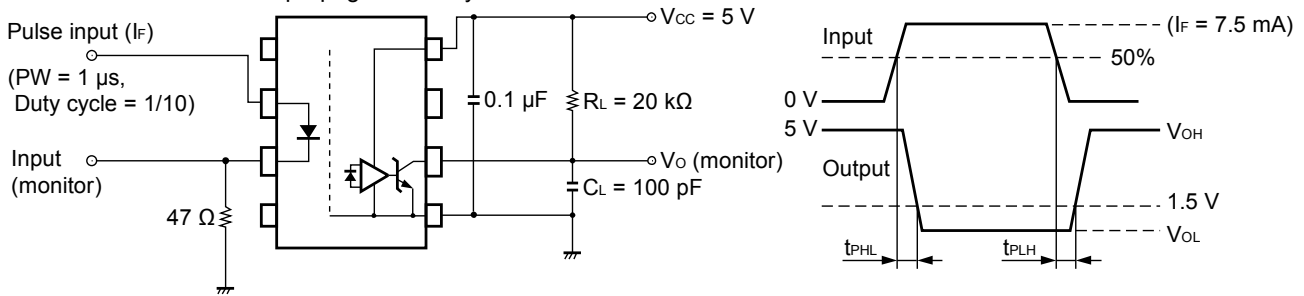

Remark C_L includes probe and stray wiring capacitance.

3. Test circuit for common mode transient immunity

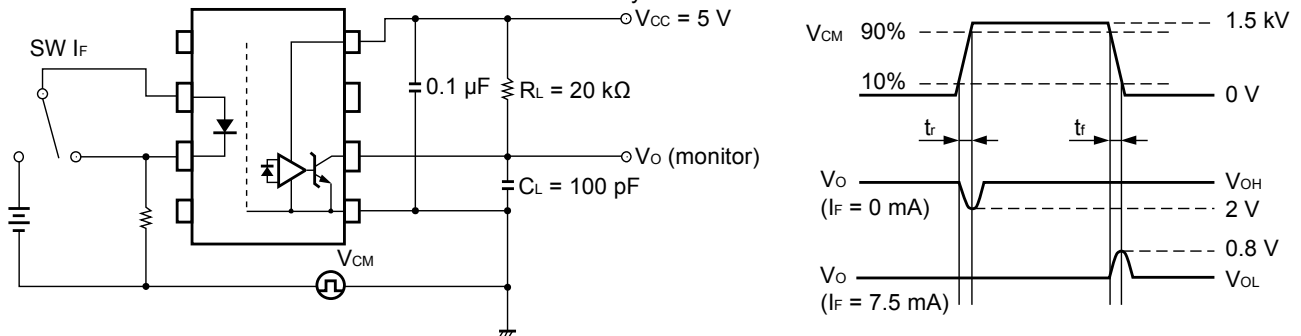

Remark C_L includes probe and stray wiring capacitance.

USAGE CAUTIONS

1. This product is weak for static electricity by designed with high-speed integrated circuit so protect against static electricity when handling.
2. By-pass capacitor of more than $0.1\ \mu\text{F}$ is used between V_{CC} and GND near device. Also, ensure that the distance between the leads of the photocopier and capacitor is no more than 10 mm.
3. Pins 1, 4 (which is an NC*1 pin) can either be connected directly to the GND pin on the LED side or left open. Also, Pin 7 (which is an NC*1 pin) can either be connected directly to the GND pin on the detector side or left open.

Unconnected pins should not be used as a bypass for signals or for any other similar purpose because this may degrade the internal noise environment of the device.

*1 NC: Non-Connection (No Connection)

4. Avoid storage at a high temperature and high humidity.

TYPICAL CHARACTERISTICS (T_A = 25°C unless otherwise specified)

SUPPLY CURRENT vs. AMBIENT TEMPERATURE

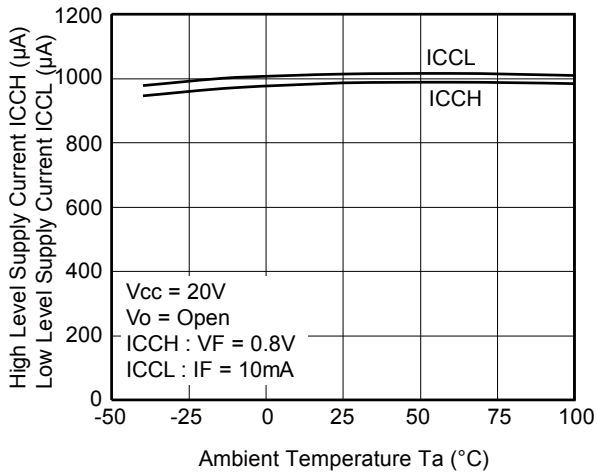

THRESHOLD INPUT CURRENT vs. AMBIENT TEMPERATURE

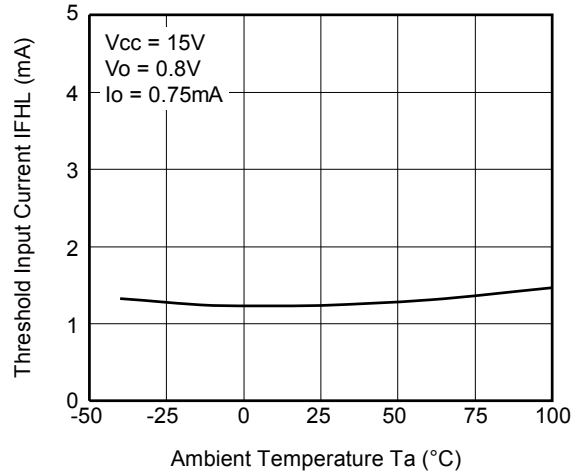

LOW LEVEL OUTPUT VOLTAGE vs. AMBIENT TEMPERATURE

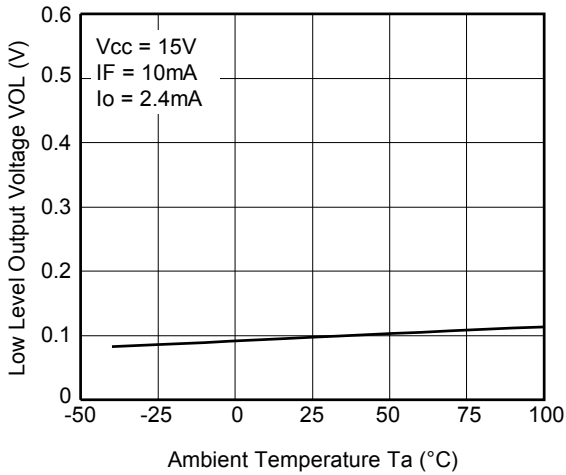

OUTPUT CURRENT vs. FORWARD CURRENT

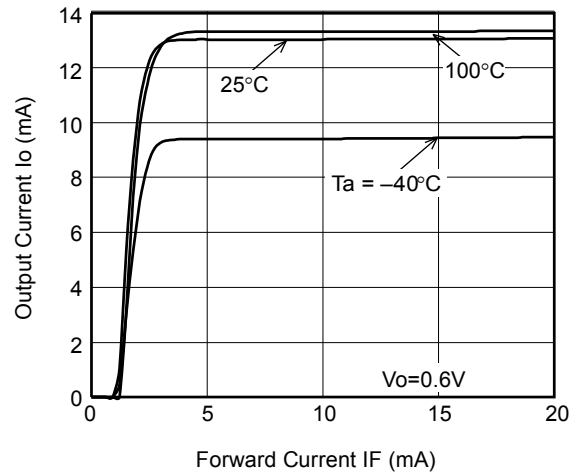

OUTPUT CURRENT vs. AMBIENT TEMPERATURE

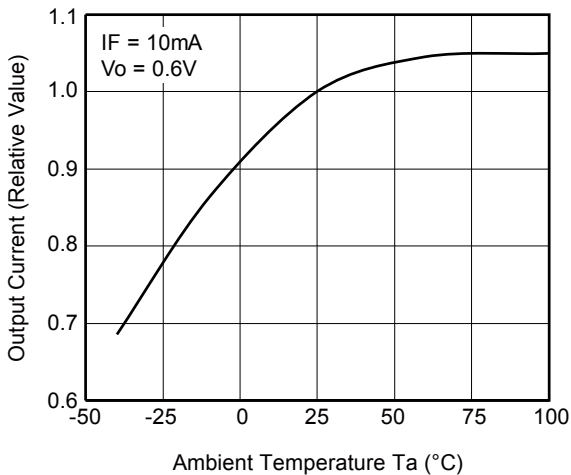

PROPAGATION DELAY TIME, MAXIMUM PROPAGATION DELAYS vs. FORWARD CURRENT

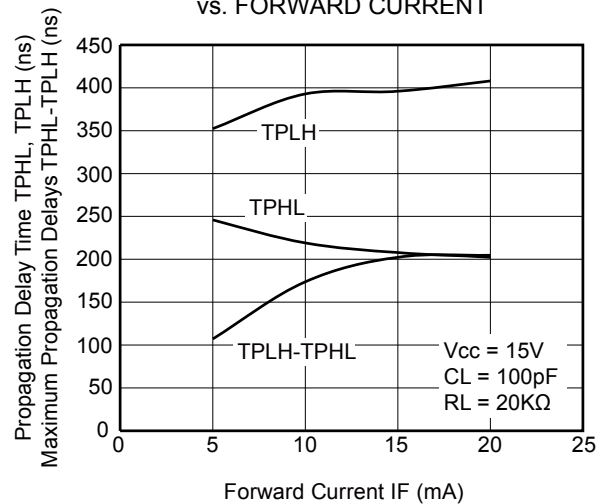

PS9513, PS9513L, PS9513L2, PS9513L3

PROPAGATION DELAY TIME,
MAXIMUM PROPAGATION DELAYS
vs. SUPPLY VOLTAGE

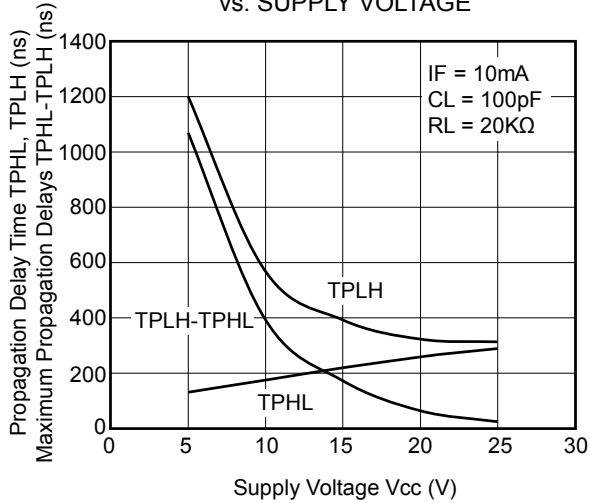

PROPAGATION DELAY TIME,
PULSE WIDTH DISTORTION
vs. AMBIENT TEMPERATURE

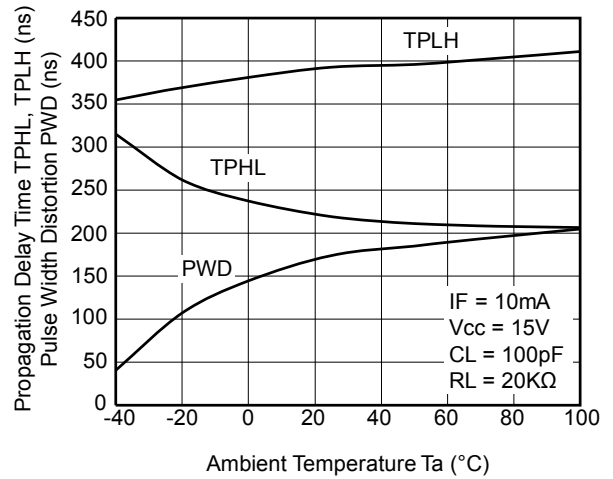

PROPAGATION DELAY TIME
vs. LOAD CAPACITANCE

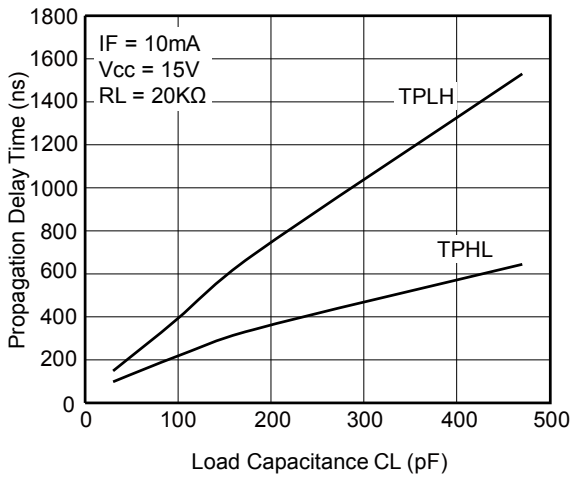

PROPAGATION DELAY TIME,
MAXIMUM PROPAGATION DELAYS
vs. LOAD RESISTANCE

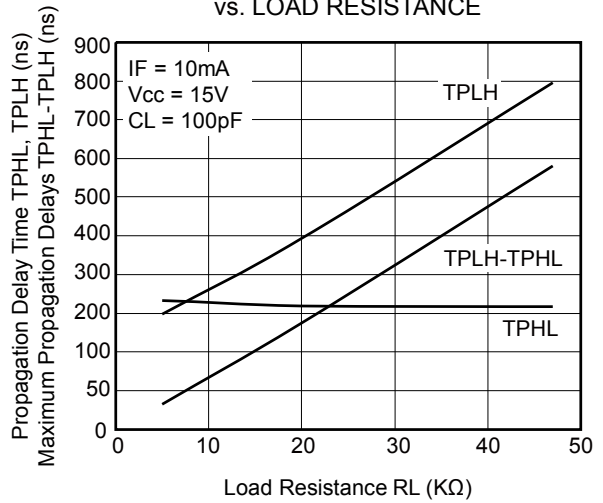

PROPAGATION DELAY TIME,
MAXIMUM PROPAGATION DELAYS
vs. LOAD RESISTANCE

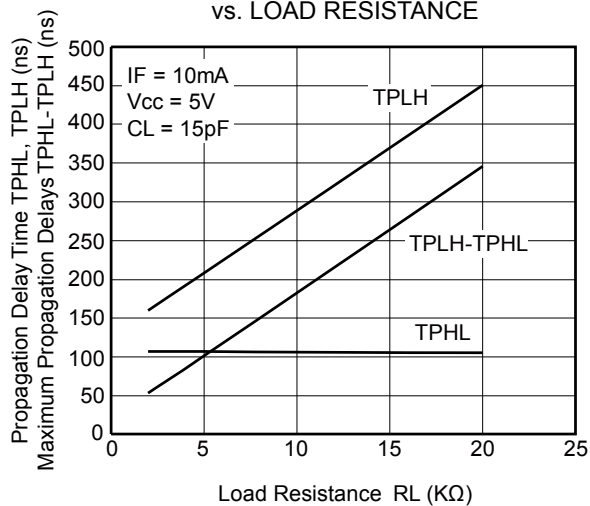

TAPING SPECIFICATIONS (UNIT: mm)

Outline and Dimensions (Tape)

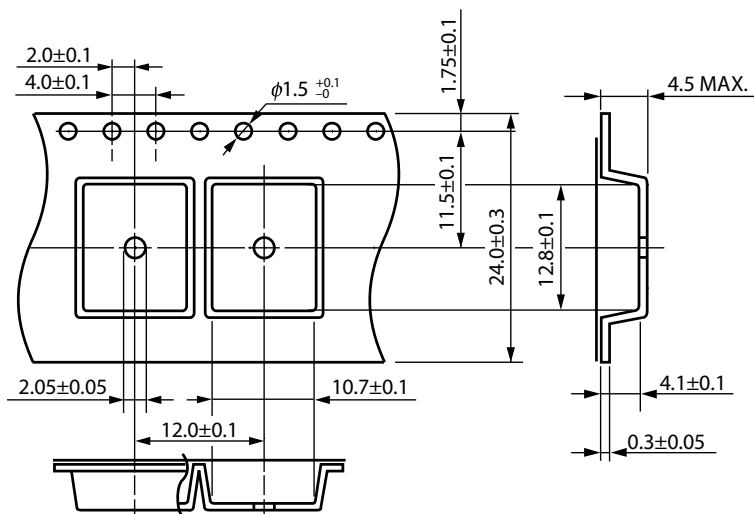

Tape Direction

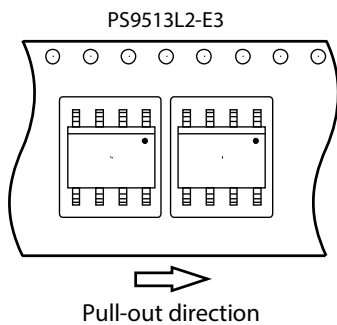

Outline and Dimensions (Reel)

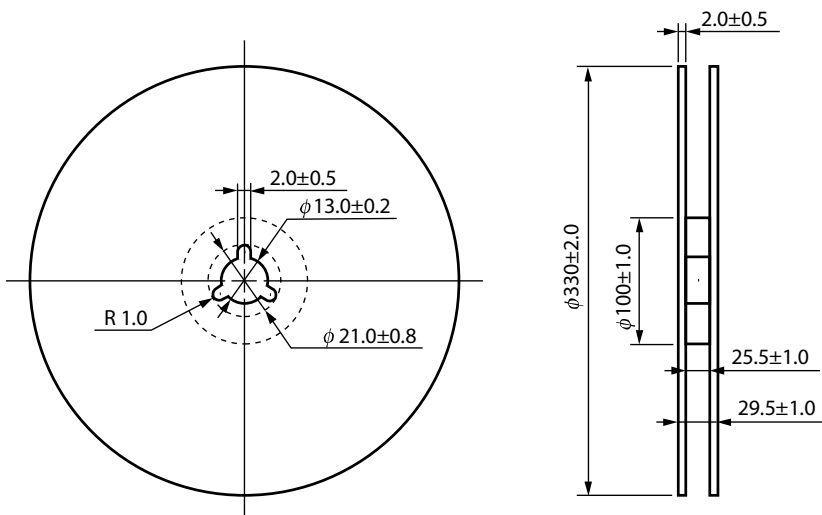

Packing: 1 000 pcs/reel

Outline and Dimensions (Tape)

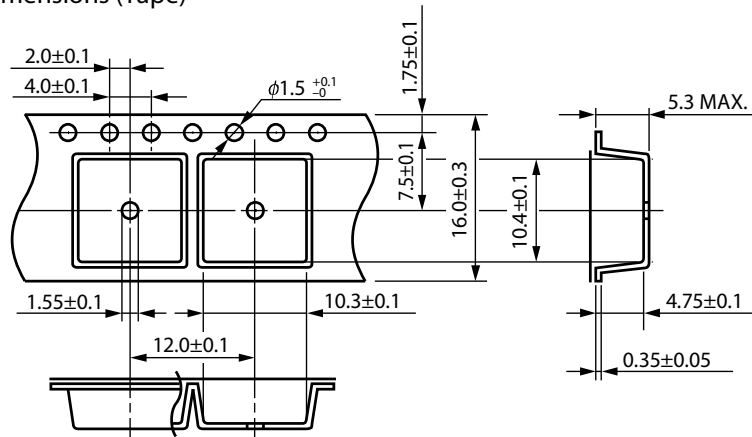

Tape Direction

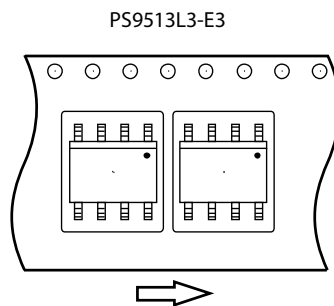

Outline and Dimensions (Reel)

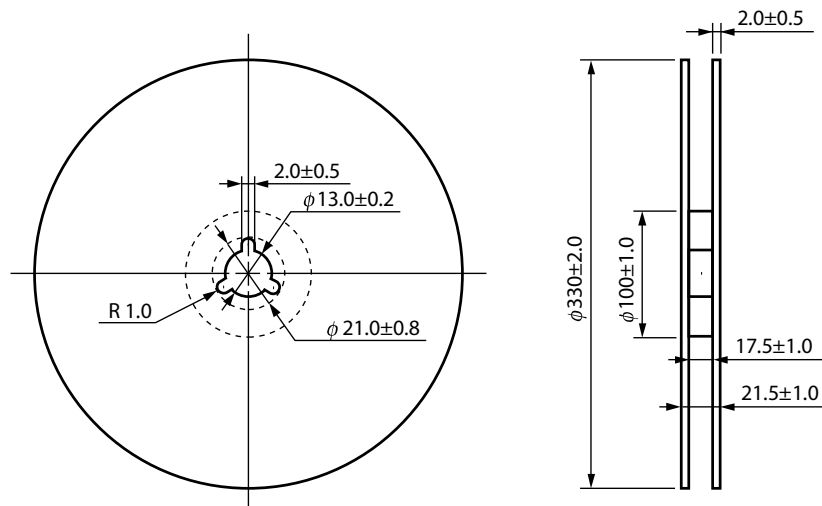

Packing: 1 000 pcs/reel

RECOMMENDED MOUNT PAD DIMENSIONS (UNIT: mm)

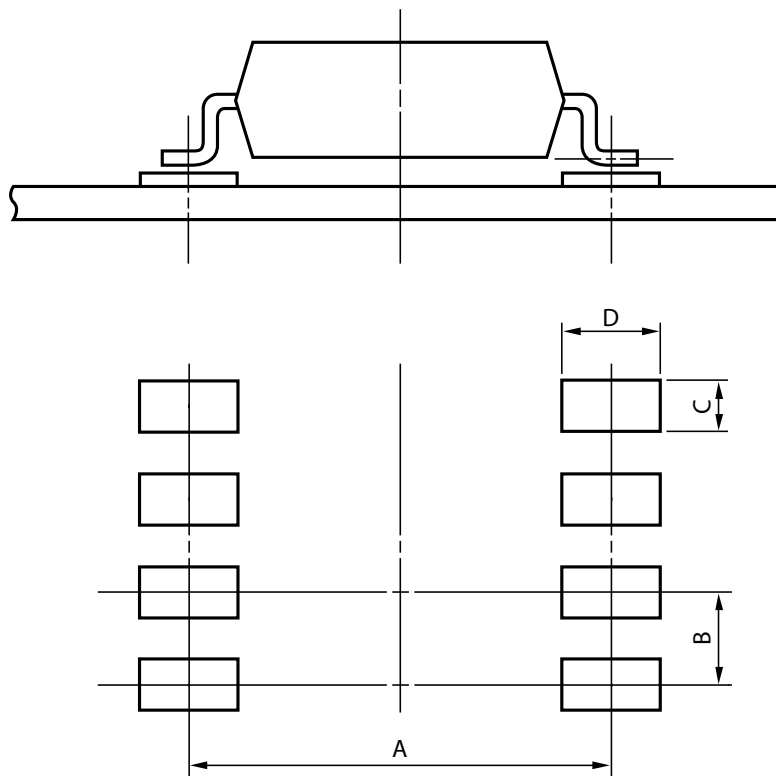

| Part Number | Lead Bending | A | B | C | D |
|-------------|---|------|------|-----|-----|
| PS9513L2 | lead bending type (Gull-wing) for long creepage distance (surface mount) | 10.2 | 2.54 | 1.7 | 2.2 |
| PS9513L3 | lead bending type (Gull-wing) for surface mount | 8.2 | 2.54 | 1.7 | 2.2 |

NOTES ON HANDLING

1. Recommended soldering conditions

(1) Infrared reflow soldering

- Peak reflow temperature 260°C or below (package surface temperature)
- Time of peak reflow temperature 10 seconds or less
- Time of temperature higher than 220°C 60 seconds or less
- Time to preheat temperature from 120 to 180°C 120±30 s
- Number of reflows Three
- Flux Rosin flux containing small amount of chlorine (The flux with a maximum chlorine content of 0.2 Wt% is recommended.)

Recommended Temperature Profile of Infrared Reflow

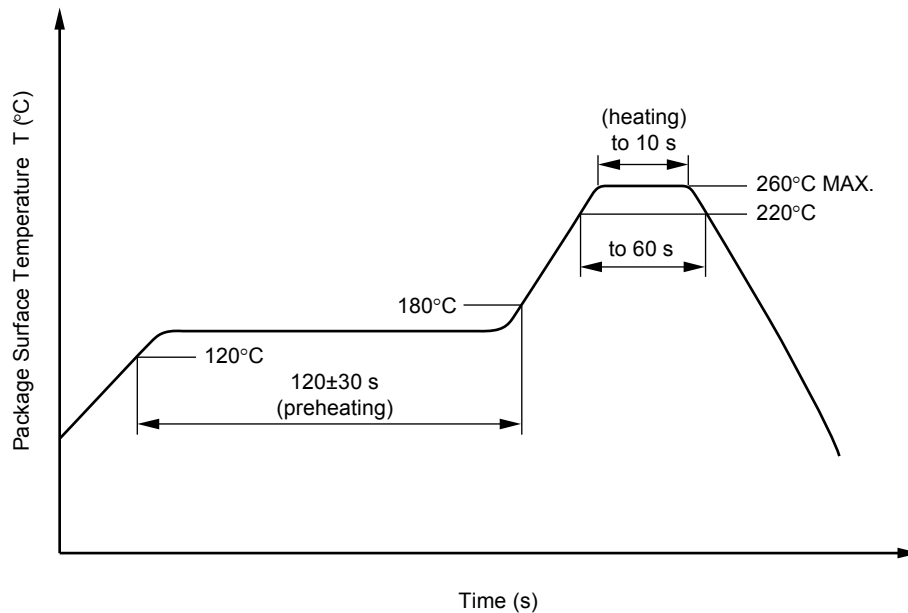

(2) Wave soldering

- Temperature 260°C or below (molten solder temperature)
- Time 10 seconds or less
- Preheating conditions 120°C or below (package surface temperature)
- Number of times One (Allowed to be dipped in solder including plastic mold portion.)
- Flux Rosin flux containing small amount of chlorine (The flux with a maximum chlorine content of 0.2 Wt% is recommended.)

(3) Soldering by Soldering Iron

- Peak Temperature (lead part temperature) 350°C or below
- Time (each pins) 3 seconds or less
- Flux Rosin flux containing small amount of chlorine (The flux with a maximum chlorine content of 0.2 Wt% is recommended.)

(a) Soldering of leads should be made at the point 1.5 to 2.0 mm from the root of the lead

(b) Please be sure that the temperature of the package would not be heated over 100°C

(4) Cautions

- Fluxes

Avoid removing the residual flux with freon-based and chlorine-based cleaning solvent.

2. Cautions regarding noise

Be aware that when voltage is applied suddenly between the photocoupler's input and output or between V_{CC}-GND at startup, the output transistor may enter the on state, even if the voltage is within the absolute maximum ratings.

SPECIFICATION OF VDE MARKS LICENSE DOCUMENT

| Parameter | Symbol | Speck | Unit |
|--|------------|-------------|--------------------|
| Climatic test class (IEC 60068-1/DIN EN 60068-1) | | 40/100/21 | |
| Dielectric strength maximum operating isolation voltage | U_{IORM} | 1 130 | V_{peak} |
| Test voltage (partial discharge test, procedure a for type test and random test) $U_{pr} = 1.6 \times U_{IORM}, P_d < 5 \text{ pC}$ | U_{pr} | 1 808 | V_{peak} |
| Test voltage (partial discharge test, procedure b for all devices) $U_{pr} = 1.875 \times U_{IORM}, P_d < 5 \text{ pC}$ | U_{pr} | 2 119 | V_{peak} |
| Highest permissible overvoltage | U_{TR} | 8 000 | V_{peak} |
| Degree of pollution (DIN EN 60664-1 VDE 0110 Part 1) | | 2 | |
| Comparative tracking index (IEC 60112/DIN EN 60112 (VDE 0303 Part 11)) | CTI | 175 | |
| Material group (DIN EN 60664-1 VDE 0110 Part 1) | | III a | |
| Storage temperature range | T_{stg} | -55 to +125 | $^{\circ}\text{C}$ |
| Operating temperature range | T_A | -40 to +100 | $^{\circ}\text{C}$ |
| Isolation resistance, minimum value $V_{IO} = 500 \text{ V dc at } T_A = 25^{\circ}\text{C}$ | Ris MIN. | 10^{12} | Ω |
| $V_{IO} = 500 \text{ V dc at } T_A \text{ MAX. at least } 100^{\circ}\text{C}$ | Ris MIN. | 10^{11} | Ω |
| Safety maximum ratings (maximum permissible in case of fault, see thermal derating curve) | | | |
| Package temperature | T_{si} | 175 | $^{\circ}\text{C}$ |
| Current (input current I_F , $P_{si} = 0$) | I_{si} | 400 | mA |
| Power (output or total power dissipation) | P_{si} | 700 | mW |
| Isolation resistance $V_{IO} = 500 \text{ V dc at } T_A = T_{si}$ | Ris MIN. | 10^9 | Ω |

Caution

GaAs Products

This product uses gallium arsenide (GaAs).

GaAs vapor and powder are hazardous to human health if inhaled or ingested, so please observe the following points.

- Follow related laws and ordinances when disposing of the product. If there are no applicable laws and/or ordinances, dispose of the product as recommended below.
 1. Commission a disposal company able to (with a license to) collect, transport and dispose of materials that contain arsenic and other such industrial waste materials.
 2. Exclude the product from general industrial waste and household garbage, and ensure that the product is controlled (as industrial waste subject to special control) up until final disposal.
- Do not burn, destroy, cut, crush, or chemically dissolve the product.
- Do not lick the product or in any way allow it to enter the mouth.

NOTICE

1. Descriptions of circuits, software and other related information in this document are provided only to illustrate the operation of semiconductor products and application examples. You are fully responsible for the incorporation of these circuits, software, and information in the design of your equipment. California Eastern Laboratories and Renesas Electronics assumes no responsibility for any losses incurred by you or third parties arising from the use of these circuits, software, or information.
2. California Eastern Laboratories has used reasonable care in preparing the information included in this document, but California Eastern Laboratories does not warrant that such information is error free. California Eastern Laboratories and Renesas Electronics assumes no liability whatsoever for any damages incurred by you resulting from errors in or omissions from the information included herein.
3. California Eastern Laboratories and Renesas Electronics do not assume any liability for infringement of patents, copyrights, or other intellectual property rights of third parties by or arising from the use of Renesas Electronics products or technical information described in this document. No license, express, implied or otherwise, is granted hereby under any patents, copyrights or other intellectual property rights of California Eastern Laboratories or Renesas Electronics or others.
4. You should not alter, modify, copy, or otherwise misappropriate any Renesas Electronics product, whether in whole or in part. California Eastern Laboratories and Renesas Electronics assume no responsibility for any losses incurred by you or third parties arising from such alteration, modification, copy or otherwise misappropriation of Renesas Electronics product.
5. Renesas Electronics products are classified according to the following two quality grades: "Standard" and "High Quality". The recommended applications for each Renesas Electronics product depends on the product's quality grade, as indicated below. "Standard": Computers; office equipment; communications equipment; test and measurement equipment; audio and visual equipment; home electronic appliances; machine tools; personal electronic equipment; and industrial robots etc. "High Quality": Transportation equipment (automobiles, trains, ships, etc.); traffic control systems; anti-disaster systems; anti-crime systems; and safety equipment etc. Renesas Electronics products are neither intended nor authorized for use in products or systems that may pose a direct threat to human life or bodily injury (artificial life support devices or systems, surgical implantations etc.), or may cause serious property damages (nuclear reactor control systems, military equipment etc.). You must check the quality grade of each Renesas Electronics product before using it in a particular application. You may not use any Renesas Electronics product for any application for which it is not intended. California Eastern Laboratories and Renesas Electronics shall not be in any way liable for any damages or losses incurred by you or third parties arising from the use of any Renesas Electronics product for which the product is not intended by California Eastern Laboratories or Renesas Electronics.
6. You should use the Renesas Electronics products described in this document within the range specified by California Eastern Laboratories, especially with respect to the maximum rating, operating supply voltage range, movement power voltage range, heat radiation characteristics, installation and other product characteristics. California Eastern Laboratories shall have no liability for malfunctions or damages arising out of the use of Renesas Electronics products beyond such specified ranges.
7. Although Renesas Electronics endeavors to improve the quality and reliability of its products, semiconductor products have specific characteristics such as the occurrence of failure at a certain rate and malfunctions under certain use conditions. Further, Renesas Electronics products are not subject to radiation resistance design. Please be sure to implement safety measures to guard them against the possibility of physical injury, and injury or damage caused by fire in the event of the failure of a Renesas Electronics product, such as safety design for hardware and software including but not limited to redundancy, fire control and malfunction prevention, appropriate treatment for aging degradation or any other appropriate measures. Because the evaluation of microcomputer software alone is very difficult, please evaluate the safety of the final products or systems manufactured by you.
8. Please contact a California Eastern Laboratories sales office for details as to environmental matters such as the environmental compatibility of each Renesas Electronics product. Please use Renesas Electronics products in compliance with all applicable laws and regulations that regulate the inclusion or use of controlled substances, including without limitation, the EU RoHS Directive. California Eastern Laboratories and Renesas Electronics assume no liability for damages or losses occurring as a result of your noncompliance with applicable laws and regulations.
9. Renesas Electronics products and technology may not be used for or incorporated into any products or systems whose manufacture, use, or sale is prohibited under any applicable domestic or foreign laws or regulations. You should not use Renesas Electronics products or technology described in this document for any purpose relating to military applications or use by the military, including but not limited to the development of weapons of mass destruction. When exporting the Renesas Electronics products or technology described in this document, you should comply with the applicable export control laws and regulations and follow the procedures required by such laws and regulations.
10. It is the responsibility of the buyer or distributor of California Eastern Laboratories, who distributes, disposes of, or otherwise places the Renesas Electronics product with a third party, to notify such third party in advance of the contents and conditions set forth in this document, California Eastern Laboratories and Renesas Electronics assume no responsibility for any losses incurred by you or third parties as a result of unauthorized use of Renesas Electronics products.
11. This document may not be reproduced or duplicated in any form, in whole or in part, without prior written consent of California Eastern Laboratories.
12. Please contact a California Eastern Laboratories sales office if you have any questions regarding the information contained in this document or Renesas Electronics products, or if you have any other inquiries.

NOTE 1: "Renesas Electronics" as used in this document means Renesas Electronics Corporation and also includes its majority-owned subsidiaries.

NOTE 2: "Renesas Electronics product(s)" means any product developed or manufactured by or for Renesas Electronics.



NOTE 3: Products and product information are subject to change without notice.

CEL Headquarters • 4590 Patrick Henry Drive, Santa Clara, CA 95054 • Phone (408) 919-2500 • www.cel.com

For a complete list of sales offices, representatives and distributors,
Please visit our website: www.cel.com/contactus

Looking for pricing, stock, or lifecycle information?

Click below to explore more details on WIN SOURCE:

-  [View PS9513L3-E3-AX on WIN SOURCE](#)
-  [CEL Information](#)

Optimize Your Supply Chain with WIN SOURCE Solutions

-  Global Sourcing Solution
-  Obsolete Management
-  Cost Control Management
-  Shortage Management
-  Alternative Solution
-  Excess Inventory Management