

Voltage Detector IC Series

CMOS Over Voltage Detector IC

BD71L4L-1 series

General Descriptions

ROHM's BD71L4L-1 series is highly accurate and low current Over Voltage Detector IC. It is an N-Channel Open-Drain output type with detection voltage of 4.05V and hysteresis voltage of 30mV. It is most suitable for monitoring the charge of a lithium-ion battery.

Features

- High Accuracy Detection Voltage
- Low Current Consumption
- N-Channel Open Drain Output
- Wide Operating Temperature Range
- Very Small and Low Height Package
- Package SSOP5 is similar to SOT-23-5 (JEDEC)

Key Specifications

- Detection Voltage: 4.05V (Typ.)
- High Accuracy Detection Voltage: ±0.8%
- Ultra-Low Current Consumption: 0.8μA (Typ.)
- Operating Temperature Range: -40°C to +85°C

Package

- SSOP5: W(typ) x D(typ) x H(max)
2.90mm x 2.80mm x 1.25mm
- HVSO5: 1.60mm x 1.60mm x 0.60mm

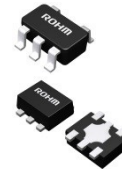

Applications

- All electronics equipment with lithium-ion battery
- All electronics equipment that needs over-voltage protection

Typical Application Circuit

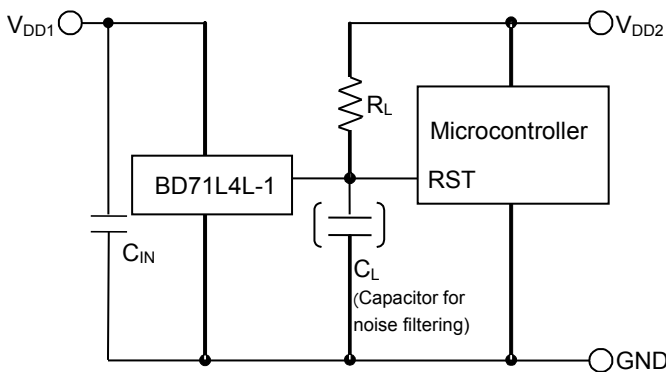

Connection Diagram
SSOP5

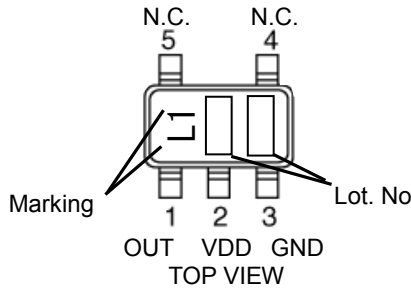

HVSOF5

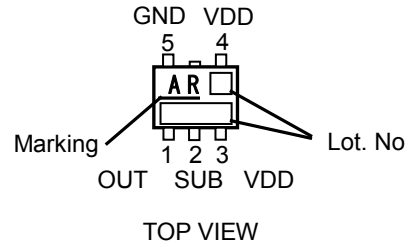

Pin Descriptions

SSOP5		
PIN No.	Symbol	Function
1	OUT	Output pin
2	VDD	Power Supply Voltage
3	GND	GND
4	N.C.	No connection pin
5	N.C.	No connection pin

N.C. pin is electrically open and can be connected to either VDD or GND.

HVSOF5		
PIN No.	Symbol	Function
1	OUT	Output pin
2	SUB *	Substrate
3	VDD *	Power Supply Voltage
4	VDD *	Power Supply Voltage
5	GND	GND

* The SUB pin (pin no. 2) and VDD pins (pin no. 3 and 4) must be wired together.

Ordering Information

B D x x x x x x					-	1 T R			
Part Number	Function 71 : Over Voltage Detector	Output logic L : Active Low	Detection Voltage Value 4L : 4.05V	Package G : SSOP5 HFV : HVSOF5		Packaging and forming specification Embossed tape and reel TR : The pin number 1 is the upper right : SSOP5 : HVSOF5			

Absolute Maximum Ratings

Parameter		Symbol	Limits	Unit
Power Supply Voltage		V_{DD-GND}	-0.3 to +7	V
Output Voltage	N-Channel Open Drain Output	V_{OUT}	GND-0.3 to +7	V
Output Current		I_o	70	mA
Power Dissipation	SSOP5 *1*3	Pd	0.54	W
	HVSOF5 *2*3		0.53	
Operating Temperature		Topr	-40 to +85	°C
Ambient Storage Temperature		Tstg	-55 to +125	°C

*1 Reduced by 0.0054W/°C when used over 25°C.

*2 Reduced by 0.0053W/°C when used over 25°C.

*3 When mounted on ROHM standard circuit board (70mm×70mm×1.6mm, glass epoxy board).

Caution: Operating the IC over the absolute maximum ratings may damage the IC. The damage can either be a short circuit between pins or an open circuit between pins and the internal circuitry. Therefore, it is important to consider circuit protection measures, such as adding a fuse, in case the IC is operated over the absolute maximum ratings.

Electrical Characteristics (Unless Otherwise Specified, Ta=0°C to 60°C, VDD=1.2V to 6.0V)

Parameter	Symbol	Conditions	Limit			Unit	
			Min	Typ	Max		
Detection Voltage	V_{DET}	$R_L=470k\Omega$ $V_{DD}=L \rightarrow H$	Ta=25°C	4.034	4.05	4.066	V
			Ta =0°C to 60°C	4.018	-	4.083	
Hysteresis Voltage	ΔV_{DET}	$V_{DD}=L \rightarrow H \rightarrow L, R_L=470k\Omega$	-	30	40	mV	
Output Delay Time "L→H"	t_{PLH}	$R_L=100k\Omega, C_L=100pF$ $V_{OUT}=GND \rightarrow 50\%$ *4	-	-	100	µs	
Output Delay Time "H→L"	t_{PHL}	$R_L=100k\Omega, C_L=100pF$ $V_{OUT}=V_{DD} \rightarrow 50\%$ *5	-	-	100	µs	
Supply Current 1	I_{DD1}	$V_{DD}=V_{DET} + 0.2V$	-	0.60	2.40	µA	
Supply Current 2	I_{DD2}	$V_{DD}=V_{DET} - 0.2V$	-	0.70	2.80	µA	
Operating Voltage Range	V_{OPL}	$V_{OUT} \geq 0.8V, R_L=470k\Omega$	1.20	-	-	V	
'Low' Output Voltage(Nch)	V_{OL}	$V_{DD}=V_{DET} + 0.2V, I_{SINK}=4.0mA$	-	-	0.3	V	
Output Leak Current	I_{LEAK}	$V_{DD}=V_{DS}=3.8V$	-	-	1.0	uA	

V_{DET} :Standard Detection Voltage(4.05V)

R_L : Pull-up Resistor between VOUT and VDD.

C_L : Capacitor to be connected between VOUT and GND.

Design Guarantee. (Outgoing inspection is not done on all products.)

*4 $t_{PLH}: V_{DD} = (V_{DET} \text{ typ.} + 0.5V)$ to $(V_{DET} \text{ typ.} - 0.5V)$

*5 $t_{PHL}: V_{DD} = (V_{DET} \text{ typ} - 0.5V)$ to $(V_{DET} \text{ typ.} + 0.5V)$

Block Diagram

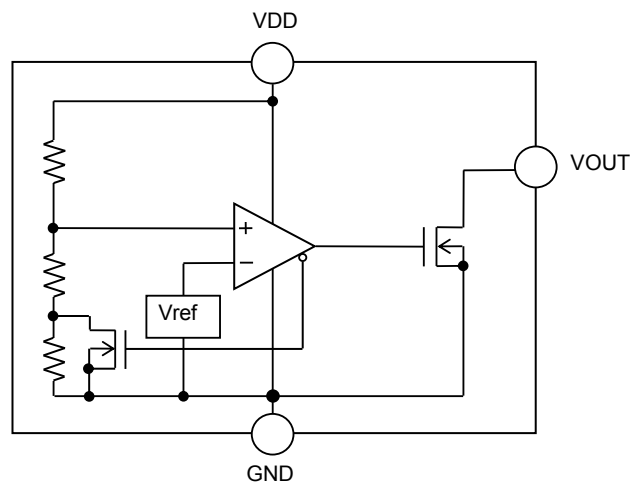

Figure 1. BD71L4L-1

Typical Performance Curves

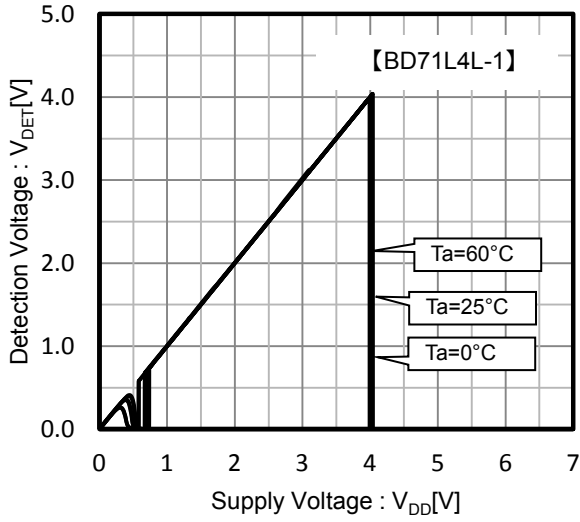

Figure 2. Detection Voltage

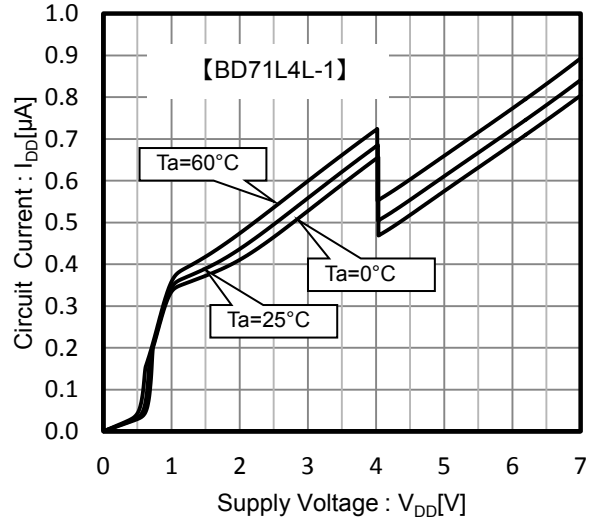

Figure 3. Circuit Current

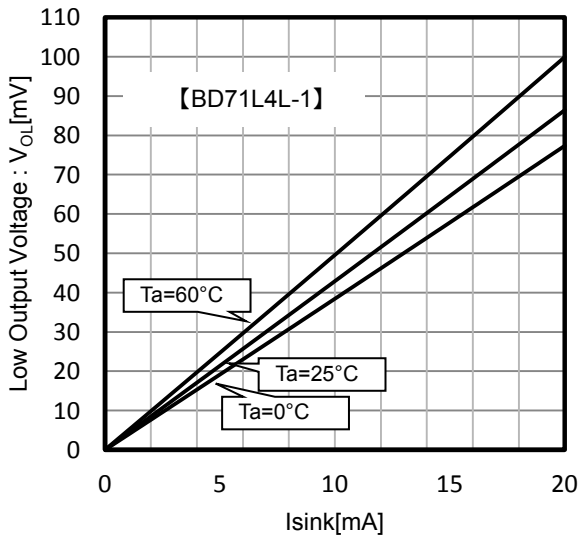

Figure 4. Low Output Voltage

$V_{DD}=4.0\text{V}$

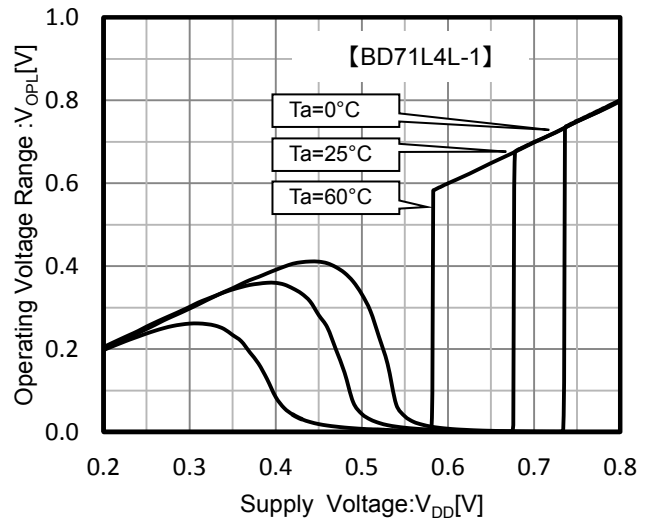

Figure 5. Operating Voltage Range

Typical Performance Curves – continued

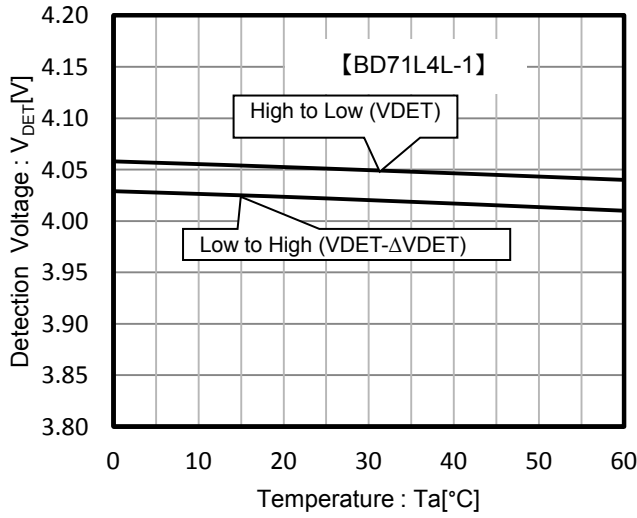

Figure 6. Detection Voltage vs. Temperature

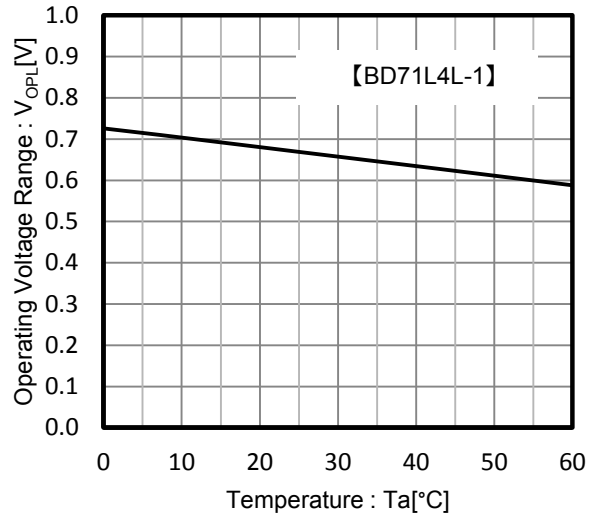

Figure 7. Operating Voltage Range vs. Temperature

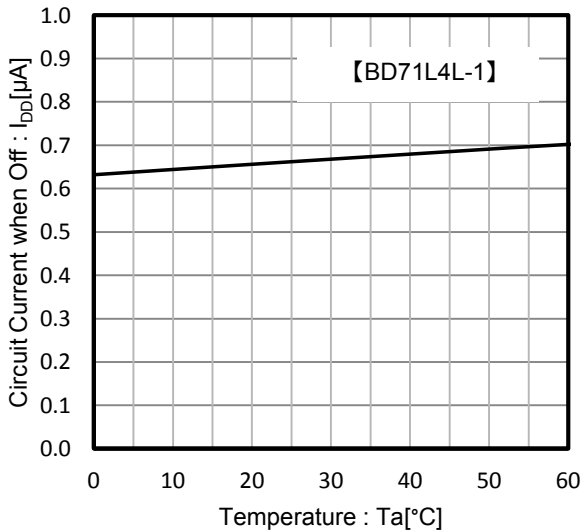

Figure 8. Supply Current when Off vs. Temperature

$$V_{DD} = V_{DET} - 0.2V$$

$$V_{DD} = 3.85V$$

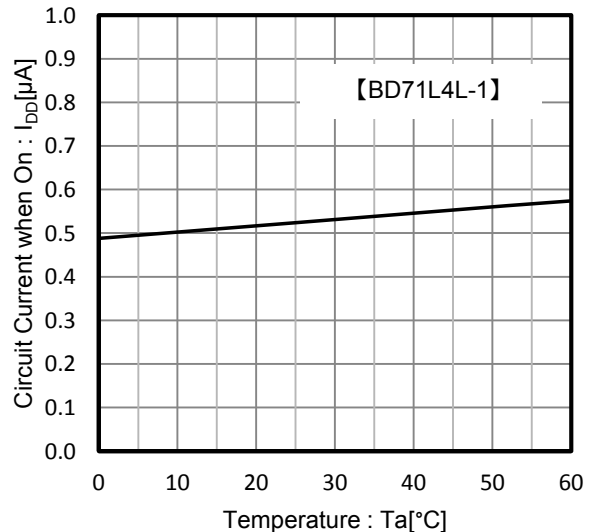

Figure 9. Supply Current when On vs. Temperature

$$V_{DD} = V_{DET} + 0.2V$$

$$V_{DD} = 4.25V$$

Typical Performance Curves – continued

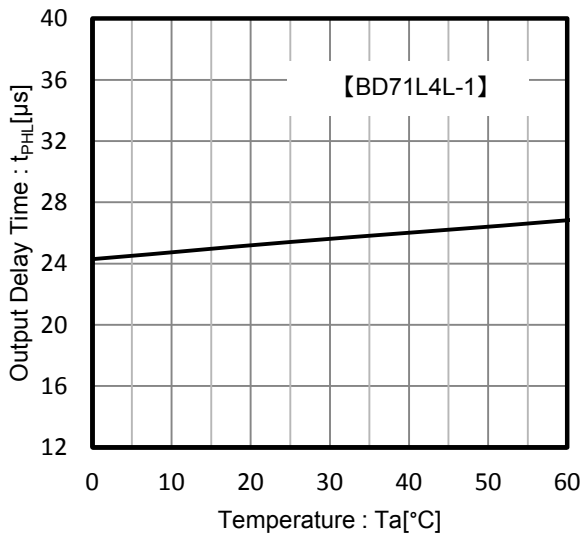

Figure 10. Output Delay Time (t_{PHL})

V_{DD}=V_{DET}-0.5V to V_{DET}+0.5V

V_{DD}=3.55V to 4.55V

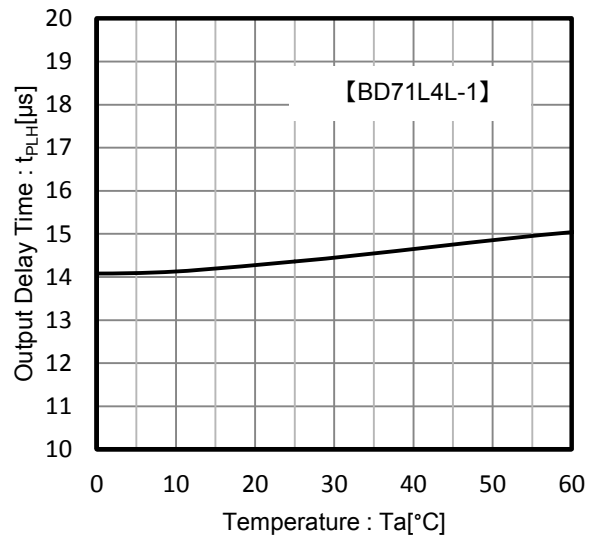

Figure 11. Output Delay Time (t_{PLH})

V_{DD}=V_{DET}+0.5V to V_{DET}-0.5V

V_{DD}=4.55V to 3.55V

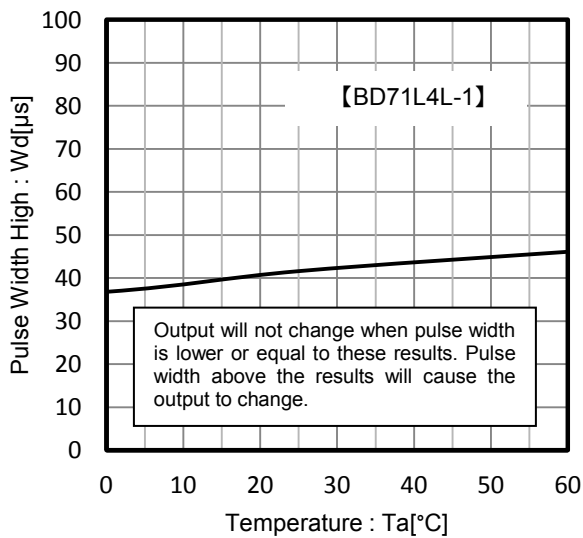

Figure 12. Pulse Width vs. Temperature

V_{DD-LOW}=1.2V, V_{DD-HIGH}=4.2V, C_{IN}=0.1μF

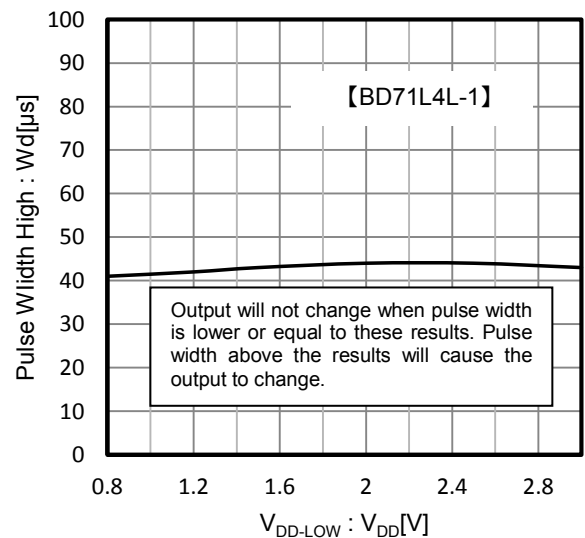

Figure 13. Pulse Width vs. Voltage Level

V_{DD-HIGH}=4.2V, C_{IN}=0.1μF, Ta=25°C

Application Information

1. Explanation of Operation

The detection and release voltages are used as threshold voltages. When the voltage applied to VDD pin reaches the appropriate threshold voltage, OUT pin voltage switches from either “High” to “Low” or from “Low” to “High”. Please refer to the Timing Waveform and Electrical Characteristics for information on hysteresis.

Because the BD71L4L-1 uses an open drain output type, it is necessary to connect a pull-up resistor to VDD or another power supply if needed [The output “High” voltage (V_{OUT}) in this case becomes V_{DD} or the voltage of the other power supply].

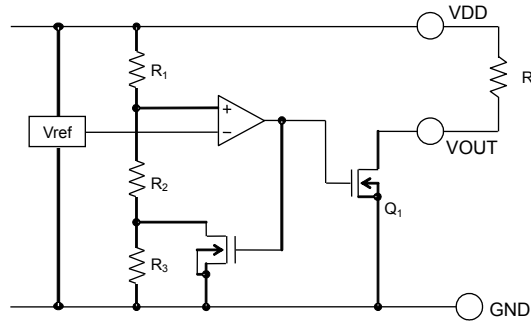

Figure 14. Internal Block Diagram

2. Timing Waveform

Example: the following shows the relationship between the input voltage (V_{DD}) and the output voltage (V_{OUT}) when the input power supply voltage (V_{DD}) swept up and down (the circuit is shown in Figure 14).

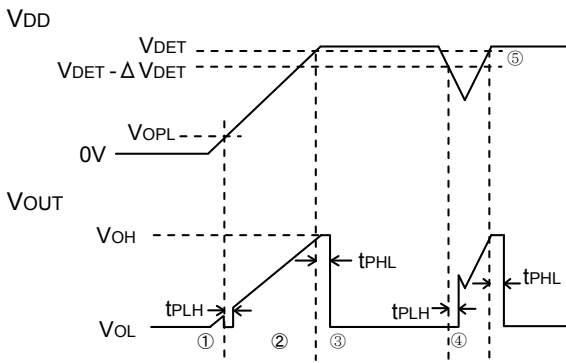

Figure 15. Timing Waveform

- ① When the power supply is turned on, the output is unstable from after over the operating limit voltage (V_{OPL}) until t_{PLH} . Therefore it is possible that the reset signal is not outputted when the rise time of V_{DD} is faster than t_{PLH} .
- ② When V_{DD} is greater than V_{OPL} but less than the reset detection voltage (V_{DET}), the output voltage will switch to High.
- ③ If V_{DD} exceeds the reset detection voltage (V_{DET}) when the power supply is powered up, V_{OUT} switches from H to L (with a delay of t_{PLH}).
- ④ If V_{DD} drops below the release voltage ($V_{DET} - \Delta V_{DET}$) when the power supply is powered down, V_{OUT} switches to H (with a delay of t_{PLH}).
- ⑤ The potential difference between the detection voltage and the release voltage is known as the hysteresis width (ΔV_{DET}).

3. Circuit Applications

(1) Example of common power supply detection reset circuit.

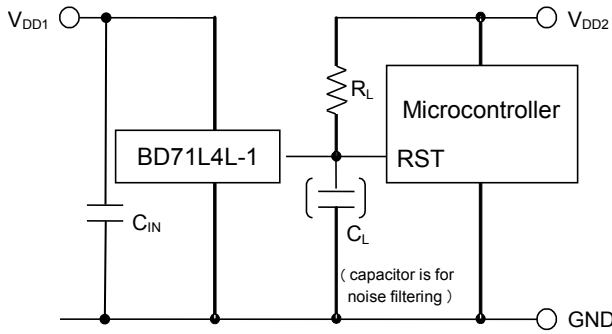

Figure 16. Open Drain Output Type

CASE1: Power supply of the microcontroller (V_{DD2}) differs from the power supply of the reset detection IC (V_{DD1}). Attach a load resistance R_L between output of reset detection IC and V_{DD2} as shown in Figure 16.

CASE2: Power supply of the microcontroller (V_{DD1}) is same as the power supply of the reset detection IC (V_{DD1}). Connect a pull up resistor between output and V_{DD1} .

This IC's hysteresis between detection voltage and release voltage is 30mV(typ), so when the V_{OUT} logic changes, chattering occurs.

C_{IN} value needs more than 0.1uF to eliminate this.

When a capacitance C_L for noise filtering is connected to the OUT pin (the reset signal input terminal of the microcontroller), please take into account the rise and fall waveform of the output voltage (V_{OUT}).

(2) The following is an example of a circuit application in which an OR connection between two types of detection voltage resets the microcontroller.

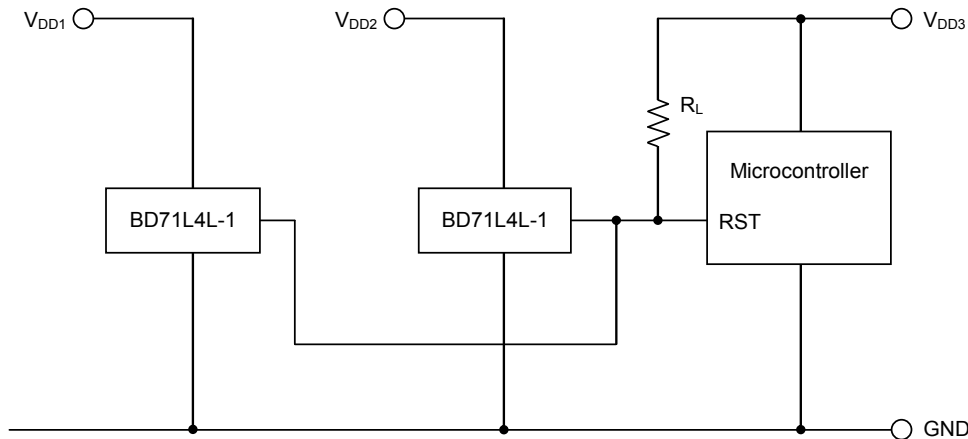

Figure 17. OR Circuit Connection Application

To reset the microcontroller when many independent power supplies are used in the system, OR connect the device to microcontroller's input with pull-up resistor to the supply voltage of the microcontroller (V_{DD3}) as shown in Figure 17. By pulling-up to V_{DD3} , output "High" voltage of micro-controller power supply is possible.

Circuit Applications (continued)

(3) Example of power supply with resistor dividers

In applications wherein the power supply voltage of an IC comes from a resistor divider circuit, an inrush current will flow into the circuit when the output level switches from “High” to “Low” or vice versa. Inrush current is a sudden surge of current that flows from the power supply (V_{DD}) to ground (GND) as the output logic changes its state. This current flow may cause malfunction in the systems operation such as output oscillations, etc.

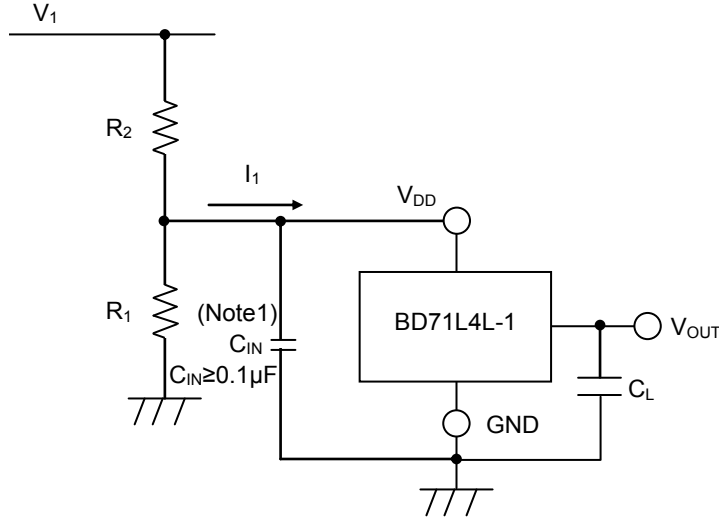

Figure 18. Resistor Divider Connection Application

Input voltage will decrease by a drop of $[I_{inrush} \times R_2]$ because of the inrush current at the time when the output switches from “High” to “Low”. When the input voltage decreases and falls below the release voltage $[V_{DET} - \Delta V_{DET}]$, the output voltage switches from “Low” to “High”. At this time, the inrush current stops flowing through output “High”, and the voltage drop is reduced. As a result, the output switches from “High” to “Low”, which again causes the inrush current to flow and the voltage to drop. This operation repeats and will result to oscillation. In case resistor divider will not use and only R_2 will use, same response will happen.

Note1: The circuit connection mentioned above does not guarantee successful operation.

Please perform thorough evaluation using the actual application and set countermeasures.

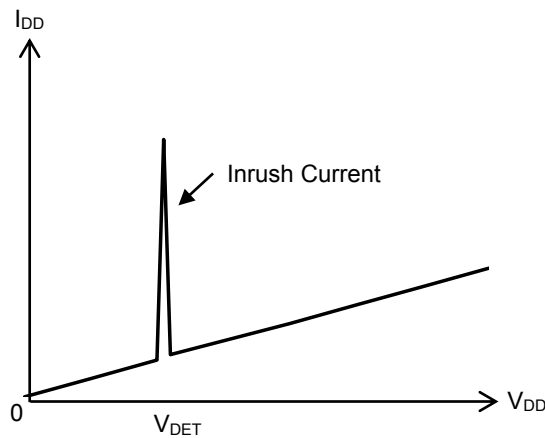

Figure 19. Current Consumption vs. Power Supply Voltage

Operational Notes

1. Reverse Connection of Power Supply

Connecting the power supply in reverse polarity can damage the IC. Take precautions against reverse polarity when connecting the power supply, such as mounting an external diode between the power supply and the IC's power supply pins.

2. Power Supply Lines

Design the PCB layout pattern to provide low impedance supply lines. Furthermore, connect a capacitor to ground at all power supply pins. Consider the effect of temperature and aging on the capacitance value when using electrolytic capacitors.

3. Ground Voltage

Ensure that no pins are at a voltage below that of the ground pin at any time, even during transient condition.

4. Ground Wiring Pattern

When using both small-signal and large-current ground traces, the two ground traces should be routed separately but connected to a single ground at the reference point of the application board to avoid fluctuations in the small-signal ground caused by large currents. Also ensure that the ground traces of external components do not cause variations on the ground voltage. The ground lines must be as short and thick as possible to reduce line impedance.

5. Thermal Consideration

Should by any chance the maximum junction temperature rating be exceeded the rise in temperature of the chip may result in deterioration of the properties of the chip. In case of exceeding this absolute maximum rating, increase the board size and copper area to prevent exceeding the maximum junction temperature rating.

6. Recommended Operating Conditions

These conditions represent a range within which the expected characteristics of the IC can be approximately obtained. The electrical characteristics are guaranteed under the conditions of each parameter.

7. Inrush Current

When power is first supplied to the IC, it is possible that the internal logic may be unstable and inrush current may flow instantaneously due to the internal powering sequence and delays, especially if the IC has more than one power supply. Therefore, give special consideration to power coupling capacitance, power wiring, width of ground wiring, and routing of connections.

8. Operation Under Strong Electromagnetic Field

Operating the IC in the presence of a strong electromagnetic field may cause the IC to malfunction.

9. Testing on Application Boards

When testing the IC on an application board, connecting a capacitor directly to a low-impedance output pin may subject the IC to stress. Always discharge capacitors completely after each process or step. The IC's power supply should always be turned off completely before connecting or removing it from the test setup during the inspection process. To prevent damage from static discharge, ground the IC during assembly and use similar precautions during transport and storage.

10. Inter-pin Short and Mounting Errors

Ensure that the direction and position are correct when mounting the IC on the PCB. Incorrect mounting may result in damaging the IC. Avoid nearby pins being shorted to each other especially to ground. Inter-pin shorts could be due to many reasons such as metal particles, water droplets (in very humid environment) and unintentional solder bridge deposited in between pins during assembly to name a few.

11. Unused Input Pins

Input pins of an IC are often connected to the gate of a MOS transistor. The gate has extremely high impedance and extremely low capacitance. If left unconnected, the electric field from the outside can easily charge it. The small charge acquired in this way is enough to produce a significant effect on the conduction through the transistor and cause unexpected operation of the IC. So unless otherwise specified, unused input pins should be connected to the power supply or ground line.

Operational Notes – continued**12. Regarding Input Pins of the IC**

In the construction of this IC, P-N junctions are inevitably formed creating parasitic diodes or transistors. The operation of these parasitic elements can result in mutual interference among circuits, operational faults, or physical damage. Therefore, conditions which cause these parasitic elements to operate, such as applying a voltage to an input pin lower than the ground voltage should be avoided. Furthermore, do not apply a voltage to the input pins when no power supply voltage is applied to the IC. Even if the power supply voltage is applied, make sure that the input pins have voltages within the values specified in the electrical characteristics of this IC.

13. Ceramic Capacitor

When using a ceramic capacitor, determine the dielectric constant considering the change of capacitance with temperature and the decrease in nominal capacitance due to DC bias and others.

14. Area of Safe Operation (ASO)

Operate the IC such that the output voltage, output current, and the maximum junction temperature rating are all within the Area of Safe Operation (ASO).

15. Bypass Capacitor for Noise Rejection

To help reject noise, put more than 0.1 μ F capacitor between VDD pin and GND and 1000pF capacitor between VOUT pin and GND. Be careful when using extremely big capacitor as transient response will be affected.

16. The V_{DD} line impedance might cause oscillation because of the detection current.

17. A V_{DD} to GND capacitor (as close connection as possible) should be used in high V_{DD} line impedance condition.

18. External Parameters

The recommended parameter range for R_L is 10k Ω to 1M Ω . There are many factors (board layout, etc) that can affect characteristics. Operating beyond the recommended values does not guarantee correct operation. Please verify and confirm using practical applications.

19. When V_{DD} falls below the minimum operating voltage, output becomes unstable. When output is connected to pull-up voltage, output will be equivalent to pull-up voltage.

20. Power-on Reset Operation

Please note that the power on reset output varies with the V_{DD} rise time. Please verify the behavior in the actual operation.

21. This IC has extremely high impedance pins. Small leak current due to the uncleanness of PCB surface might cause unexpected operations. Application values in these conditions should be selected carefully. If the leakage is assumed between the VOUT pin and the GND pin, consider to set the value of pull up resistor lower than 1/10 of the impedance of assumed leakage route.

Physical Dimension, Tape and Reel Information

Package Name	SSOP5
--------------	-------

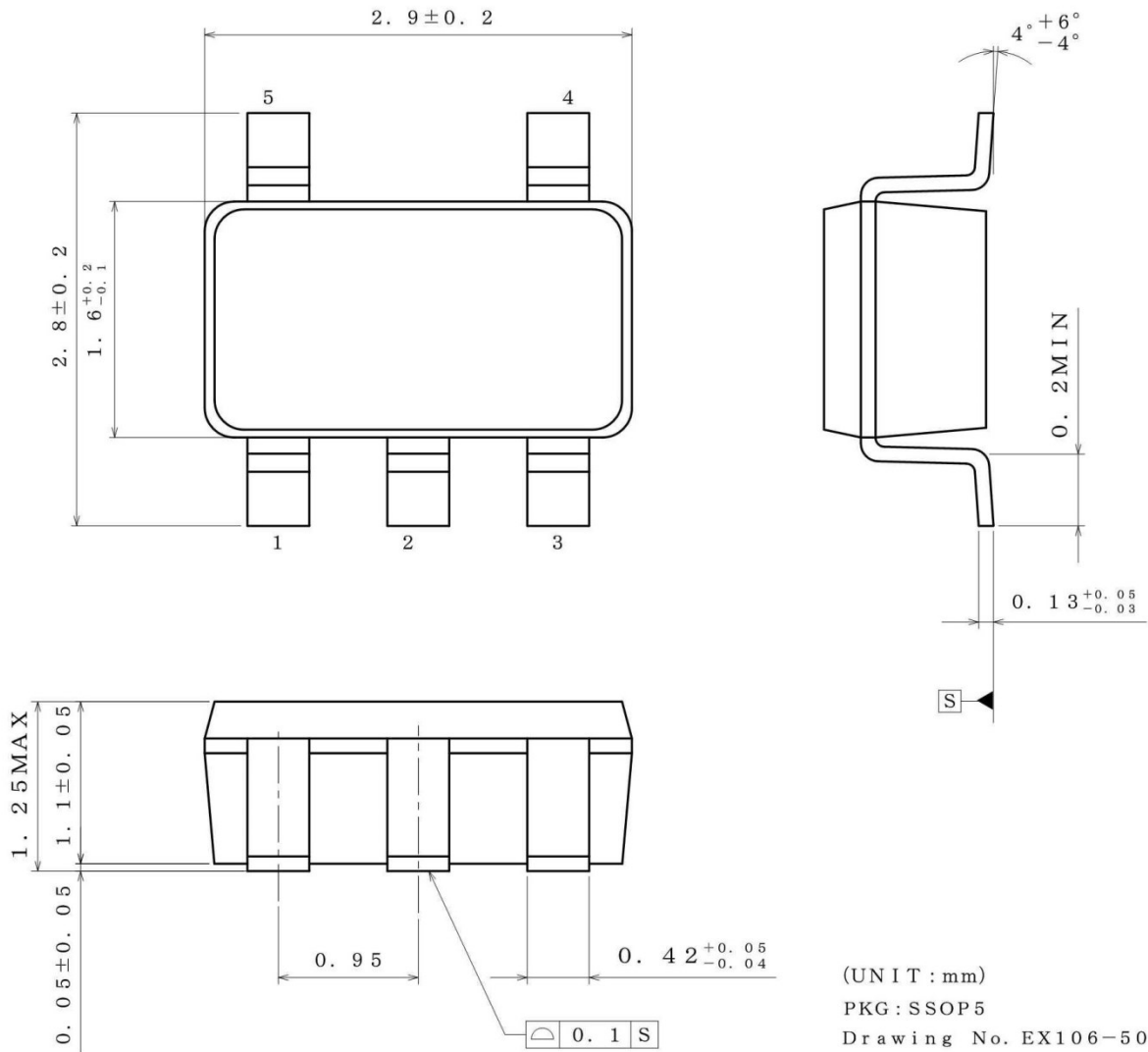

< Tape and Reel Information >

Tape	Embossed carrier tape
Quantity	3000pcs
Direction of feed	TR (The direction is the 1pin of product is at the upper right when you hold) (reel on the left hand and you pull out the tape on the right hand)

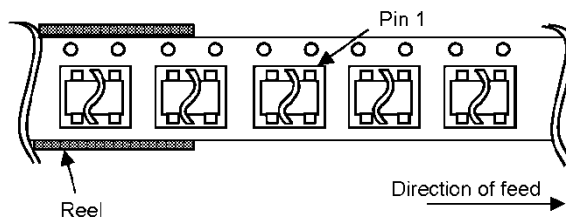

Package Name	HVSOF5
--------------	--------

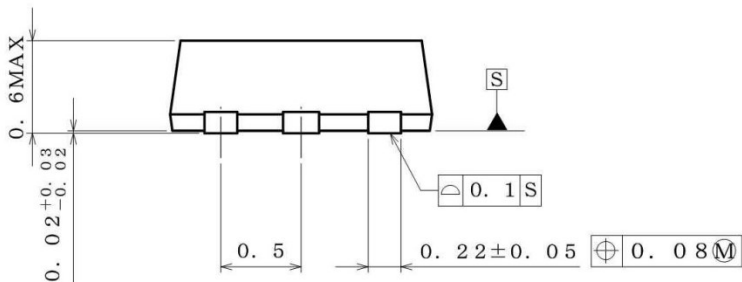
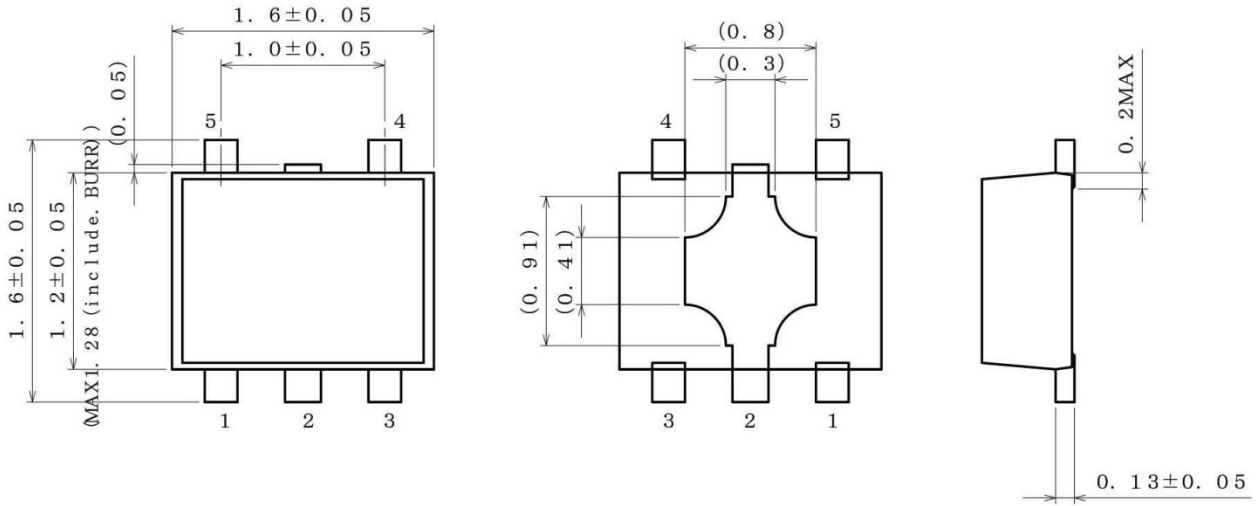

(UNIT : mm)
 PKG : HVSOF5
 Drawing No. EX108-5002

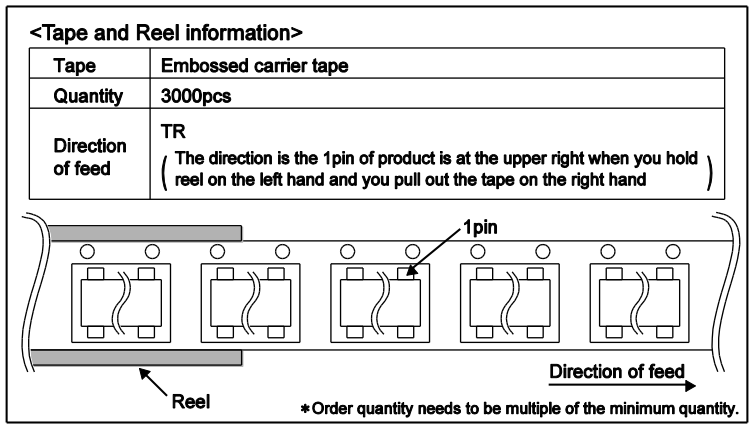

Revision History

Date	Revision	Changes
20.May.2013	001	New Release
24.July.2013	002	Modify the general description and applications on page 1 Changed VDET spec on pages 1 ~ 3 Changed IDD1 and IDD2 spec on page 3 Changed I _{leak} condition on page 3
24.Oct.2013	003	Add 1 packages as following:HVSO5F5
31.Jan.2014	004	Modify the package on page 1 and the connection diagram on page 2 Add note of HVSO5F5 on page 2
08.Jun.2016	005	Add package dimension on page 1 Add note for SSOP5 NC pin on page 2 Updated application information on page 7 ~ 9 Updated operational notes on page 10 ~ 11

Notice

Precaution on using ROHM Products

- Our Products are designed and manufactured for application in ordinary electronic equipments (such as AV equipment, OA equipment, telecommunication equipment, home electronic appliances, amusement equipment, etc.). If you intend to use our Products in devices requiring extremely high reliability (such as medical equipment ^(Note 1), transport equipment, traffic equipment, aircraft/spacecraft, nuclear power controllers, fuel controllers, car equipment including car accessories, safety devices, etc.) and whose malfunction or failure may cause loss of human life, bodily injury or serious damage to property ("Specific Applications"), please consult with the ROHM sales representative in advance. Unless otherwise agreed in writing by ROHM in advance, ROHM shall not be in any way responsible or liable for any damages, expenses or losses incurred by you or third parties arising from the use of any ROHM's Products for Specific Applications.

(Note1) Medical Equipment Classification of the Specific Applications

JAPAN	USA	EU	CHINA
CLASS III	CLASS III	CLASS II b	CLASS III
CLASS IV		CLASS III	

- ROHM designs and manufactures its Products subject to strict quality control system. However, semiconductor products can fail or malfunction at a certain rate. Please be sure to implement, at your own responsibilities, adequate safety measures including but not limited to fail-safe design against the physical injury, damage to any property, which a failure or malfunction of our Products may cause. The following are examples of safety measures:
 - Installation of protection circuits or other protective devices to improve system safety
 - Installation of redundant circuits to reduce the impact of single or multiple circuit failure
- Our Products are designed and manufactured for use under standard conditions and not under any special or extraordinary environments or conditions, as exemplified below. Accordingly, ROHM shall not be in any way responsible or liable for any damages, expenses or losses arising from the use of any ROHM's Products under any special or extraordinary environments or conditions. If you intend to use our Products under any special or extraordinary environments or conditions (as exemplified below), your independent verification and confirmation of product performance, reliability, etc. prior to use, must be necessary:
 - Use of our Products in any types of liquid, including water, oils, chemicals, and organic solvents
 - Use of our Products outdoors or in places where the Products are exposed to direct sunlight or dust
 - Use of our Products in places where the Products are exposed to sea wind or corrosive gases, including Cl₂, H₂S, NH₃, SO₂, and NO₂
 - Use of our Products in places where the Products are exposed to static electricity or electromagnetic waves
 - Use of our Products in proximity to heat-producing components, plastic cords, or other flammable items
 - Sealing or coating our Products with resin or other coating materials
 - Use of our Products without cleaning residue of flux (even if you use no-clean type fluxes, cleaning residue of flux is recommended); or Washing our Products by using water or water-soluble cleaning agents for cleaning residue after soldering
 - Use of the Products in places subject to dew condensation
- The Products are not subject to radiation-proof design.
- Please verify and confirm characteristics of the final or mounted products in using the Products.
- In particular, if a transient load (a large amount of load applied in a short period of time, such as pulse. is applied, confirmation of performance characteristics after on-board mounting is strongly recommended. Avoid applying power exceeding normal rated power; exceeding the power rating under steady-state loading condition may negatively affect product performance and reliability.
- De-rate Power Dissipation depending on ambient temperature. When used in sealed area, confirm that it is the use in the range that does not exceed the maximum junction temperature.
- Confirm that operation temperature is within the specified range described in the product specification.
- ROHM shall not be in any way responsible or liable for failure induced under deviant condition from what is defined in this document.

Precaution for Mounting / Circuit board design

- When a highly active halogenous (chlorine, bromine, etc.) flux is used, the residue of flux may negatively affect product performance and reliability.
- In principle, the reflow soldering method must be used on a surface-mount products, the flow soldering method must be used on a through hole mount products. If the flow soldering method is preferred on a surface-mount products, please consult with the ROHM representative in advance.

For details, please refer to ROHM Mounting specification

Precautions Regarding Application Examples and External Circuits

1. If change is made to the constant of an external circuit, please allow a sufficient margin considering variations of the characteristics of the Products and external components, including transient characteristics, as well as static characteristics.
2. You agree that application notes, reference designs, and associated data and information contained in this document are presented only as guidance for Products use. Therefore, in case you use such information, you are solely responsible for it and you must exercise your own independent verification and judgment in the use of such information contained in this document. ROHM shall not be in any way responsible or liable for any damages, expenses or losses incurred by you or third parties arising from the use of such information.

Precaution for Electrostatic

This Product is electrostatic sensitive product, which may be damaged due to electrostatic discharge. Please take proper caution in your manufacturing process and storage so that voltage exceeding the Products maximum rating will not be applied to Products. Please take special care under dry condition (e.g. Grounding of human body / equipment / solder iron, isolation from charged objects, setting of Ionizer, friction prevention and temperature / humidity control).

Precaution for Storage / Transportation

1. Product performance and soldered connections may deteriorate if the Products are stored in the places where:
 - [a] the Products are exposed to sea winds or corrosive gases, including Cl₂, H₂S, NH₃, SO₂, and NO₂
 - [b] the temperature or humidity exceeds those recommended by ROHM
 - [c] the Products are exposed to direct sunshine or condensation
 - [d] the Products are exposed to high Electrostatic
2. Even under ROHM recommended storage condition, solderability of products out of recommended storage time period may be degraded. It is strongly recommended to confirm solderability before using Products of which storage time is exceeding the recommended storage time period.
3. Store / transport cartons in the correct direction, which is indicated on a carton with a symbol. Otherwise bent leads may occur due to excessive stress applied when dropping of a carton.
4. Use Products within the specified time after opening a humidity barrier bag. Baking is required before using Products of which storage time is exceeding the recommended storage time period.

Precaution for Product Label

A two-dimensional barcode printed on ROHM Products label is for ROHM's internal use only.

Precaution for Disposition

When disposing Products please dispose them properly using an authorized industry waste company.

Precaution for Foreign Exchange and Foreign Trade act

Since concerned goods might be fallen under listed items of export control prescribed by Foreign exchange and Foreign trade act, please consult with ROHM in case of export.

Precaution Regarding Intellectual Property Rights

1. All information and data including but not limited to application example contained in this document is for reference only. ROHM does not warrant that foregoing information or data will not infringe any intellectual property rights or any other rights of any third party regarding such information or data.
2. ROHM shall not have any obligations where the claims, actions or demands arising from the combination of the Products with other articles such as components, circuits, systems or external equipment (including software).
3. No license, expressly or implied, is granted hereby under any intellectual property rights or other rights of ROHM or any third parties with respect to the Products or the information contained in this document. Provided, however, that ROHM will not assert its intellectual property rights or other rights against you or your customers to the extent necessary to manufacture or sell products containing the Products, subject to the terms and conditions herein.

Other Precaution



1. This document may not be reprinted or reproduced, in whole or in part, without prior written consent of ROHM.
2. The Products may not be disassembled, converted, modified, reproduced or otherwise changed without prior written consent of ROHM.
3. In no event shall you use in any way whatsoever the Products and the related technical information contained in the Products or this document for any military purposes, including but not limited to, the development of mass-destruction weapons.
4. The proper names of companies or products described in this document are trademarks or registered trademarks of ROHM, its affiliated companies or third parties.

General Precaution

1. Before you use our Products, you are requested to carefully read this document and fully understand its contents. ROHM shall not be in any way responsible or liable for failure, malfunction or accident arising from the use of any ROHM's Products against warning, caution or note contained in this document.
2. All information contained in this document is current as of the issuing date and subject to change without any prior notice. Before purchasing or using ROHM's Products, please confirm the latest information with a ROHM sales representative.
3. The information contained in this document is provided on an "as is" basis and ROHM does not warrant that all information contained in this document is accurate and/or error-free. ROHM shall not be in any way responsible or liable for any damages, expenses or losses incurred by you or third parties resulting from inaccuracy or errors of or concerning such information.

Looking for pricing, stock, or lifecycle information?

Click below to explore more details on WIN SOURCE:

-  [View BD71L4LHFV-1GTR on WIN SOURCE](#)
-  [Rohm Semiconductor](#) Information

Optimize Your Supply Chain with WIN SOURCE Solutions

-  Global Sourcing Solution
-  Obsolete Management
-  Cost Control Management
-  Shortage Management
-  Alternative Solution
-  Excess Inventory Management