



**THE DATASHEET OF
MAX13051ESA+**



±80V Fault-Protected Can Transceiver with Autobaud

General Description

The MAX13051 ±80V fault-protected CAN transceiver with autobaud is ideal for device net and other industrial network applications where overvoltage protection is required. The MAX13051 provides a link between the CAN protocol controller and the physical wires of the bus lines in a control area network (CAN).

The MAX13051 features three different modes of operation: high speed, slope control, and standby. High-speed mode allows data rates up to 1Mbps. The slope-control mode can be used to program the slew rate of the transmitter for data rates of up to 500kbps, reducing the effects of EMI and allowing the use of unshielded-twisted or parallel cable. In standby mode, the transmitter shuts off and a low-power receiver monitors the bus, waiting for a wake-up signal.

The MAX13051 provides a transmitter data (TXD) dominant timeout function that prevents erroneous CAN controllers from clamping the bus to a dominant level if the TXD input is held low for greater than 1ms. The MAX13051 also provides an autobaud feature allowing the microcontroller to compute the incoming baud rate without destroying CAN protocol communication. The MAX13051 input common-mode range is greater than ±12V, exceeding the ISO 11898 specification of -2V to +7V, and features ±6kV Human Body Model protection, making these devices ideal for harsh environments. The MAX13051 is available in an 8-pin SO package and is specified from the -40°C to +85°C and -40°C to +125°C temperature ranges.

Applications

Industrial Networks
Device Net Nodes
Telecom
HVAC

Pin Configuration

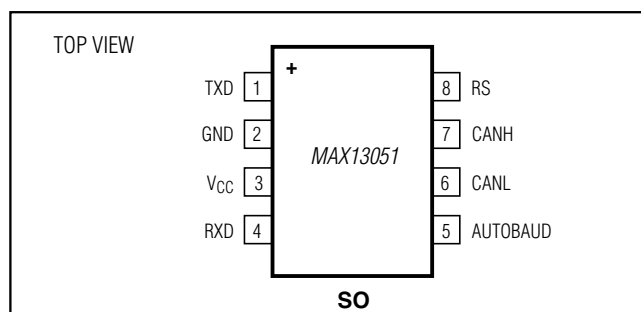

Features

- ◆ Fully Compatible with the ISO 11898 Standard
- ◆ Autobaud Mode
- ◆ Short-Circuit Protection
- ◆ High-Speed Operation Up to 1Mbps
- ◆ Slope-Control Mode
- ◆ Low-Current Standby Mode
- ◆ Thermal Shutdown
- ◆ Transmit Data Dominant Timeout
- ◆ ±6kV Human Body Model ESD Protection
- ◆ Greater than ±12V Common-Mode Range

Ordering Information

PART	TEMP RANGE	PIN-PACKAGE
MAX13051ESA+	-40°C to +85°C	8 SO
MAX13051ASA+	-40°C to +125°C	8 SO

+Denotes a lead(Pb)-free/RoHS-compliant package.

Typical Operating Circuit

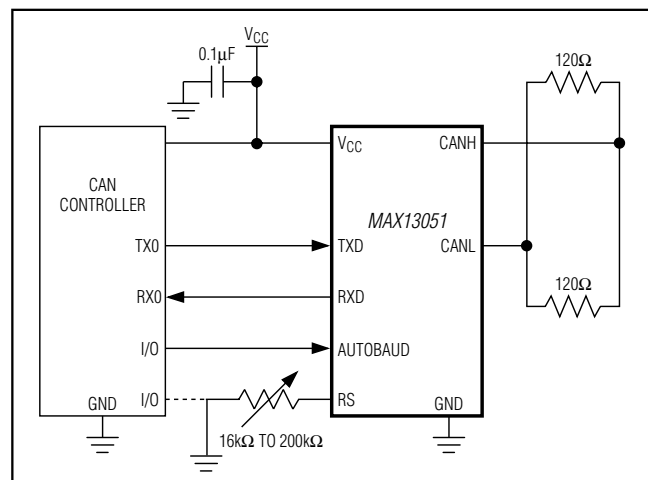

For pricing, delivery, and ordering information, please contact Maxim Direct at 1-888-629-4642, or visit Maxim's website at www.maximintegrated.com.

MAX13051

±80V Fault-Protected Can Transceiver with Autobaud

ABSOLUTE MAXIMUM RATINGS

(All voltages referenced to GND.)

V _{CC}	-0.3V to +6V
RS	-0.3V to (V _{CC} + 0.3V)
TXD, RXD, AUTOBAUD	-0.3V to +6V
CANH, CANL	±80V
Continuous Power Dissipation (T _A = +70°C)	
8-Pin SO (derate 5.9mW/°C above +70°C)	470mW

Operating Temperature Range	-40°C to +125°C
Junction Temperature	+150°C
Storage Temperature Range	-65°C to +150°C
Lead Temperature (soldering, 10s)	+300°C
Soldering Temperature (reflow)	+260°C

Stresses beyond those listed under "Absolute Maximum Ratings" may cause permanent damage to the device. These are stress ratings only, and functional operation of the device at these or any other conditions beyond those indicated in the operational sections of the specifications is not implied. Exposure to absolute maximum rating conditions for extended periods may affect device reliability.

DC ELECTRICAL CHARACTERISTICS

(V_{CC} = +5V ±5%, T_A = T_{MIN} to T_{MAX}, unless otherwise noted. Typical values are at V_{CC} = +5V, T_A = +25°C.) (Note 1)

PARAMETER	SYMBOL	CONDITIONS	MIN	TYP	MAX	UNITS
Supply Current	I _{CC}	Dominant, R _L = 60Ω			72	mA
		Recessive			15	
Standby Current	I _{STANDBY}				25	μA
Thermal-Shutdown Threshold	V _{TSH}			+165		°C
Thermal-Shutdown Hysteresis				13		°C
INPUT LEVELS (TXD, AUTOBAUD)						
High-Level Input Voltage	V _{IH}		2			V
Low-Level Input Voltage	V _{IL}				0.8	V
High-Level Input Current	I _{IH}	V _{TXD} = V _{CC}	-5		+5	μA
		V _{AUTOBAUD} = V _{CC}	+5		+15	
Low-Level Input Current	I _{IL}	V _{TXD} = GND	-300		-100	μA
		V _{AUTOBAUD} = GND	-5		+5	
Input Capacitance	C _{IN}			10		pF
CANH, CANL TRANSMITTER						
Recessive Bus Voltage	V _{CANH} , V _{CANL}	Normal mode, V _{TXD} = V _{CC} , no load	2		3	V
		Standby mode, no load	-100		+100	mV
Recessive Output Current	I _{CANH} , I _{CANL}	-76V < V _{CANH} , V _{CANL} < +76V		±3		mA
		-32V < V _{CANH} , V _{CANL} < +32V	-2.5		+2.5	
CANH Output Voltage	V _{CANH}	V _{TXD} = 0V, dominant	3.0		4.5	V
CANL Output Voltage	V _{CANL}	V _{TXD} = 0V, dominant	0.50		1.75	V
Matching Between CANH and CANL Output Voltage	ΔDOM	V _{TXD} = 0V, dominant, T _A = +25°C (V _{CANH} + V _{CANL}) - V _{CC}	-100		+150	mV
Differential Output (V _{CANH} - V _{CANL})	V _{DIFF}	Dominant, V _{TXD} = 0V, 45Ω < R _L < 60Ω	1.5		3.0	V
		Recessive, V _{TXD} = V _{CC} , no load	-50		+50	mV
CANH Short-Circuit Current	I _{CANHSC}	V _{CANH} = 0V, V _{TXD} = 0V	-100	-70	-45	mA
CANL Short-Circuit Current	I _{CANLSC}	V _{CANL} = 5V, V _{TXD} = 0V	40	60	90	mA
		V _{CANL} = 40V, V _{TXD} = 0V	40	60	90	
		V _{CANL} = 76V, V _{TXD} = 0V		63		

MAX13051

±80V Fault-Protected Can Transceiver with Autobaud

DC ELECTRICAL CHARACTERISTICS (continued)

(V_{CC} = +5V ±5%, T_A = T_{MIN} to T_{MAX}, unless otherwise noted. Typical values are at V_{CC} = +5V, T_A = +25°C.) (Note 1)

PARAMETER	SYMBOL	CONDITIONS	MIN	TYP	MAX	UNITS
RXD OUTPUT LEVELS						
RXD High Output Voltage Level	V _{OH}	I = -100μA	0.8 × V _{CC}		V _{CC}	V
RXD Low Output Voltage Level	V _{OL}	I = 5mA			0.4	V
DC BUS RECEIVER (V _{TXD} = V _{CC} , CANH and CANL externally driven)						
Differential Input Voltage	V _{DIFF}	-12V < V _{CM} < +12V	0.5	0.7	0.9	V
		-12V < V _{CM} < +12V, standby mode	0.5		1.1	
Differential Input Hysteresis	V _{DIFF} (HYST)	Normal mode, -12V < V _{CM} < +12V		70		mV
Common-Mode Input Resistance	R _{ICM}	Normal or standby mode, V _{CANH} = V _{CANL} = ±12V	15		35	kΩ
Matching Between CANH and CANL Common-Mode Input Resistance	R _{IC_MATCH}		-3		+3	%
Differential Input Resistance	R _{DIFF}	Normal or standby mode, V _{CANH} - V _{CANL} = 1V	25		75	kΩ
Common-Mode Input Capacitance		V _{TXD} = V _{CC}		20		pF
Differential Input Capacitance		V _{TXD} = V _{CC}		10		pF
Input Leakage Current	I _{LI}	V _{CC} = 0V, V _{CANH} = V _{CANL} = 5V	-5		+5	μA
SLOPE CONTROL (RS)						
Input Voltage for High-Speed Mode	V _{IL_RS}				0.3 × V _{CC}	V
Input Voltage for Standby	V _{IH_RS}		0.75 × V _{CC}			V
Slope-Control Mode Voltage	V _{SLOPE}	-200μA < I _{RS} < 10μA	0.4 × V _{CC}		0.6 × V _{CC}	V
High-Speed Mode Current	I _{IL_RS}	V _{RS} = 0V	-500			μA

TIMING CHARACTERISTICS

(V_{CC} = +5V ±5%, R_L = 60Ω, C_L = 100pF, T_A = T_{MIN} to T_{MAX}, unless otherwise noted. Typical values are at V_{CC} = +5V and T_A = +25°C.)

PARAMETER	SYMBOL	CONDITIONS	MIN	TYP	MAX	UNITS
Delay TXD to Bus Active	t _{ONTXD}	V _{RS} = 0V (Figure 1)		66	110	ns
Delay TXD to Bus Inactive	t _{OFFTXD}	V _{RS} = 0V (Figure 1)		61	95	ns
Delay Bus to Receiver Active	t _{ONRXD}	V _{RS} = 0V (Figure 1)		54	115	ns
Delay Bus to Receiver Inactive	t _{OFFRXD}	V _{RS} = 0V (Figure 1)		46	160	ns
Delay TXD to RXD Active	t _{ONLOOP}	V _{RS} = 0V (Figure 1)		121	255	ns
Delay TXD to RXD Inactive	t _{OFFLOOP}	V _{RS} = 0V (Figure 1)		108	255	ns
Delay TXD to RXD Active (Dominant Loop Delay) Slew-Rate Controlled	t _{ONLOOP_S}	R _{RS} = 24kΩ (500kbps)		280	450	ns
		R _{RS} = 100kΩ (125kbps)		0.82	1.6	
		R _{RS} = 180kΩ (62.5kbps)		1.37	5	
Delay TXD to RXD Inactive (Loop Delay) Slew-Rate Controlled	t _{OFFLOOP_S}	R _{RS} = 24kΩ (500kbps)		386	600	ns
		R _{RS} = 100kΩ (125kbps)		0.74	1.6	
		R _{RS} = 180kΩ (62.5kbps)		0.97	5	

MAX13051

±80V Fault-Protected Can Transceiver with Autobaud

TIMING CHARACTERISTICS (continued)

($V_{CC} = +5V \pm 5\%$, $R_L = 60\Omega$, $C_L = 100pF$, $T_A = T_{MIN}$ to T_{MAX} , unless otherwise noted. Typical values are at $V_{CC} = +5V$ and $T_A = +25^\circ C$.)

PARAMETER	SYMBOL	CONDITIONS	MIN	TYP	MAX	UNITS
Differential-Output Slew Rate	SR	$R_{RS} = 24k\Omega$ (500kbps)		10		V/ μs
		$R_{RS} = 100k\Omega$ (125kbps)		2.7		
		$R_{RS} = 180k\Omega$ (62.5kbps)		1.6		
Dominant Time for Wake-Up Through Bus (Figure 2)	t_{WAKE}	Standby mode, $V_{DIFF} = 3V$	0.75	1.5	3.00	μs
TXD Dominant Timeout	t_{DOM}	$V_{TXD} = 0V$	0.3	0.6	1.0	ms
ESD Protection		Human Body Model (CANH, CANL)		6		kV

Note 1: All currents into device are positive and all currents out of the device are negative. All voltages are referenced to device ground unless otherwise noted.

Timing Diagrams

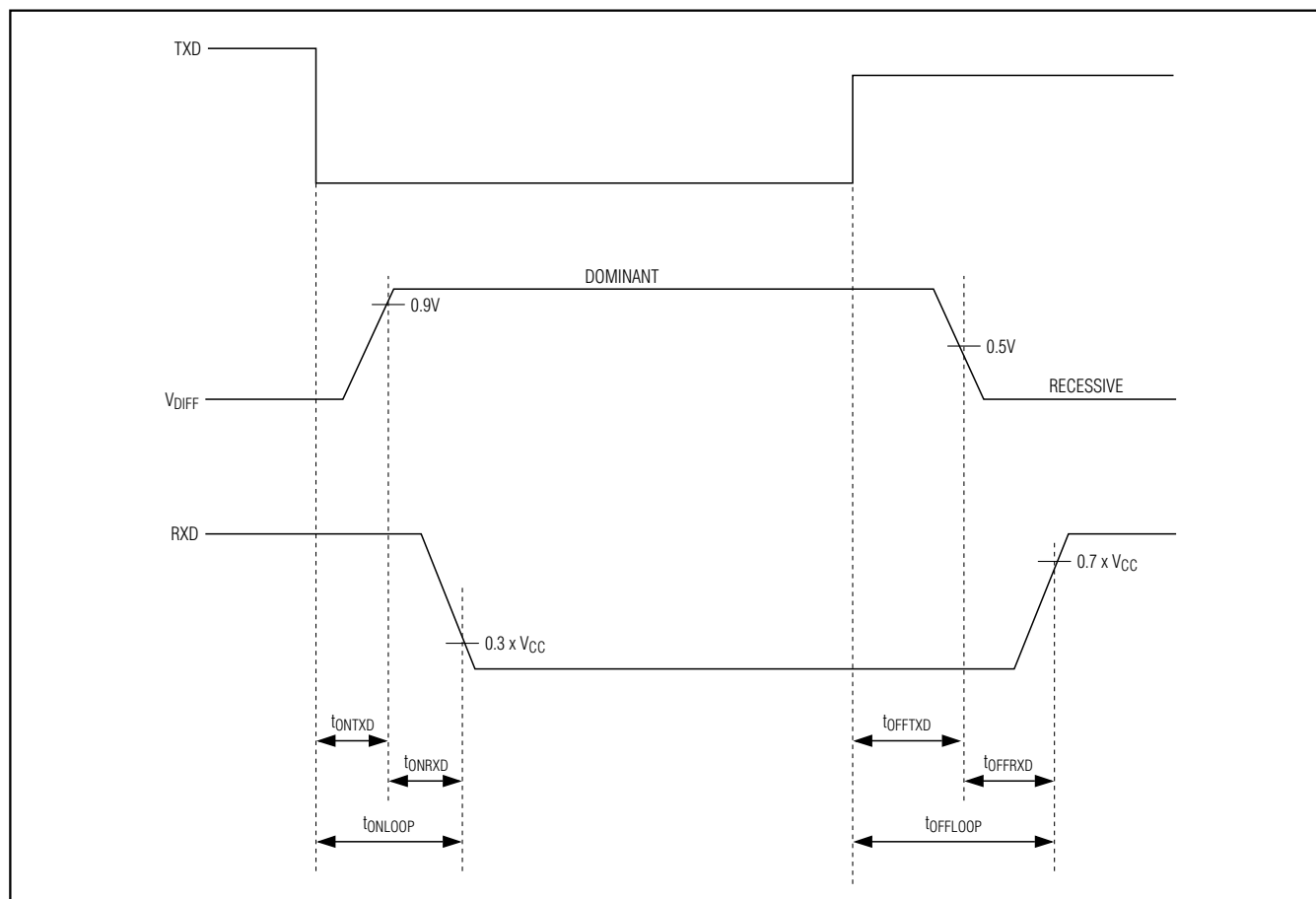

Figure 1. Timing Diagram

MAX13051

$\pm 80V$ Fault-Protected Can Transceiver with Autobaud

Timing Diagrams (continued)

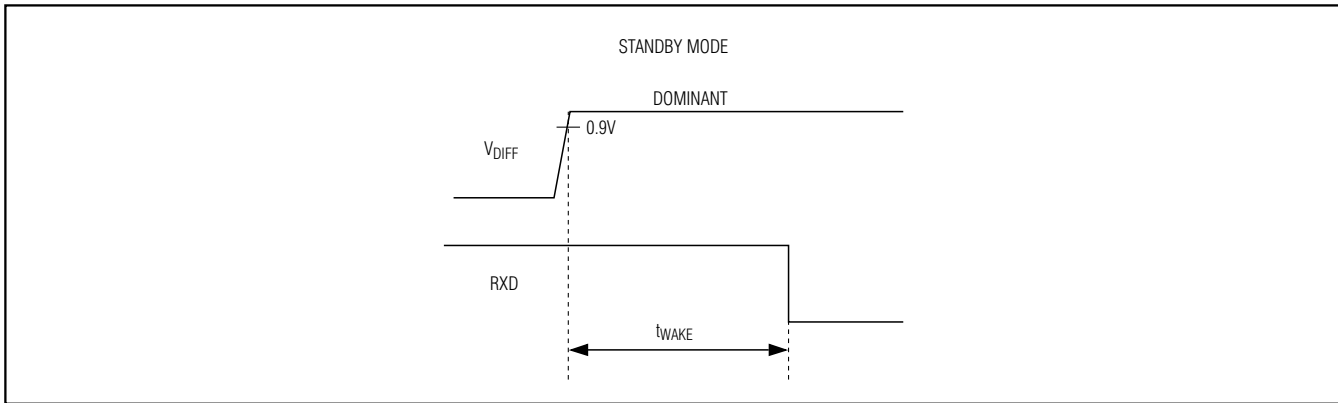
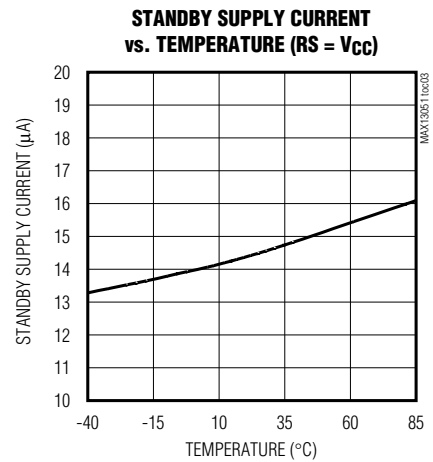
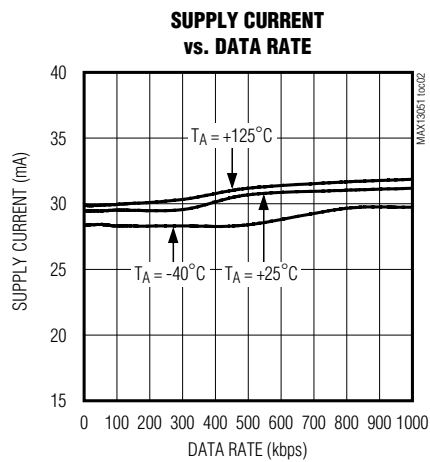
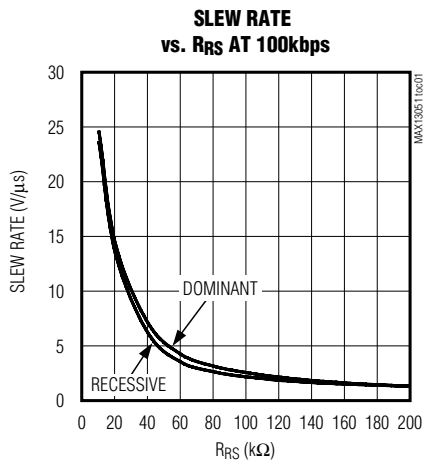

Figure 2. Timing Diagram for Standby and Wake-Up Signal

Typical Operating Characteristics

($V_{CC} = +5V$, $R_L = 60\Omega$, $C_L = 100pF$, $T_A = +25^\circ C$, unless otherwise specified.)



MAX13051

±80V Fault-Protected Can Transceiver with Autobaud

Typical Operating Characteristics (continued)

($V_{CC} = +5V$, $R_L = 60\Omega$, $C_L = 100pF$, $T_A = +25^\circ C$, unless otherwise specified.)

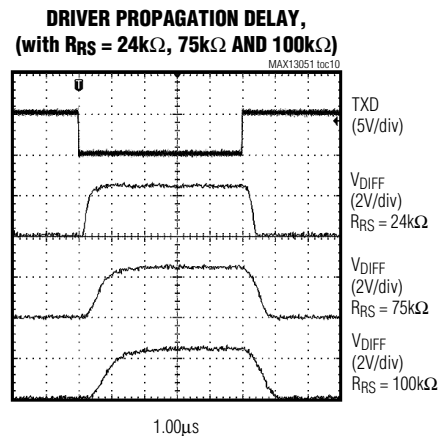
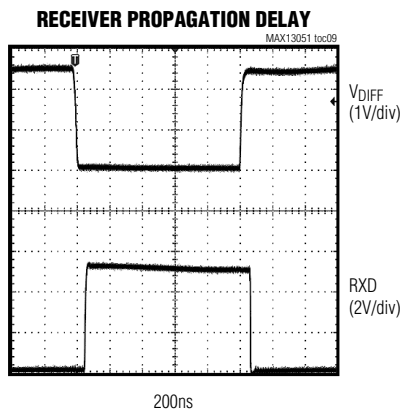
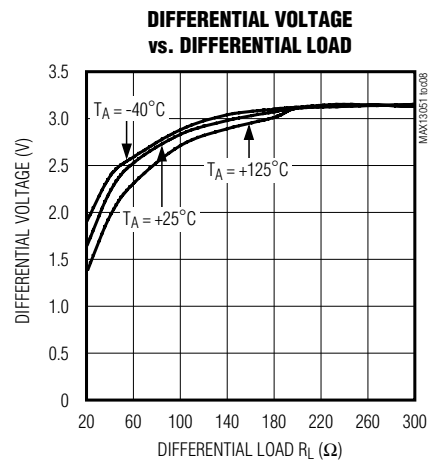
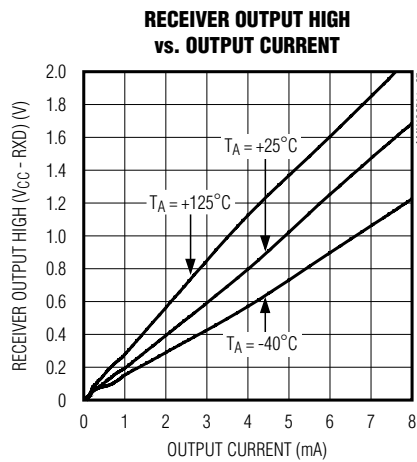
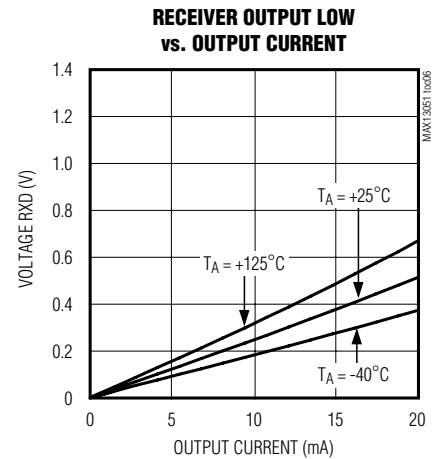
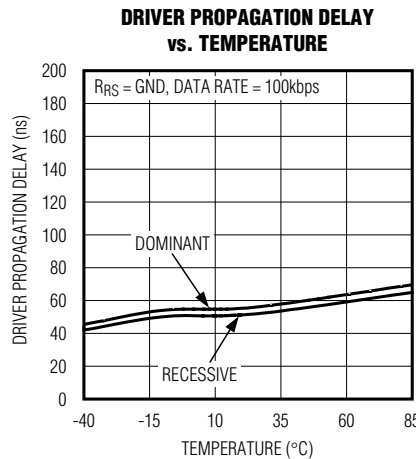
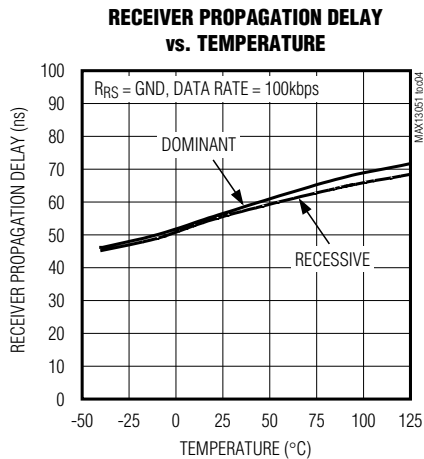

MAX13051

±80V Fault-Protected Can Transceiver with Autobaud

Typical Operating Characteristics (continued)

($V_{CC} = +5V$, $R_L = 60\Omega$, $C_L = 100pF$, $T_A = +25^\circ C$, unless otherwise specified.)

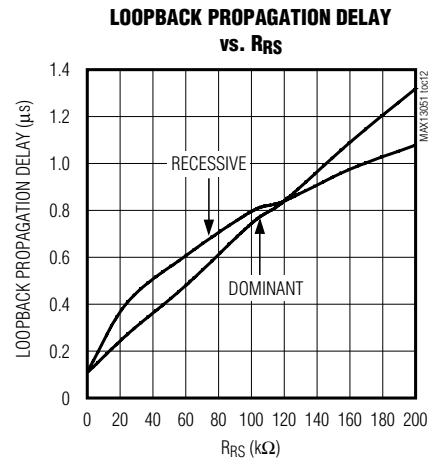
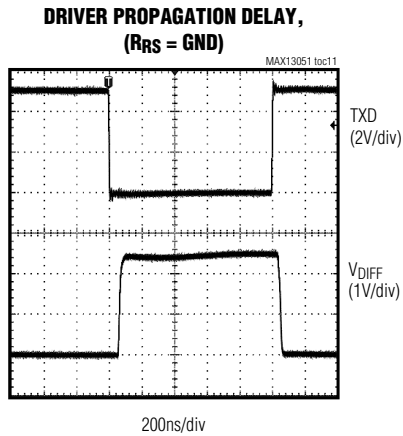

Pin Description

PIN	NAME	FUNCTION
1	TXD	Transmit Data Input. TXD is a CMOS/TTL-compatible input from a CAN controller.
2	GND	Ground
3	V_{CC}	Supply Voltage. Bypass V_{CC} to GND with a 0.1 μF capacitor.
4	RXD	Receive Data Output. RXD is a CMOS/TTL-compatible output from the physical bus lines CANH and CANL.
5	AUTOBAUD	Autobaud Input. Drive AUTOBAUD low for normal operation. Drive AUTOBAUD high for autobaud operation. When operating in autobaud mode, TXD is looped back to RXD without applying a differential signal at CANH and CANL.
6	CANL	CAN Bus Line Low
7	CANH	CAN Bus Line High
8	RS	Mode-Select Input. Drive RS low or connect to GND for high-speed operation. Connect a resistor between RS and GND to control output slope. Drive RS high to put into standby mode.

MAX13051

±80V Fault-Protected Can Transceiver with Autobaud

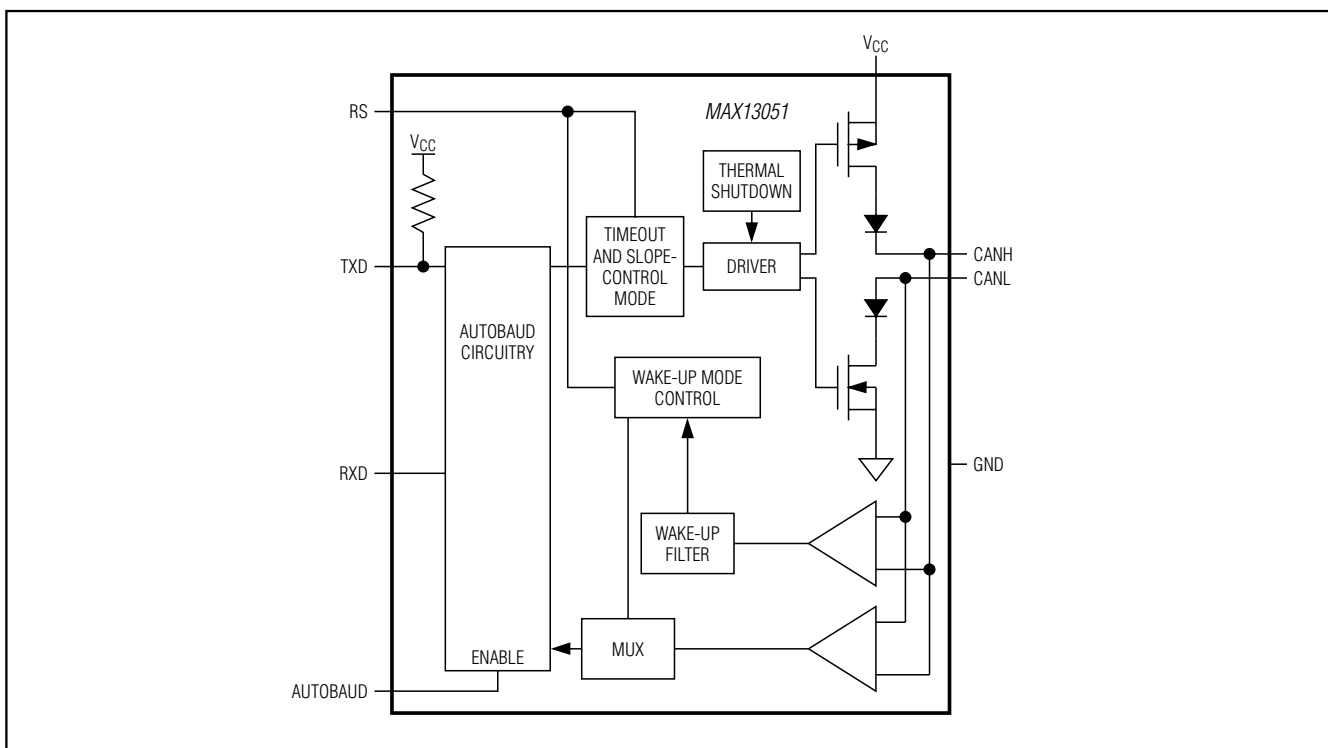

Figure 3. MAX13051 Functional Diagram

Detail Description

±80V Fault Tolerant

The MAX13051 features ±80V fault protection. This extended voltage range of CANH and CANL allows communication in high-voltage systems up to 80V.

Operating Modes

High-Speed Mode

The MAX13051 can achieve transmission rates of up to 1Mbps when operating in high-speed mode. To operate in high-speed mode, short RS to ground.

Slope-Control Mode

Connect a resistor from RS to ground to select slope-control mode (Table 1). In slope-control mode, CANH and CANL slew rates are controlled by the resistor, ($16\text{k}\Omega \leq R_{RS} \leq 200\text{k}\Omega$), connected between RS and GND. Controlling the rise and fall slopes reduces high-frequency EMI and allows the use of an unshielded-twisted pair or a parallel pair of wires as bus lines. The slew rate can be approximated using the formula below:

$$SR (V/\mu s) \approx \frac{250}{R_{RS}}$$

where, SR is the desired slew rate and R_{RS} is in $\text{k}\Omega$.

Standby Mode

In standby mode ($RS = \text{high}$), the transmitter is switched off and the receiver is switched to a low-current/low-speed state. The supply current reduces to $15\mu\text{A}$ to detect and recognize a wake-up event on the bus line. During standby mode, the bus line is monitored with a low-differential comparator. Once the comparator detects a dominant bus level greater than t_{WAKE} , RXD pulls low.

Autobaud Mode

The MAX13051 logic-controlled autobaud input allows a microcontroller to compute the incoming baud rate without destroying CAN protocol communication. When operating in autobaud mode, TXD is looped back to RXD without applying a differential signal at CANH and CANL. See Figure 4.

MAX13051

±80V Fault-Protected Can Transceiver with Autobaud

Table 1. Mode Selection Truth Table

CONDITION FORCED AT PIN RS	MODE	RESULTING CURRENT AT RS
$V_{RS} \leq 0.3V \times V_{CC}$	High Speed	$200\mu A \leq I_{RS} \leq 500\mu A$
$0.4V \times V_{CC} < V_{RS} \leq 0.6V \times V_{CC}$	Slope Control	$10\mu A \leq I_{RS} \leq 200\mu A$
$V_{RS} \geq 0.75V \times V_{CC}$	Standby	$ I_{RS} \leq 10\mu A$

Table 2. Transmitter and Receiver Truth Table when Not Connected to the Bus

TXD	RS	CANH	CANL	BUS STATE	RXD
Low	$V_{RS} \leq 0.75V \times V_{CC}$	High	Low	Dominant	Low
High or Float	$V_{RS} \leq 0.75V \times V_{CC}$	$V_{CC} / 2$	$V_{CC} / 2$	Recessive	High
X	$V_{RS} \geq 0.75V \times V_{CC}$	$R_{ICM} \text{ GND}$	$R_{ICM} \text{ GND}$	Recessive	High

*Common-mode input resistance.

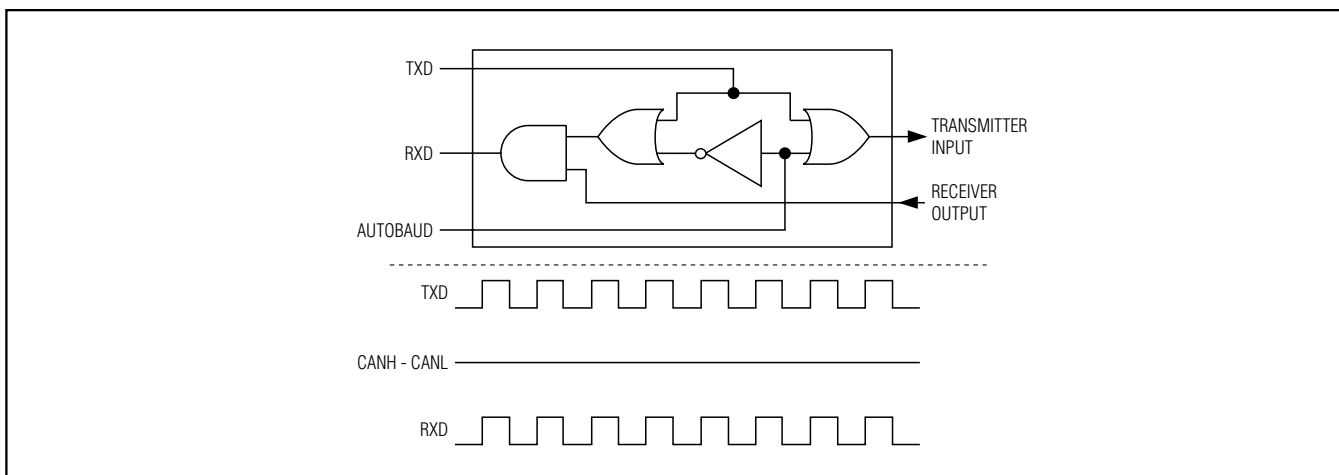

Figure 4. MAX13051 Autobaud Timing Diagram

Transmitter

The transmitter converts a single-ended input (TXD) from the CAN controller to differential outputs for the bus lines (CANH, CANL). The truth table for the transmitter and receiver is given in Table 2.

TXD Dominant Timeout

The MAX13051 provides a transmitter-dominant timeout that prevents erroneous CAN controllers from clamping the bus to a dominant level by maintaining a continuous low TXD signal. When the TXD remains in the dominant state for greater than 1ms (max), the transmitter becomes disabled, driving the bus line to a recessive state (Figure 5). After a dominant timeout fault, the

MAX13051's transmitter becomes enabled upon detecting a rising edge at TXD.

Receiver

The receiver reads differential inputs from the bus lines (CANH, CANL) and transfers this data as a single-ended output (RXD) to the CAN controller. It consists of a comparator that senses the difference, $V_{DIFF} = (CANH - CANL)$, with respect to an internal threshold of 0.7V. If this difference is positive, ($V_{DIFF} > 0.9V$), a logic-low is present at RXD. If negative, ($V_{DIFF} < 0.5V$), a logic-high is present. The receiver always echoes the CAN bus data when not operating in autobaud mode.

MAX13051

±80V Fault-Protected Can Transceiver with Autobaud

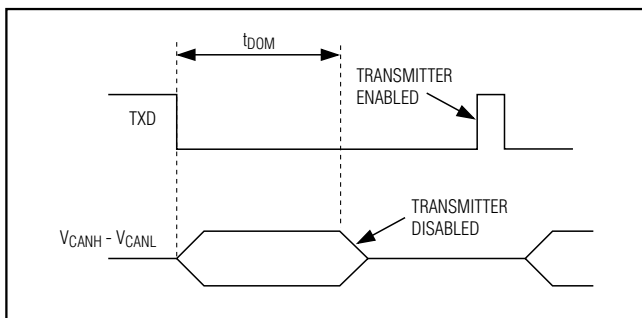

Figure 5. Transmitter-Dominant Timeout Timing Diagram

The CANH and CANL common-mode range is $\pm 12V$ exceeding the ISO 11898 specification at $-2V$ to $+7V$. RXD is logic-high when CANH and CANL are shorted or undriven.

Driver Output Protection

The MAX13051 current-limiting feature protects the transmitter output stage against a short circuit to a positive and negative battery voltage. Although the power dissipation increases during this fault condition, current-limit protection prevents destruction of the transmitter output stage. Upon removal of a short, the MAX13051 resumes normal operation.

Thermal Shutdown

If the junction temperature exceeds $+165^{\circ}C$, the device is switched off. The hysteresis is approximately $13^{\circ}C$, disabling thermal shutdown once the temperature drops below $152^{\circ}C$. In thermal shutdown, CANH and CANL go recessive. After a thermal-shutdown event, the MAX13051 resumes normal operation when the

junction temperature drops below the thermal-shutdown hysteresis, and upon the MAX13051 detecting a rising edge at TXD.

Applications Information

Reduced EMI and Reflections

In slope-control mode, the CANH and CANL outputs are slew-rate limited, minimizing high-frequency EMI, and reducing reflections caused by improperly terminated cables.

In multidrop CAN applications, it is important to maintain a direct point-to-point wiring scheme. A single pair of wires should connect each element of the CAN bus, and the two ends of the bus should be terminated with 120Ω resistors, see Figure 6. A star configuration should never be used.

Any deviation from the point-to-point wiring scheme creates a stub. The high-speed edge of the CAN data on a stub can create reflections back down the bus. These reflections can cause data errors by eroding the noise margin of the system.

Although stubs are unavoidable in a multidrop system, care should be taken to keep these stubs as small as possible, especially in high-speed mode. In slope-control mode, the requirements are not as rigorous, but stub length should still be minimized.

Layout Consideration

CANH and CANL are differential signals and steps should be taken to insure equivalent parasitic capacitance. Place the resistor at RS as close as possible to the MAX13051 to minimize any possible noise coupling at the input.

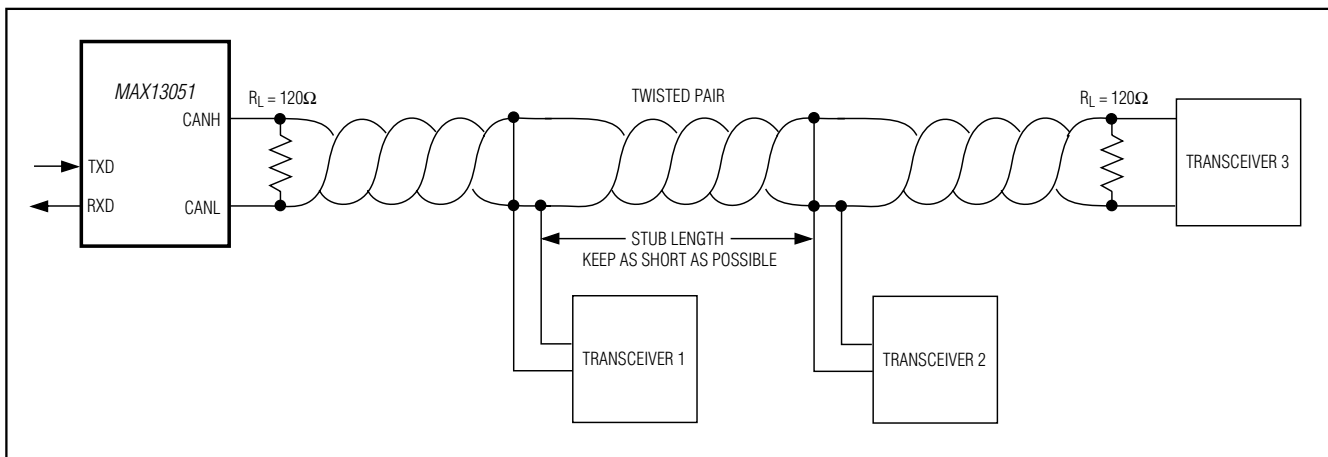

Figure 6. Multiple Receivers Connected to CAN Bus

MAX13051

±80V Fault-Protected Can Transceiver with Autobaud

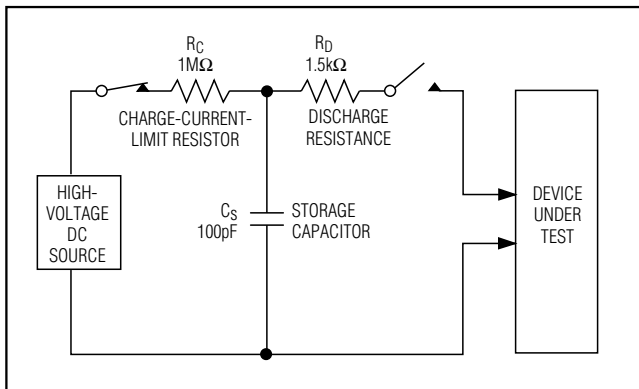

Figure 7. Human Body ESD Test Model

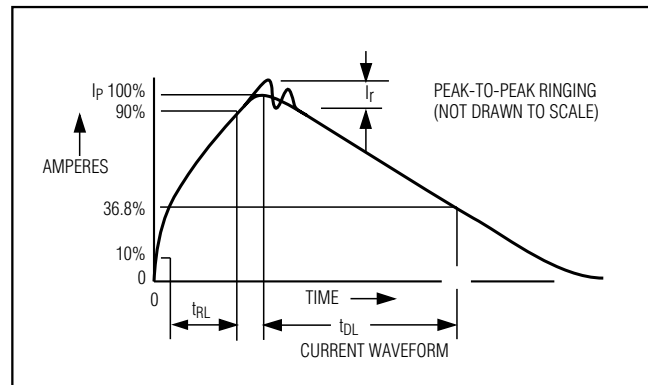

Figure 8. Human Body Model Current Waveform

Power Supply and Bypassing

The MAX13051 requires no special layout considerations beyond common practices. Bypass V_{CC} to GND with a 0.1 μ F ceramic capacitor mounted closely to the IC with short lead lengths and wide trace widths.

±6kV ESD Protection

ESD protection structures are incorporated on all inputs to protect against ESD encountered during handling and assembly. CANH and CANL inputs have extra protection to protect against static electricity found in normal operation. Maxim's engineers have developed state-of-the-art structures to protect these pins (CANH, CANL) against ±6kV ESD without damage. ESD protection can be tested in several ways. The CANH and CANL inputs are characterized for protection to ±6kV using the Human Body Model.

ESD Test Conditions

ESD performance depends on a number of conditions. Contact Maxim for a reliability report that documents test setup, methodology, and results.

Human Body Model

Figure 7 shows the Human Body Model, and Figure 8 shows the current waveform it generates when discharged into a low impedance. This model consists of a 100pF capacitor charged to the ESD voltage of interest, which is then discharged into the device through a 1.5k Ω resistor.

Chip Information

PROCESS: BiCMOS

Package Information

For the latest package outline information and land patterns (footprints), go to www.maximintegrated.com/packages. Note that a "+", "#", or "-" in the package code indicates RoHS status only. Package drawings may show a different suffix character, but the drawing pertains to the package regardless of RoHS status.

PACKAGE TYPE	PACKAGE CODE	OUTLINE NO.	LAND PATTERN NO.
8 SO	S8M+5	21-0041	90-0096

MAX13051

±80V Fault-Protected Can Transceiver with Autobaud

Revision History

REVISION NUMBER	REVISION DATE	DESCRIPTION	PAGES CHANGED
0	11/04	Initial Release	—
1	10/12	Added lead-free package information to the data sheet	1



Maxim Integrated cannot assume responsibility for use of any circuitry other than circuitry entirely embodied in a Maxim Integrated product. No circuit patent licenses are implied. Maxim Integrated reserves the right to change the circuitry and specifications without notice at any time. The parametric values (min and max limits) shown in the Electrical Characteristics table are guaranteed. Other parametric values quoted in this data sheet are provided for guidance.

Looking for pricing, stock, or lifecycle information?

Click below to explore more details on WIN SOURCE:

- ⊖ [View MAX13051ESA+ on WIN SOURCE](#)
- ⊖ [Maxim Integrated Information](#)

Optimize Your Supply Chain with WIN SOURCE Solutions

- ✓ Global Sourcing Solution
- ✓ Obsolete Management
- ✓ Cost Control Management
- ✓ Shortage Management
- ✓ Alternative Solution
- ✓ Excess Inventory Management