



**THE DATASHEET OF  
AOK20B135D1**



### General Description

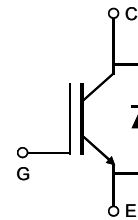
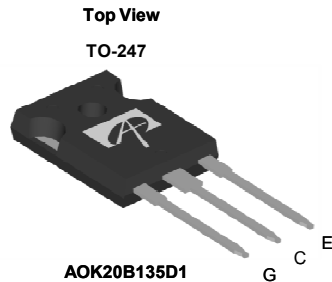
- Latest AlphaIGBT ( $\alpha$ IGBT) technology
- Best in Class  $V_{CE(SAT)}$  enables high efficiencies
- Low turn-off switching loss due to fast turn-off time
- Very smooth turn-off current waveforms reduce EMI
- Better thermal management
- High surge current capability
- Minimal gate spike due to high input capacitance

### Applications

- Induction Cooking
- Rice Cookers
- Microwave Ovens
- Other soft switching applications

### Product Summary

$V_{CE}$	1350V
$I_C$ ( $T_C=100^\circ\text{C}$ )	20A
$V_{CE(sat)}$ ( $T_C=25^\circ\text{C}$ )	1.57V



Orderable Part Number	Package Type	Form	Minimum Order Quantity
AOK20B135D1	TO247	Tube	240

### Absolute Maximum Ratings $T_A=25^\circ\text{C}$ unless otherwise noted

Parameter	Symbol	AOK20B135D1	Units
Collector-Emitter Voltage	$V_{CE}$	1350	V
Gate-Emitter Voltage	$V_{GE}$	$\pm 20$	V
Transient Voltage ( $t_p \leq 1\mu\text{s}, D < 0.025$ )		$\pm 30$	
Continuous Collector Current	$I_C$	$T_C=25^\circ\text{C}$	40
Current		$T_C=100^\circ\text{C}$	20
Pulsed Collector Current, Limited by $T_{Jmax}$	$I_{Cpulse}$	80	A
Turn off SOA, $V_{CE} \leq 600\text{V}$ , Limited by $T_{Jmax}$	$I_{LM}$	80	A
Continuous Diode Forward Current	$I_F$	$T_C=25^\circ\text{C}$	40
		$T_C=100^\circ\text{C}$	20
Diode Pulsed Current, Limited by $T_{Jmax}$	$I_{Fpulse}$	80	A
Power Dissipation	$P_D$	$T_C=25^\circ\text{C}$	340
		$T_C=100^\circ\text{C}$	170
Junction and Storage Temperature Range	$T_J, T_{STG}$	-55 to 175	$^\circ\text{C}$
Maximum lead temperature for soldering purpose, 1/8" from case for 5 seconds	$T_L$	300	$^\circ\text{C}$

### Thermal Characteristics

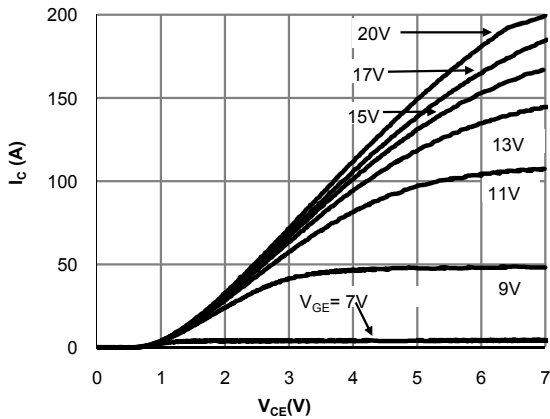
Parameter	Symbol	AOK20B135D1	Units
Maximum Junction-to-Ambient	$R_{\theta JA}$	40	$^\circ\text{C/W}$
Maximum IGBT Junction-to-Case	$R_{\theta JC}$	0.44	$^\circ\text{C/W}$
Maximum Diode Junction-to-Case	$R_{\theta JC}$	1.20	$^\circ\text{C/W}$

**Electrical Characteristics (T<sub>J</sub>=25°C unless otherwise noted)**

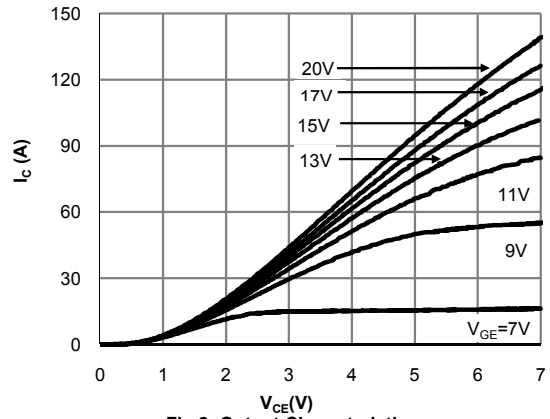
Symbol	Parameter	Conditions	Min	Typ	Max	Units	
<b>STATIC PARAMETERS</b>							
$BV_{CES}$	Collector-Emitter Breakdown Voltage	$I_C=1mA, V_{GE}=0V, T_J=25^\circ C$	1350	-	-	V	
$V_{CE(sat)}$	Collector-Emitter Saturation Voltage	$V_{GE}=15V, I_C=20A$	$T_J=25^\circ C$	-	1.57	1.8	V
			$T_J=125^\circ C$	-	1.86	-	
			$T_J=175^\circ C$	-	2	-	
$V_F$	Diode Forward Voltage	$V_{GE}=0V, I_C=20A$	$T_J=25^\circ C$	-	1.46	1.8	V
			$T_J=125^\circ C$	-	1.51	-	
			$T_J=175^\circ C$	-	1.52	-	
$V_{GE(th)}$	Gate-Emitter Threshold Voltage	$V_{CE}=5V, I_C=1mA$	4.7	5.3	5.9	V	
$I_{CES}$	Zero Gate Voltage Collector Current	$V_{CE}=1350V, V_{GE}=0V$	$T_J=25^\circ C$	-	-	10	$\mu A$
			$T_J=125^\circ C$	-	-	800	
			$T_J=175^\circ C$	-	-	8000	
$I_{GES}$	Gate-Emitter leakage current	$V_{CE}=0V, V_{GE}=\pm 20V$	-	-	$\pm 100$	nA	
$g_{FS}$	Forward Transconductance	$V_{CE}=20V, I_C=20A$	-	21	-	S	
<b>DYNAMIC PARAMETERS</b>							
$C_{ies}$	Input Capacitance	$V_{GE}=0V, V_{CE}=25V, f=1MHz$	-	1900	-	pF	
$C_{oes}$	Output Capacitance		-	107	-	pF	
$C_{res}$	Reverse Transfer Capacitance		-	32	-	pF	
$Q_g$	Total Gate Charge	$V_{GE}=15V, V_{CE}=1080V, I_C=20A$	-	66	-	nC	
$Q_{ge}$	Gate to Emitter Charge		-	14	-	nC	
$Q_{gc}$	Gate to Collector Charge		-	31.5	-	nC	
$R_g$	Gate resistance	$V_{GE}=0V, V_{CE}=0V, f=1MHz$	-	1.63	-	$\Omega$	
<b>SWITCHING PARAMETERS, (Load Inductive, T<sub>J</sub>=25°C)</b>							
$t_{D(off)}$	Turn-Off Delay Time	$T_J=25^\circ C$ $V_{GE}=15V, V_{CE}=600V, I_C=20A,$ $R_G=15\Omega,$ Parasitic Inductance=150nH	-	156	-	ns	
$t_f$	Turn-Off Fall Time		-	150	-	ns	
$E_{off}$	Turn-Off Energy		-	1.05	-	mJ	
<b>SWITCHING PARAMETERS, (Load Inductive, T<sub>J</sub>=175°C)</b>							
$t_{D(off)}$	Turn-Off Delay Time	$T_J=150^\circ C$ $V_{GE}=15V, V_{CE}=600V, I_C=20A,$ $R_G=15\Omega,$ Parasitic Inductance=150nH	-	180	-	ns	
$t_f$	Turn-Off Fall Time		-	300	-	ns	
$E_{off}$	Turn-Off Energy		-	1.76	-	mJ	

THIS PRODUCT HAS BEEN DESIGNED AND QUALIFIED FOR THE CONSUMER MARKET. APPLICATIONS OR USES AS CRITICAL COMPONENTS IN LIFE SUPPORT DEVICES OR SYSTEMS ARE NOT AUTHORIZED. AOS DOES NOT ASSUME ANY LIABILITY ARISING OUT OF SUCH APPLICATIONS OR USES OF ITS PRODUCTS. AOS RESERVES THE RIGHT TO IMPROVE PRODUCT DESIGN, FUNCTIONS AND RELIABILITY WITHOUT NOTICE.

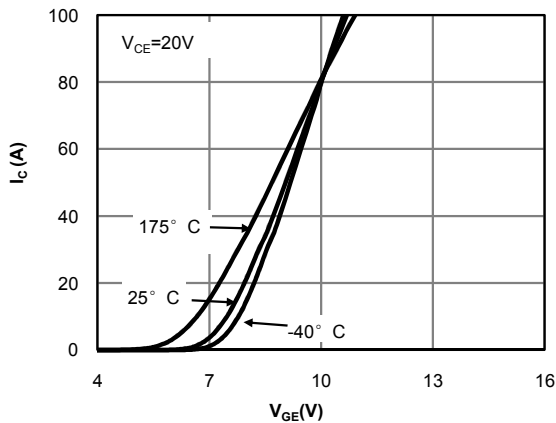
**TYPICAL ELECTRICAL AND THERMAL CHARACTERISTICS**



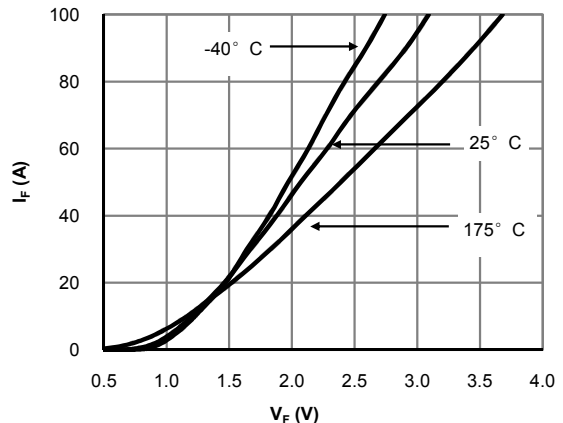
**Fig 1: Output Characteristic**  
( $T_j=25^\circ\text{C}$ )



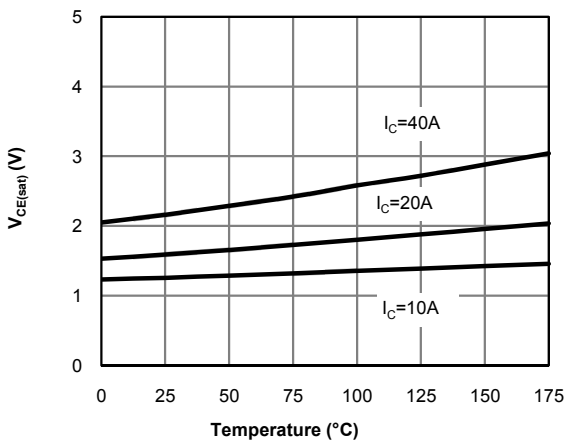
**Fig 2: Output Characteristic**  
( $T_j=175^\circ\text{C}$ )



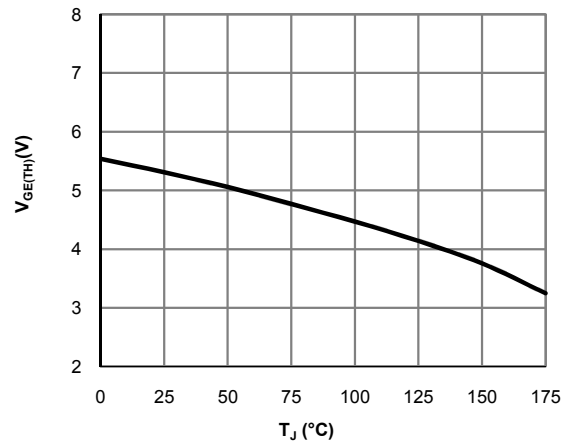
**Fig 3: Transfer Characteristic**



**Fig 4: Diode Characteristic**

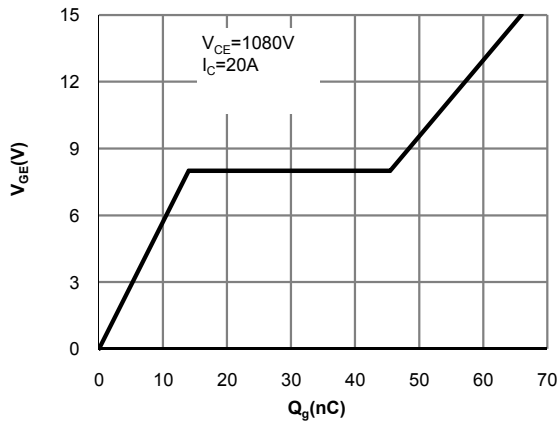


**Fig 5: Collector-Emitter Saturation Voltage vs. Junction Temperature**

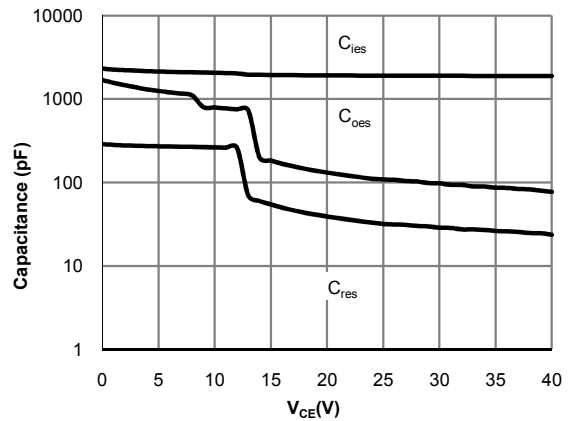


**Figure 6:  $V_{GE(TH)}$  vs.  $T_j$**

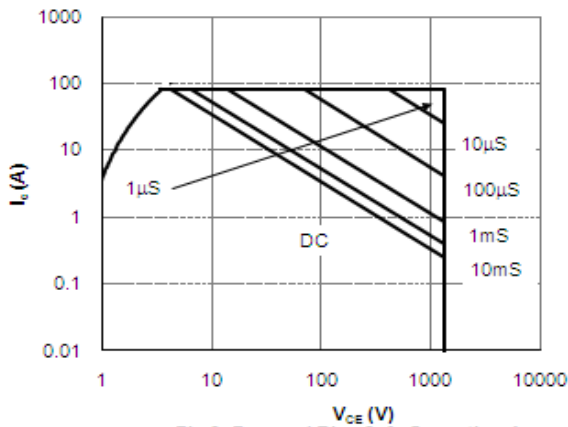
**TYPICAL ELECTRICAL AND THERMAL CHARACTERISTICS**



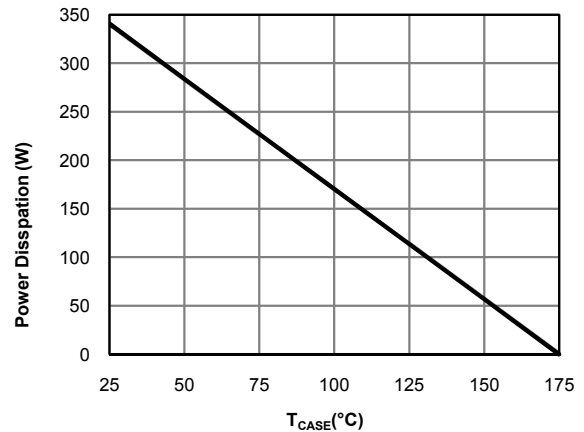
**Fig 7: Gate-Charge Characteristics**



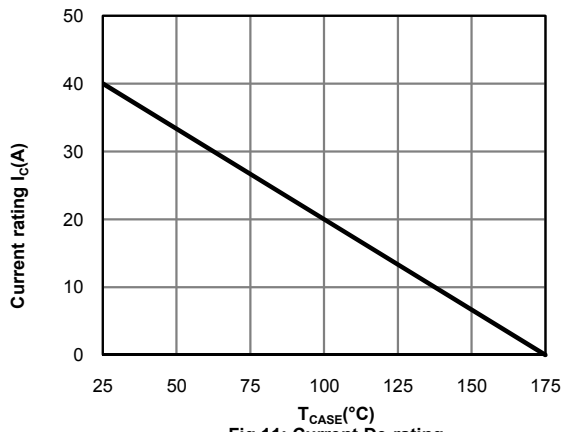
**Fig 8: Capacitance Characteristic**



**Fig 9: Forward Bias Safe Operating Area**  
( $T_C=25^\circ\text{C}, V_{GE}=15\text{V}$ )

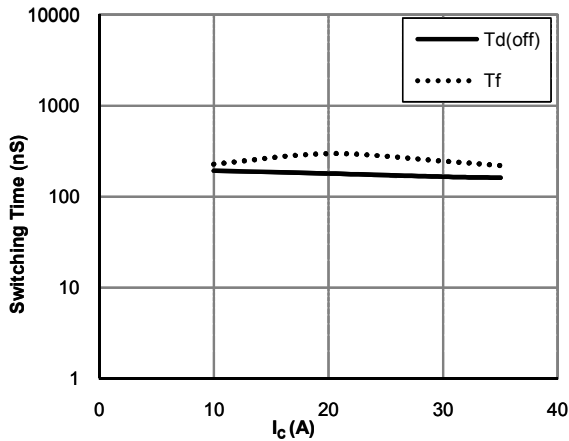


**Fig 10: Power Dissipation as a Function of Case**

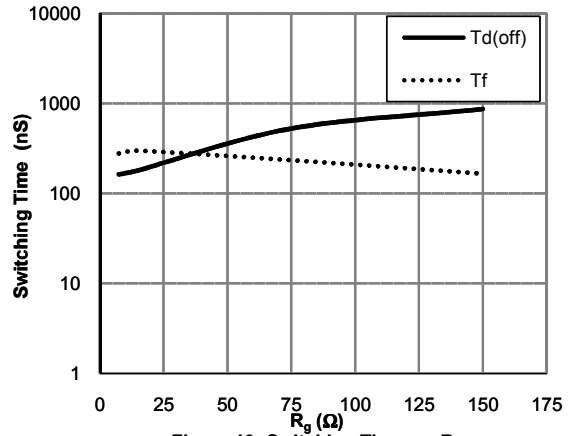


**Fig 11: Current De-rating**

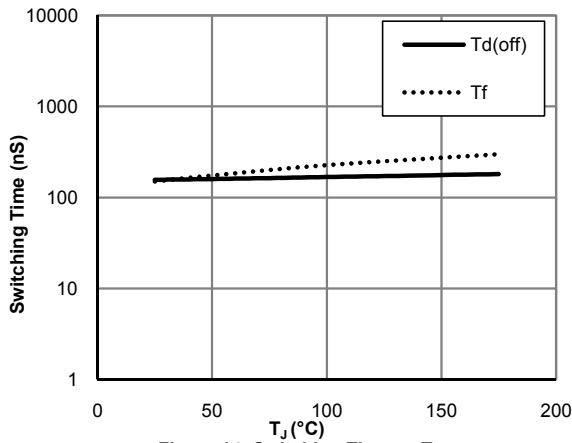
**TYPICAL ELECTRICAL AND THERMAL CHARACTERISTICS**



**Figure 12: Switching Time vs.  $I_c$**   
( $T_J=175^\circ\text{C}, V_{GE}=15\text{V}, V_{CE}=600\text{V}, R_g=15\Omega$ )

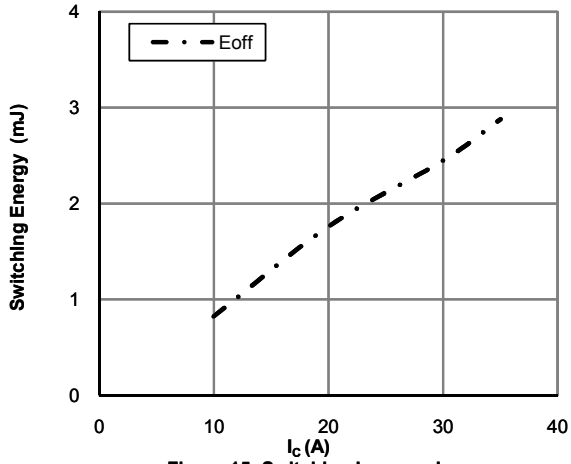


**Figure 13: Switching Time vs.  $R_g$**   
( $T_J=175^\circ\text{C}, V_{GE}=15\text{V}, V_{CE}=600\text{V}, I_c=20\text{A}$ )

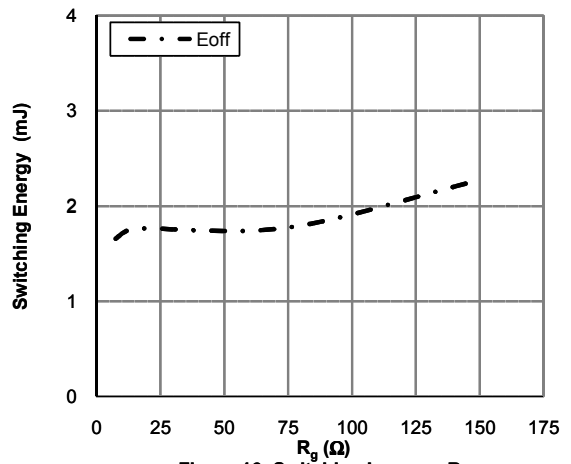


**Figure 14: Switching Time vs.  $T_J$**   
( $V_{GE}=15\text{V}, V_{CE}=600\text{V}, I_c=20\text{A}, R_g=15\Omega$ )

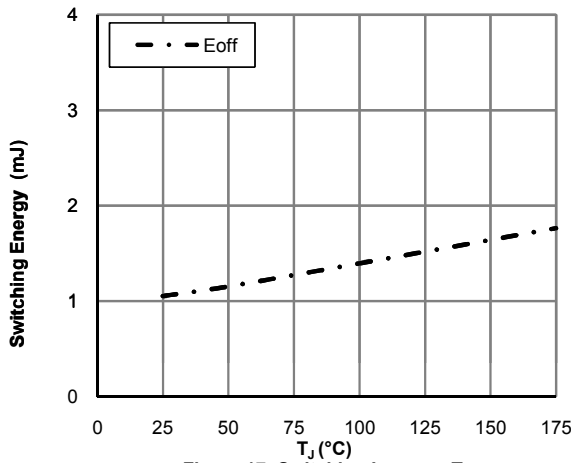
**TYPICAL ELECTRICAL AND THERMAL CHARACTERISTICS**



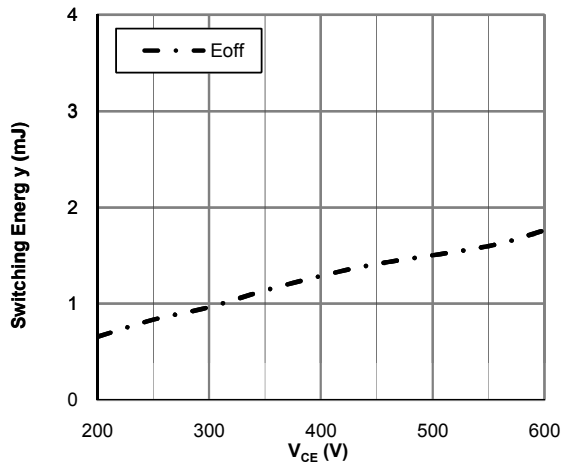
**Figure 15: Switching Loss vs.  $I_C$**   
( $T_J=175^\circ\text{C}, V_{GE}=15\text{V}, V_{CE}=600\text{V}, R_g=15\Omega$ )



**Figure 16: Switching Loss vs.  $R_g$**   
( $T_J=175^\circ\text{C}, V_{GE}=15\text{V}, V_{CE}=600\text{V}, I_C=20\text{A}$ )

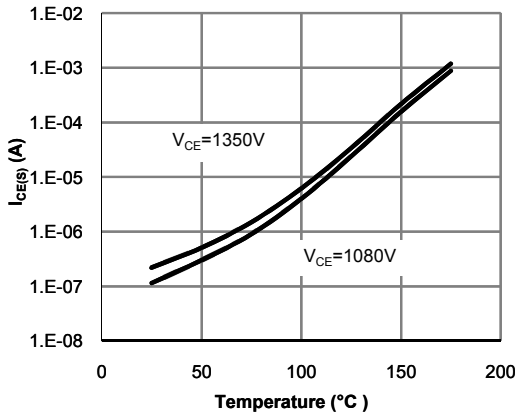


**Figure 17: Switching Loss vs.  $T_J$**   
( $V_{GE}=15\text{V}, V_{CE}=600\text{V}, I_C=20\text{A}, R_g=15\Omega$ )

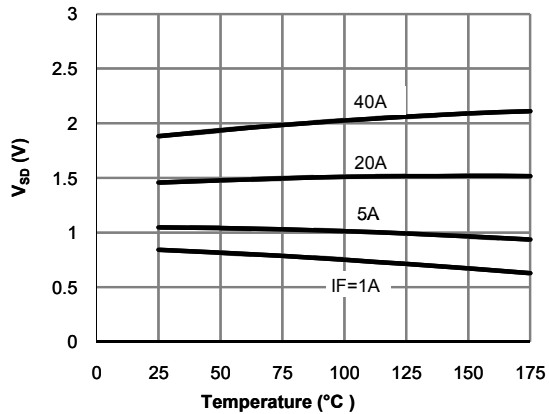


**Figure 18: Switching Loss vs.  $V_{CE}$**   
( $T_J=175^\circ\text{C}, V_{GE}=15\text{V}, I_C=20\text{A}, R_g=15\Omega$ )

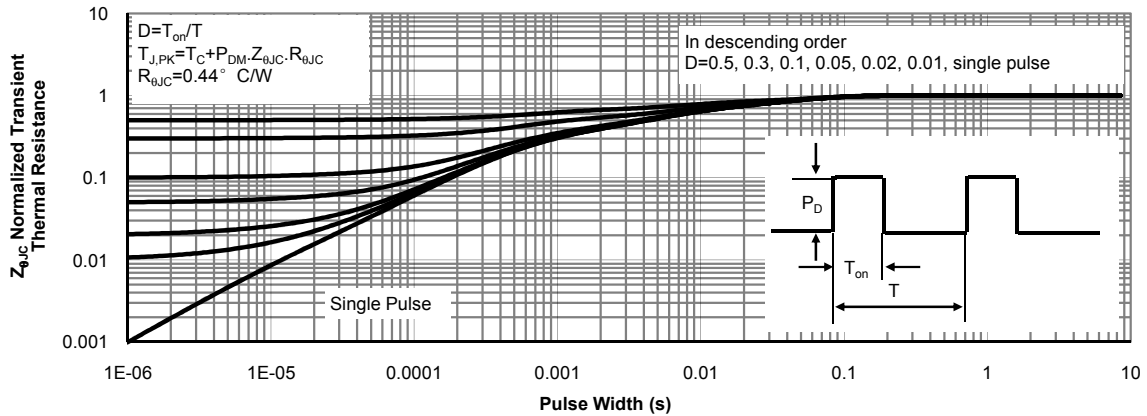
**TYPICAL ELECTRICAL AND THERMAL CHARACTERISTICS**



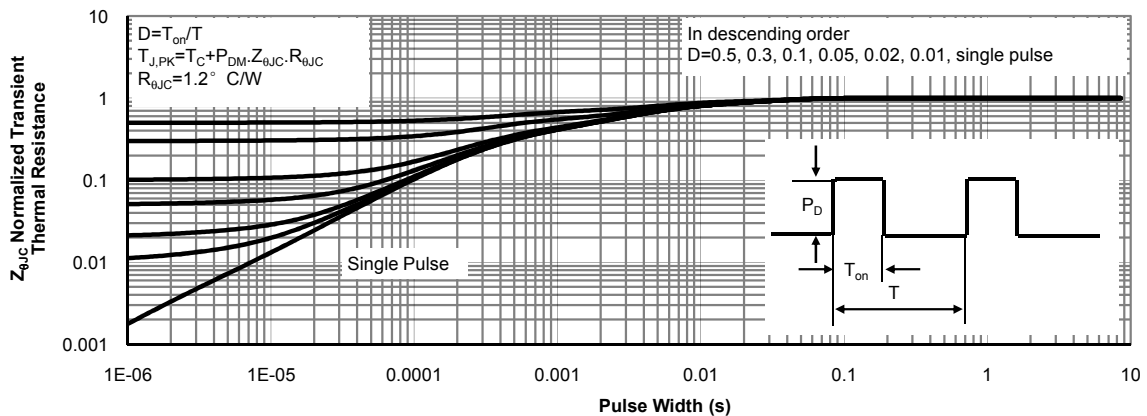
**Fig 19: Diode Reverse Leakage Current vs. Junction Temperature**



**Fig 20: Diode Forward Voltage vs. Junction Temperature**

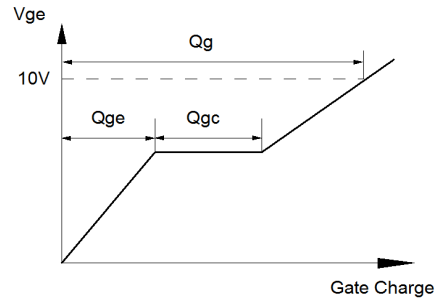
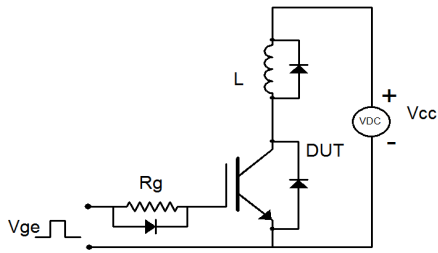


**Figure 21: Normalized Maximum Transient Thermal Impedance for IGBT**

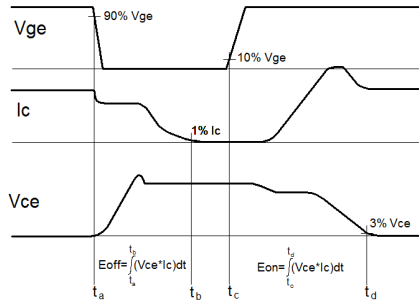
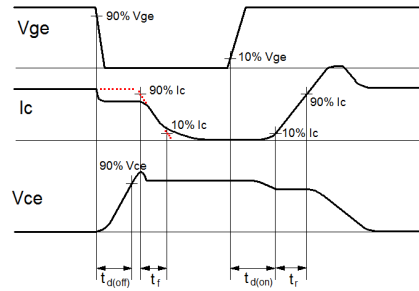
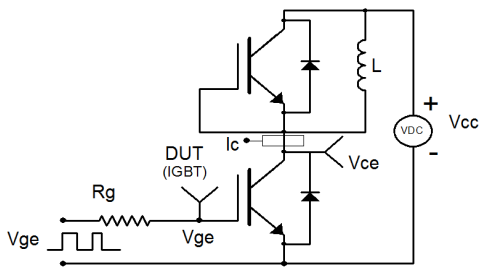


**Figure 22: Normalized Maximum Transient Thermal Impedance for Diode**

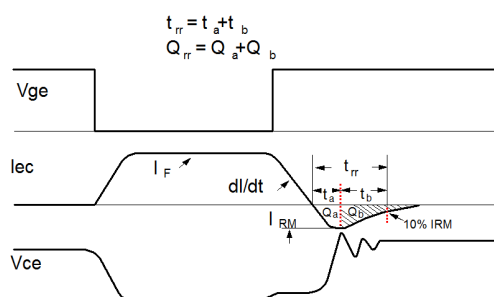
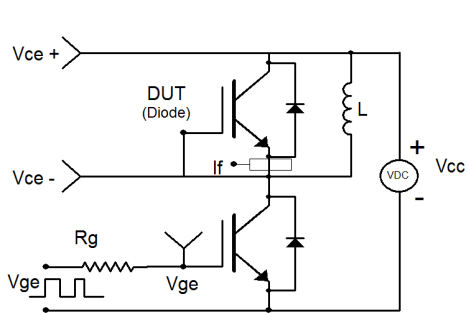
Gate Charge Test Circuit & Waveform



Inductive Switching Test Circuit & Waveforms



Diode Recovery Test Circuit & Waveforms



## Looking for pricing, stock, or lifecycle information?

Click below to explore more details on WIN SOURCE:

- ⊖ [View AOK20B135D1 on WIN SOURCE](#)
- ⊖ [Alpha & Omega Semiconductor Inc. Information](#)

## Optimize Your Supply Chain with WIN SOURCE Solutions

- ✓ Global Sourcing Solution
- ✓ Obsolete Management
- ✓ Cost Control Management
- ✓ Shortage Management
- ✓ Alternative Solution
- ✓ Excess Inventory Management