

74ABT2240

Octal inverting buffer with 30 Ω series termination resistors;
3-state

Rev. 04 — 17 January 2005

Product data sheet

1. General description

The 74ABT2240 high performance BiCMOS device combines low static and dynamic power dissipation with high speed.

The 74ABT2240 device is an octal inverting buffer that is ideal for driving bus lines. The device features two output enable inputs ($1\overline{OE}$ and $2\overline{OE}$), each controlling four of the 3-state outputs.

The 74ABT2240 is designed with 30 Ω series resistance in both the HIGH and LOW states of the output. This design reduces line noise in applications such as memory address drivers, clock drivers and bus receivers/transmitters.

The 74ABT2240 is the same as the 74ABT240. The part number has been changed to reflect industry standards.

2. Features

- Octal bus interface
- 3-state buffers
- Live insertion and extraction permitted
- Outputs include series resistance of 30 Ω , making external termination resistors unnecessary
- Output capability: +12 mA and -32 mA
- Latch-up protection:
 - ◆ JESD78: exceeds 500 mA
- ESD protection:
 - ◆ MIL STD 883 method 3015: exceeds 2000 V
 - ◆ Machine model: exceeds 200 V
- Power-up 3-state
- Same part as 74ABT240

PHILIPS

3. Quick reference data

Table 1: Quick reference data

$GND = 0\text{ V}$; $T_{amb} = 25\text{ }^\circ\text{C}$.

Symbol	Parameter	Conditions	Min	Typ	Max	Unit
t_{PLH}	propagation delay nAn to n \bar{Y} n	$C_L = 50\text{ pF}$; $V_{CC} = 5\text{ V}$	-	2.8	-	ns
t_{PHL}	propagation delay nAn to n \bar{Y} n	$C_L = 50\text{ pF}$; $V_{CC} = 5\text{ V}$	-	4.3	-	ns
C_I	input capacitance	$V_I = 0\text{ V}$ or V_{CC}	-	3	-	pF
C_O	output capacitance	outputs disabled; $V_O = 0\text{ V}$ or V_{CC}	-	7	-	pF
I_{CC}	quiescent supply current	outputs 3-state; $V_{CC} = 5\text{ V}$	-	50	-	μA

4. Ordering information

Table 2: Ordering information

Type number	Package			
	Temperature range	Name	Description	Version
74ABT2240N	-40 $^\circ\text{C}$ to +85 $^\circ\text{C}$	DIP20	plastic dual in-line package; 20 leads (300 mil)	SOT146-1
74ABT2240D	-40 $^\circ\text{C}$ to +85 $^\circ\text{C}$	S020	plastic small outline package; 20 leads; body width 7.5 mm	SOT163-1
74ABT2240PW	-40 $^\circ\text{C}$ to +85 $^\circ\text{C}$	TSSOP20	plastic thin shrink small outline package; 20 leads; body width 4.4 mm	SOT360-1

5. Functional diagram

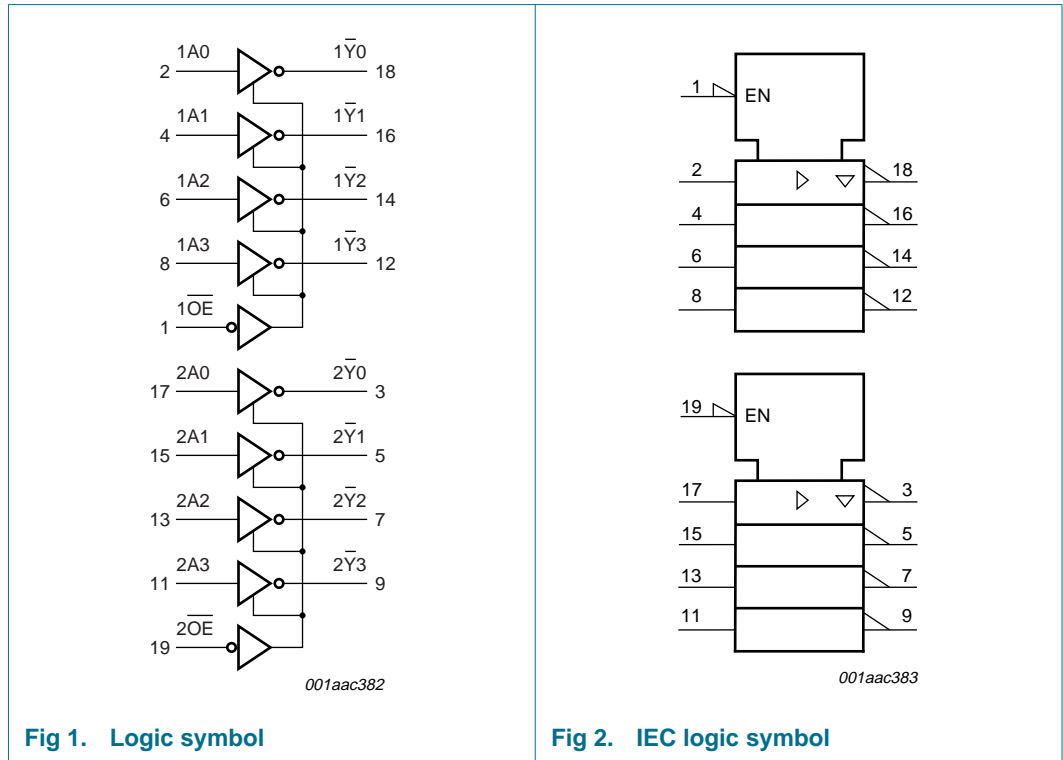

Fig 1. Logic symbol

Fig 2. IEC logic symbol

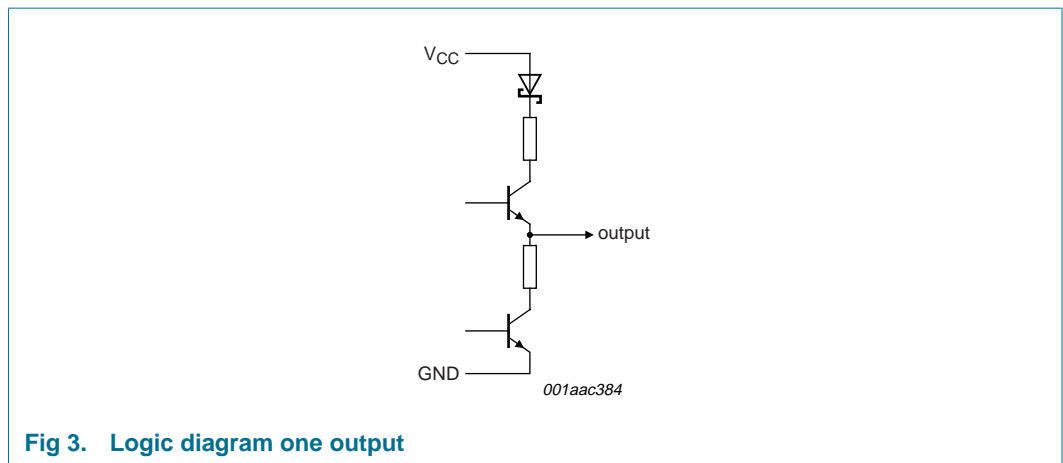

Fig 3. Logic diagram one output

6. Pinning information

6.1 Pinning

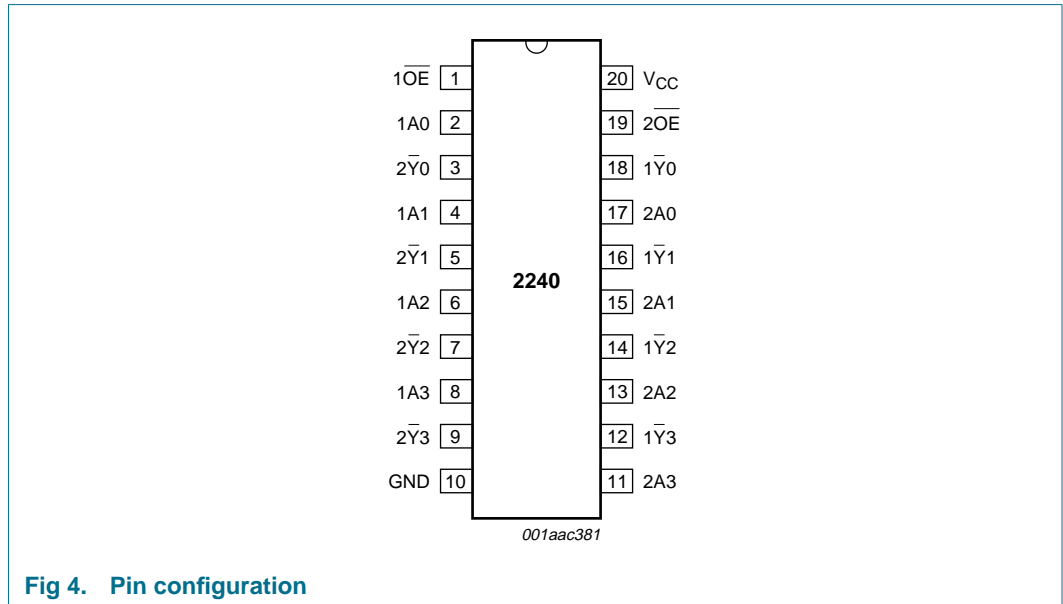

Fig 4. Pin configuration

6.2 Pin description

Table 3: Pin description

Symbol	Pin	Description
1OE	1	outputs 1 enable control input
1A0	2	data input
2Y0	3	data output
1A1	4	data input
2Y1	5	data output
1A2	6	data input
2Y2	7	data output
1A3	8	data input
2Y3	9	data output
GND	10	ground (0 V)
2A3	11	data input
1Y3	12	data output
2A2	13	data input
1Y2	14	data output
2A1	15	data input
1Y1	16	data output
2A0	17	data input

Table 3: Pin description ...continued

Symbol	Pin	Description
$1\bar{Y}0$	18	data output
$2\bar{OE}$	19	outputs 2 enable control input
V_{CC}	20	supply voltage

7. Functional description

7.1 Function table

Table 4: Function table [1]

Control input	Input	Output
$n\bar{OE}$	nA_n	$n\bar{Y}_n$
L	L	H
L	H	L
H	X	Z

- [1] H = HIGH voltage;
L = LOW voltage;
X = don't care;
Z = high-impedance OFF-state.

8. Limiting values

Table 5: Limiting values

In accordance with the Absolute Maximum Rating System (IEC 60134).

Symbol	Parameter	Conditions	Min	Max	Unit
V_{CC}	supply voltage		-0.5	+7.0	V
V_I	input voltage		[1] -1.2	+7.0	V
V_O	output voltage	output in OFF-state or HIGH-state	[1] -0.5	+5.5	V
I_{IK}	input diode current	$V_I < 0$ V	-18	-	mA
I_{OK}	output diode current	$V_O < 0$ V	-50	-	mA
I_O	output current	output in LOW-state	-	128	mA
T_j	junction temperature		[2] -	150	$^{\circ}$ C
T_{stg}	storage temperature		-65	+150	$^{\circ}$ C

[1] The input and output voltage ratings may be exceeded if the input and output current ratings are observed.

[2] The performance capability of a high-performance integrated circuit in conjunction with its thermal environment can create junction temperatures which are detrimental to reliability. The maximum junction temperature of this integrated circuit should not exceed 150 $^{\circ}$ C.

9. Recommended operating conditions

Table 6: Recommended operating conditions

Symbol	Parameter	Conditions	Min	Typ	Max	Unit
V_{CC}	supply voltage		4.5	-	5.5	V
V_I	input voltage		0	-	V_{CC}	V
V_{IH}	HIGH-level input voltage		2.0	-	-	V
V_{IL}	LOW-level input voltage		-	-	0.8	V
I_{OH}	HIGH-level output current		-	-	-32	mA
I_{OL}	LOW-level output current		-	-	12	mA
$\Delta t/\Delta V$	input transition rise or fall rate		0	-	10	ns/V
T_{amb}	ambient temperature	in free air	-40	-	+85	$^{\circ}$ C

10. Static characteristics

Table 7: Static characteristics

At recommended operating conditions; voltages are referenced to GND (ground = 0 V).

Symbol	Parameter	Conditions	Min	Typ	Max	Unit	
T_{amb} = 25 °C							
V _{IK}	input diode voltage	V _{CC} = 4.5 V; I _{IK} = -18 mA	-	-0.9	-1.2	V	
V _{OH}	HIGH-level output voltage	V _{CC} = 4.5 V; V _I = V _{IL} or V _{IH}					
		I _{OH} = -3 mA	2.5	2.9	-	V	
		I _{OH} = -32 mA	2.0	2.4	-	V	
		V _{CC} = 5.0 V; V _I = V _{IL} or V _{IH}					
V _{OL}	LOW-level output voltage	I _{OH} = -3 mA	3.0	3.4	-	V	
		I _{OH} = -32 mA					
V _{OL}	LOW-level output voltage	V _{CC} = 4.5 V; V _I = V _{IL} or V _{IH}					
		I _{OL} = 5 mA	-	0.32	0.55	V	
		I _{OL} = 12 mA	-	-	0.8	V	
I _{LI}	input leakage current	V _{CC} = 5.5 V; V _I = GND or 5.5 V	-	±0.01	±1.0	μA	
I _{OFF}	power-off leakage current	V _{CC} = 0 V; V _O or V _I 4.5 V	-	±5.0	±100	μA	
I _{PU} , I _{PD}	power-up or power-down down 3-state output current	V _{CC} = 2.1 V; V _O = 0.5 V; V _I = GND or V _{CC} ; V _{nOE} = don't care	[1]	±5.0	±50	μA	
I _{OZ}	3-state output current	V _{CC} = 5.5 V; V _I = V _{IL} or V _{IH}					
		output HIGH-state at V _O = 2.7 V	-	0.01	50	μA	
		output LOW-state at V _O = 0.5 V	-	-0.01	-50	μA	
I _{CEX}	output HIGH-state leakage current	V _{CC} = 5.5 V; V _O = 5.5 V; V _I = GND or V _{CC}	-	5.0	50	μA	
I _O	output current	V _{CC} = 5.5 V; V _O = 2.5 V	[2]	-50	-100	-180	mA
I _{CC}	quiescent supply current	V _{CC} = 5.5 V; V _I = GND or V _{CC}					
		outputs HIGH-state	-	50	250	μA	
		outputs LOW-state	-	24	30	mA	
		outputs 3-state	-	50	250	μA	
ΔI _{CC}	additional supply current						
		per data input pin	one data input at 3.4 V and other inputs at V _{CC} or GND; V _{CC} = 5.5 V	[3]			
			outputs enabled	-	0.5	1.5	mA
			outputs 3-state	-	0.5	1.5	mA
		per enable input pin	one enable input at 3.4 V and other inputs at V _{CC} or GND; V _{CC} = 5.5 V	[3]			
		outputs 3-state	-	0.5	1.5	mA	
C _I	input capacitance	V _I = 0 V or V _{CC}	-	3	-	pF	
C _O	output capacitance	outputs disabled; V _O = 0 V or V _{CC}	-	7	-	pF	

Table 7: Static characteristics ...continued

At recommended operating conditions; voltages are referenced to GND (ground = 0 V).

Symbol	Parameter	Conditions	Min	Typ	Max	Unit	
T_{amb} = -40 °C to +85 °C							
V _{IK}	input diode voltage	V _{CC} = 4.5 V; I _{IK} = -18 mA	-	-	-1.2	V	
V _{OH}	HIGH-level output voltage	V _{CC} = 4.5 V; V _I = V _{IL} or V _{IH}					
		I _{OH} = -3 mA	2.5	-	-	V	
		I _{OH} = -32 mA	2.0	-	-	V	
		V _{CC} = 5.0 V; V _I = V _{IL} or V _{IH}					
V _{OL}	LOW-level output voltage	V _{CC} = 4.5 V; V _I = V _{IL} or V _{IH}					
		I _{OL} = 5 mA	-	-	0.55	V	
		I _{OL} = 12 mA	-	-	0.8	V	
I _{LI}	input leakage current	V _{CC} = 5.5 V; V _I = GND or 5.5 V	-	-	±1.0	μA	
I _{OFF}	power-off leakage current	V _{CC} = 0.0 V; V _O or V _I ≤ 4.5 V	-	-	±100	μA	
I _{PU} , I _{PD}	power-up or power-down down 3-state output current	V _{CC} = 2.1 V; V _O = 0.5 V; V _I = GND or V _{CC} ; V _{nOE} = don't care	[1]	-	±50	μA	
I _{OZ}	3-state output current	V _{CC} = 5.5 V; V _I = V _{IL} or V _{IH}					
		output HIGH-state at V _O = 2.7 V	-	-	50	μA	
		output LOW-state at V _O = 0.5 V	-	-	-50	μA	
I _{CEX}	output HIGH-state leakage current	V _{CC} = 5.5 V; V _O = 5.5 V; V _I = GND or V _{CC}	-	-	50	μA	
I _O	output current	V _{CC} = 5.5 V; V _O = 2.5 V	[2]	-50	-	-180	mA
I _{CC}	quiescent supply current	V _{CC} = 5.5 V; V _I = GND or V _{CC}					
		outputs HIGH-state	-	-	250	μA	
		outputs LOW-state	-	-	30	mA	
		outputs 3-state	-	-	250	μA	
ΔI _{CC}	additional supply current per data input pin	one data input at 3.4 V and other inputs at V _{CC} or GND; V _{CC} = 5.5 V	[3]				
		outputs enabled	-	-	1.5	mA	
		outputs 3-state	-	-	1.5	mA	
	per enable input pin	one enable input at 3.4 V and other inputs at V _{CC} or GND; V _{CC} = 5.5 V	[3]				
		outputs 3-state	-	-	1.5	mA	

[1] This parameter is valid for any V_{CC} between 0 V and 2.1 V, with a transition time of up to 10 ms. From V_{CC} = 2.1 V to V_{CC} = 5 V ± 10 % a transition time of up to 100 μs is permitted.

[2] Not more than one output should be tested at a time, and the duration of the test should not exceed one second.

[3] This is the increase in supply current for each input at 3.4 V.

11. Dynamic characteristics

Table 8: Dynamic characteristics

$GND = 0\text{ V}$; $t_r = t_f = 2.5\text{ ns}$; $C_L = 50\text{ pF}$, $R_L = 500\text{ }\Omega$; for test circuit see [Figure 7](#).

Symbol	Parameter	Conditions	Min	Typ	Max	Unit
$T_{amb} = 25\text{ }^\circ\text{C}$						
t_{PLH}	propagation delay nAn to \overline{nYn}	$V_{CC} = 5\text{ V}$; see Figure 5	1.0	2.8	4.0	ns
t_{PHL}	propagation delay nAn to \overline{nYn}	$V_{CC} = 5\text{ V}$; see Figure 5	3.0	4.3	5.8	ns
t_{PZH}	output enable time to HIGH-level	$V_{CC} = 5\text{ V}$; see Figure 6	1.5	3.4	4.7	ns
t_{PZL}	output enable time to LOW-level	$V_{CC} = 5\text{ V}$; see Figure 6	3.5	5.5	7.6	ns
t_{PHZ}	output disable time from HIGH-level	$V_{CC} = 5\text{ V}$; see Figure 6	1.9	4.1	5.0	ns
t_{PLZ}	output disable time from LOW-level	$V_{CC} = 5\text{ V}$; see Figure 6	2.5	3.4	5.8	ns
$T_{amb} = -40\text{ }^\circ\text{C to } +85\text{ }^\circ\text{C}$						
t_{PLH}	propagation delay nAn to \overline{nYn}	$V_{CC} = 5\text{ V} \pm 0.5\text{ V}$; see Figure 5	1.0	-	4.9	ns
t_{PHL}	propagation delay nAn to \overline{nYn}	$V_{CC} = 5\text{ V} \pm 0.5\text{ V}$; see Figure 5	3.0	-	6.0	ns
t_{PZH}	output enable time to HIGH-level	$V_{CC} = 5\text{ V} \pm 0.5\text{ V}$; see Figure 6	1.5	-	5.8	ns
t_{PZL}	output enable time to LOW-level	$V_{CC} = 5\text{ V} \pm 0.5\text{ V}$; see Figure 6	3.5	-	8.4	ns
t_{PHZ}	output disable time from HIGH-level	$V_{CC} = 5\text{ V} \pm 0.5\text{ V}$; see Figure 6	1.9	-	5.6	ns
t_{PLZ}	output disable time from LOW-level	$V_{CC} = 5\text{ V} \pm 0.5\text{ V}$; see Figure 6	2.5	-	6.4	ns

12. Waveforms

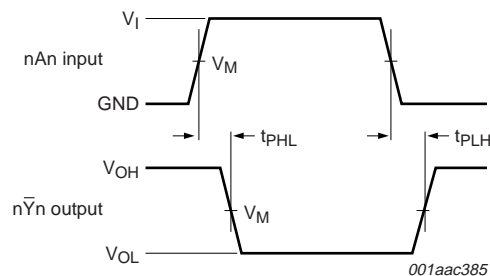

$V_M = 1.5\text{ V}$.

V_{OL} and V_{OH} are typical voltage output drop that occur with the output load.

Fig 5. Propagation delays of input (nAn) to output (\overline{nYn})

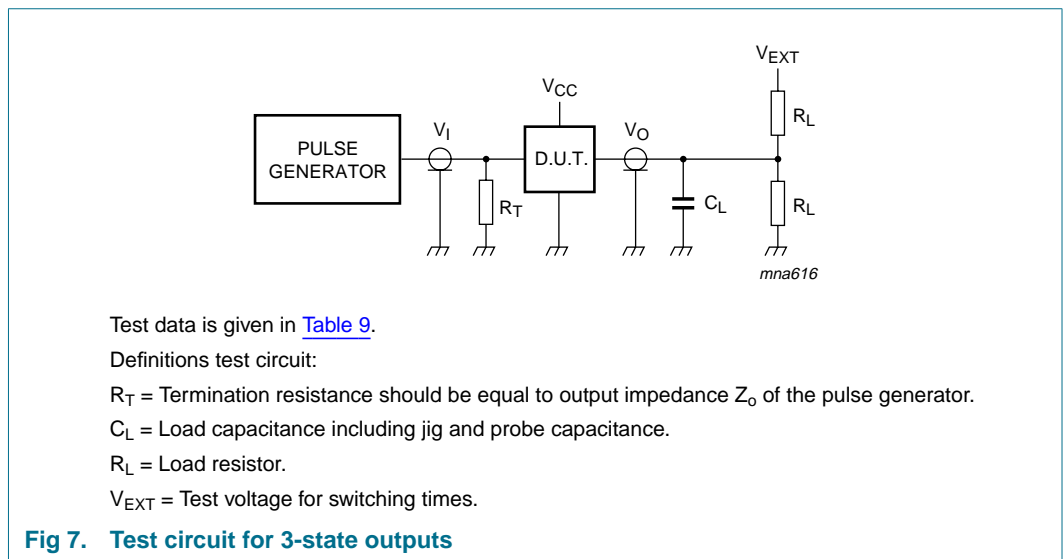
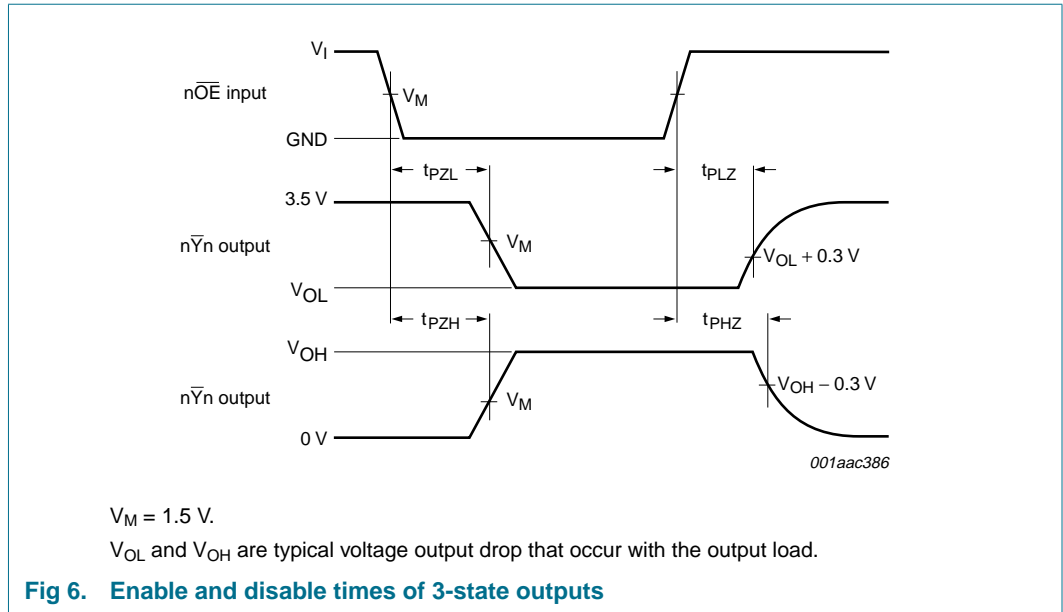

Table 9: Test data

Input		Load		V_{EXT}		
V_I	t_r, t_f	C_L	R_L	t_{PHZ}, t_{PZH}	t_{PLZ}, t_{PZL}	t_{PLH}, t_{PHL}
3 V	2.5 ns	50 pF	500 Ω	open	7 V	open

13. Package outline

DIP20: plastic dual in-line package; 20 leads (300 mil)

SOT146-1

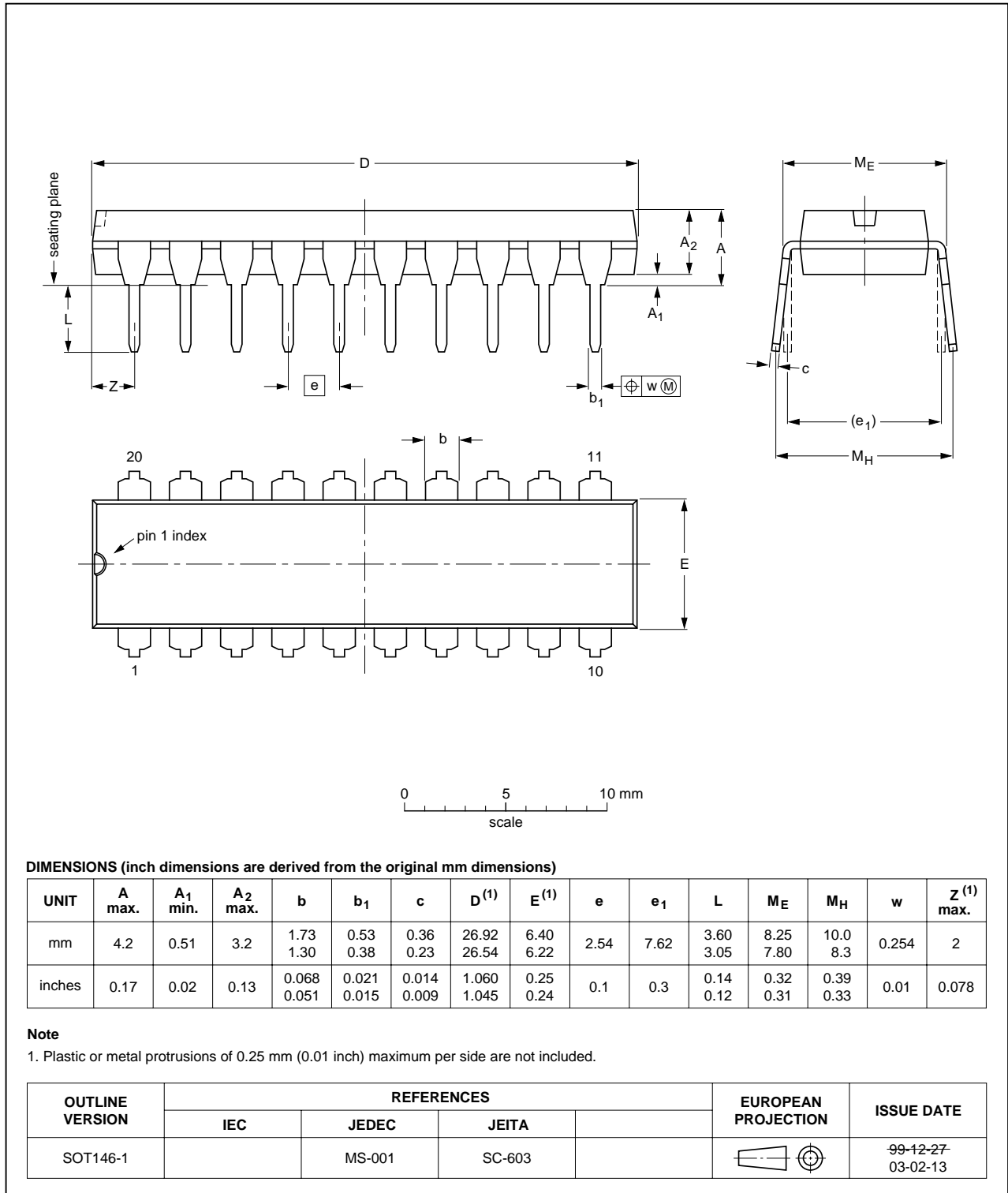

Fig 8. Package outline SOT146-1 (DIP20)

SO20: plastic small outline package; 20 leads; body width 7.5 mm

SOT163-1

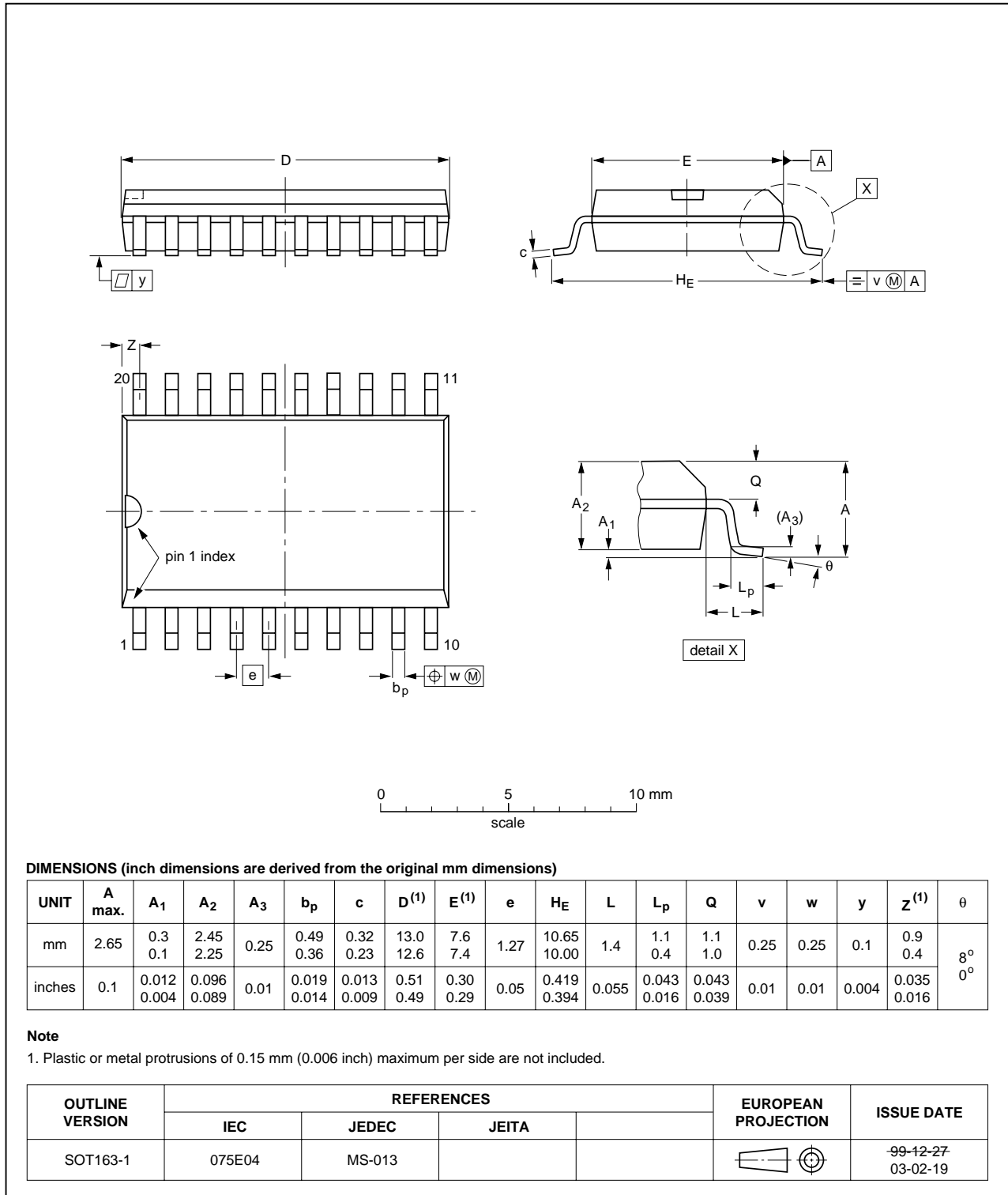

Fig 9. Package outline SOT163-1 (SO20)

TSSOP20: plastic thin shrink small outline package; 20 leads; body width 4.4 mm

SOT360-1

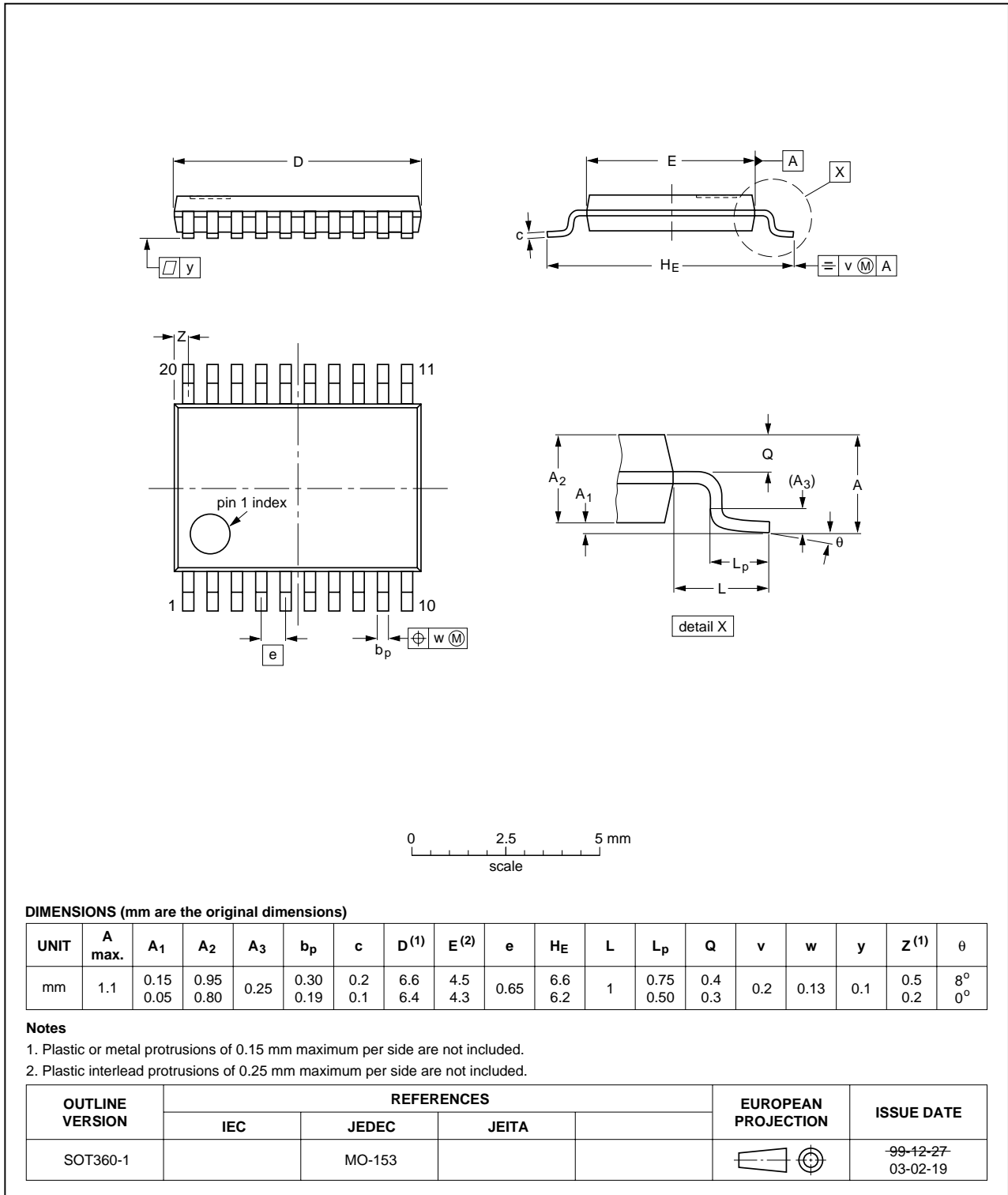

Fig 10. Package outline SOT360-1 (TSSOP20)

14. Revision history

Table 10: Revision history

Document ID	Release date	Data sheet status	Change notice	Doc. number	Supersedes
74ABT2240_4	20050117	Product data sheet	-	9397 750 14414	74ABT2240_3
Modifications:					
<ul style="list-style-type: none"> The format of this data sheet has been redesigned to comply with the new presentation and information standard of Philips Semiconductors. Section 2 "Features": modified 'JEDEC Std. 17' into 'JESD78'. Table 8 "Dynamic characteristics": changed min value of t_{pZL} from 4.2 ns into 3.5 ns for both conditions $V_{CC} = 5.0$ V at $T_{amb} = 25$ °C and $V_{CC} = 5.0$ V \pm 0.5 V at $T_{amb} = -40$ °C to +85 °C. 					
74ABT2240_3	20030425	Product specification	ECN 853-1626 29854	9397 750 11431	74ABT2240_2
74ABT2240_2	19980116	Product specification	ECN 853-1626 18865	9397 750 03463	74ABT2240_1
74ABT2240_1	19961008	Product specification	-	-	-

15. Data sheet status

Level	Data sheet status ^[1]	Product status ^[2] ^[3]	Definition
I	Objective data	Development	This data sheet contains data from the objective specification for product development. Philips Semiconductors reserves the right to change the specification in any manner without notice.
II	Preliminary data	Qualification	This data sheet contains data from the preliminary specification. Supplementary data will be published at a later date. Philips Semiconductors reserves the right to change the specification without notice, in order to improve the design and supply the best possible product.
III	Product data	Production	This data sheet contains data from the product specification. Philips Semiconductors reserves the right to make changes at any time in order to improve the design, manufacturing and supply. Relevant changes will be communicated via a Customer Product/Process Change Notification (CPCN).

[1] Please consult the most recently issued data sheet before initiating or completing a design.

[2] The product status of the device(s) described in this data sheet may have changed since this data sheet was published. The latest information is available on the Internet at URL <http://www.semiconductors.philips.com>.

[3] For data sheets describing multiple type numbers, the highest-level product status determines the data sheet status.

16. Definitions

Short-form specification — The data in a short-form specification is extracted from a full data sheet with the same type number and title. For detailed information see the relevant data sheet or data handbook.

Limiting values definition — Limiting values given are in accordance with the Absolute Maximum Rating System (IEC 60134). Stress above one or more of the limiting values may cause permanent damage to the device. These are stress ratings only and operation of the device at these or at any other conditions above those given in the Characteristics sections of the specification is not implied. Exposure to limiting values for extended periods may affect device reliability.

Application information — Applications that are described herein for any of these products are for illustrative purposes only. Philips Semiconductors make no representation or warranty that such applications will be suitable for the specified use without further testing or modification.

17. Disclaimers

Life support — These products are not designed for use in life support appliances, devices, or systems where malfunction of these products can reasonably be expected to result in personal injury. Philips Semiconductors customers using or selling these products for use in such applications do so at their own risk and agree to fully indemnify Philips Semiconductors for any damages resulting from such application.

Right to make changes — Philips Semiconductors reserves the right to make changes in the products - including circuits, standard cells, and/or software - described or contained herein in order to improve design and/or performance. When the product is in full production (status 'Production'), relevant changes will be communicated via a Customer Product/Process Change Notification (CPCN). Philips Semiconductors assumes no responsibility or liability for the use of any of these products, conveys no license or title under any patent, copyright, or mask work right to these products, and makes no representations or warranties that these products are free from patent, copyright, or mask work right infringement, unless otherwise specified.

18. Contact information

For additional information, please visit: <http://www.semiconductors.philips.com>

For sales office addresses, send an email to: sales.addresses@www.semiconductors.philips.com

19. Contents

1	General description	1
2	Features	1
3	Quick reference data	2
4	Ordering information	2
5	Functional diagram	3
6	Pinning information	4
6.1	Pinning	4
6.2	Pin description	4
7	Functional description	5
7.1	Function table	5
8	Limiting values	6
9	Recommended operating conditions	6
10	Static characteristics	7
11	Dynamic characteristics	9
12	Waveforms	9
13	Package outline	11
14	Revision history	14
15	Data sheet status	15
16	Definitions	15
17	Disclaimers	15
18	Contact information	15



© Koninklijke Philips Electronics N.V. 2005

All rights are reserved. Reproduction in whole or in part is prohibited without the prior written consent of the copyright owner. The information presented in this document does not form part of any quotation or contract, is believed to be accurate and reliable and may be changed without notice. No liability will be accepted by the publisher for any consequence of its use. Publication thereof does not convey nor imply any license under patent- or other industrial or intellectual property rights.

Date of release: 17 January 2005
Document number: 9397 750 14414

Published in The Netherlands

Looking for pricing, stock, or lifecycle information?

Click below to explore more details on WIN SOURCE:

- [View 74ABT2240D,118 on WIN SOURCE](#)
- [NXP / Nexperia Information](#)

Optimize Your Supply Chain with WIN SOURCE Solutions

- ✓ Global Sourcing Solution
- ✓ Obsolete Management
- ✓ Cost Control Management
- ✓ Shortage Management
- ✓ Alternative Solution
- ✓ Excess Inventory Management