



**THE DATASHEET OF
AT24C64BN-10SU-1.8**



**I²C-Compatible (2-Wire) Serial EEPROM
64K (8192 x 8)**

DATASHEET

Features

- Low-voltage and Standard-voltage Operation
 - 2.7V ($V_{CC} = 2.7V$ to 5.5V)
 - 1.8V ($V_{CC} = 1.8V$ to 5.5V)
- Low-power Devices ($I_{SB} = 6\mu A$ at 5.5V) Available
- Internally Organized 8192 x 8
- 2-Wire Serial Interface
- Schmitt Trigger, Filtered Inputs for Noise Suppression
- Bi-directional Data Transfer Protocol
- 400kHz Clock Rate
- Write Protect Pin for Hardware Data Protection
- 32-byte Page Write Mode (Partial Page Writes Allowed)
- Self-Timed Write Cycle (5ms max)
- High Reliability
 - Endurance: 1,000,000 Write Cycles
 - Data Retention: 100 Years
- Lead-free/Halogen-free Devices Available
- 8-lead JEDEC SOIC and TSSOP Packages

Description

The Atmel® AT24C64B provides 65,536 bits of Serial Electrically Erasable and Programmable Read-Only Memory (EEPROM) organized as 8,192 words of 8 bits each. The device's cascadable feature allows up to eight devices to share a common 2-Wire bus. The device is optimized for use in many industrial and commercial applications where low-power and low-voltage operation are essential. The AT24C64B is available in space saving 8-lead JEDEC SOIC and 8-lead TSSOP packages and is accessed via a 2-Wire serial interface. In addition, the entire family is available in 2.7V (2.7 to 5.5V) and 1.8V (1.8 to 5.5V) versions.

1. Pin Configurations

Table 1-1. Pin Configurations

Pin Name	Function
A ₀ – A ₂	Address Inputs
GND	Ground
SCL	Serial Clock Input
SDA	Serial Data
WP	Write Protect
V _{CC}	Power Supply

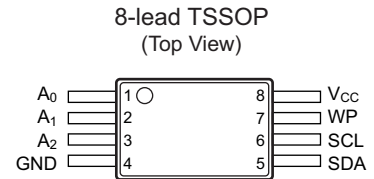
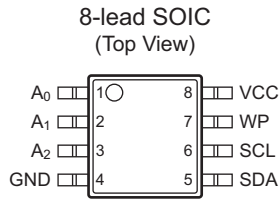

2. Absolute Maximum Ratings*

Operating Temperature-55 to +125°C
Storage Temperature-65 to +150°C
Voltage on Any Pin with Respect to Ground -1V to +7V
Maximum Operating Voltage 6.25V
DC Output Current 5mA

*Notice: Stresses beyond those listed under “Absolute Maximum Ratings” may cause permanent damage to the device. This is a stress rating only and functional operation of the device at these or any other conditions beyond those indicated in the operational sections of this specification is not implied. Exposure to absolute maximum rating conditions for extended periods may affect device reliability.

3. Block Diagram

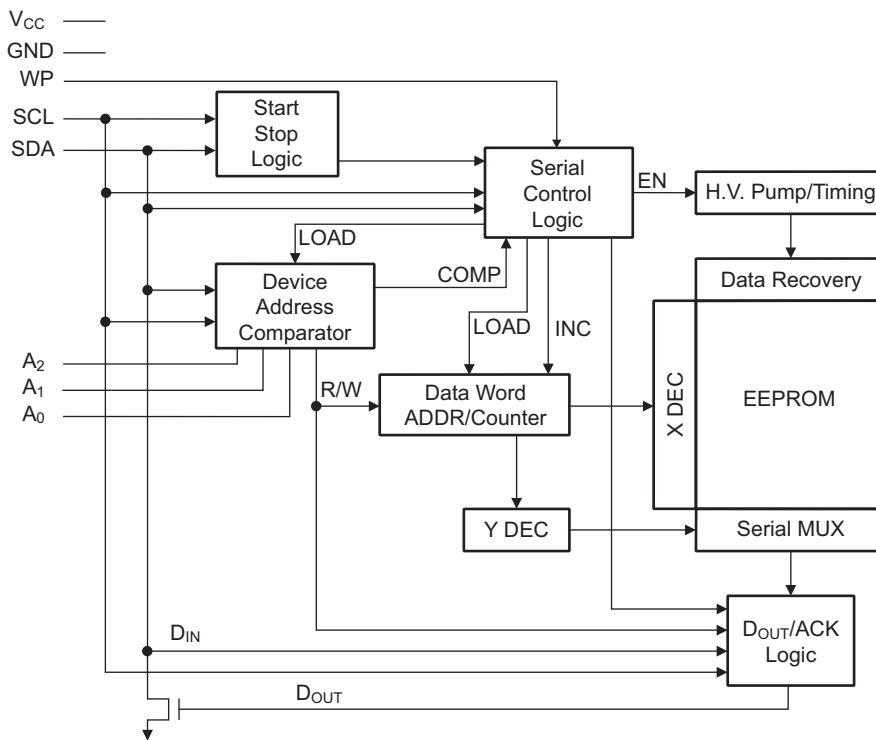

4. Pin Description

Serial Clock (SCL): The SCL input is used to positive edge clock data into each EEPROM device and negative edge clock data out of each device.

Serial Data (SDA): The SDA pin is bidirectional for serial data transfer. This pin is open-drain driven and may be wire-ORed with any number of other open-drain or open collector devices.

Device Addresses (A₂, A₁, A₀): The A₂, A₁, and A₀ pins are Device Address inputs which are hardwired or left not connected for hardware compatibility with other AT24Cxxx devices. When the pins are hardwired, as many as eight 64Kb devices may be addressed on a single bus system (see Section 7., “Device Addressing”). If the pins are left floating, the A₂, A₁, and A₀ pins will be internally pulled down to GND if the capacitive coupling to the circuit board V_{CC} plane is <3pF. If coupling is >3pF, Atmel recommends connecting the address pins to GND.

Write Protect (WP): The Write Protect input, when connected to GND, allows normal Write operations. When WP is connected high to V_{CC}, all Write operations to the upper quadrant (16Kb) of memory are inhibited. If the pin is left floating, the WP pin will be internally pulled down to GND if the capacitive coupling to the circuit board V_{CC} plane is <3pF. If coupling is >3pF, Atmel recommends connecting the pin to GND.

5. Memory Organization

AT24C64B, 64K Serial EEPROM: The 64K is internally organized as 256 pages of 32 bytes each. Random word addressing requires a 13 bit data word address.

5.1 Pin Capacitance ⁽¹⁾

Applicable over recommended operating range from $T_A = 25^\circ\text{C}$, $f = 1\text{MHz}$, $V_{CC} = +5.0\text{V}$.

Symbol	Test Condition	Max	Units	Conditions
$C_{I/O}$	Input/Output Capacitance (SDA)	8	pF	$V_{I/O} = 0\text{V}$
C_{IN}	Input Capacitance ($A_0, A_1, A_2, \text{SCL}$)	6	pF	$V_{IN} = 0\text{V}$

Note: 1. This parameter is characterized and is not 100% tested.

5.2 DC Characteristics

Applicable over recommended operating range from: $T_{AI} = -40$ to $+85^\circ\text{C}$, $V_{CC} = +1.8\text{V}$ to $+5.5\text{V}$ (unless otherwise noted).

Symbol	Parameter	Test Condition		Min	Typ	Max	Units
V_{CC1}	Supply Voltage			1.8		5.5	V
V_{CC2}	Supply Voltage			2.7		5.5	V
V_{CC3}	Supply Voltage			4.5		5.5	V
I_{CC1}	Supply Current	$V_{CC} = 5.0\text{V}$	Read at 400kHz		0.4	1.0	mA
I_{CC2}	Supply Current	$V_{CC} = 5.0\text{V}$	Write at 400kHz		2.0	3.0	mA
I_{SB1}	Standby Current (1.8V Option)	$V_{CC} = 1.8\text{V}$	$V_{IN} = V_{CC}$ or V_{SS}			1.0	μA
I_{SB2}	Standby Current (2.7V Option)	$V_{CC} = 2.7\text{V}$	$V_{IN} = V_{CC}$ or V_{SS}			2.0	μA
I_{SB3}	Standby Current (5.0V Option)	$V_{CC} = 4.5 - 5.5\text{V}$	$V_{IN} = V_{CC}$ or V_{SS}			6.0	μA
I_{LI}	Input Leakage Current	$V_{IN} = V_{CC}$ or V_{SS}			0.10	3.0	μA
I_{LO}	Output Leakage Current	$V_{OUT} = V_{CC}$ or V_{SS}			0.05	3.0	μA
V_{IL}	Input Low Level ⁽¹⁾			-0.6		$V_{CC} \times 0.3$	V
V_{IH}	Input High Level ⁽¹⁾			$V_{CC} \times 0.7$		$V_{CC} + 0.5$	V
V_{OL2}	Output Low Level	$V_{CC} = 3.0\text{V}$	$I_{OL} = 2.10\text{mA}$			0.4	V
V_{OL1}	Output Low Level	$V_{CC} = 1.8\text{V}$	$I_{OL} = 0.15\text{mA}$			0.2	V

Note: 1. V_{IL} min and V_{IH} max are reference only and are not tested.

5.3 AC Characteristics

Applicable over recommended operating range from $T_{AI} = -40^{\circ}\text{C}$ to $+85^{\circ}\text{C}$, $V_{CC} = +1.8\text{V}$ to $+5.5\text{V}$, $CL = 1$ TTL Gate and 100pF (unless otherwise noted). Test conditions are listed in [Note 2](#).

Symbol	Parameter	1.8V to 3.6V		5V		Units
		Min	Max	Min	Max	
f_{SCL}	Clock Frequency, SCL		400		400	kHz
t_{LOW}	Clock Pulse Width Low	1.3		1.2		μs
t_{HIGH}	Clock Pulse Width High	0.6		0.6		μs
t_I	Noise Suppression Time ⁽¹⁾		100		50	ns
t_{AA}	Clock Low to Data Out Valid	0.2	0.9	0.1	0.9	μs
t_{BUF}	Time the bus must be free before a new transmission can start ⁽¹⁾	1.3		1.2		μs
$t_{HD.STA}$	Start Hold Time	0.6		0.6		μs
$t_{SU.STA}$	Start Set-up Time	0.6		0.6		μs
$t_{HD.DAT}$	Data In Hold Time	0		0		μs
$t_{SU.DAT}$	Data In Set-up Time	100		100		ns
t_R	Inputs Rise Time ⁽¹⁾		0.3		0.3	μs
t_F	Inputs Fall Time ⁽¹⁾		300		300	ns
$t_{SU.STO}$	Stop Set-up Time	0.6		0.6		μs
t_{DH}	Data Out Hold Time	200		50		ns
t_{WR}	Write Cycle Time		5		5	ms
Endurance ⁽¹⁾	25°C, Page Mode, 5.0V	1,000,000				Write Cycles

Notes: 1. This parameter is characterized and is not 100% tested ($T_A = 25^{\circ}\text{C}$).

2. AC measurement conditions:

- R_L (connects to V_{CC}): $1.3\text{k}\Omega$ (2.5V, 5.5V), $10\text{k}\Omega$ (1.7V)
- Input pulse voltages: $0.3V_{CC}$ to $0.7V_{CC}$
- Input rise and fall times: $\leq 50\text{ns}$
- Input and output timing reference voltages: $0.5 \times V_{CC}$

6. Device Operation

Clock and Data Transitions: The SDA pin is normally pulled high with an external device. Data on the SDA pin may change only during SCL low time periods. Data changes during SCL high periods will indicate a Start or Stop condition as defined below.

Figure 6-1. Data Validity

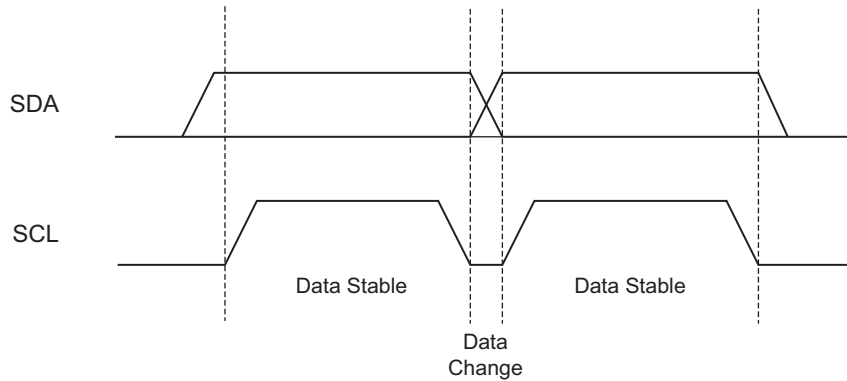

Start Condition: A high-to-low transition of SDA with SCL high is a Start condition which must precede any other command.

Stop Condition: A low-to-high transition of SDA with SCL high is a Stop condition. After a read sequence, the Stop command will place the EEPROM in a standby power mode.

Figure 6-2. Start and Stop Definition

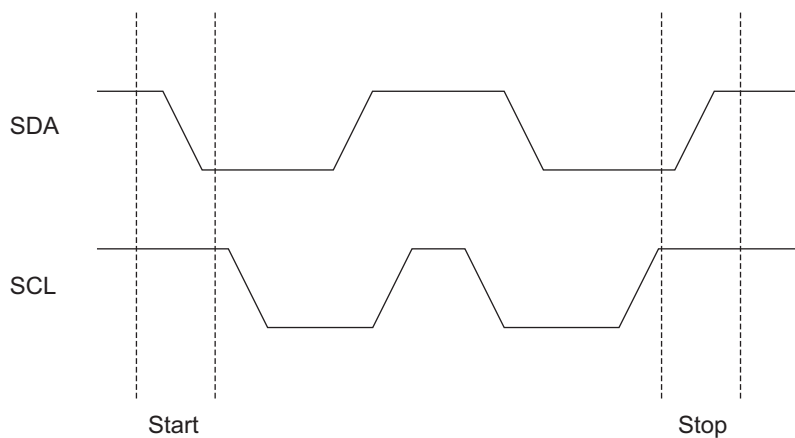

Acknowledge: All addresses and data words are serially transmitted to and from the EEPROM in 8-bit words. The EEPROM sends a zero during the ninth clock cycle to acknowledge that it has received each word.

Figure 6-3. Output Acknowledge

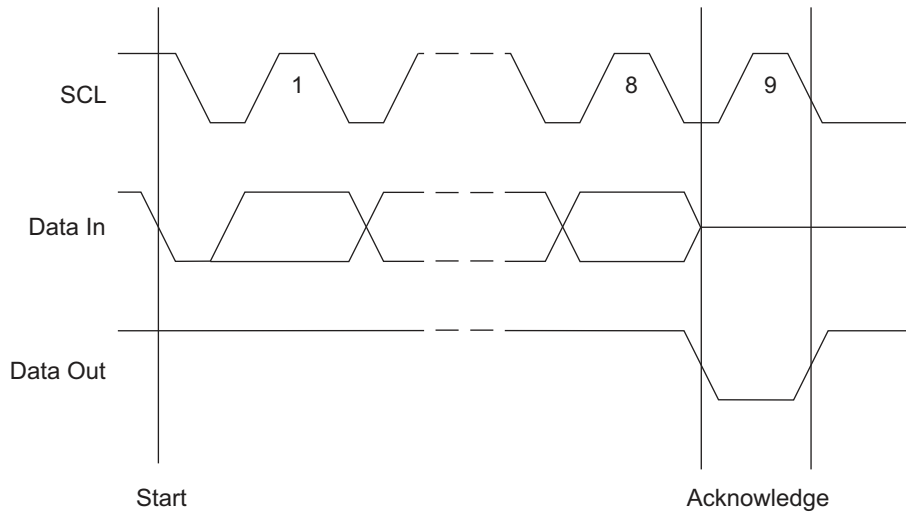

Standby Mode: The AT24C64B features a low-power standby mode which is enabled:

- Upon power-up,
- After the receipt of the Stop bit, and
- Completion of any internal operations.

Memory Reset: After an interruption in protocol, power loss or system reset, any 2-Wire part can be reset by following these steps:

1. Clock up to nine cycles,
2. Look for SDA high in each cycle while SCL is high,
3. Create a Start condition as SDA is high.

The device is ready for the next communication after the above steps have been completed.

Figure 6-4. Software Reset

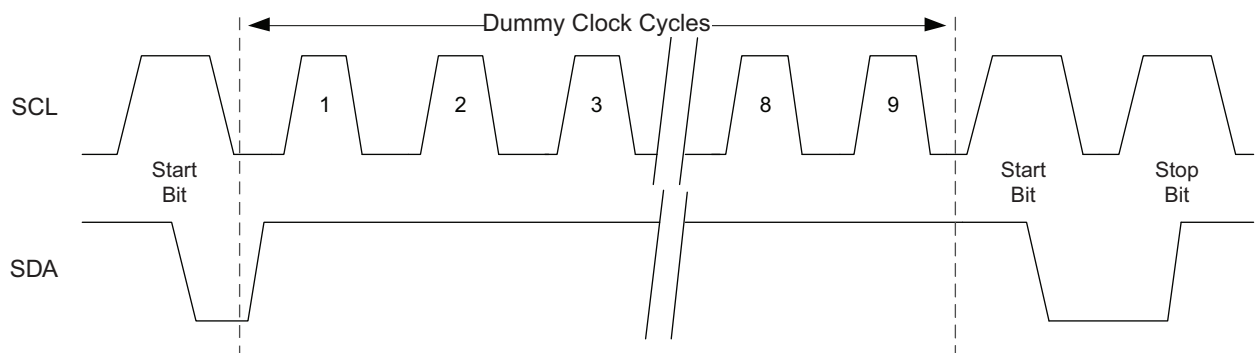

Figure 6-5. Bus Timing — SCL: Serial Clock, SDA: Serial Data I/O

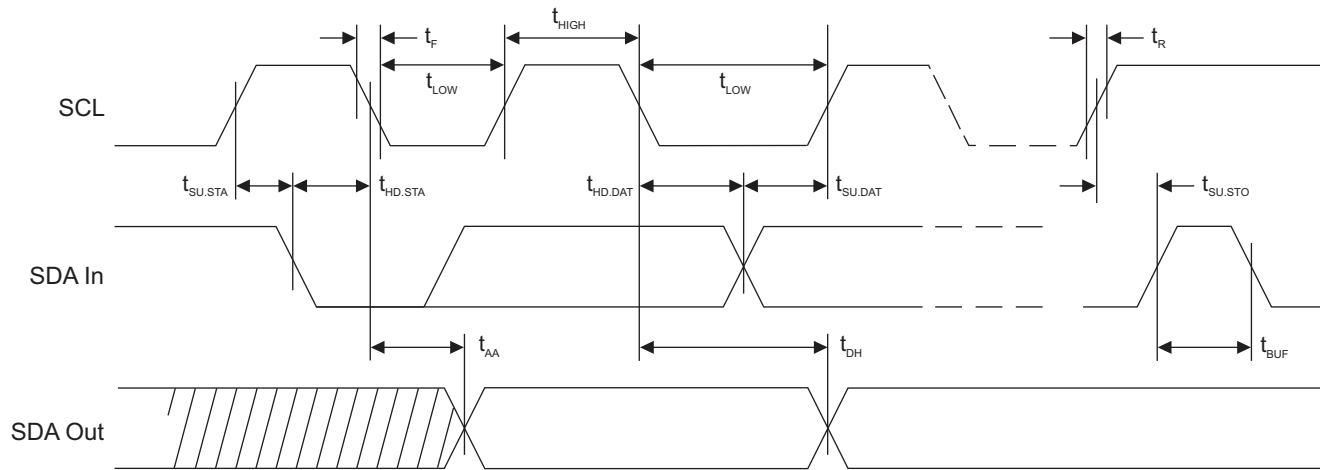
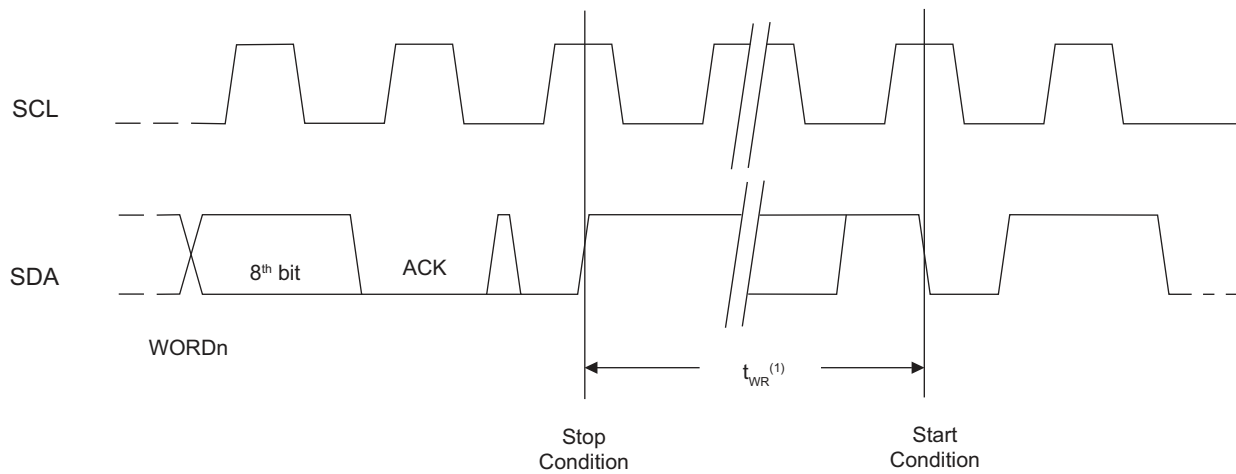

Figure 6-6. Write Cycle Timing — SCL: Serial Clock, SDA: Serial Data I/O



Note: 1. The write cycle time t_{WR} is the time from a valid Stop condition of a Write Sequence to the end of the internal clear/write cycle.

7. Device Addressing

The 64Kb EEPROM requires an 8-bit device address word following a Start condition to enable the device for a Read or Write operation. The device address word consists of a mandatory one, zero sequence for the first four most significant bits as shown below. This is common to all 2-Wire EEPROM devices.

Figure 7-1. Device Address

1	0	1	0	A2	A1	A0	R/W
MSB				LSB			

The 64Kb uses the three Device Address bits A2, A1, and A0 to allow as many as eight devices on the same bus. These bits must compare to their corresponding hardwired input pins. The A₂, A₁, and A₀ pins use an internal proprietary circuit that biases them to a Logic Low condition if the pins are allowed to float.

The eighth bit of the Device Address is the Read/Write operation select bit. A Read operation is initiated if this bit is high, and a Write operation is initiated if this bit is low.

Upon a compare of the Device Address, the EEPROM will output a zero. If a compare is not made, the device will return to standby state.

Noise Protection: Special internal circuitry placed on the SDA and SCL pins prevent small noise spikes from activating the device. A low-V_{CC} detector resets the device to prevent data corruption in a noisy environment.

Data Security: The AT24C64B has a hardware data protection scheme which allows the user to write protect the upper quadrant (16Kb) of memory when the WP pin is at V_{CC}.

8. Write Operations

Byte Write: A Write operation requires two 8-bit data word addresses following the device address word and acknowledgment. Upon receipt of this address, the EEPROM will again respond with a zero and then clock in the first 8-bit data word. Following receipt of the 8-bit data word, the EEPROM will output a zero and the addressing device, i.e. microcontroller, must terminate the write sequence with a Stop condition. At this time, the EEPROM enters an internally-timed write cycle, t_{WR} , to the nonvolatile memory. All inputs are disabled during this write cycle and the EEPROM will not respond until the write is complete.

Figure 8-1. Byte Write

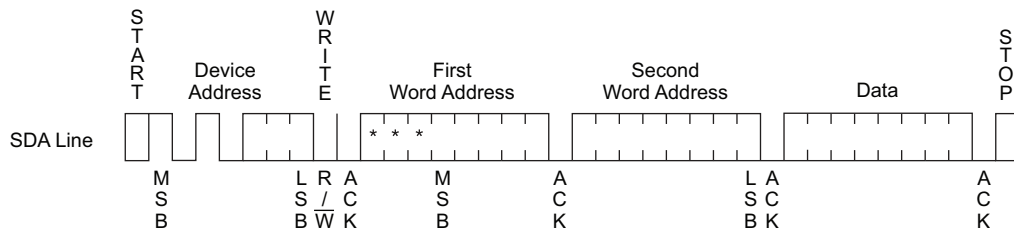

Note: * = Don't Care bits

Page Write: The 64K EEPROM is capable of 32-byte Page Writes.

A Page Write is initiated the same way as a Byte Write, but the microcontroller does not send a Stop condition after the first data word is clocked in. Instead, after the EEPROM acknowledges receipt of the first data word, the microcontroller can transmit up to 31 more data words. The EEPROM will respond with a zero after each data word received. The microcontroller must terminate the Page Write sequence with a Stop condition.

Figure 8-2. Page Write

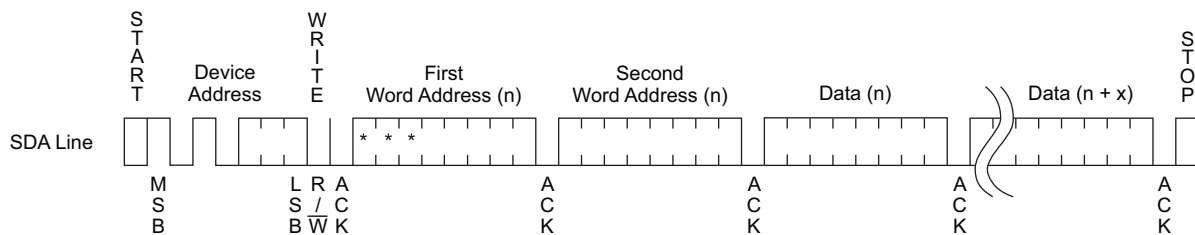

Note: * = Don't Care bits

The data word address' lower five bits are internally incremented following the receipt of each data word. The higher data word address bits are not incremented, retaining the memory page row location. When the word address, internally generated, reaches the page boundary, the following byte is placed at the beginning of the same page. If more than 32 data words are transmitted to the EEPROM, the data word address will roll-over and the previous data will be overwritten.

Acknowledge Polling: Once the internally-timed write cycle has started and the EEPROM inputs are disabled, Acknowledge Polling can be initiated. This involves sending a Start condition followed by the device address word. The Read/Write bit is representative of the operation desired. Only if the internal write cycle has completed will the EEPROM respond with a zero, allowing the Read or Write Sequence to continue.

9. Read Operations

Read operations are initiated the same way as Write operations with the exception the Read/Write Select bit in the device address word is set to one. There are three read operations:

- Current Address Read
- Random Address Read
- Sequential Read

Current Address Read: The internal data word address counter maintains the last address accessed during the last Read or Write operation, incremented by one. This address stays valid between operations as long as the device power is maintained. The address roll-over during Read is from the last byte of the last memory page to the first byte of the first page. The address roll-over during Write is from the last byte of the current page to the first byte of the same page.

Once the Device Address with the Read/Write Select bit set to one is clocked in and acknowledged by the EEPROM, the current address data word is serially clocked out. The microcontroller does not respond with an input zero but does generate a following Stop condition.

Figure 9-1. Current Address Read

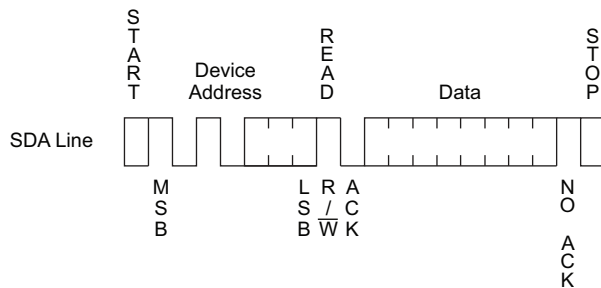

Random Read: A Random Read requires a dummy Byte Write sequence to load in the data word address. Once the device address word and data word address are clocked in and acknowledged by the EEPROM, the microcontroller must generate another Start condition. The microcontroller now initiates a Current Address Read by sending a Device Address with the Read/Write Select bit high. The EEPROM acknowledges the Device Address and serially clocks out the data word. The microcontroller does not respond with a zero but does generate a following Stop condition.

Figure 9-2. Random Read

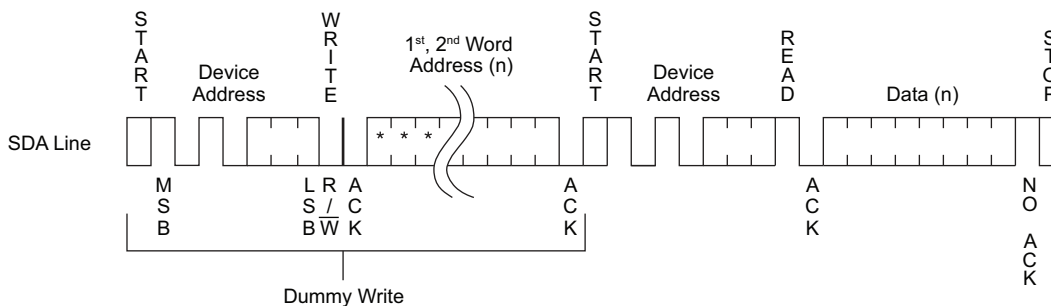

Note: 1. * = Don't Care bits

Sequential Read: Sequential Reads are initiated by either a Current Address Read or a Random Address Read. After the microcontroller receives a data word, it responds with an acknowledge. As long as the EEPROM receives an acknowledge, it will continue to increment the data word address and serially clock out sequential data words. When the memory address limit is reached, the data word address will roll-over and the Sequential Read will continue. The Sequential Read operation is terminated when the microcontroller does not respond with a zero but does generate a following Stop condition.

Figure 9-3. Sequential Read

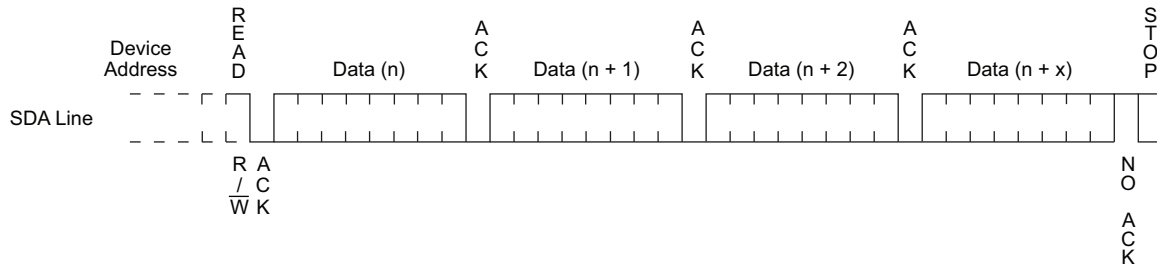

10. Ordering Code Detail

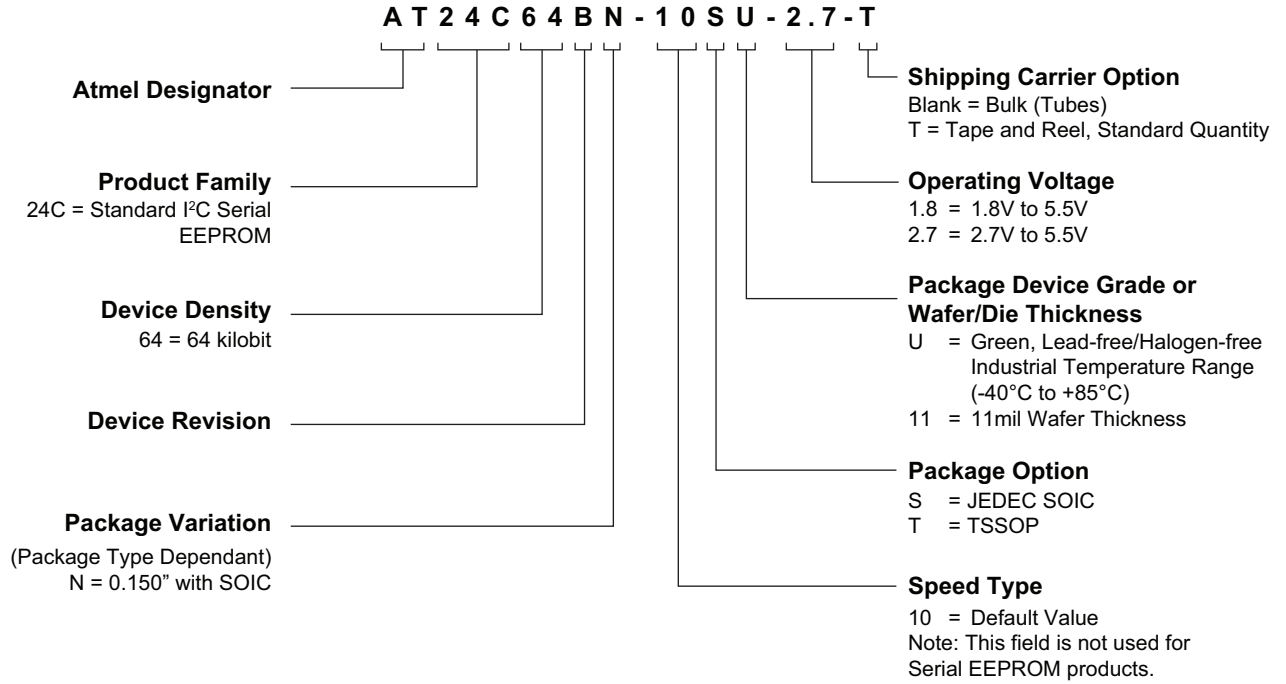

11. Part Markings

AT24C64B: Package Marking Information

8-lead SOIC⁽³⁾

8-lead TSSOP⁽⁴⁾

Note 1: ● designates pin 1
 Note 2: Package drawings are not to scale
 Note 3: Back side marking will include Assembly Location and Lot Number
 Note 4: Back side marking will include Date Code, Assembly Location and Lot Number

Date Codes			Voltages	
Y = Year	M = Month	WW = Work Week of Assembly	% = Minimum Voltage	
9: 2009 3: 2013	A: January	02: Week 2	18 or 1: 1.8V min	
0: 2010 4: 2014	B: February	04: Week 4	27 or 3: 2.7V min	
1: 2011 5: 2015		
2: 2012 6: 2016	L: December	52: Week 52		
Country of Assembly		Lot Number		Grade/Lead Finish Material
@ = Country of Assembly		AAA...A = Atmel Wafer Lot Number		U: Industrial/Matte Tin/SnAguCu
Trace Code			Atmel Truncation	
XX = Trace Code (Atmel Lot Numbers Correspond to Code) Example: AA, AB.... YZ, ZZ			AT: Atmel ATM: Atmel ATML: Atmel	

1/31/14

Package Mark Contact: DL-CSO-Assy_eng@atmel.com	TITLE 24C64BBSM , AT24C64B Package Marking Information	DRAWING NO. 24C64BBSM	REV. A
--	---	---------------------------------	------------------

12. Ordering Information

Atmel Ordering Code	Lead Finish	Package	Voltage	Delivery Information		Operation Range
				Form	Quantity	
AT24C64BN-10SU-2.7	Matte Tin ⁽²⁾ Lead-free Halogen-free	8S1	2.7V to 5.5V ⁽¹⁾	Bulk (Tubes)	100 per Tube	Industrial Temperature (-40°C to 85°C)
AT24C64BN-10SU-2.7-T				Tape and Reel	4,000 per Reel	
AT24C64BN-10SU-1.8			1.8V to 5.5V	Bulk (Tubes)	100 per Tube	
AT24C64BN-10SU-1.8-T				Tape and Reel	4,000 per Reel	
AT24C64B-10TU-2.7		8X	2.7V to 5.5V ⁽¹⁾	Bulk (Tubes)	100 per Tube	
AT24C64B-10TU-2.7-T				Tape and Reel	5,000 per Reel	
AT24C64B-10TU-1.8			1.8V to 5.5V	Bulk (Tubes)	100 per Tube	
AT24C64B-10TU-1.8-T				Tape and Reel	5,000 per Reel	

- Notes: 1. For 2.7V devices used in the 4.5V to 5.5V range, see [Section 5.2, “DC Characteristics”](#) and [Section 5.3, “AC Characteristics”](#).
 2. U = Green Package and RoHS compliant.

Package Type	
8S1	8-lead 0.150” wide body, Plastic Gull Wing Small Outline (JEDEC SOIC)
8X	8-lead 4.4mm body, Plastic Thin Shrink Small Outline Package (TSSOP)

13. Packaging Information

13.1 8S1 — 8-lead JEDEC SOIC

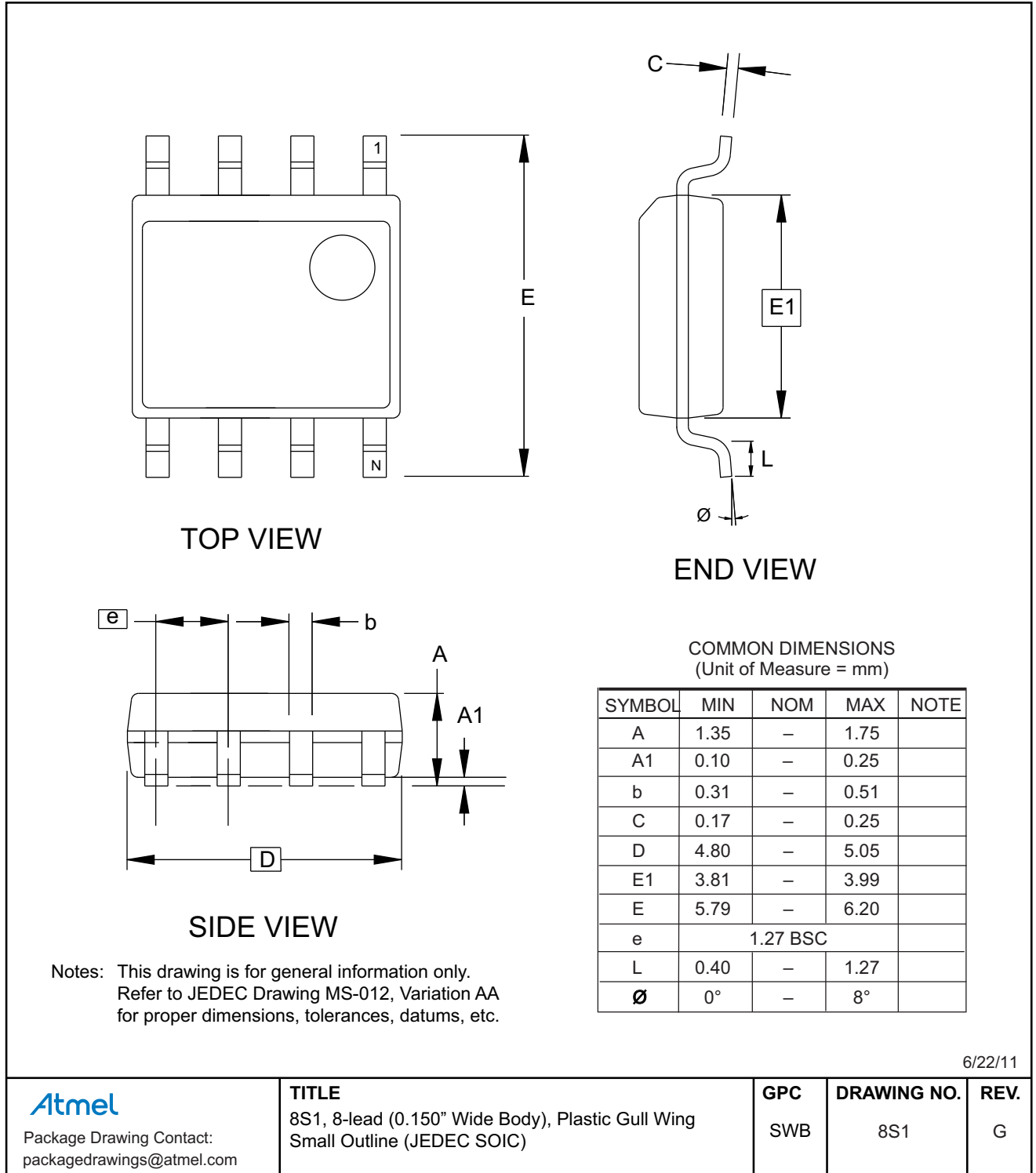

13.2 8X — 8-lead TSSOP

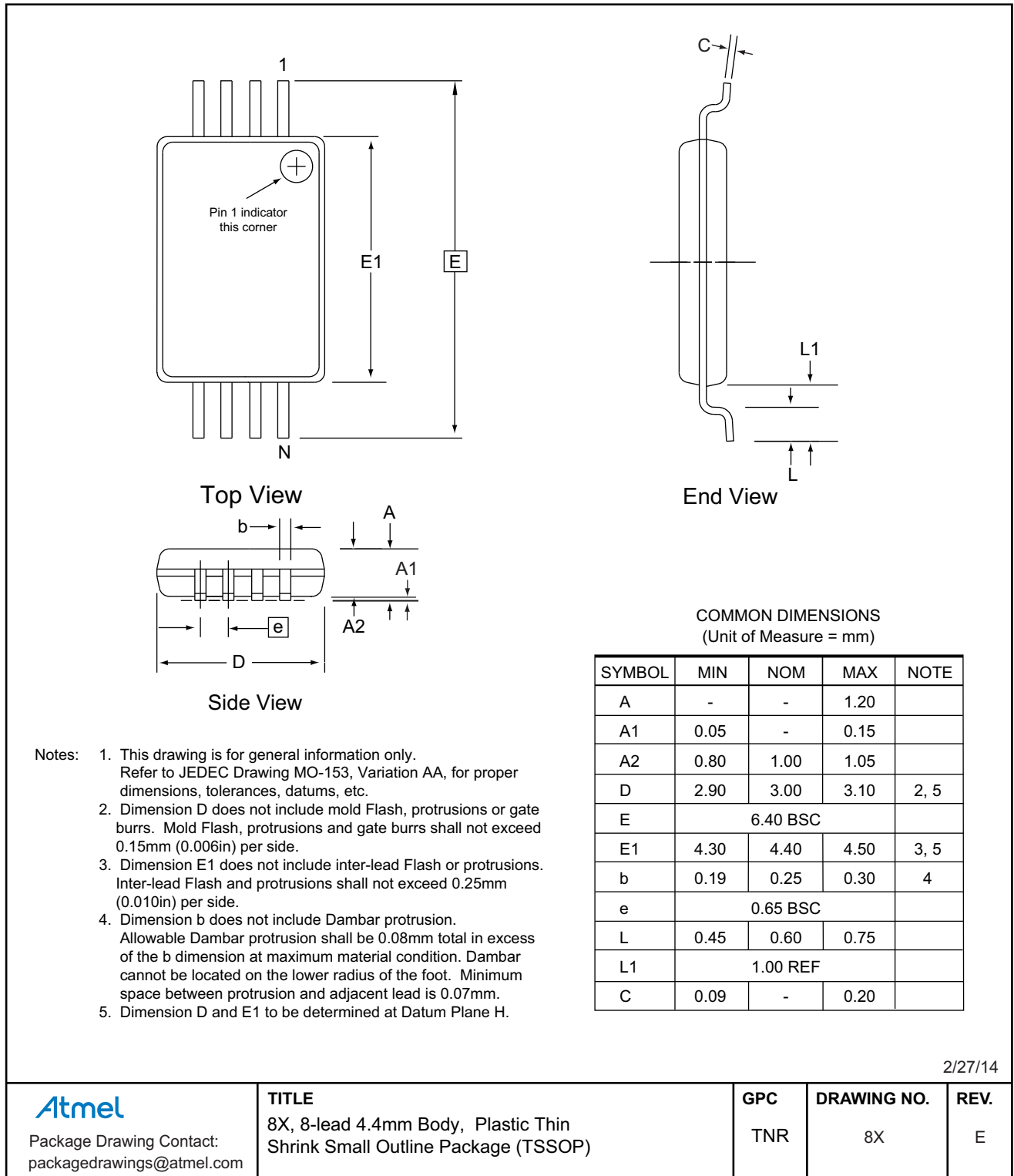

14. Revision History

Doc. Rev.	Date	Comments
3350G	01/2017	Added Bulk (Tube) Shipping Carrier Option Changed Standard Quantity Tape and Reel Option to "T" Updated Ordering Information Table Removed AT24C64B-W1.8-11 Part Number
3350F	05/2014	Add ordering code detail and part markings. Update the 8X package drawing, template, logos, and disclaimer page. (No change in functional specification.)
3350E	09/2007	Update template; implemented revision history.

Atmel®, Atmel logo and combinations thereof, Enabling Unlimited Possibilities, and others are registered trademarks or trademarks of Atmel Corporation in U.S. and other countries. Other terms and product names may be trademarks of others.

DISCLAIMER: The information in this document is provided in connection with Atmel products. No license, express or implied, by estoppel or otherwise, to any intellectual property right is granted by this document or in connection with the sale of Atmel products. EXCEPT AS SET FORTH IN THE ATMEL TERMS AND CONDITIONS OF SALES LOCATED ON THE ATMEL WEBSITE, ATMEL ASSUMES NO LIABILITY WHATSOEVER AND DISCLAIMS ANY EXPRESS, IMPLIED OR STATUTORY WARRANTY RELATING TO ITS PRODUCTS INCLUDING, BUT NOT LIMITED TO, THE IMPLIED WARRANTY OF MERCHANTABILITY, FITNESS FOR A PARTICULAR PURPOSE, OR NON-INFRINGEMENT. IN NO EVENT SHALL ATMEL BE LIABLE FOR ANY DIRECT, INDIRECT, CONSEQUENTIAL, PUNITIVE, SPECIAL OR INCIDENTAL DAMAGES (INCLUDING, WITHOUT LIMITATION, DAMAGES FOR LOSS AND PROFITS, BUSINESS INTERRUPTION, OR LOSS OF INFORMATION) ARISING OUT OF THE USE OR INABILITY TO USE THIS DOCUMENT, EVEN IF ATMEL HAS BEEN ADVISED OF THE POSSIBILITY OF SUCH DAMAGES. Atmel makes no representations or warranties with respect to the accuracy or completeness of the contents of this document and reserves the right to make changes to specifications and products descriptions at any time without notice. Atmel does not make any commitment to update the information contained herein. Unless specifically provided otherwise, Atmel products are not suitable for, and shall not be used in, automotive applications. Atmel products are not intended, authorized, or warranted for use as components in applications intended to support or sustain life.

SAFETY-CRITICAL, MILITARY, AND AUTOMOTIVE APPLICATIONS DISCLAIMER: Atmel products are not designed for and will not be used in connection with any applications where the failure of such products would reasonably be expected to result in significant personal injury or death ("Safety-Critical Applications") without an Atmel officer's specific written consent. Safety-Critical Applications include, without limitation, life support devices and systems, equipment or systems for the operation of nuclear facilities and weapons systems. Atmel products are not designed nor intended for use in military or aerospace applications or environments unless specifically designated by Atmel as military-grade. Atmel products are not designed nor intended for use in automotive applications unless specifically designated by Atmel as automotive-grade.

Looking for pricing, stock, or lifecycle information?

Click below to explore more details on WIN SOURCE:

- ⊖ [View AT24C64BN-10SU-1.8 on WIN SOURCE](#)
- ⊖ [Microchip Technology Information](#)

Optimize Your Supply Chain with WIN SOURCE Solutions

- ✓ Global Sourcing Solution
- ✓ Obsolete Management
- ✓ Cost Control Management
- ✓ Shortage Management
- ✓ Alternative Solution
- ✓ Excess Inventory Management