

## 0.9 $\mu$ A, High Precision Op Amps

### Features

- Rail-to-Rail Input and Output
- Low Offset Voltage:  $\pm 150 \mu\text{V}$  (maximum)
- Ultra Low Quiescent Current:  $0.9 \mu\text{A}$  (typical)
- Wide Power Supply Voltage: 1.8V to 5.5V
- Gain Bandwidth Product: 10 kHz (typical)
- Unity Gain Stable
- Chip Select ( $\overline{\text{CS}}$ ) capability: MCP6033
- Extended Temperature Range:
  - $-40^\circ\text{C}$  to  $+125^\circ\text{C}$
- No Phase Reversal

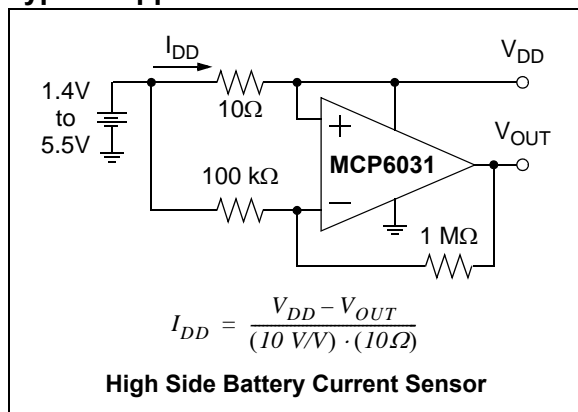
### Applications

- Toll Booth Tags
- Wearable Products
- Battery Current Monitoring
- Sensor Conditioning
- Battery Powered

### Design Aids

- SPICE Macro Models
- FilterLab<sup>®</sup> Software
- Mindi<sup>™</sup> Circuit Designer & Simulator
- MAPS (Microchip Advanced Part Selector)
- Analog Demonstration and Evaluation Boards
- Application Notes

### Typical Application



### Description

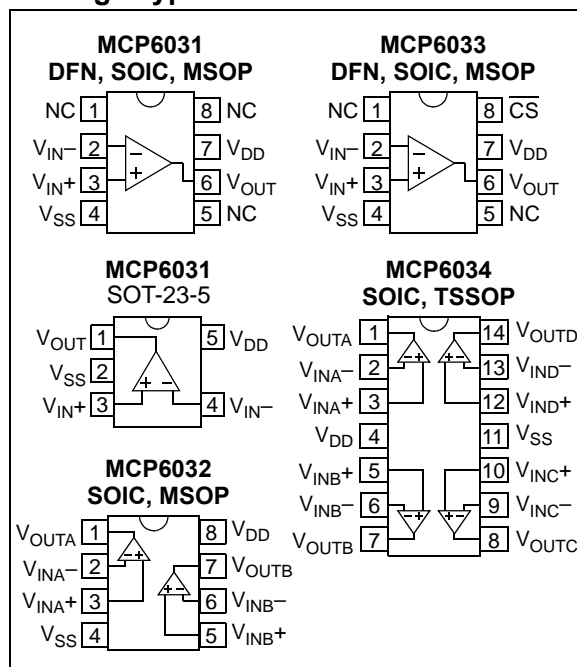
The Microchip Technology Inc. MCP6031/2/3/4 family of operational amplifiers (op amps) operate with a single supply voltage as low as 1.8V, while drawing ultra low quiescent current per amplifier ( $0.9 \mu\text{A}$ , typical). This family also has low input offset voltage ( $\pm 150 \mu\text{V}$ , maximum) and rail-to-rail input and output operation. This combination of features supports battery-powered and portable applications.

The MCP6031/2/3/4 family is unity gain stable and has a gain bandwidth product of 10 kHz (typical). These specs make these op amps appropriate for low frequency applications, such as battery current monitoring and sensor conditioning.

The MCP6031/2/3/4 family is offered in single (MCP6031), single with power saving Chip Select ( $\overline{\text{CS}}$ ) input (MCP6033), dual (MCP6032), and quad (MCP6034) configurations.

The MCP6031/2/3/4 family is designed with Microchip's advanced CMOS process. All devices are available in the extended temperature range, with a power supply range of 1.8V to 5.5V.

### Package Types



# MCP6031/2/3/4

## 1.0 ELECTRICAL CHARACTERISTICS

### Absolute Maximum Ratings †

$V_{DD} - V_{SS}$ .....	7.0V
Current at Input Pins .....	±2 mA
Analog Inputs ( $V_{IN+}$ , $V_{IN-}$ )†† .....	$V_{SS} - 1.0V$ to $V_{DD} + 1.0V$
All Other Inputs and Outputs .....	$V_{SS} - 0.3V$ to $V_{DD} + 0.3V$
Difference Input Voltage .....	$ V_{DD} - V_{SS} $
Output Short-Circuit Current .....	continuous
Current at Output and Supply Pins .....	±30 mA
Storage Temperature.....	-65°C to +150°C
Maximum Junction Temperature ( $T_J$ ) .....	+150°C
ESD protection on all pins (HBM; MM) .....	≥ 4 kV; 400V

† **Notice:** Stresses above those listed under “Absolute Maximum Ratings” may cause permanent damage to the device. This is a stress rating only and functional operation of the device at those or any other conditions above those indicated in the operational listings of this specification is not implied. Exposure to maximum rating conditions for extended periods may affect device reliability.

†† See 4.1.2 “Input Voltage And Current Limits”

### DC ELECTRICAL SPECIFICATIONS

**Electrical Characteristics:** Unless otherwise indicated,  $V_{DD} = +1.8V$  to  $+5.5V$ ,  $V_{SS} = GND$ ,  $T_A = +25^\circ C$ ,  $V_{CM} = V_{DD}/2$ ,  $V_{OUT} \approx V_{DD}/2$ ,  $V_L = V_{DD}/2$ ,  $R_L = 1 M\Omega$  to  $V_L$  and CS is tied low. (Refer to Figure 1-2 and Figure 1-3).

Parameters	Sym	Min	Typ	Max	Units	Conditions
<b>Input Offset</b>						
Input Offset Voltage	$V_{OS}$	-150	—	+150	$\mu V$	$V_{DD} = 3.0V$ , $V_{CM} = V_{DD}/3$
Input Offset Drift with Temperature	$\Delta V_{OS}/\Delta T_A$	—	±3.0	—	$\mu V/^\circ C$	$T_A = -40^\circ C$ to $+125^\circ C$ , $V_{DD} = 3.0V$ , $V_{CM} = V_{DD}/3$
Power Supply Rejection Ratio	PSRR	70	88	—	dB	$V_{CM} = V_{SS}$
<b>Input Bias Current and Impedance</b>						
Input Bias Current	$I_B$	—	±1.0	100	pA	$T_A = +85^\circ C$ $T_A = +125^\circ C$
	$I_B$	—	60	—	pA	
	$I_B$	—	2000	5000	pA	
Input Offset Current	$I_{OS}$	—	±1.0	—	pA	
Common Mode Input Impedance	$Z_{CM}$	—	$10^{13}    6$	—	$\Omega    pF$	
Differential Input Impedance	$Z_{DIFF}$	—	$10^{13}    6$	—	$\Omega    pF$	
<b>Common Mode</b>						
Common Mode Input Voltage Range	$V_{CMR}$	$V_{SS} - 0.3$	—	$V_{DD} + 0.3$	V	
Common Mode Rejection Ratio	CMRR	70	95	—	dB	$V_{CM} = -0.3V$ to $2.1V$ , $V_{DD} = 1.8V$
		72	93	—	dB	$V_{CM} = -0.3V$ to $5.8V$ , $V_{DD} = 5.5V$
		70	89	—	dB	$V_{CM} = 2.75V$ to $5.8V$ , $V_{DD} = 5.5V$
		72	93	—	dB	$V_{CM} = -0.3V$ to $2.75V$ , $V_{DD} = 5.5V$
<b>Open-Loop Gain</b>						
DC Open-Loop Gain (Large Signal)	$A_{OL}$	95	115	—	dB	$0.2V < V_{OUT} < (V_{DD} - 0.2V)$ $R_L = 50 k\Omega$ to $V_L$

## DC ELECTRICAL SPECIFICATIONS (CONTINUED)

**Electrical Characteristics:** Unless otherwise indicated,  $V_{DD} = +1.8V$  to  $+5.5V$ ,  $V_{SS} = GND$ ,  $T_A = +25^\circ C$ ,  $V_{CM} = V_{DD}/2$ ,  $V_{OUT} \approx V_{DD}/2$ ,  $V_L = V_{DD}/2$ ,  $R_L = 1\text{ M}\Omega$  to  $V_L$  and  $\overline{CS}$  is tied low. (Refer to [Figure 1-2](#) and [Figure 1-3](#)).

Parameters	Sym	Min	Typ	Max	Units	Conditions
<b>Output</b>						
Maximum Output Voltage Swing	$V_{OL}, V_{OH}$	$V_{SS} + 10$	—	$V_{DD} - 10$	mV	$R_L = 50\text{ k}\Omega$ to $V_L$ , 0.5V input overdrive
Output Short-Circuit Current	$I_{SC}$	—	$\pm 5$	—	mA	$V_{DD} = 1.8V$
		—	$\pm 23$	—	mA	$V_{DD} = 5.5V$
<b>Power Supply</b>						
Supply Voltage	$V_{DD}$	1.8	—	5.5	V	
Quiescent Current per Amplifier	$I_Q$	0.4	0.9	1.35	$\mu A$	$I_O = 0$ , $V_{CM} = V_{DD}$ , $V_{DD} = 5.5V$

## AC ELECTRICAL SPECIFICATIONS

**Electrical Characteristics:** Unless otherwise indicated,  $T_A = +25^\circ C$ ,  $V_{DD} = +1.8$  to  $+5.5V$ ,  $V_{SS} = GND$ ,  $V_{CM} = V_{DD}/2$ ,  $V_{OUT} \approx V_{DD}/2$ ,  $V_L = V_{DD}/2$ ,  $C_L = 60\text{ pF}$ ,  $R_L = 1\text{ M}\Omega$  to  $V_L$  and  $\overline{CS}$  is tied low. (Refer to [Figure 1-2](#) and [Figure 1-3](#)).

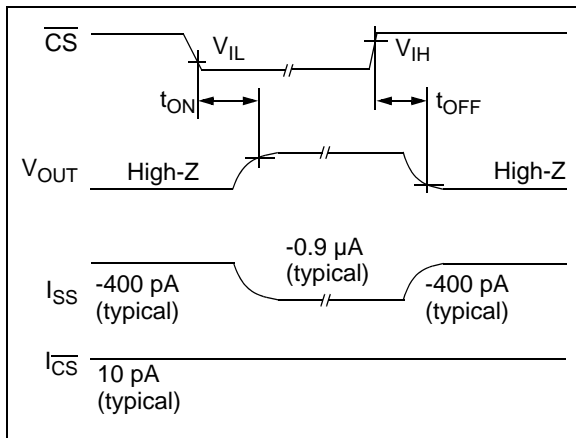
Parameters	Sym	Min	Typ	Max	Units	Conditions
<b>AC Response</b>						
Gain Bandwidth Product	GBWP	—	10	—	kHz	
Phase Margin	PM	—	65	—	$^\circ$	$G = +1\text{ V/V}$
Slew Rate	SR	—	4.0	—	V/ms	
<b>Noise</b>						
Input Noise Voltage	$E_{ni}$	—	3.9	—	$\mu V_{p-p}$	$f = 0.1\text{ Hz}$ to $10\text{ Hz}$
Input Noise Voltage Density	$e_{ni}$	—	165	—	$nV/\sqrt{Hz}$	$f = 1\text{ kHz}$
Input Noise Current Density	$i_{ni}$	—	0.6	—	$fA/\sqrt{Hz}$	$f = 1\text{ kHz}$

# MCP6031/2/3/4

## MCP6033 CHIP SELECT ELECTRICAL CHARACTERISTICS

**Electrical Specifications:** Unless otherwise indicated,  $V_{DD} = +1.8V$  to  $+5.5V$ ,  $V_{SS} = GND$ ,  $T_A = +25^\circ C$ ,  $V_{CM} = V_{DD}/2$ ,  $V_{OUT} = V_{DD}/2$ ,  $V_L = V_{DD}/2$ ,  $C_L = 60$  pF,  $R_L = 1$  M $\Omega$  to  $V_L$  and  $\overline{CS}$  is tied low (Refer to [Figure 1-1](#)).

Parameters	Sym	Min	Typ	Max	Units	Conditions
<b><math>\overline{CS}</math> Low Specifications</b>						
$\overline{CS}$ Logic Threshold, Low	$V_{IL}$	$V_{SS}$	—	$0.2V_{DD}$	V	
$\overline{CS}$ Input Current, Low	$I_{CSL}$	—	-10	—	pA	$\overline{CS} = V_{SS}$
<b><math>\overline{CS}</math> High Specifications</b>						
$\overline{CS}$ Logic Threshold, High	$V_{IH}$	$0.8V_{DD}$		$V_{DD}$	V	
$\overline{CS}$ Input Current, High	$I_{CSH}$	—	10	—	pA	$\overline{CS} = V_{DD}$
GND Current	$I_{SS}$	—	-400	—	pA	$\overline{CS} = V_{DD}$
Amplifier Output Leakage	$I_{O(LEAK)}$	—	10	—	pA	$\overline{CS} = V_{DD}$
<b><math>\overline{CS}</math> Dynamic Specifications</b>						
$\overline{CS}$ Low to Amplifier Output Turn-on Time	$t_{ON}$	—	4	100	ms	$\overline{CS} \leq 0.2V_{DD}$ to $V_{OUT} = 0.9V_{DD}/2$ , $G = +1$ V/V, $V_{IN} = V_{DD}/2$ , $R_L = 50$ k $\Omega$ to $V_L = V_{SS}$ .
$\overline{CS}$ High to Amplifier Output High-Z	$t_{OFF}$	—	10	—	$\mu s$	$\overline{CS} \geq 0.8V_{DD}$ to $V_{OUT} = 0.1V_{DD}/2$ , $G = +1$ V/V, $V_{IN} = V_{DD}/2$ , $R_L = 50$ k $\Omega$ to $V_L = V_{SS}$ .
$\overline{CS}$ Hysteresis	$V_{HYST}$	—	$0.3V_{DD}$	—	V	



**FIGURE 1-1:** Timing Diagram for the  $\overline{CS}$  Pin on the MCP6033.

## TEMPERATURE SPECIFICATIONS

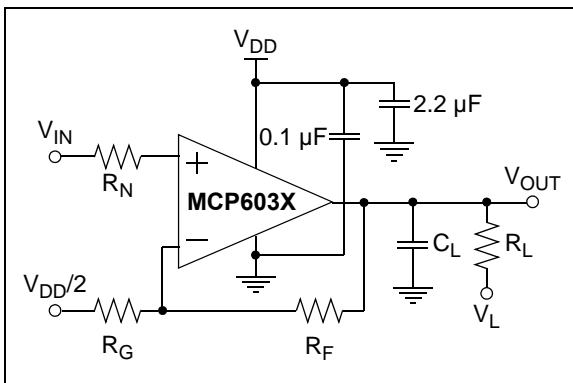
**Electrical Characteristics:** Unless otherwise indicated,  $V_{DD} = +1.8V$  to  $+5.5V$  and  $V_{SS} = GND$ .

Parameters	Sym	Min	Typ	Max	Units	Conditions
<b>Temperature Ranges</b>						
Operating Temperature Range	$T_A$	-40	—	+125	°C	<b>Note</b>
Storage Temperature Range	$T_A$	-65	—	+150	°C	
<b>Thermal Package Resistances</b>						
Thermal Resistance, 5L-SOT-23	$\theta_{JA}$	—	256	—	°C/W	
Thermal Resistance, 8L-DFN (2x3)	$\theta_{JA}$	—	84	—	°C/W	
Thermal Resistance, 8L-SOIC	$\theta_{JA}$	—	163	—	°C/W	
Thermal Resistance, 8L-MSOP	$\theta_{JA}$	—	206	—	°C/W	
Thermal Resistance, 14L-SOIC	$\theta_{JA}$	—	120	—	°C/W	
Thermal Resistance, 14L-TSSOP	$\theta_{JA}$	—	100	—	°C/W	

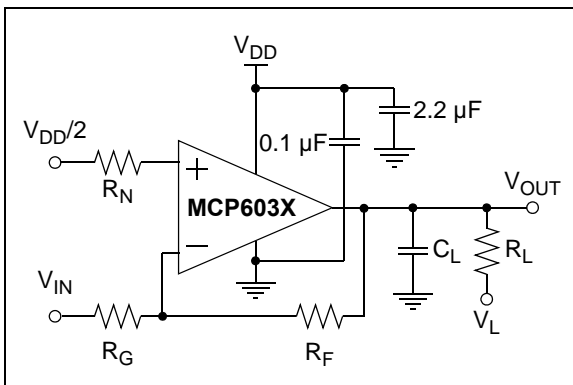
**Note:** The internal junction temperature ( $T_J$ ) must not exceed the absolute maximum specification of  $+150^\circ\text{C}$ .

### 1.1 Test Circuits

The test circuits used for the DC and AC tests are shown in [Figure 1-2](#) and [Figure 1-3](#). The bypass capacitors are laid out according to the rules discussed in [Section 4.6 “Supply Bypass”](#).



**FIGURE 1-2:** AC and DC Test Circuit for Most Non-Inverting Gain Conditions.



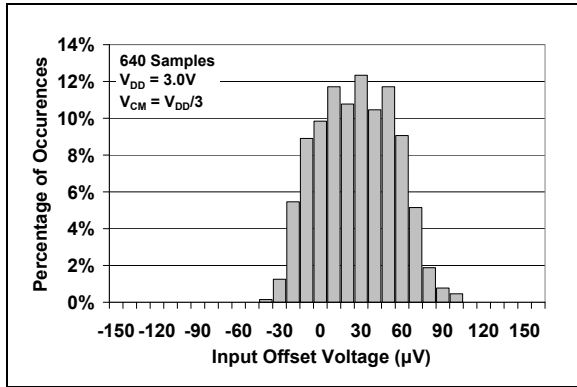
**FIGURE 1-3:** AC and DC Test Circuit for Most Inverting Gain Conditions.

# MCP6031/2/3/4

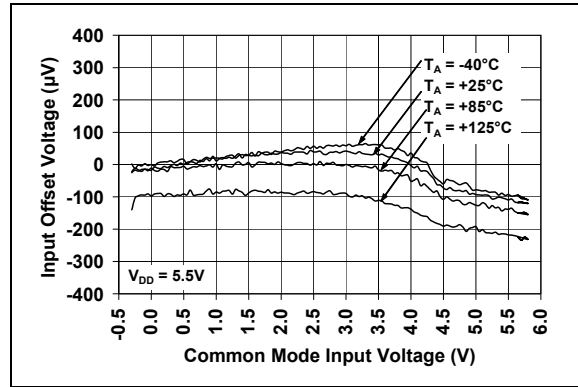
## 2.0 TYPICAL PERFORMANCE CURVES

**Note:** The graphs and tables provided following this note are a statistical summary based on a limited number of samples and are provided for informational purposes only. The performance characteristics listed herein are not tested or guaranteed. In some graphs or tables, the data presented may be outside the specified operating range (e.g., outside specified power supply range) and therefore outside the warranted range.

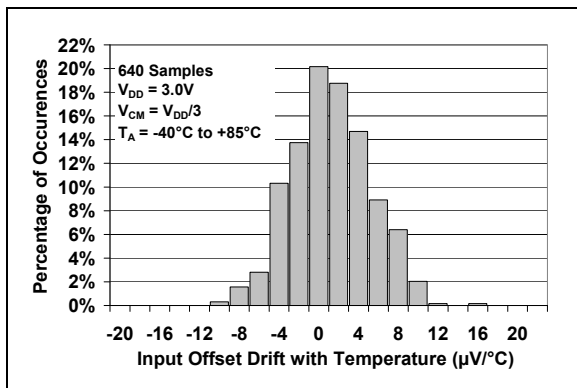
**Note:** Unless otherwise indicated,  $T_A = +25^\circ\text{C}$ ,  $V_{DD} = +1.8\text{V}$  to  $+5.5\text{V}$ ,  $V_{SS} = \text{GND}$ ,  $V_{CM} = V_{DD}/2$ ,  $V_{OUT} \approx V_{DD}/2$ ,  $V_L = V_{DD}/2$ ,  $R_L = 1\text{ M}\Omega$  to  $V_L$ ,  $C_L = 60\text{ pF}$  and CS is tied low.



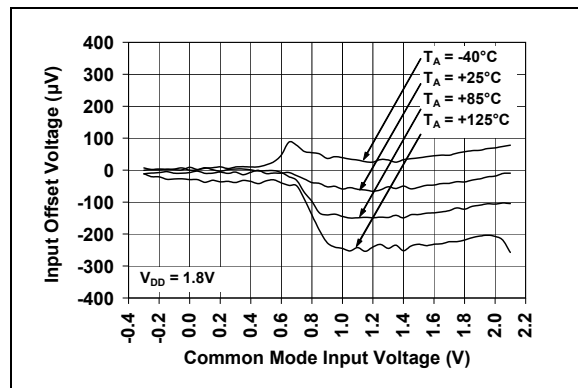
**FIGURE 2-1:** Input Offset Voltage with  $V_{DD} = 3.0\text{V}$ .



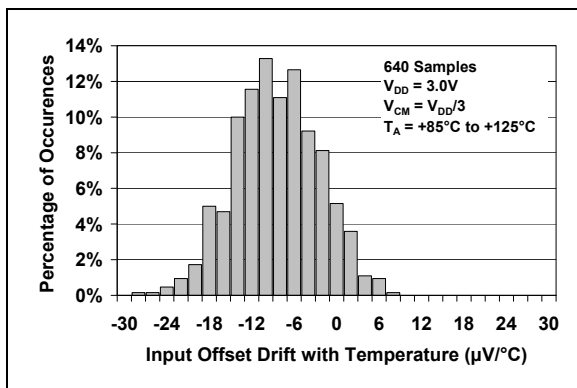
**FIGURE 2-4:** Input Offset Voltage vs. Common Mode Input Voltage with  $V_{DD} = 5.5\text{V}$ .



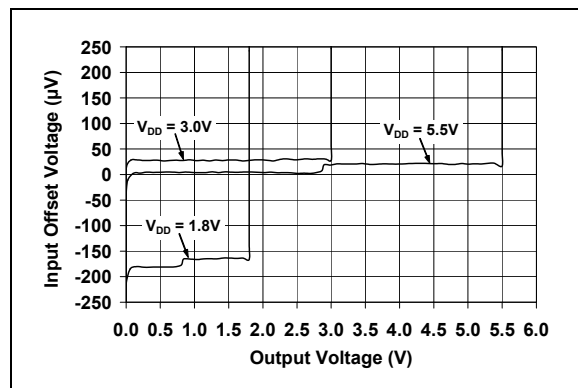
**FIGURE 2-2:** Input Offset Voltage Drift with  $V_{DD} = 3.0\text{V}$  and  $T_A \leq +85^\circ\text{C}$ .



**FIGURE 2-5:** Input Offset Voltage vs. Common Mode Input Voltage with  $V_{DD} = 1.8\text{V}$ .

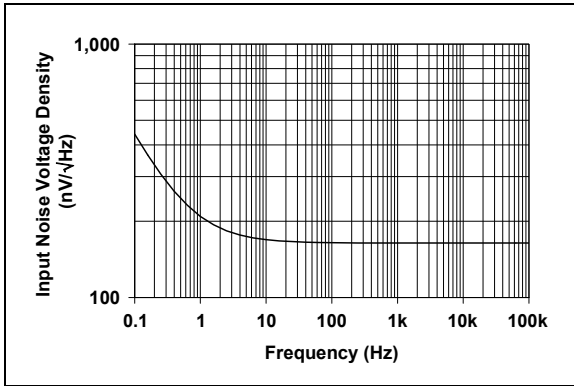


**FIGURE 2-3:** Input Offset Voltage Drift with  $V_{DD} = 3.0\text{V}$  and  $T_A \geq +85^\circ\text{C}$ .

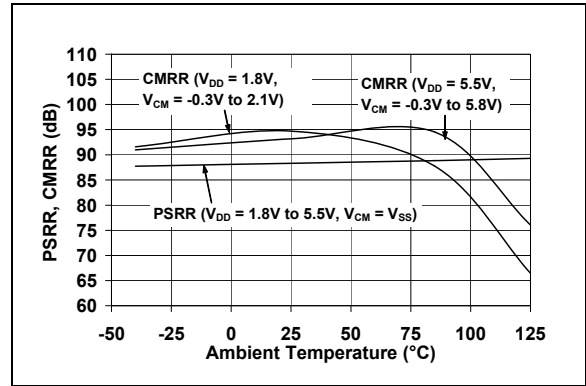


**FIGURE 2-6:** Input Offset Voltage vs. Output Voltage.

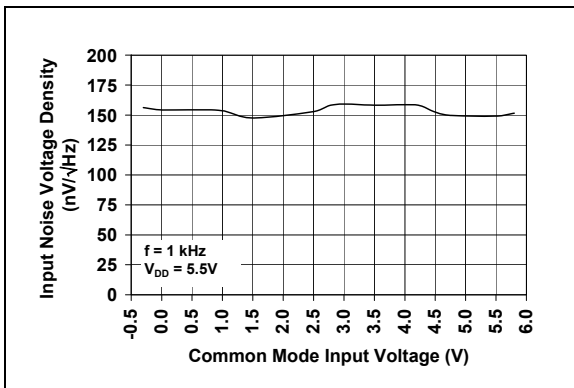
**Note:** Unless otherwise indicated,  $T_A = +25^\circ\text{C}$ ,  $V_{DD} = +1.8\text{V}$  to  $+5.5\text{V}$ ,  $V_{SS} = \text{GND}$ ,  $V_{CM} = V_{DD}/2$ ,  $V_{OUT} \approx V_{DD}/2$ ,  $V_L = V_{DD}/2$ ,  $R_L = 1\text{ M}\Omega$  to  $V_L$ ,  $C_L = 60\text{ pF}$  and  $\text{CS}$  is tied low.



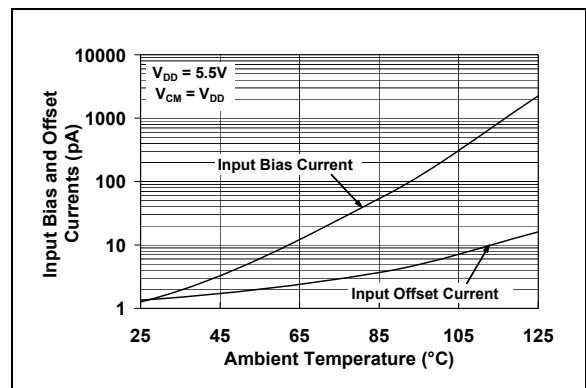
**FIGURE 2-7:** Input Noise Voltage Density vs. Frequency.



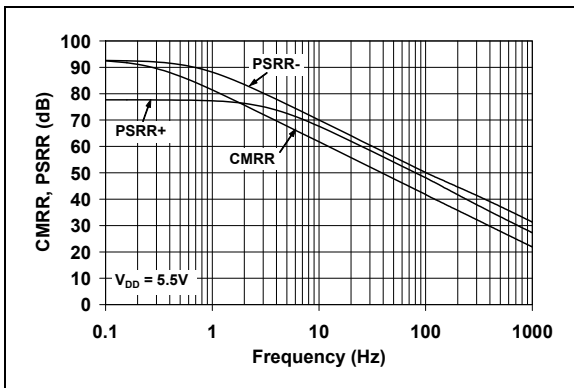
**FIGURE 2-10:** Common Mode Rejection Ratio, Power Supply Rejection Ratio vs. Ambient Temperature.



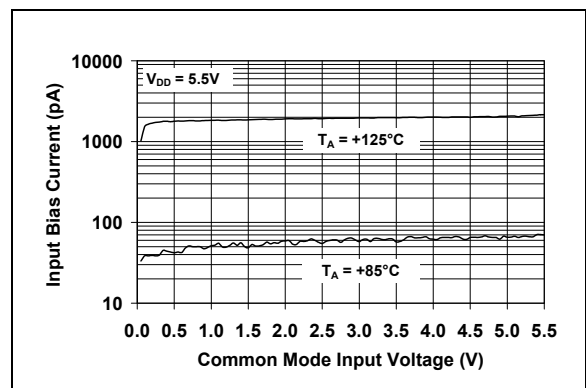
**FIGURE 2-8:** Input Noise Voltage Density vs. Common Mode Input Voltage.



**FIGURE 2-11:** Input Bias, Offset Currents vs. Ambient Temperature.



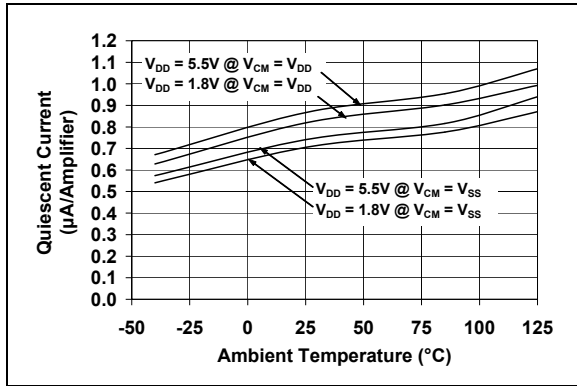
**FIGURE 2-9:** Common Mode Rejection Ratio, Power Supply Rejection Ratio vs. Frequency.



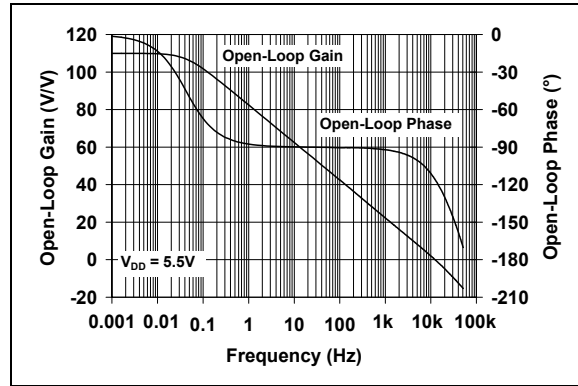
**FIGURE 2-12:** Input Bias Current vs. Common Mode Input Voltage.

# MCP6031/2/3/4

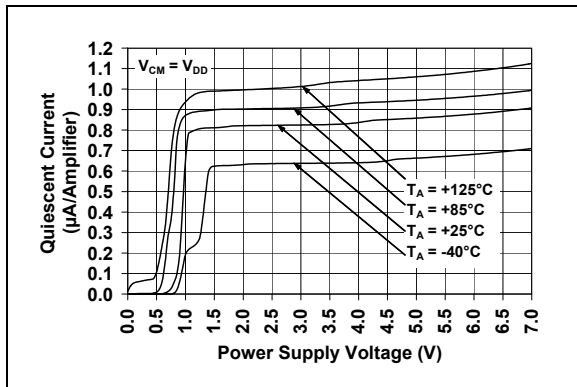
**Note:** Unless otherwise indicated,  $T_A = +25^\circ\text{C}$ ,  $V_{DD} = +1.8\text{V}$  to  $+5.5\text{V}$ ,  $V_{SS} = \text{GND}$ ,  $V_{CM} = V_{DD}/2$ ,  $V_{OUT} \approx V_{DD}/2$ ,  $V_L = V_{DD}/2$ ,  $R_L = 1\text{ M}\Omega$  to  $V_L$ ,  $C_L = 60\text{ pF}$  and CS is tied low.



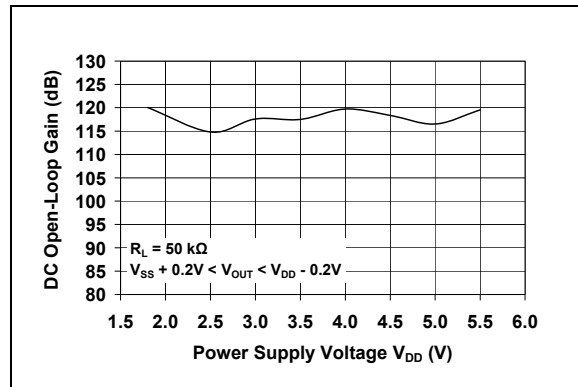
**FIGURE 2-13:** Quiescent Current vs Ambient Temperature.



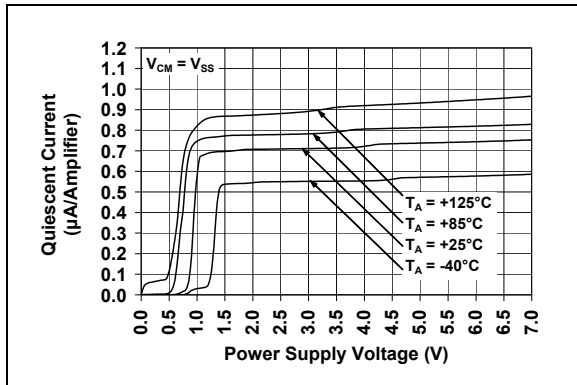
**FIGURE 2-16:** Open-Loop Gain, Phase vs. Frequency.



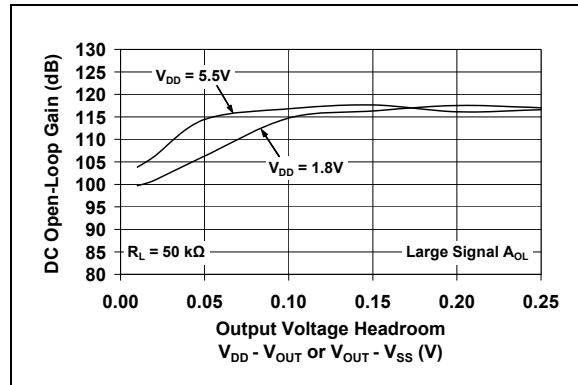
**FIGURE 2-14:** Quiescent Current vs. Power Supply Voltage with  $V_{CM} = V_{DD}$ .



**FIGURE 2-17:** DC Open-Loop Gain vs. Power Supply Voltage.

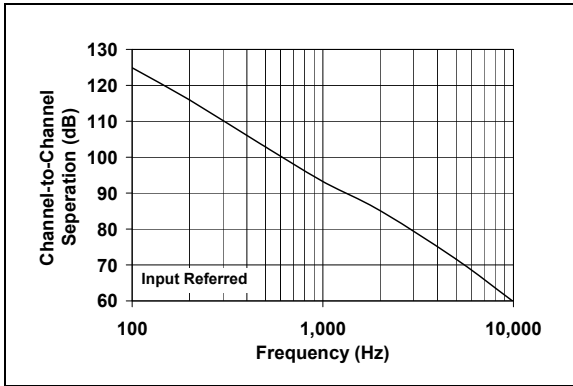


**FIGURE 2-15:** Quiescent Current vs. Power Supply Voltage with  $V_{CM} = V_{SS}$ .

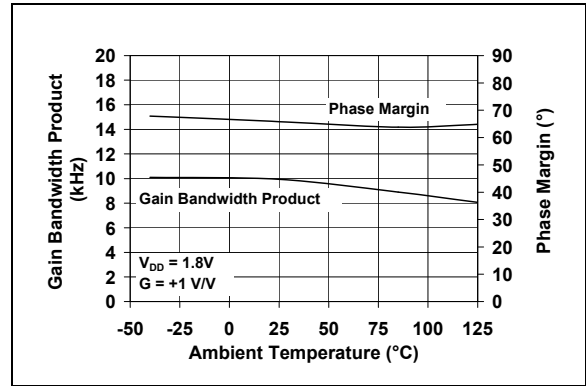


**FIGURE 2-18:** DC Open-Loop Gain vs. Output Voltage Headroom.

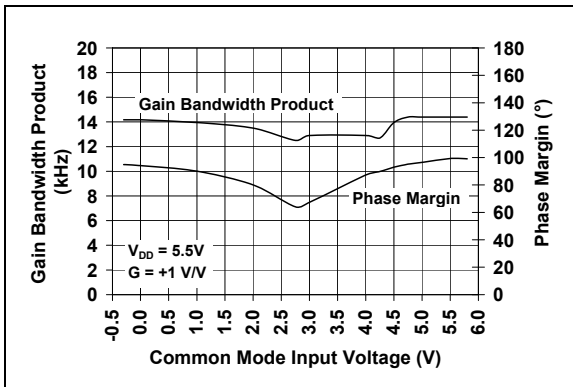
**Note:** Unless otherwise indicated,  $T_A = +25^\circ\text{C}$ ,  $V_{DD} = +1.8\text{V}$  to  $+5.5\text{V}$ ,  $V_{SS} = \text{GND}$ ,  $V_{CM} = V_{DD}/2$ ,  $V_{OUT} \approx V_{DD}/2$ ,  $V_L = V_{DD}/2$ ,  $R_L = 1\text{ M}\Omega$  to  $V_L$ ,  $C_L = 60\text{ pF}$  and CS is tied low.



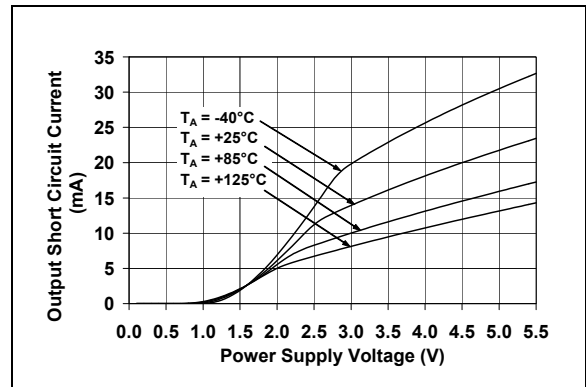
**FIGURE 2-19:** Channel-to-Channel Separation vs. Frequency (MCP6032/4 only).



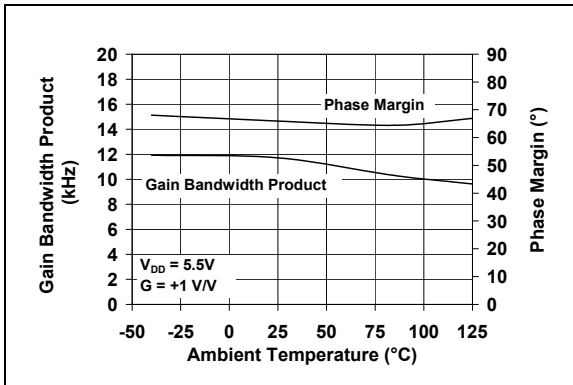
**FIGURE 2-22:** Gain Bandwidth Product, Phase Margin vs. Ambient Temperature.



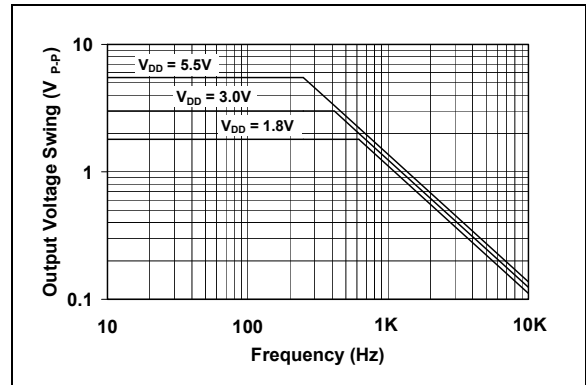
**FIGURE 2-20:** Gain Bandwidth Product, Phase Margin vs. Common Mode Input Voltage.



**FIGURE 2-23:** Output Short Circuit Current vs. Power Supply Voltage.



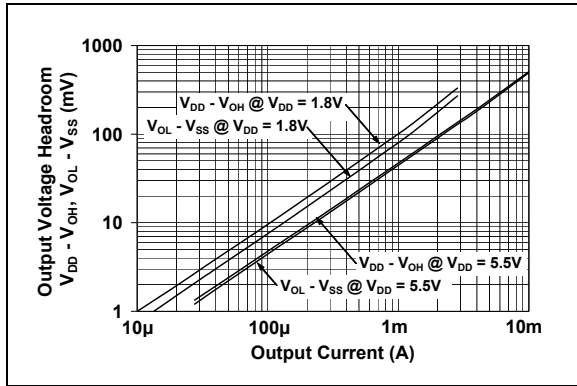
**FIGURE 2-21:** Gain Bandwidth Product, Phase Margin vs. Ambient Temperature.



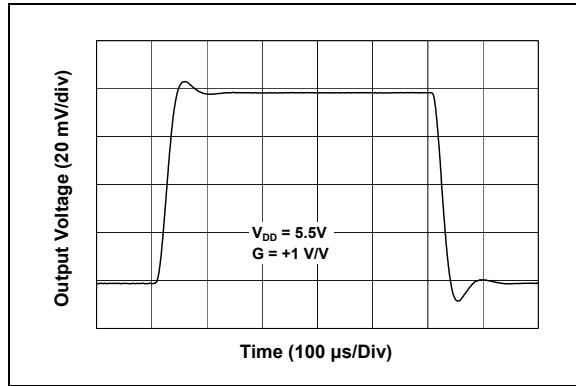
**FIGURE 2-24:** Output Voltage Swing vs. Frequency.

# MCP6031/2/3/4

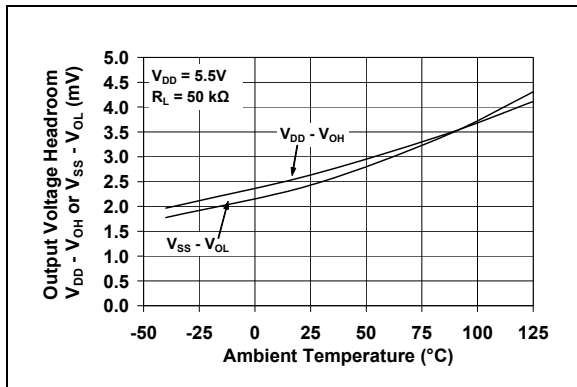
**Note:** Unless otherwise indicated,  $T_A = +25^\circ\text{C}$ ,  $V_{DD} = +1.8\text{V}$  to  $+5.5\text{V}$ ,  $V_{SS} = \text{GND}$ ,  $V_{CM} = V_{DD}/2$ ,  $V_{OUT} \approx V_{DD}/2$ ,  $V_L = V_{DD}/2$ ,  $R_L = 1\text{ M}\Omega$  to  $V_L$ ,  $C_L = 60\text{ pF}$  and  $CS$  is tied low.



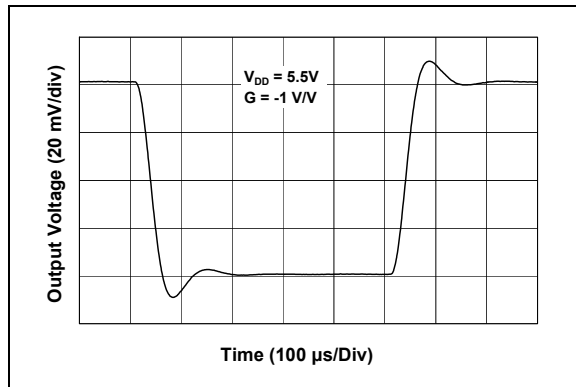
**FIGURE 2-25:** Output Voltage Headroom vs. Output Current.



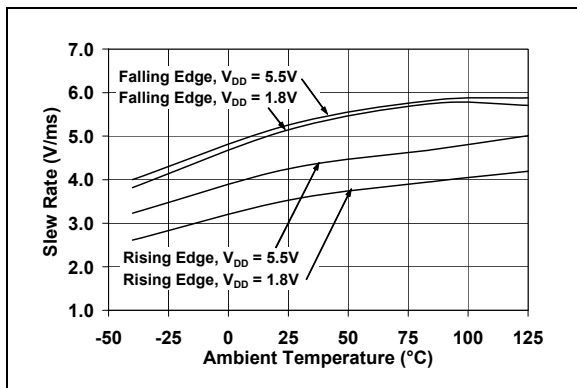
**FIGURE 2-28:** Small Signal Non-Inverting Pulse Response.



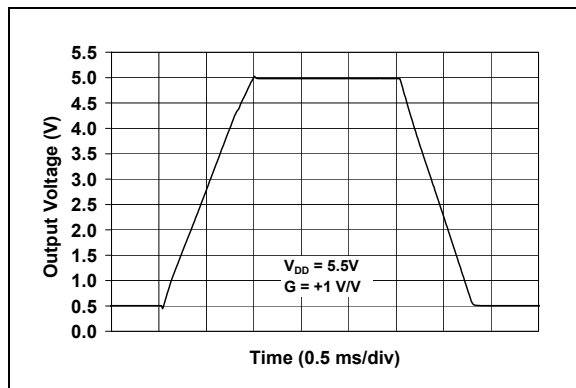
**FIGURE 2-26:** Output Voltage Headroom vs. Ambient Temperature.



**FIGURE 2-29:** Small Signal Inverting Pulse Response.

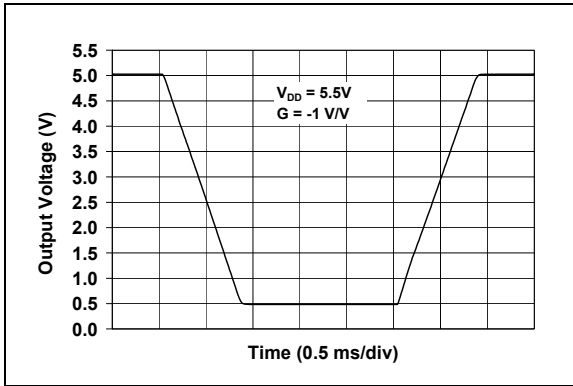


**FIGURE 2-27:** Slew Rate vs. Ambient Temperature.

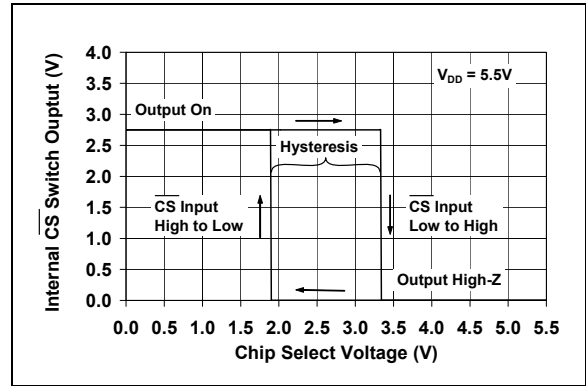


**FIGURE 2-30:** Large Signal Non-Inverting Pulse Response.

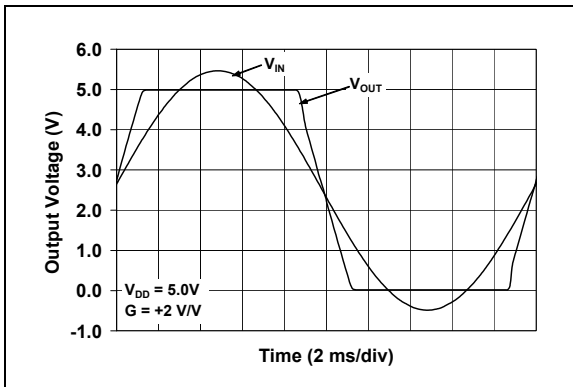
**Note:** Unless otherwise indicated,  $T_A = +25^\circ\text{C}$ ,  $V_{DD} = +1.8\text{V}$  to  $+5.5\text{V}$ ,  $V_{SS} = \text{GND}$ ,  $V_{CM} = V_{DD}/2$ ,  $V_{OUT} \approx V_{DD}/2$ ,  $V_L = V_{DD}/2$ ,  $R_L = 1\text{ M}\Omega$  to  $V_L$ ,  $C_L = 60\text{ pF}$  and CS is tied low.



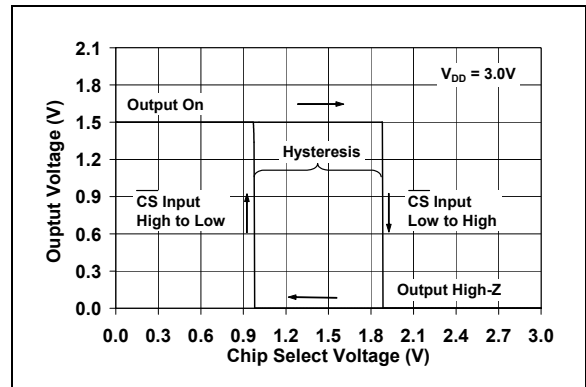
**FIGURE 2-31:** Large Signal Inverting Pulse Response.



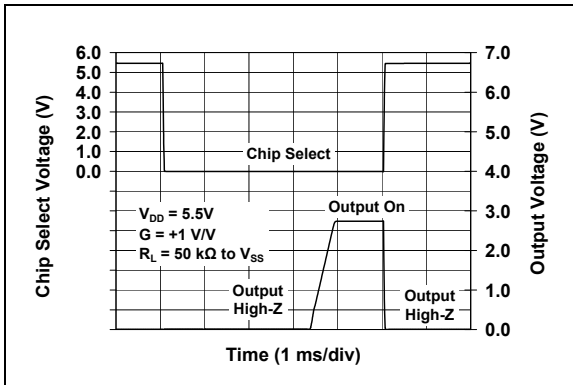
**FIGURE 2-34:** Chip Select ( $\overline{\text{CS}}$ ) Hysteresis (MCP6033 only) with  $V_{DD} = 5.5\text{V}$ .



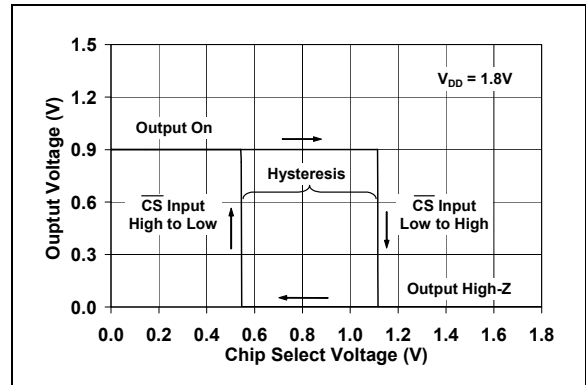
**FIGURE 2-32:** The MCP6031/2/3/4 family shows no phase reversal.



**FIGURE 2-35:** Chip Select ( $\overline{\text{CS}}$ ) Hysteresis (MCP6033 only) with  $V_{DD} = 3.0\text{V}$ .



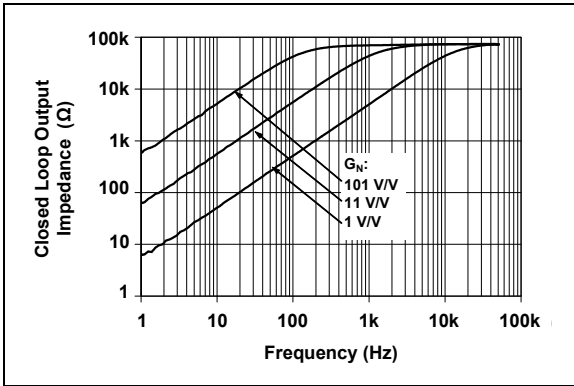
**FIGURE 2-33:** Chip Select ( $\overline{\text{CS}}$ ) to Amplifier Output Response Time (MCP6033 only).



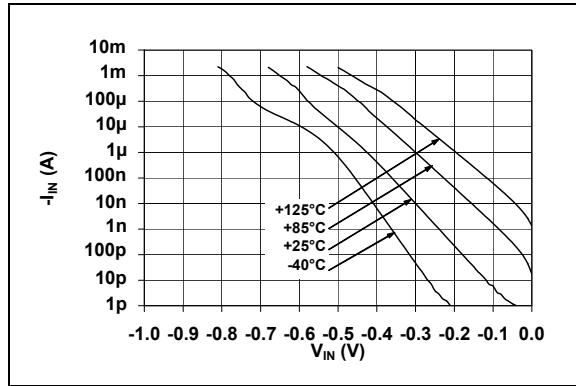
**FIGURE 2-36:** Chip Select ( $\overline{\text{CS}}$ ) Hysteresis (MCP6033 only) with  $V_{DD} = 1.8\text{V}$ .

# MCP6031/2/3/4

**Note:** Unless otherwise indicated,  $T_A = +25^\circ\text{C}$ ,  $V_{DD} = +1.8\text{V}$  to  $+5.5\text{V}$ ,  $V_{SS} = \text{GND}$ ,  $V_{CM} = V_{DD}/2$ ,  $V_{OUT} \approx V_{DD}/2$ ,  $V_L = V_{DD}/2$ ,  $R_L = 1\text{ M}\Omega$  to  $V_L$ ,  $C_L = 60\text{ pF}$  and  $\text{CS}$  is tied low.



**FIGURE 2-37:** Closed Loop Output Impedance vs. Frequency.



**FIGURE 2-38:** Measured Input Current vs. Input Voltage (below  $V_{SS}$ ).

## 3.0 PIN DESCRIPTIONS

Descriptions of the pins are listed in [Table 3-1](#).

**TABLE 3-1: PIN FUNCTION TABLE**

MCP6031		MCP6032	MCP6033	MCP6034	Symbol	Description
SOT-23-5	DFN, MSOP, SOIC	MSOP, SOIC	DFN, MSOP, SOIC	SOIC, TSSOP		
1	6	1	6	1	$V_{OUT}, V_{OUTA}$	Analog Output (op amp A)
4	2	2	2	2	$V_{IN}^-, V_{INA}^-$	Inverting Input (op amp A)
3	3	3	3	3	$V_{IN}^+, V_{INA}^+$	Non-inverting Input (op amp A)
5	7	8	7	4	$V_{DD}$	Positive Power Supply
—	—	5	—	5	$V_{INB}^+$	Non-inverting Input (op amp B)
—	—	6	—	6	$V_{INB}^-$	Inverting Input (op amp B)
—	—	7	—	7	$V_{OUTB}$	Analog Output (op amp B)
—	—	—	—	8	$V_{OUTC}$	Analog Output (op amp C)
—	—	—	—	9	$V_{INC}^-$	Inverting Input (op amp C)
—	—	—	—	10	$V_{INC}^+$	Non-inverting Input (op amp C)
2	4	4	4	11	$V_{SS}$	Negative Power Supply
—	—	—	—	12	$V_{IND}^+$	Non-inverting Input (op amp D)
—	—	—	—	13	$V_{IND}^-$	Inverting Input (op amp D)
—	—	—	—	14	$V_{OUTD}$	Analog Output (op amp D)
—	—	—	8	—	$\overline{CS}$	Chip Select
—	1, 5, 8	—	1, 5	—	NC	No Internal Connection

### 3.1 Analog Outputs

The output pins are low-impedance voltage sources.

### 3.2 Analog Inputs

The non-inverting and inverting inputs are high-impedance CMOS inputs with low bias currents.

### 3.3 Chip Select Digital Input

This is a CMOS, Schmitt-triggered input that places the device into a low power mode of operation.

### 3.4 Power Supply Pins

The positive power supply ( $V_{DD}$ ) is 1.8V to 5.5V higher than the negative power supply ( $V_{SS}$ ). For normal operation, the other pins are at voltages between  $V_{SS}$  and  $V_{DD}$ .

Typically, these parts are used in a single (positive) supply configuration. In this case,  $V_{SS}$  is connected to ground and  $V_{DD}$  is connected to the supply.  $V_{DD}$  will need bypass capacitors.

# MCP6031/2/3/4

## 4.0 APPLICATION INFORMATION

The MCP6031/2/3/4 family of op amps is manufactured using Microchip's state-of-the-art CMOS process and is specifically designed for low-power, high precision applications.

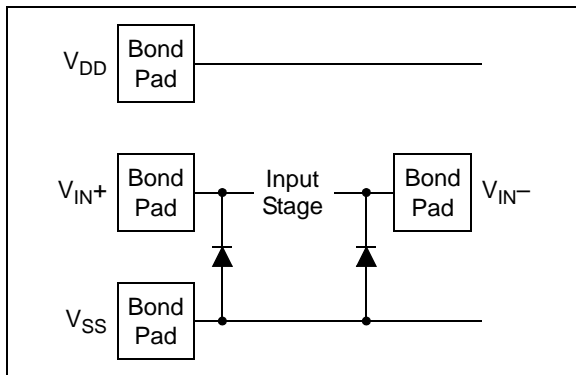
### 4.1 Rail-to-Rail Input

#### 4.1.1 PHASE REVERSAL

The MCP6031/2/3/4 op amps are designed to prevent phase reversal when the input pins exceed the supply voltages. Figure 2-32 shows the input voltage exceeding the supply voltage without any phase reversal.

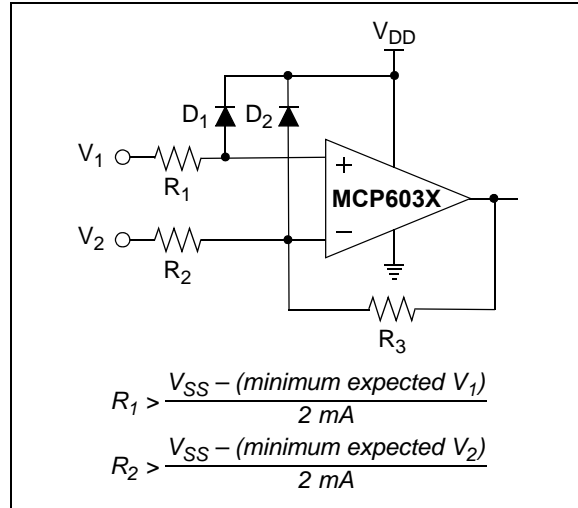
#### 4.1.2 INPUT VOLTAGE AND CURRENT LIMITS

The ESD protection on the inputs can be depicted as shown in Figure 4-1. This structure was chosen to protect the input transistors and to minimize input bias current ( $I_B$ ). The input ESD diodes clamp the inputs when they try to go more than one diode drop below  $V_{SS}$ . They also clamp any voltage that goes too far above  $V_{DD}$ ; their breakdown voltage is high enough to allow normal operation and low enough to bypass ESD events within the specified limits.



**FIGURE 4-1:** Simplified Analog Input ESD Structures.

In order to prevent damage and/or improper operation of these op amps, the circuit they are in must limit the voltages and currents at the  $V_{IN+}$  and  $V_{IN-}$  pins (see **Absolute Maximum Ratings** at the beginning of **Section 1.0 "Electrical Characteristics"**). Figure 4-2 shows the recommended approach to protecting these inputs. The internal ESD diodes prevent the input pins ( $V_{IN+}$  and  $V_{IN-}$ ) from going too far below ground, and the resistors  $R_1$  and  $R_2$  limit the possible current drawn out of the input pins. Diodes  $D_1$  and  $D_2$  prevent the input pins ( $V_{IN+}$  and  $V_{IN-}$ ) from going too far above  $V_{DD}$ . When implemented as shown, resistors  $R_1$  and  $R_2$  also limit the current through  $D_1$  and  $D_2$ .



**FIGURE 4-2:** Protecting the Analog Inputs.

It is also possible to connect the diodes to the left of the resistors  $R_1$  and  $R_2$ . In this case, the currents through the diodes  $D_1$  and  $D_2$  need to be limited by some other mechanism. The resistors then serve as in-rush current limiters; the DC currents into the input pins ( $V_{IN+}$  and  $V_{IN-}$ ) should be very small. A significant amount of current can flow out of the inputs when the common mode voltage ( $V_{CM}$ ) is below ground ( $V_{SS}$ ).

#### 4.1.3 NORMAL OPERATION

The input stage of the MCP6031/2/3/4 op amps uses two differential input stages in parallel. One operates at a low common mode input voltage ( $V_{CM}$ ), while the other operates at a high  $V_{CM}$ . With this topology, the device operates with a  $V_{CM}$  up to 300 mV above  $V_{DD}$  and 300 mV below  $V_{SS}$ . The input offset voltage is measured at  $V_{CM} = V_{SS} - 0.3V$  and  $V_{DD} + 0.3V$  to ensure proper operation.

There are two transitions in input behavior as  $V_{CM}$  is changed. The first occurs, when  $V_{CM}$  is near  $V_{SS} + 0.4V$ , and the second occurs when  $V_{CM}$  is near  $V_{DD} - 0.5V$ . For the best distortion performance with non-inverting gains, avoid these regions of operation.

## 4.2 Rail-to-Rail Output

The output voltage range of the MCP6031/2/3/4 op amps is  $V_{SS} + 10\text{ mV}$  (minimum) and  $V_{DD} - 10\text{ mV}$  (maximum) when  $R_L = 50\text{ k}\Omega$  is connected to  $V_{DD}/2$  and  $V_{DD} = 5.5\text{ V}$ . Refer to Figures 2-25 and 2-26 for more information.

## 4.3 Output Loads and Battery Life

The MCP6031/2/3/4 op amp family has outstanding quiescent current, which supports battery-powered applications. There is minimal quiescent current glitching when Chip Select ( $\overline{\text{CS}}$ ) is raised or lowered. This prevents excessive current draw, and reduced battery life, when the part is turned off or on.

Heavy resistive loads at the output can cause excessive battery drain. Driving a DC voltage of 2.5V across a 100 k $\Omega$  load resistor will cause the supply current to increase by 25  $\mu\text{A}$ , depleting the battery 28 times as fast as  $I_Q$  (0.9  $\mu\text{A}$ , typical) alone.

High frequency signals (fast edge rate) across capacitive loads will also significantly increase supply current. For instance, a 0.1  $\mu\text{F}$  capacitor at the output presents an AC impedance of 15.9 k $\Omega$  ( $1/2\pi fC$ ) to a 100 Hz sine wave. It can be shown that the average power drawn from the battery by a 5.0  $V_{p-p}$  sine wave (1.77  $V_{rms}$ ), under these conditions, is

### EQUATION 4-1:

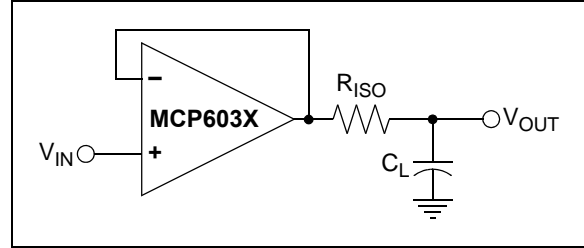
$$\begin{aligned} P_{Supply} &= (V_{DD} - V_{SS}) (I_Q + V_{L(p-p)} f C_L) \\ &= (5V)(0.9\ \mu\text{A} + 5.0V_{p-p} \cdot 100\text{Hz} \cdot 0.1\ \mu\text{F}) \\ &= 4.5\ \mu\text{W} + 50\ \mu\text{W} \end{aligned}$$

This will drain the battery about 12 times as fast as  $I_Q$  alone.

## 4.4 Capacitive Loads

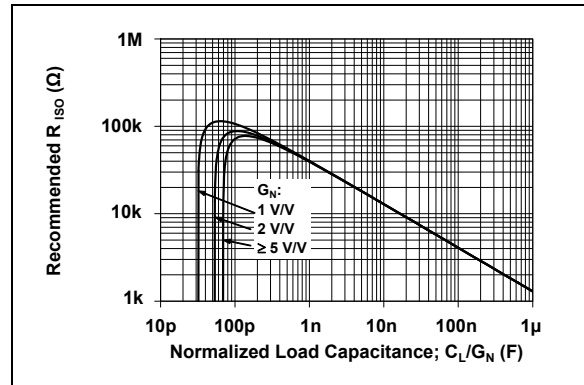
Driving large capacitive loads can cause stability problems for voltage feedback op amps. As the load capacitance increases, the feedback loop's phase margin decreases and the closed-loop bandwidth is reduced. This produces gain peaking in the frequency response, with overshoot and ringing in the step response. While a unity-gain buffer ( $G = +1$ ) is the most sensitive to capacitive loads, all gains show the same general behavior.

When driving large capacitive loads with these op amps (e.g., > 100 pF when  $G = +1$ ), a small series resistor at the output ( $R_{ISO}$  in Figure 4-3) improves the feedback loop's phase margin (stability) by making the output load resistive at higher frequencies. The bandwidth will be generally lower than the bandwidth with no capacitance load.



**FIGURE 4-3:** Output resistor,  $R_{ISO}$  stabilizes large capacitive loads.

Figure 4-4 gives recommended  $R_{ISO}$  values for different capacitive loads and gains. The x-axis is the normalized load capacitance ( $C_L/G_N$ ), where  $G_N$  is the circuit's noise gain. For non-inverting gains,  $G_N$  and the Signal Gain are equal. For inverting gains,  $G_N = 1 + |\text{Signal Gain}|$  (e.g., -1 V/V gives  $G_N = +2\text{ V/V}$ ).



**FIGURE 4-4:** Recommended  $R_{ISO}$  values for Capacitive Loads.

After selecting  $R_{ISO}$  for your circuit, double-check the resulting frequency response peaking and step response overshoot. Modify  $R_{ISO}$ 's value until the response is reasonable. Bench evaluation and simulations with the MCP6031/2/3/4 SPICE macro model are very helpful.

## 4.5 MCP6033 Chip Select

The MCP6033 is a single op amp with Chip Select ( $\overline{\text{CS}}$ ). When  $\overline{\text{CS}}$  is pulled high, the supply current drops to 0.4 nA (typical) and flows through the  $\overline{\text{CS}}$  pin to  $V_{SS}$ . When this happens, the amplifier output is put into a high impedance state. By pulling  $\overline{\text{CS}}$  low, the amplifier is enabled. If the  $\overline{\text{CS}}$  pin is left floating, the amplifier will not operate properly. Figure 1-1 shows the output voltage and supply current response to a  $\overline{\text{CS}}$  pulse.

# MCP6031/2/3/4

## 4.6 Supply Bypass

With this family of operational amplifiers, the power supply pin ( $V_{DD}$  for single-supply) should have a local bypass capacitor (i.e., 0.01  $\mu\text{F}$  to 0.1  $\mu\text{F}$ ) within 2 mm for good high frequency performance. It can use a bulk capacitor (i.e., 1  $\mu\text{F}$  or larger) within 100 mm to provide large, slow currents. This bulk capacitor can be shared with other analog parts.

## 4.7 Unused Op Amps

An unused op amp in a quad package (MCP6034) should be configured as shown in Figure 4-5. These circuits prevent the output from toggling and causing crosstalk. Circuit A sets the op amp at its minimum noise gain. The resistor divider produces any desired reference voltage within the output voltage range of the op amp; the op amp buffers that reference voltage. Circuit B uses the minimum number of components and operates as a comparator, but it may draw more current.

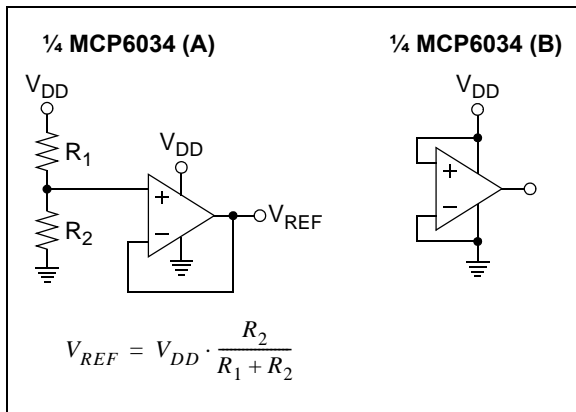


FIGURE 4-5: Unused Op Amps.

## 4.8 PCB Surface Leakage

In applications where low input bias current is critical, Printed Circuit Board (PCB) surface leakage effects need to be considered. Surface leakage is caused by humidity, dust or other contamination on the board. Under low humidity conditions, a typical resistance between nearby traces is  $10^{12}\Omega$ . A 5V difference would cause 5 pA of current to flow; which is greater than the MCP6031/2/3/4 family's bias current at +25°C ( $\pm 1.0$  pA, typical).

The easiest way to reduce surface leakage is to use a guard ring around sensitive pins (or traces). The guard ring is biased at the same voltage as the sensitive pin. An example of this type of layout is shown in Figure 4-6.

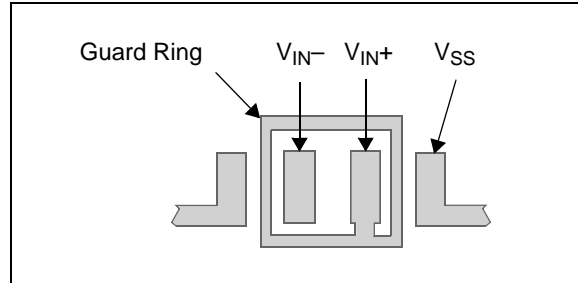


FIGURE 4-6: Example Guard Ring Layout for Inverting Gain.

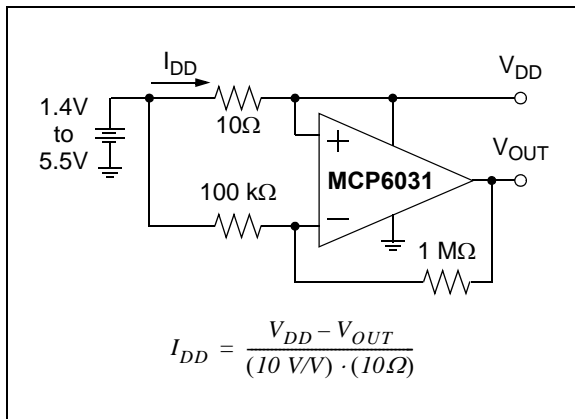
1. Non-inverting Gain and Unity-Gain Buffer:
  - a. Connect the non-inverting pin ( $V_{IN+}$ ) to the input with a wire that does not touch the PCB surface.
  - b. Connect the guard ring to the inverting input pin ( $V_{IN-}$ ). This biases the guard ring to the common mode input voltage.
2. Inverting Gain and Transimpedance Gain Amplifiers (convert current to voltage, such as photo detectors):
  - a. Connect the guard ring to the non-inverting input pin ( $V_{IN+}$ ). This biases the guard ring to the same reference voltage as the op amp (e.g.,  $V_{DD}/2$  or ground).
  - b. Connect the inverting pin ( $V_{IN-}$ ) to the input with a wire that does not touch the PCB surface.

## 4.9 Application Circuits

### 4.9.1 BATTERY CURRENT SENSING

The MCP6031/2/3/4 op amps' Common Mode Input Range, which goes 0.3V beyond both supply rails, supports their use in high side and low side battery current sensing applications. The ultra low quiescent current (0.9  $\mu$ A, typical) helps prolong battery life, and the rail-to-rail output supports detection of low currents.

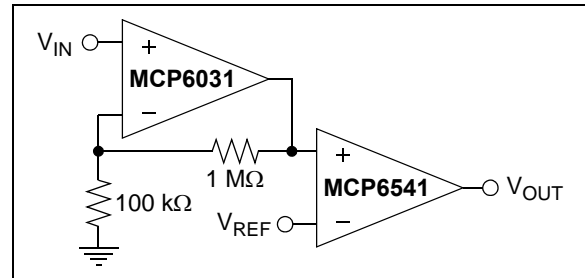
Figure 4-7 shows a high side battery current sensor circuit. The 10 $\Omega$  resistor is sized to minimize power losses. The battery current ( $I_{DD}$ ) through the 10 $\Omega$  resistor causes its top terminal to be more negative than the bottom terminal. This keeps the common mode input voltage of the op amp below  $V_{DD}$ , which is within its allowed range. The output of the op amp will also be below  $V_{DD}$ , which is within its Maximum Output Voltage Swing specification.



**FIGURE 4-7:** High Side Battery Current Sensor.

### 4.9.2 PRECISION COMPARATOR

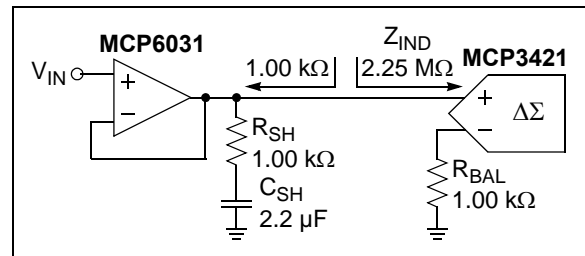
Use high gain before a comparator to improve the latter's input offset performance. Figure 4-8 shows a gain of 11 V/V placed before a comparator. The reference voltage  $V_{REF}$  can be any value between the supply rails.



**FIGURE 4-8:** Precision, Non-inverting Comparator.

### 4.9.3 DRIVING MCP3421 $\Delta\Sigma$ A/D CONVERTER

A  $R_{SH}$  and  $C_{SH}$  snubber reduces the output impedance of MCP6031 op amp, which reduces the gain error caused by switching transients, which occur at the MCP3421 ADC's sampling rate. The snubber also maintains feedback stability and avoids AC response peaking and step response overshoot and ringing (caused by the op amp's inductive output impedance resonating with the ADC's input capacitance). The cost for this improvement is low. Best of all, using an op amp with higher supply current is avoided. See Figure 4-9. This figure also includes a resistor to balance the impedance at the ADC's inputs ( $R_{BAL}$ ) at the sampling frequency; it may not be needed in all designs.



**FIGURE 4-9:** Driving the MCP3421 using an R-C Snubber.

## 5.0 DESIGN AIDS

Microchip provides the basic design tools needed for the MCP6031/2/3/4 family of op amps.

### 5.1 SPICE Macro Model

The latest SPICE macro model for the MCP6031/2/3/4 op amps is available on the Microchip web site at [www.microchip.com](http://www.microchip.com). This model is intended to be an initial design tool that works well in the op amp's linear region of operation over the temperature range. See the model file for information on its capabilities.

Bench testing is a very important part of any design and cannot be replaced with simulations. Also, simulation results using this macro model need to be validated by comparing them to the data sheet specifications and characteristic curves.

### 5.2 FilterLab<sup>®</sup> Software

Microchip's FilterLab<sup>®</sup> software is an innovative software tool that simplifies analog active filter (using op amps) design. Available at no cost from the Microchip web site at [www.microchip.com/filterlab](http://www.microchip.com/filterlab), the FilterLab design tool provides full schematic diagrams of the filter circuit with component values. It also outputs the filter circuit in SPICE format, which can be used with the macro model to simulate actual filter performance.

### 5.3 Mindi<sup>™</sup> Circuit Designer & Simulator

Microchip's Mindi<sup>™</sup> Circuit Designer & Simulator aids in the design of various circuits useful for active filter, amplifier and power-management applications. It is a free online circuit designer & simulator available from the Microchip web site at [www.microchip.com/mindi](http://www.microchip.com/mindi). This interactive circuit designer & simulator enables designers to quickly generate circuit diagrams, simulate circuits. Circuits developed using the Mindi Circuit Designer & Simulator can be downloaded to a personal computer or workstation.

### 5.4 MAPS (Microchip Advanced Part Selector)

MAPS is a software tool that helps semiconductor professionals efficiently identify Microchip devices that fit a particular design requirement. Available at no cost from the Microchip website at [www.microchip.com/maps](http://www.microchip.com/maps), the MAPS is an overall selection tool for Microchip's product portfolio that includes Analog, Memory, MCUs and DSCs. Using this tool you can define a filter to sort features for a parametric search of devices and export side-by-side technical comparison reports. Helpful links are also provided for Datasheets, Purchase, and Sampling of Microchip parts.

## 5.5 Analog Demonstration and Evaluation Boards

Microchip offers a broad spectrum of Analog Demonstration and Evaluation Boards that are designed to help you achieve faster time to market. For a complete listing of these boards and their corresponding user's guides and technical information, visit the Microchip web site at [www.microchip.com/analogtools](http://www.microchip.com/analogtools).

Two of our boards that are especially useful are:

- **P/N SOIC8EV:** *8-Pin SOIC/MSOP/TSSOP/DIP Evaluation Board*
- **P/N SOIC14EV:** *14-Pin SOIC/TSSOP/DIP Evaluation Board*

## 5.6 Application Notes

The following Microchip Analog Design Note and Application Notes are available on the Microchip web site at [www.microchip.com/appnotes](http://www.microchip.com/appnotes) and are recommended as supplemental reference resources.

**ADN003:** *"Select the Right Operational Amplifier for your Filtering Circuits"*, DS21821

**AN722:** *"Operational Amplifier Topologies and DC Specifications"*, DS00722

**AN723:** *"Operational Amplifier AC Specifications and Applications"*, DS00723

**AN884:** *"Driving Capacitive Loads With Op Amps"*, DS00884

**AN990:** *"Analog Sensor Conditioning Circuits – An Overview"*, DS00990

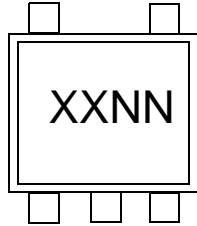
These application notes and others are listed in the design guide:

*"Signal Chain Design Guide"*, DS21825

## 6.0 PACKAGING INFORMATION

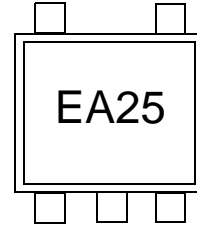
### 6.1 Package Marking Information

5-Lead SOT-23 (MCP6031)

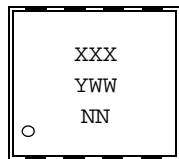


Device	E-Temp Code
MCP6031T-E/OT	EANN

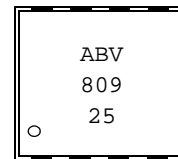
Example:



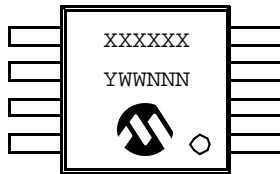
8-Lead 2x3 DFN (MCP6031 & MCP6033)



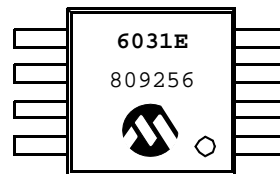
Example:



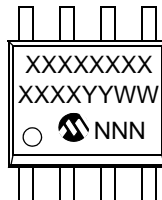
8-Lead MSOP



Example:



8-Lead SOIC (150 mil)



Example:



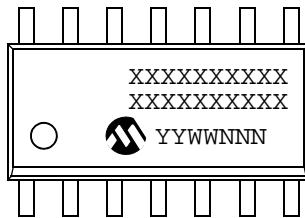
<b>Legend:</b>	XX...X	Customer-specific information
	Y	Year code (last digit of calendar year)
	YY	Year code (last 2 digits of calendar year)
	WW	Week code (week of January 1 is week '01')
	NNN	Alphanumeric traceability code
	(e3)	Pb-free JEDEC designator for Matte Tin (Sn)
	*	This package is Pb-free. The Pb-free JEDEC designator (e3) can be found on the outer packaging for this package.

**Note:** In the event the full Microchip part number cannot be marked on one line, it will be carried over to the next line, thus limiting the number of available characters for customer-specific information.

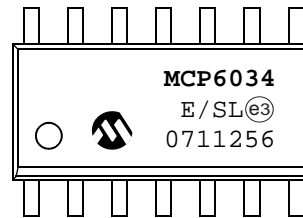
# MCP6031/2/3/4

## Package Marking Information (Continued)

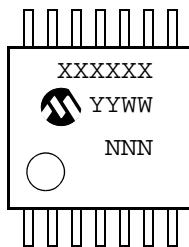
14-Lead SOIC (150 mil) (MCP6034)



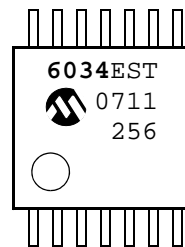
Example:



14-Lead TSSOP (MCP6034)



Example:

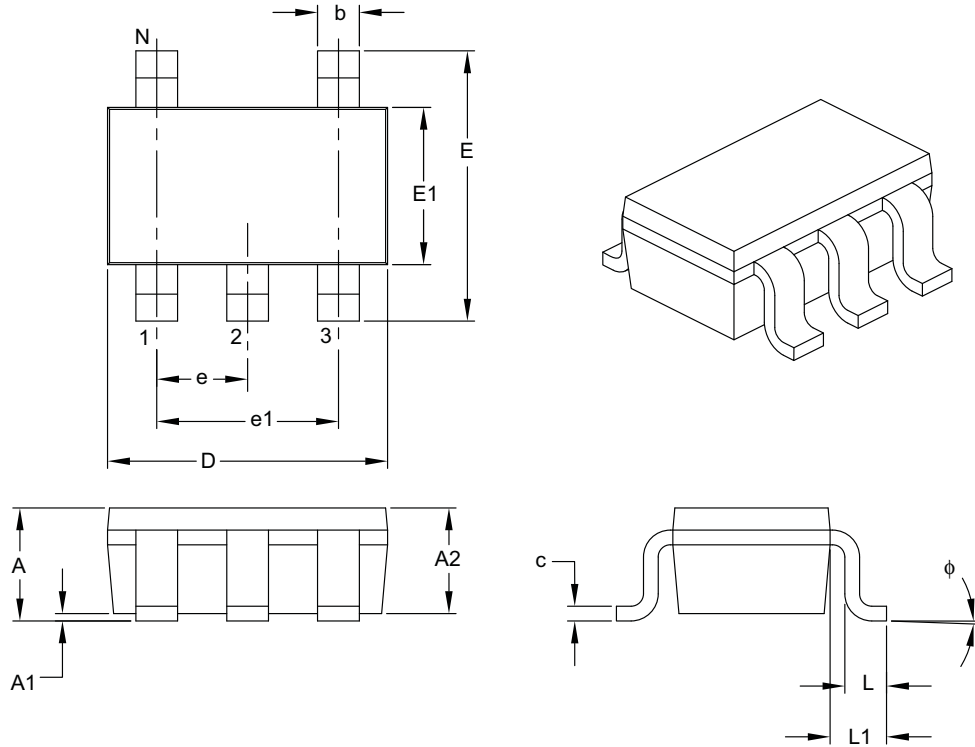


<b>Legend:</b>	XX...X	Customer-specific information
	Y	Year code (last digit of calendar year)
	YY	Year code (last 2 digits of calendar year)
	WW	Week code (week of January 1 is week '01')
	NNN	Alphanumeric traceability code
	Ⓜ	Pb-free JEDEC designator for Matte Tin (Sn)
	*	This package is Pb-free. The Pb-free JEDEC designator (Ⓜ) can be found on the outer packaging for this package.

**Note:** In the event the full Microchip part number cannot be marked on one line, it will be carried over to the next line, thus limiting the number of available characters for customer-specific information.

## 5-Lead Plastic Small Outline Transistor (OT) [SOT-23]

**Note:** For the most current package drawings, please see the Microchip Packaging Specification located at <http://www.microchip.com/packaging>



Dimension Limits	Units	MILLIMETERS		
		MIN	NOM	MAX
Number of Pins	N	5		
Lead Pitch	e	0.95 BSC		
Outside Lead Pitch	e1	1.90 BSC		
Overall Height	A	0.90	–	1.45
Molded Package Thickness	A2	0.89	–	1.30
Standoff	A1	0.00	–	0.15
Overall Width	E	2.20	–	3.20
Molded Package Width	E1	1.30	–	1.80
Overall Length	D	2.70	–	3.10
Foot Length	L	0.10	–	0.60
Footprint	L1	0.35	–	0.80
Foot Angle	$\phi$	0°	–	30°
Lead Thickness	c	0.08	–	0.26
Lead Width	b	0.20	–	0.51

**Notes:**

- Dimensions D and E1 do not include mold flash or protrusions. Mold flash or protrusions shall not exceed 0.127 mm per side.
- Dimensioning and tolerancing per ASME Y14.5M.

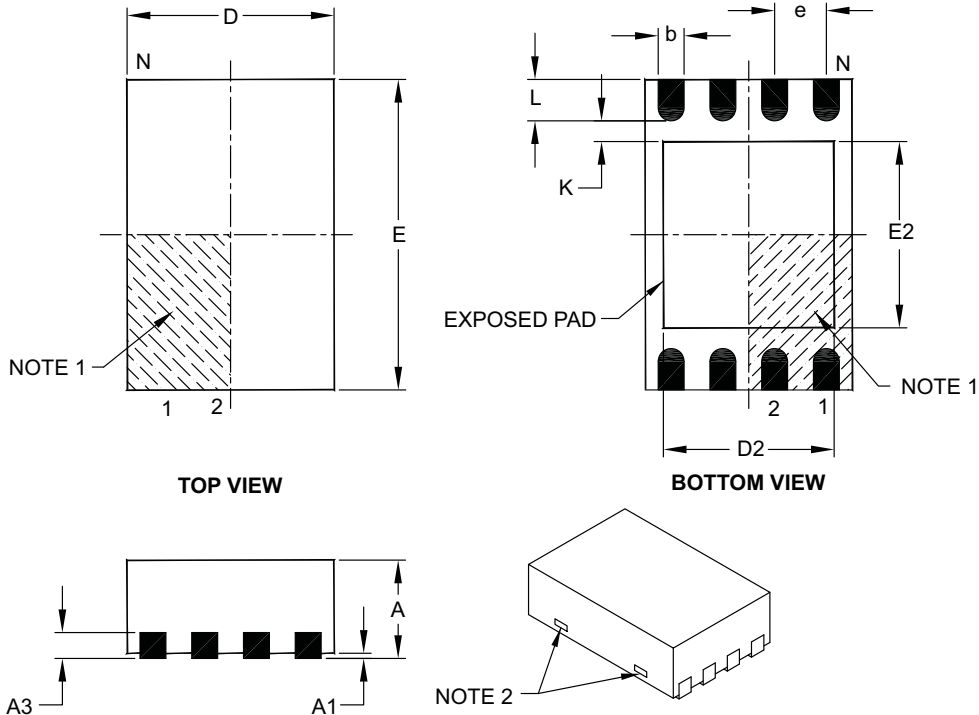
BSC: Basic Dimension. Theoretically exact value shown without tolerances.

Microchip Technology Drawing C04-091B

# MCP6031/2/3/4

## 8-Lead Plastic Dual Flat, No Lead Package (MC) – 2x3x0.9 mm Body [DFN]

**Note:** For the most current package drawings, please see the Microchip Packaging Specification located at <http://www.microchip.com/packaging>



Dimension Limits	Units	MILLIMETERS		
		MIN	NOM	MAX
Number of Pins	N	8		
Pitch	e	0.50 BSC		
Overall Height	A	0.80	0.90	1.00
Standoff	A1	0.00	0.02	0.05
Contact Thickness	A3	0.20 REF		
Overall Length	D	2.00 BSC		
Overall Width	E	3.00 BSC		
Exposed Pad Length	D2	1.30	–	1.55
Exposed Pad Width	E2	1.50	–	1.75
Contact Width	b	0.20	0.25	0.30
Contact Length	L	0.30	0.40	0.50
Contact-to-Exposed Pad	K	0.20	–	–

**Notes:**

- Pin 1 visual index feature may vary, but must be located within the hatched area.
- Package may have one or more exposed tie bars at ends.
- Package is saw singulated.
- Dimensioning and tolerancing per ASME Y14.5M.

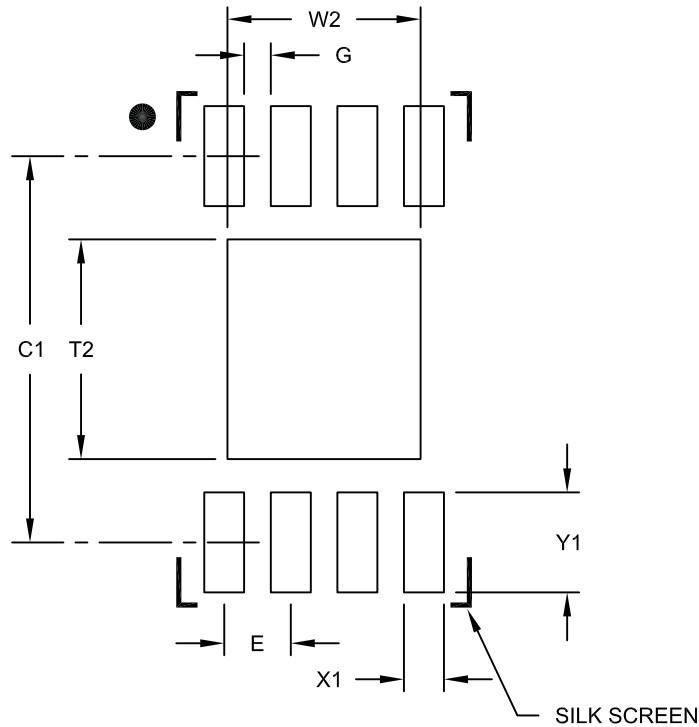
BSC: Basic Dimension. Theoretically exact value shown without tolerances.

REF: Reference Dimension, usually without tolerance, for information purposes only.

Microchip Technology Drawing C04-123C

## 8-Lead Plastic Dual Flat, No Lead Package (MC) – 2x3x0.9 mm Body [DFN]

**Note:** For the most current package drawings, please see the Microchip Packaging Specification located at <http://www.microchip.com/packaging>



RECOMMENDED LAND PATTERN

Dimension Limits	Units	MILLIMETERS		
		MIN	NOM	MAX
Contact Pitch	E	0.50 BSC		
Optional Center Pad Width	W2			1.45
Optional Center Pad Length	T2			1.75
Contact Pad Spacing	C1		2.90	
Contact Pad Width (X8)	X1			0.30
Contact Pad Length (X8)	Y1			0.75
Distance Between Pads	G	0.20		

Notes:

1. Dimensioning and tolerancing per ASME Y14.5M

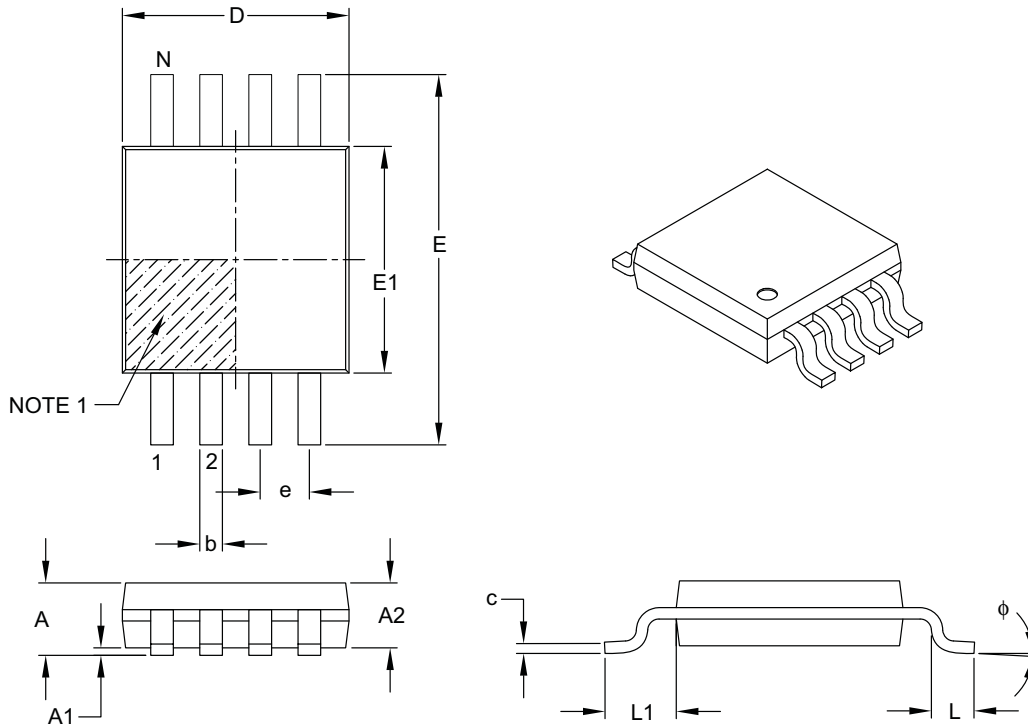
BSC: Basic Dimension. Theoretically exact value shown without tolerances.

Microchip Technology Drawing No. C04-2123A

# MCP6031/2/3/4

## 8-Lead Plastic Micro Small Outline Package (MS) [MSOP]

**Note:** For the most current package drawings, please see the Microchip Packaging Specification located at <http://www.microchip.com/packaging>



Dimension Limits	Units	MILLIMETERS		
		MIN	NOM	MAX
Number of Pins	N	8		
Pitch	e	0.65 BSC		
Overall Height	A	–	–	1.10
Molded Package Thickness	A2	0.75	0.85	0.95
Standoff	A1	0.00	–	0.15
Overall Width	E	4.90 BSC		
Molded Package Width	E1	3.00 BSC		
Overall Length	D	3.00 BSC		
Foot Length	L	0.40	0.60	0.80
Footprint	L1	0.95 REF		
Foot Angle	$\phi$	0°	–	8°
Lead Thickness	c	0.08	–	0.23
Lead Width	b	0.22	–	0.40

**Notes:**

- Pin 1 visual index feature may vary, but must be located within the hatched area.
- Dimensions D and E1 do not include mold flash or protrusions. Mold flash or protrusions shall not exceed 0.15 mm per side.
- Dimensioning and tolerancing per ASME Y14.5M.

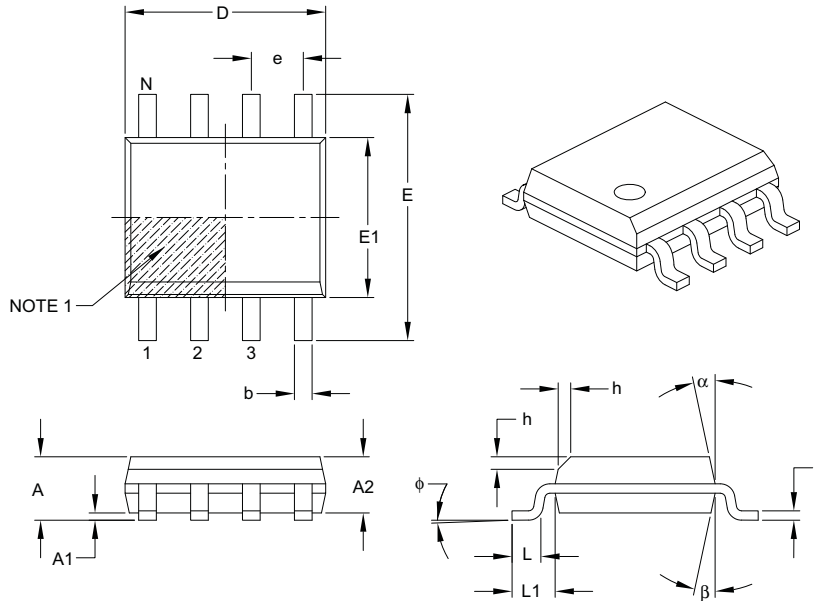
BSC: Basic Dimension. Theoretically exact value shown without tolerances.

REF: Reference Dimension, usually without tolerance, for information purposes only.

Microchip Technology Drawing C04-111B

## 8-Lead Plastic Small Outline (SN) – Narrow, 3.90 mm Body [SOIC]

**Note:** For the most current package drawings, please see the Microchip Packaging Specification located at <http://www.microchip.com/packaging>



Dimension Limits	Units	MILLIMETERS		
		MIN	NOM	MAX
Number of Pins	N	8		
Pitch	e	1.27 BSC		
Overall Height	A	–	–	1.75
Molded Package Thickness	A2	1.25	–	–
Standoff §	A1	0.10	–	0.25
Overall Width	E	6.00 BSC		
Molded Package Width	E1	3.90 BSC		
Overall Length	D	4.90 BSC		
Chamfer (optional)	h	0.25	–	0.50
Foot Length	L	0.40	–	1.27
Footprint	L1	1.04 REF		
Foot Angle	$\phi$	0°	–	8°
Lead Thickness	c	0.17	–	0.25
Lead Width	b	0.31	–	0.51
Mold Draft Angle Top	$\alpha$	5°	–	15°
Mold Draft Angle Bottom	$\beta$	5°	–	15°

**Notes:**

- Pin 1 visual index feature may vary, but must be located within the hatched area.
- § Significant Characteristic.
- Dimensions D and E1 do not include mold flash or protrusions. Mold flash or protrusions shall not exceed 0.15 mm per side.
- Dimensioning and tolerancing per ASME Y14.5M.

BSC: Basic Dimension. Theoretically exact value shown without tolerances.

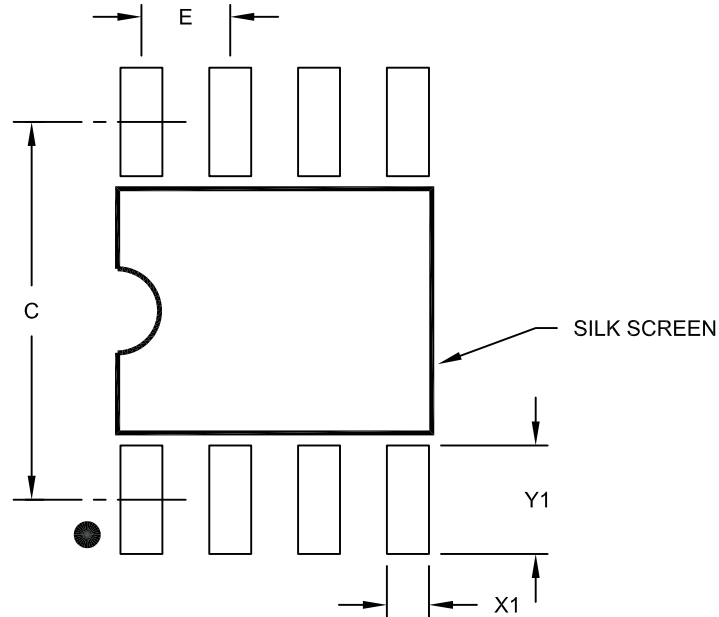
REF: Reference Dimension, usually without tolerance, for information purposes only.

Microchip Technology Drawing C04-057B

# MCP6031/2/3/4

## 8-Lead Plastic Small Outline (SN) – Narrow, 3.90 mm Body [SOIC]

**Note:** For the most current package drawings, please see the Microchip Packaging Specification located at <http://www.microchip.com/packaging>



RECOMMENDED LAND PATTERN

		Units	MILLIMETERS		
Dimension Limits			MIN	NOM	MAX
Contact Pitch	E		1.27 BSC		
Contact Pad Spacing	C			5.40	
Contact Pad Width (X8)	X1				0.60
Contact Pad Length (X8)	Y1				1.55

Notes:

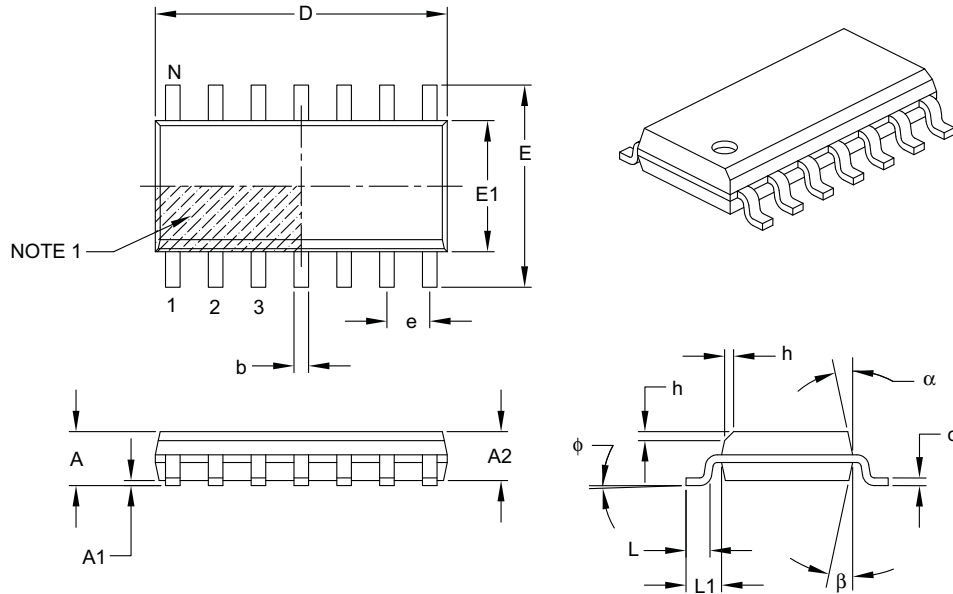
1. Dimensioning and tolerancing per ASME Y14.5M

BSC: Basic Dimension. Theoretically exact value shown without tolerances.

Microchip Technology Drawing No. C04-2057A

## 14-Lead Plastic Small Outline (SL) – Narrow, 3.90 mm Body [SOIC]

**Note:** For the most current package drawings, please see the Microchip Packaging Specification located at <http://www.microchip.com/packaging>



Dimension Limits	Units	MILLIMETERS		
		MIN	NOM	MAX
Number of Pins	N	14		
Pitch	e	1.27 BSC		
Overall Height	A	–	–	1.75
Molded Package Thickness	A2	1.25	–	–
Standoff §	A1	0.10	–	0.25
Overall Width	E	6.00 BSC		
Molded Package Width	E1	3.90 BSC		
Overall Length	D	8.65 BSC		
Chamfer (optional)	h	0.25	–	0.50
Foot Length	L	0.40	–	1.27
Footprint	L1	1.04 REF		
Foot Angle	$\phi$	0°	–	8°
Lead Thickness	c	0.17	–	0.25
Lead Width	b	0.31	–	0.51
Mold Draft Angle Top	$\alpha$	5°	–	15°
Mold Draft Angle Bottom	$\beta$	5°	–	15°

**Notes:**

- Pin 1 visual index feature may vary, but must be located within the hatched area.
- § Significant Characteristic.
- Dimensions D and E1 do not include mold flash or protrusions. Mold flash or protrusions shall not exceed 0.15 mm per side.
- Dimensioning and tolerancing per ASME Y14.5M.

BSC: Basic Dimension. Theoretically exact value shown without tolerances.

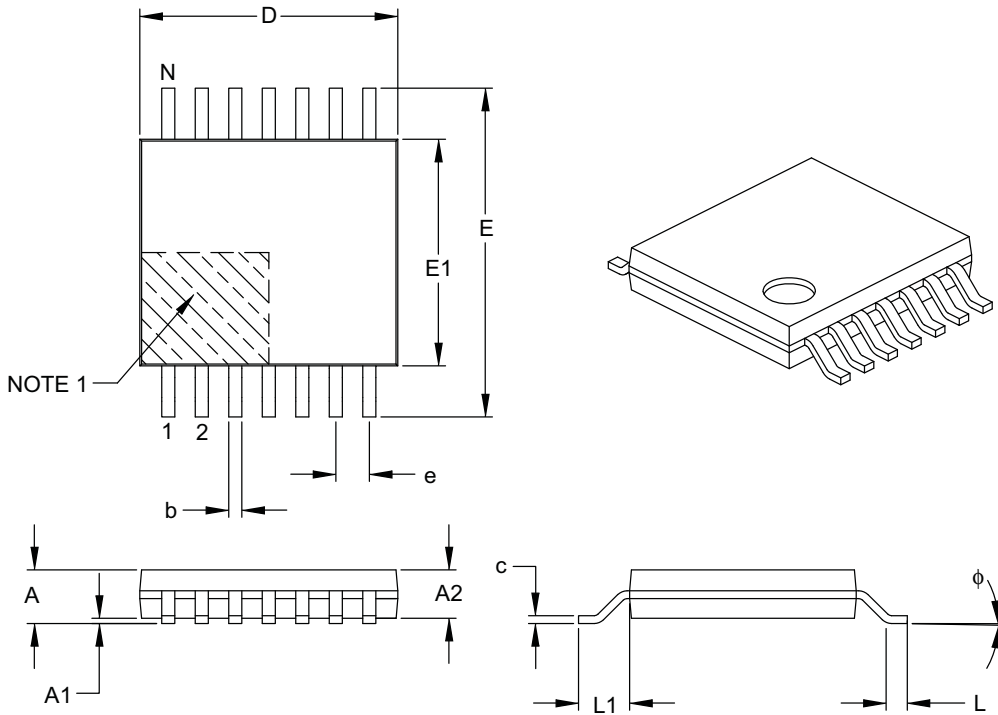
REF: Reference Dimension, usually without tolerance, for information purposes only.

Microchip Technology Drawing C04-065B

# MCP6031/2/3/4

## 14-Lead Plastic Thin Shrink Small Outline (ST) – 4.4 mm Body [TSSOP]

**Note:** For the most current package drawings, please see the Microchip Packaging Specification located at <http://www.microchip.com/packaging>



Dimension Limits	Units	MILLIMETERS		
		MIN	NOM	MAX
Number of Pins	N	14		
Pitch	e	0.65 BSC		
Overall Height	A	–	–	1.20
Molded Package Thickness	A2	0.80	1.00	1.05
Standoff	A1	0.05	–	0.15
Overall Width	E	6.40 BSC		
Molded Package Width	E1	4.30	4.40	4.50
Molded Package Length	D	4.90	5.00	5.10
Foot Length	L	0.45	0.60	0.75
Footprint	L1	1.00 REF		
Foot Angle	$\phi$	0°	–	8°
Lead Thickness	c	0.09	–	0.20
Lead Width	b	0.19	–	0.30

**Notes:**

- Pin 1 visual index feature may vary, but must be located within the hatched area.
- Dimensions D and E1 do not include mold flash or protrusions. Mold flash or protrusions shall not exceed 0.15 mm per side.
- Dimensioning and tolerancing per ASME Y14.5M.

BSC: Basic Dimension. Theoretically exact value shown without tolerances.

REF: Reference Dimension, usually without tolerance, for information purposes only.

Microchip Technology Drawing C04-087B

## APPENDIX A: REVISION HISTORY

### Revision B (March 2008)

The following is the list of modifications:

1. Added SOT-23-5 and 2x3 DFN packages.
2. Added test circuits.
3. Corrected  $V_{OS}$  temperature drift information.
4. Added Section 4.9.3.
5. Updated Package Marking Information.
6. Updated all package outline drawings and added package outline drawings for SOT-23-5 and 2x3 DFN packages.
7. Added Landing Pattern drawings for 2x3 DFN and 8-lead SOIC packages.
8. Updated information in Product Identification System for SOT-23-5 and 2x3 DFN packages.

### Revision A (March 2007)

- Original Release of this Document.

# MCP6031/2/3/4

---

NOTES:

## PRODUCT IDENTIFICATION SYSTEM

To order or obtain information, e.g., on pricing or delivery, refer to the factory or the listed sales office.

<u>PART NO.</u>	<u>X</u>	<u>/XX</u>	
Device	Temperature Range	Package	
Device:	MCP6031:	Single Op Amp	
	MCP6031T:	Single Op Amp (Tape and Reel)	
	MCP6032:	Dual Op Amp	
	MCP6032T:	Dual Op Amp (Tape and Reel)	
	MCP6033:	Single Op Amp with Chip Select	
	MCP6033T:	Single Op Amp with Chip Select (Tape and Reel)	
	MCP6034:	Quad Op Amp	
	MCP6034T:	Quad Op Amp (Tape and Reel)	
Temperature Range:	E	= -40°C to +125°C	
Package:	MC	= Plastic Dual Flat, No Lead, (2x3 DFN ) 8-lead **	
	MS	= Plastic MSOP, 8-lead	
	OT	= Plastic Small Outline Transistor, 5-lead *	
	SL	= Plastic SOIC (150 mil Body), 14-lead	
	SN	= Plastic SOIC, (150 mil Body), 8-lead	
	ST	= Plastic TSSOP (4.4mm Body), 14-lead	
	* This package is only available on the MCP6031 device.		
	** These packages are only available on the MCP6031 and MCP6033 devices.		
			<b>Examples:</b>
			a) MCP6031-E/SN: 8LD SOIC package.
			b) MCP6031T-E/SN: Tape and Reel, 8LD SOIC package.
			c) MCP6031-E/MS: 8LD MSOP package.
			d) MCP6031T-E/MS: Tape and Reel, 8LD MSOP package.
			e) MCP6031-E/MC: 8LD DFN package.
			f) MCP6031T-E/MC: Tape and Reel, 8LD DFN package.
			g) MCP6031T-E/OT: Tape and Reel, 5-LD SOT-23 package.
			a) MCP6032-E/SN: 8LD SOIC package.
			b) MCP6032T-E/SN: Tape and Reel, 8LD SOIC package.
			c) MCP6032-E/MS: 8LD MSOP package
			d) MCP6032T-E/MS: Tape and Reel 8LD MSOP package.
			a) MCP6033-E/SN: 8LD SOIC package.
			b) MCP6033T-E/SN: Tape and Reel, 8LD SOIC package.
			c) MCP6033-E/MS: 8LD MSOP package.
			d) MCP6033T-E/MS: Tape and Reel, 8LD MSOP package.
			e) MCP6033-E/MC: 8LD DFN package.
			f) MCP6033T-E/MC: Tape and Reel, 8LD DFN package.
			a) MCP6034-E/SL: 14LD SOIC package.
			b) MCP6034T-E/SL: Tape and Reel, 14LD SOIC package.
			c) MCP6034-E/ST: 14LD TSSOP package.
			d) MCP6034T-E/ST: Tape and Reel, 14LD TSSOP package.

# MCP6031/2/3/4

---

NOTES:

---

**Note the following details of the code protection feature on Microchip devices:**

- Microchip products meet the specification contained in their particular Microchip Data Sheet.
- Microchip believes that its family of products is one of the most secure families of its kind on the market today, when used in the intended manner and under normal conditions.
- There are dishonest and possibly illegal methods used to breach the code protection feature. All of these methods, to our knowledge, require using the Microchip products in a manner outside the operating specifications contained in Microchip's Data Sheets. Most likely, the person doing so is engaged in theft of intellectual property.
- Microchip is willing to work with the customer who is concerned about the integrity of their code.
- Neither Microchip nor any other semiconductor manufacturer can guarantee the security of their code. Code protection does not mean that we are guaranteeing the product as “unbreakable.”

Code protection is constantly evolving. We at Microchip are committed to continuously improving the code protection features of our products. Attempts to break Microchip's code protection feature may be a violation of the Digital Millennium Copyright Act. If such acts allow unauthorized access to your software or other copyrighted work, you may have a right to sue for relief under that Act.

---

Information contained in this publication regarding device applications and the like is provided only for your convenience and may be superseded by updates. It is your responsibility to ensure that your application meets with your specifications. MICROCHIP MAKES NO REPRESENTATIONS OR WARRANTIES OF ANY KIND WHETHER EXPRESS OR IMPLIED, WRITTEN OR ORAL, STATUTORY OR OTHERWISE, RELATED TO THE INFORMATION, INCLUDING BUT NOT LIMITED TO ITS CONDITION, QUALITY, PERFORMANCE, MERCHANTABILITY OR FITNESS FOR PURPOSE. Microchip disclaims all liability arising from this information and its use. Use of Microchip devices in life support and/or safety applications is entirely at the buyer's risk, and the buyer agrees to defend, indemnify and hold harmless Microchip from any and all damages, claims, suits, or expenses resulting from such use. No licenses are conveyed, implicitly or otherwise, under any Microchip intellectual property rights.

**Trademarks**

The Microchip name and logo, the Microchip logo, Accuron, dsPIC, KEELOQ, KEELOQ logo, MPLAB, PIC, PICmicro, PICSTART, PRO MATE, rPIC and SmartShunt are registered trademarks of Microchip Technology Incorporated in the U.S.A. and other countries.


FilterLab, Linear Active Thermistor, MXDEV, MXLAB, SEEVAL, SmartSensor and The Embedded Control Solutions Company are registered trademarks of Microchip Technology Incorporated in the U.S.A.

Analog-for-the-Digital Age, Application Maestro, CodeGuard, dsPICDEM, dsPICDEM.net, dsPICworks, dsSPEAK, ECAN, ECONOMONITOR, FanSense, In-Circuit Serial Programming, ICSP, ICEPIC, Mindi, MiWi, MPASM, MPLAB Certified logo, MPLIB, MPLINK, mTouch, PICkit, PICDEM, PICDEM.net, PICtail, PIC<sup>32</sup> logo, PowerCal, PowerInfo, PowerMate, PowerTool, REAL ICE, rLAB, Select Mode, Total Endurance, UNI/O, WiperLock and ZENA are trademarks of Microchip Technology Incorporated in the U.S.A. and other countries.

SQTP is a service mark of Microchip Technology Incorporated in the U.S.A.

All other trademarks mentioned herein are property of their respective companies.

© 2008, Microchip Technology Incorporated, Printed in the U.S.A., All Rights Reserved.

 Printed on recycled paper.

**QUALITY MANAGEMENT SYSTEM**  
**CERTIFIED BY DNV**  
**== ISO/TS 16949:2002 ==**

*Microchip received ISO/TS-16949:2002 certification for its worldwide headquarters, design and wafer fabrication facilities in Chandler and Tempe, Arizona; Gresham, Oregon and design centers in California and India. The Company's quality system processes and procedures are for its PIC® MCUs and dsPIC® DSCs, KEELOQ® code hopping devices, Serial EEPROMs, microperipherals, nonvolatile memory and analog products. In addition, Microchip's quality system for the design and manufacture of development systems is ISO 9001:2000 certified.*



## WORLDWIDE SALES AND SERVICE

### AMERICAS

**Corporate Office**  
2355 West Chandler Blvd.  
Chandler, AZ 85224-6199  
Tel: 480-792-7200  
Fax: 480-792-7277  
Technical Support:  
<http://support.microchip.com>  
Web Address:  
[www.microchip.com](http://www.microchip.com)

**Atlanta**  
Duluth, GA  
Tel: 678-957-9614  
Fax: 678-957-1455

**Boston**  
Westborough, MA  
Tel: 774-760-0087  
Fax: 774-760-0088

**Chicago**  
Itasca, IL  
Tel: 630-285-0071  
Fax: 630-285-0075

**Dallas**  
Addison, TX  
Tel: 972-818-7423  
Fax: 972-818-2924

**Detroit**  
Farmington Hills, MI  
Tel: 248-538-2250  
Fax: 248-538-2260

**Kokomo**  
Kokomo, IN  
Tel: 765-864-8360  
Fax: 765-864-8387

**Los Angeles**  
Mission Viejo, CA  
Tel: 949-462-9523  
Fax: 949-462-9608

**Santa Clara**  
Santa Clara, CA  
Tel: 408-961-6444  
Fax: 408-961-6445

**Toronto**  
Mississauga, Ontario,  
Canada  
Tel: 905-673-0699  
Fax: 905-673-6509

### ASIA/PACIFIC

**Asia Pacific Office**  
Suites 3707-14, 37th Floor  
Tower 6, The Gateway  
Harbour City, Kowloon  
Hong Kong  
Tel: 852-2401-1200  
Fax: 852-2401-3431

**Australia - Sydney**  
Tel: 61-2-9868-6733  
Fax: 61-2-9868-6755

**China - Beijing**  
Tel: 86-10-8528-2100  
Fax: 86-10-8528-2104

**China - Chengdu**  
Tel: 86-28-8665-5511  
Fax: 86-28-8665-7889

**China - Hong Kong SAR**  
Tel: 852-2401-1200  
Fax: 852-2401-3431

**China - Nanjing**  
Tel: 86-25-8473-2460  
Fax: 86-25-8473-2470

**China - Qingdao**  
Tel: 86-532-8502-7355  
Fax: 86-532-8502-7205

**China - Shanghai**  
Tel: 86-21-5407-5533  
Fax: 86-21-5407-5066

**China - Shenyang**  
Tel: 86-24-2334-2829  
Fax: 86-24-2334-2393

**China - Shenzhen**  
Tel: 86-755-8203-2660  
Fax: 86-755-8203-1760

**China - Wuhan**  
Tel: 86-27-5980-5300  
Fax: 86-27-5980-5118

**China - Xiamen**  
Tel: 86-592-2388138  
Fax: 86-592-2388130

**China - Xian**  
Tel: 86-29-8833-7252  
Fax: 86-29-8833-7256

**China - Zhuhai**  
Tel: 86-756-3210040  
Fax: 86-756-3210049

### ASIA/PACIFIC

**India - Bangalore**  
Tel: 91-80-4182-8400  
Fax: 91-80-4182-8422

**India - New Delhi**  
Tel: 91-11-4160-8631  
Fax: 91-11-4160-8632

**India - Pune**  
Tel: 91-20-2566-1512  
Fax: 91-20-2566-1513

**Japan - Yokohama**  
Tel: 81-45-471- 6166  
Fax: 81-45-471-6122

**Korea - Daegu**  
Tel: 82-53-744-4301  
Fax: 82-53-744-4302

**Korea - Seoul**  
Tel: 82-2-554-7200  
Fax: 82-2-558-5932 or  
82-2-558-5934

**Malaysia - Kuala Lumpur**  
Tel: 60-3-6201-9857  
Fax: 60-3-6201-9859

**Malaysia - Penang**  
Tel: 60-4-227-8870  
Fax: 60-4-227-4068

**Philippines - Manila**  
Tel: 63-2-634-9065  
Fax: 63-2-634-9069

**Singapore**  
Tel: 65-6334-8870  
Fax: 65-6334-8850

**Taiwan - Hsin Chu**  
Tel: 886-3-572-9526  
Fax: 886-3-572-6459

**Taiwan - Kaohsiung**  
Tel: 886-7-536-4818  
Fax: 886-7-536-4803

**Taiwan - Taipei**  
Tel: 886-2-2500-6610  
Fax: 886-2-2508-0102

**Thailand - Bangkok**  
Tel: 66-2-694-1351  
Fax: 66-2-694-1350

### EUROPE

**Austria - Wels**  
Tel: 43-7242-2244-39  
Fax: 43-7242-2244-393

**Denmark - Copenhagen**  
Tel: 45-4450-2828  
Fax: 45-4485-2829

**France - Paris**  
Tel: 33-1-69-53-63-20  
Fax: 33-1-69-30-90-79

**Germany - Munich**  
Tel: 49-89-627-144-0  
Fax: 49-89-627-144-44

**Italy - Milan**  
Tel: 39-0331-742611  
Fax: 39-0331-466781

**Netherlands - Drunen**  
Tel: 31-416-690399  
Fax: 31-416-690340

**Spain - Madrid**  
Tel: 34-91-708-08-90  
Fax: 34-91-708-08-91

**UK - Wokingham**  
Tel: 44-118-921-5869  
Fax: 44-118-921-5820

## Looking for pricing, stock, or lifecycle information?

Click below to explore more details on WIN SOURCE:

- ⊖ [View MCP6032T-E/SN on WIN SOURCE](#)
- ⊖ [Microchip Technology](#) Information

## Optimize Your Supply Chain with WIN SOURCE Solutions

- ✓ Global Sourcing Solution
- ✓ Obsolete Management
- ✓ Cost Control Management
- ✓ Shortage Management
- ✓ Alternative Solution
- ✓ Excess Inventory Management