



**THE DATASHEET OF  
SN74LS624DR**



# SN54LS624 THRU SN54LS629, SN74LS624 THRU SN74LS629 VOLTAGE-CONTROLLED OSCILLATORS

SDLS186 – JANUARY 1980 – REVISED MARCH 1988

- **Separate Supply Voltage Pins for Isolation of Frequency Control Inputs and Oscillators from Output Circuitry**
- **Highly Stable Operation over Specified Temperature and/or Supply Voltage Ranges**

DEVICE TYPE	SIMILAR TO	NUMBER VCO's	COMP'L Z OUT	ENABLE	RANGE INPUT	R <sub>ext</sub>
'LS624	'LS324	single	yes	yes	yes	no
'LS625	'LS325	dual	yes	no	no	no
'LS626	'LS326	dual	yes	yes	no	no
'LS627	'LS327	dual	no	no	no	no
'LS628	'LS324	single	yes	yes	yes	yes
'LS629	'LS124	dual	no	yes	yes	no

## description

These voltage-controlled oscillators (VCOs) are improved versions of the original VCO family: SN54LS124, SN54LS324 thru SN54LS327, SN74LS124, and SN74LS324 thru SN74LS327. These new devices feature improved voltage-to-frequency linearity, range, and compensation. With the exception of the 'LS624 and 'LS628, all of these devices feature two independent VCOs in a single monolithic chip. The 'LS624, 'LS625, 'LS626, and 'LS628 have complementary Z outputs. The output frequency for each VCO is established by a single external component (either a capacitor or crystal) in combination with voltage-sensitive inputs used for frequency control and frequency range. Each device has a voltage-sensitive input for frequency control; however, the 'LS624, 'LS628, and 'LS629 devices also have one for frequency range. (See Figures 1 thru 6).

The 'LS628 offers more precise temperature compensation than its 'LS624 counterpart. The 'LS624 features a 600 ohm internal timing resistor. The 'LS628 requires a timing resistor to be connected externally across R<sub>ext</sub> pins. Temperature compensation will be improved due to the temperature coefficient of the external resistor.

Figure 3 and Figure 6 contain the necessary information to choose the proper capacitor value to obtain the desired operating frequency.

A single 5-volt supply can be used: however, one set of supply voltage and ground pins (V<sub>CC</sub> and GND) is provided for the enable, synchronization-gating, and output sections, and a separate set (OSC V<sub>CC</sub> and OSC GND) is provided for the oscillator and associated frequency-control circuits so that effective isolation can be accomplished in the system. For operation of frequencies greater than 10 MHz, it is recommended that two independent supplies be used. Disabling either VCO of the 'LS625 and 'LS626 and 'LS627 can be achieved by removing the appropriate OSC V<sub>CC</sub>. An enable input is provided on the 'LS624, 'LS626, 'LS628, and 'LS629. When the enable input is low, the output is enabled: when the enable input is high, the internal oscillator is disabled, Y is high, and Z is low. Caution! Crosstalk may occur in the dual devices ('LS625, 'LS626, 'LS627 and 'LS629) when both VCOs are operated simultaneously. To minimize crosstalk, either of the following are recommended: (A) If frequencies are widely separated, use a 10-μh inductor between V<sub>CC</sub> pins. (B) If frequencies are closely spaced, use two separate V<sub>CC</sub> supplies or place two series diodes between the V<sub>CC</sub> pins.

The pulse-synchronization-gating section ensures that the first output pulse is neither clipped nor extended. The duty cycle of the square-wave output is fixed at approximately 50 percent.

The SN54LS624 thru SN54LS629 are characterized for operation over the full military temperature range of -55°C to 125°C. The SN74LS624 thru SN74LS629 are characterized for operation from 0°C to 70°C.

# SN54LS624 THRU SN54LS629, SN74LS624 THRU SN74LS629 VOLTAGE-CONTROLLED OSCILLATORS

SDLS186 – JANUARY 1980 – REVISED MARCH 1988

**SN54LS624 . . . J OR W PACKAGE  
SN74LS624 . . . D OR N PACKAGE  
(TOP VIEW)**

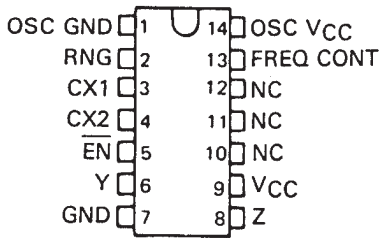

**SN54LS625 . . . J OR W PACKAGE  
SN74LS625 . . . D OR N PACKAGE  
(TOP VIEW)**

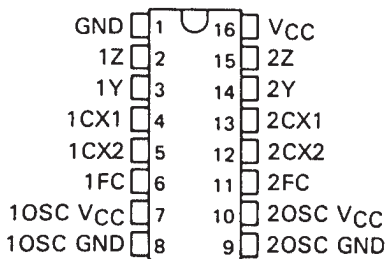

**SN54LS626 . . . J OR W PACKAGE  
SN74LS626 . . . D OR N PACKAGE  
(TOP VIEW)**

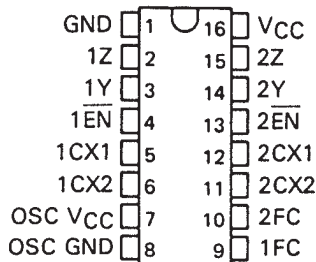

NC – No internal connection

**SN54LS624 . . . FK PACKAGE  
(TOP VIEW)**

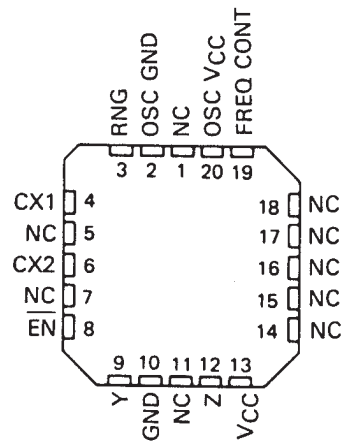

**SN54LS625 . . . FK PACKAGE  
(TOP VIEW)**

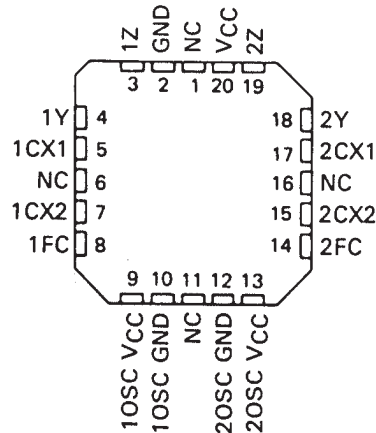

**SN54LS626 . . . FK PACKAGE  
(TOP VIEW)**

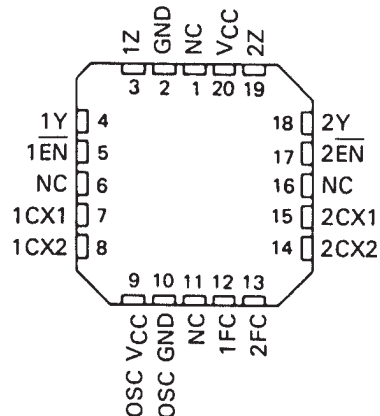

# SN54LS624 THRU SN54LS629, SN74LS624 THRU SN74LS629 VOLTAGE-CONTROLLED OSCILLATORS

SDLS186 - JANUARY 1980 - REVISED MARCH 1988

**SN54LS627 . . . J OR W PACKAGE  
SN74LS627 . . . D OR N PACKAGE  
(TOP VIEW)**

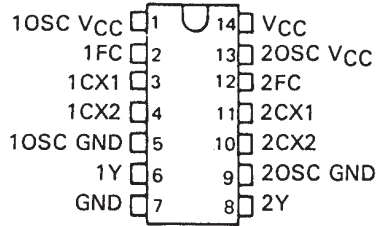

**SN54LS628 . . . J OR W PACKAGE  
SN74LS628 . . . D OR N PACKAGE  
(TOP VIEW)**

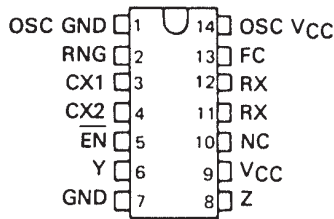

**SN54LS629 . . . J OR W PACKAGE  
SN74LS629 . . . D OR N PACKAGE  
(TOP VIEW)**

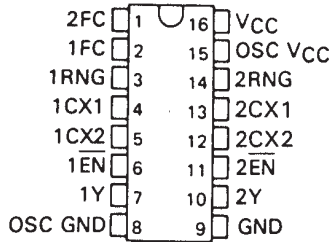

NC-No internal connection

**SN54LS627 . . . FK PACKAGE  
(TOP VIEW)**

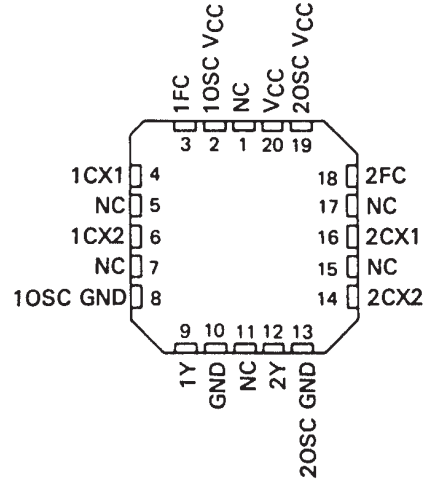

**SN54LS628 . . . FK PACKAGE  
(TOP VIEW)**

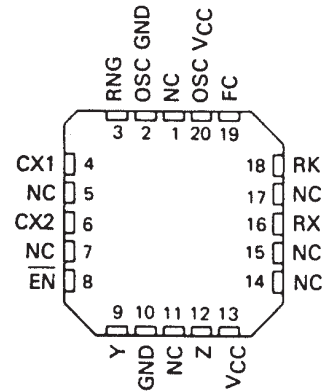

**SN54LS629 . . . FK PACKAGE  
(TOP VIEW)**

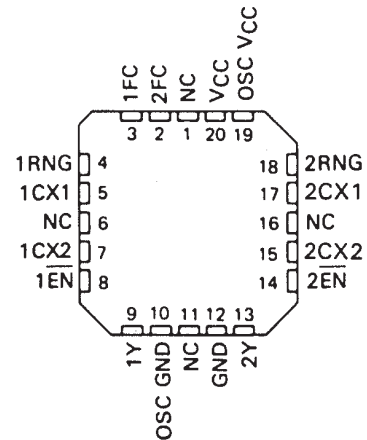

# SN54LS624 THRU SN54LS629, SN74LS624 THRU SN74LS629 VOLTAGE-CONTROLLED OSCILLATORS

SDLS186 – JANUARY 1980 – REVISED MARCH 1988

## logic diagram (positive logic)

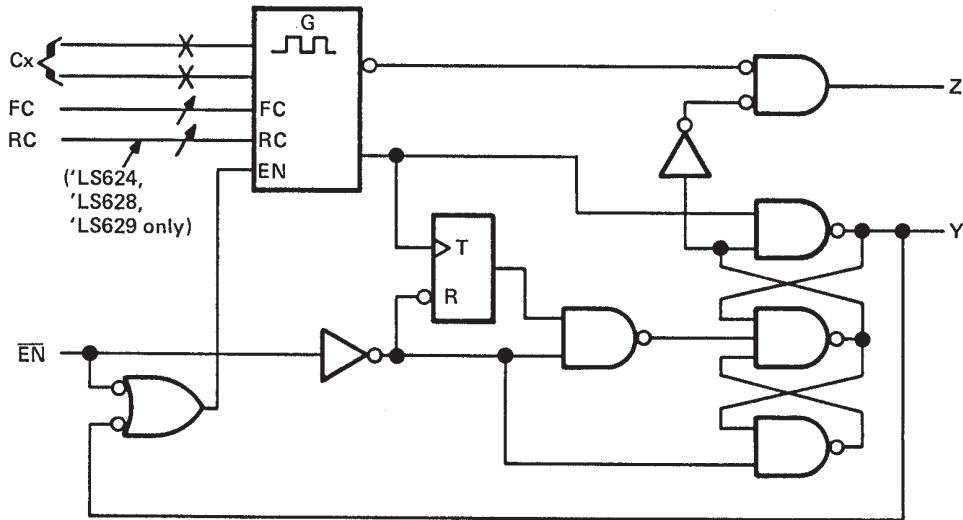

## logic symbols†

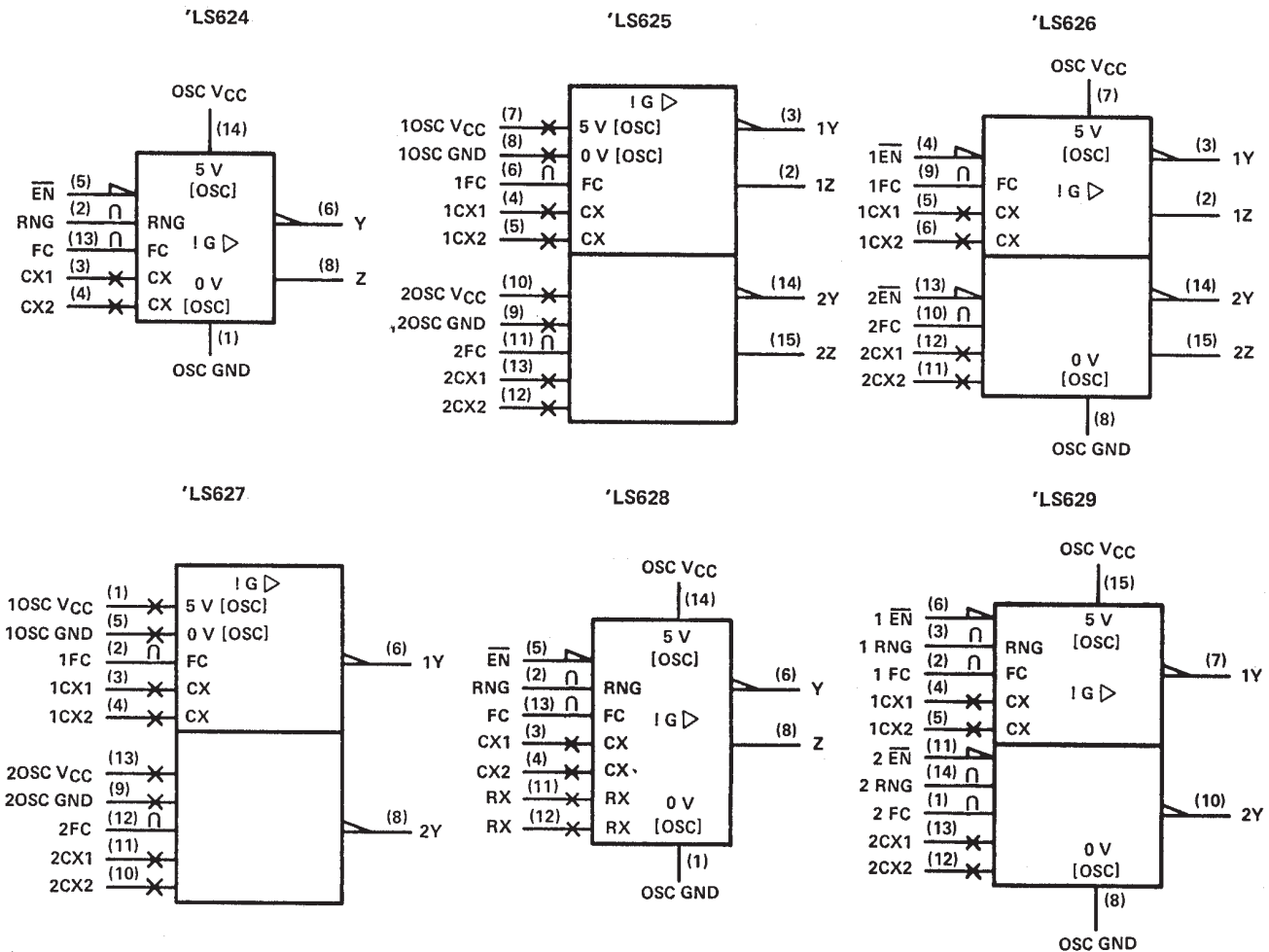

†These symbols are in accordance with ANSI/IEEE Std. 91-1984 and IEC Publication 617-12. Pin numbers shown are for D, J, N, and W packages.



# SN54LS624 THRU SN54LS629, SN74LS624 THRU SN74LS629 VOLTAGE-CONTROLLED OSCILLATORS

SDLS186 – JANUARY 1980 – REVISED MARCH 1988

## recommended operating conditions

	SN54LS'			SN74LS'			UNIT
	MIN	NOM	MAX	MIN	NOM	MAX	
Supply voltage, $V_{CC}$	4.5	5	5.5	4.75	5	5.25	V
Input voltage at frequency control or range input, $V_{I(freq)}$ or $V_{I(rng)}$	0		5	0		5	V
High-level output current, $I_{OH}$			-1.2			-1.2	mA
Low-level output current, $I_{OL}$			12			24	mA
Output frequency, $f_o$	1			1			Hz
			20			20	MHz
Operating free-air temperature, $T_A$	-55		125	0		70	°C

## electrical characteristics over recommended operating free-air temperature range (unless otherwise noted)

PARAMETER		TEST CONDITIONS†	SN54LS'			SN74LS'			UNIT	
			MIN	TYP‡	MAX	MIN	TYP‡	MAX		
$V_{IH}$	High-level input voltage at enable#		2			2			V	
$V_{IL}$	Low-level input voltage at enable#				0.7			0.8	V	
$V_{IK}$	Input clamp voltage at enable#	$V_{CC} = \text{MIN}, I_I = -18 \text{ mA}$			-1.5			-1.5	V	
$V_{OH}$	High-level output voltage	$V_{CC} = \text{MIN}, \overline{EN}$ at $V_{IL}$ max, $I_{OH} = -1.2 \text{ mA}$ , See Note 3	2.5	3.4		2.7	3.4		V	
$V_{OL}$	Low-level output voltage	$V_{CC} = \text{MIN}, \overline{EN}$ at $V_{IL}$ max, See Note 3	$I_{OL} = 12 \text{ mA}$		0.25	0.4	$I_{OL} = 24 \text{ mA}$		V	
							0.35	0.5		
$I_I$	Input current	Freq control or range‡	$V_{CC} = \text{MAX}$	$V_I = 5 \text{ V}$		50	250	$V_I = 5 \text{ V}$		$\mu\text{A}$
				$V_I = 1 \text{ V}$		10	50	$V_I = 1 \text{ V}$		
$I_I$	Input current at maximum input voltage	Enable#	$V_{CC} = \text{MAX}, V_I = 7 \text{ V}$			0.2			0.2	mA
$I_{IH}$	High-level input current	Enable#	$V_{CC} = \text{MAX}, V_I = 2.7 \text{ V}$			40			40	$\mu\text{A}$
$I_{IL}$	Low-level input current	Enable#	$V_{CC} = \text{MAX}, V_I = 0.4 \text{ V}$			-0.8			-0.8	mA
$I_{OS}$	Short-circuit output current§	$V_{CC} = \text{MAX}$	-40		-225	-40		-225	mA	
$I_{CC}$	Supply current, total into $V_{CC}$ and OSC $V_{CC}$ pins	$V_{CC} = \text{MAX}, \text{Enable}^\# = 4.5 \text{ V}$ See Note 4	'LS624		20	35	'LS624		mA	
			'LS625		35	55	'LS625			
			'LS626		35	55	'LS626			
			'LS627		35	55	'LS627			
			'LS628		20	35	'LS628			
			'LS629		35	55	'LS629			

†For conditions shown as MIN or MAX, use the appropriate value specified under recommended operating conditions.

‡All typical values are at  $V_{CC} = 5 \text{ V}, T_A = 25^\circ\text{C}$ .

§Not more than one output should be shorted at a time and duration of the short-circuit should not exceed one second.

¶The range input is provided only on the 'LS624, 'LS628, and 'LS629.

#The enable input is provided only on the 'LS624, 'LS626, 'LS628, and 'LS629.

NOTES: 3.  $V_{OH}$  for Y outputs and  $V_{OL}$  for Z outputs are measured while enable inputs are at  $V_{IL}$  MAX, with individual 1-k $\Omega$  resistors connected from CX1 to  $V_{CC}$  and from CX2 to ground. The resistor connections are reversed for testing  $V_{OH}$  for Z outputs and  $V_{OL}$  for Y inputs.

4. For 'LS624, 'LS626, 'LS628, and 'LS629,  $I_{CC}$  is measured with the outputs disabled and open. For 'LS625 and 'LS627,  $I_{CC}$  is measured with one OSC  $V_{CC} = \text{MAX}$ , and with the other OSC  $V_{CC}$  and outputs open.



SN54LS624 THRU SN54LS629,  
SN74LS624 THRU SN74LS629  
VOLTAGE-CONTROLLED OSCILLATORS

SDLS186 – JANUARY 1980 – REVISED MARCH 1988

switching characteristics,  $V_{CC} = 5\text{ V}$  (unless otherwise noted),  $R_L = 667\ \Omega$ ,  $C_L = 45\text{ pF}$ ,  $T_A = 25^\circ\text{C}$

PARAMETER	TEST CONDITIONS		'LS624, 'LS628, 'LS629			'LS625, 'LS626, 'LS627			UNIT
			MIN	TYP	MAX	MIN	TYP	MAX	
$f_O$ Output frequency	$C_{ext} = 50\text{ pF}$	$V_{I(freq)} = 5\text{ V}, V_{I(rng)} = 0\text{ V}$	15	20	25				MHz
		$V_{I(freq)} = 1\text{ V}, V_{I(rng)} = 5\text{ V}$	1.1	1.6	2.1				
		$V_{I(freq)} = 5\text{ V}$				7	9.5	12	
		$V_{I(freq)} = 0\text{ V}$				0.9	1.2	1.5	

TYPICAL CHARACTERISTICS

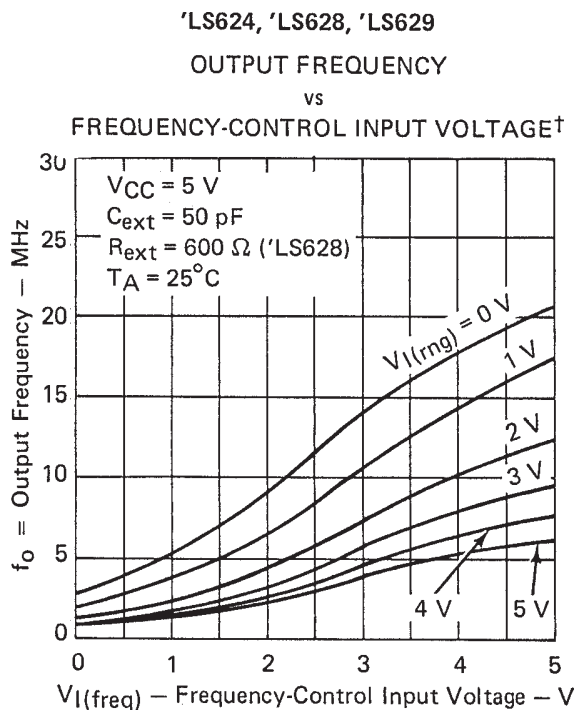

FIGURE 1

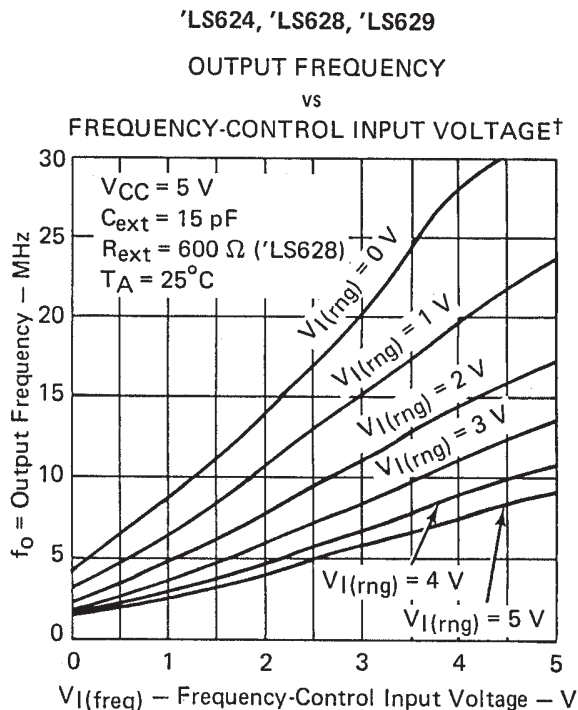

FIGURE 2

† Due to the effects of stray capacitance the output frequency may be unstable when the frequency control voltage is less than 1 volt.

**SN54LS624 THRU SN54LS629,  
SN74LS624 THRU SN74LS629  
VOLTAGE-CONTROLLED OSCILLATORS**

SDLS186 – JANUARY 1980 – REVISED MARCH 1988

**TYPICAL CHARACTERISTICS**

'LS624, 'LS628, 'LS629

OUTPUT FREQUENCY

vs

EXTERNAL CAPACITANCE

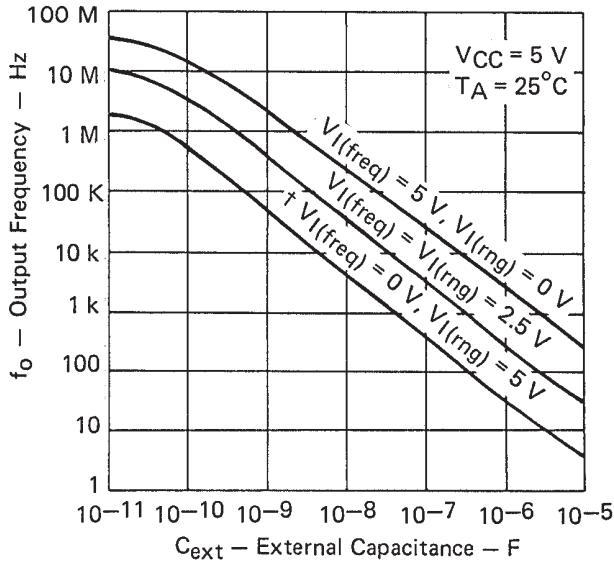

FIGURE 3

'LS625, 'LS626, 'LS627

OUTPUT FREQUENCY

vs

FREQUENCY-CONTROL INPUT VOLTAGE †

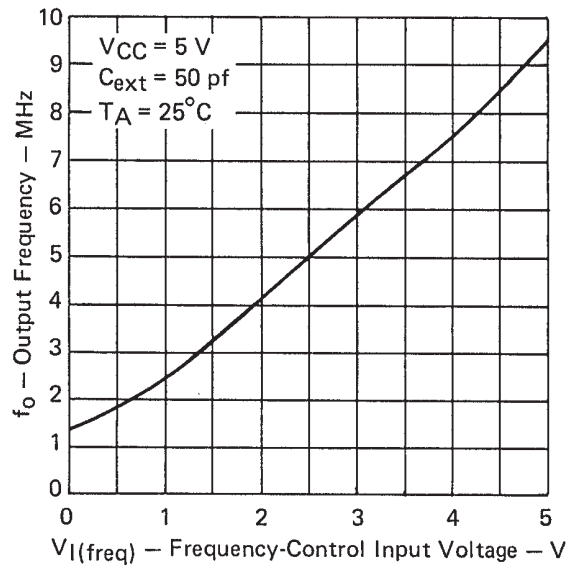

FIGURE 4

'LS625, 'LS626, 'LS627

OUTPUT FREQUENCY

vs

FREQUENCY-CONTROL INPUT VOLTAGE

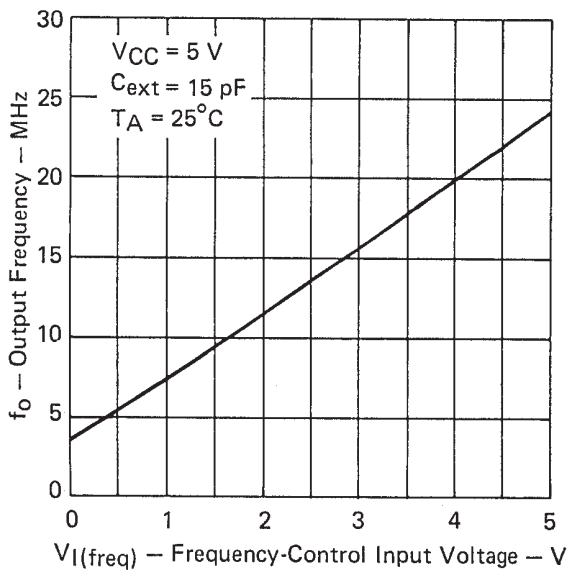

FIGURE 5

'LS625, 'LS626, 'LS627

OUTPUT FREQUENCY

vs

EXTERNAL CAPACITANCE

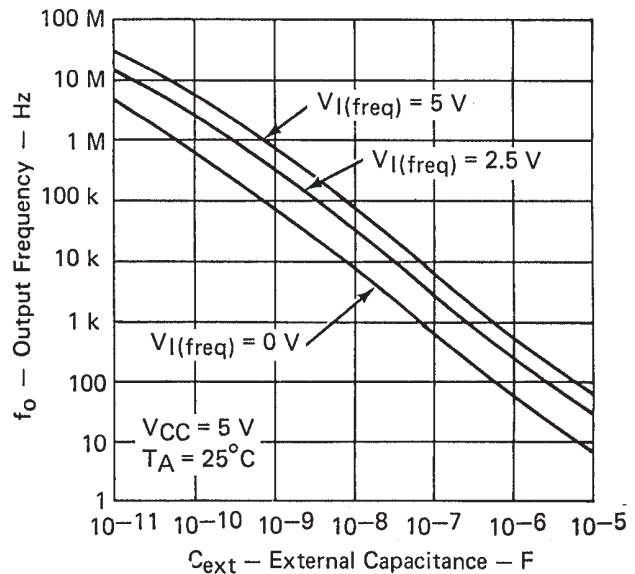

FIGURE 6

† Due to the effects of stray capacitance the output frequency may be unstable when the frequency control voltage is less than 1 volt.

TYPICAL CHARACTERISTICS

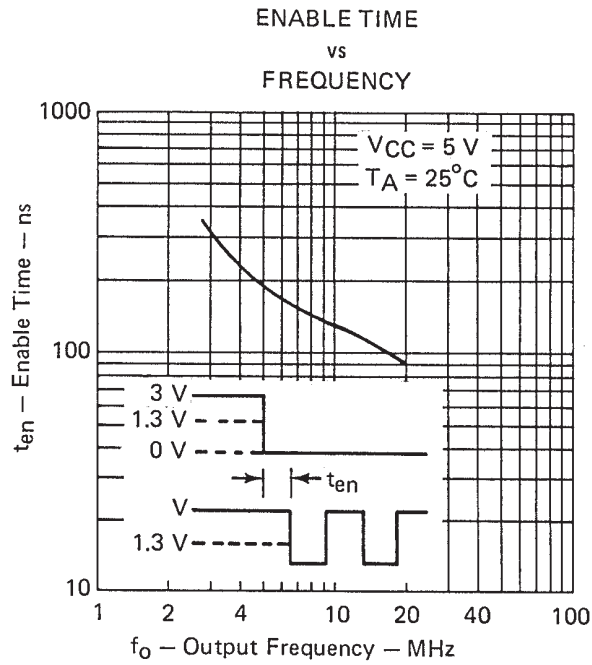
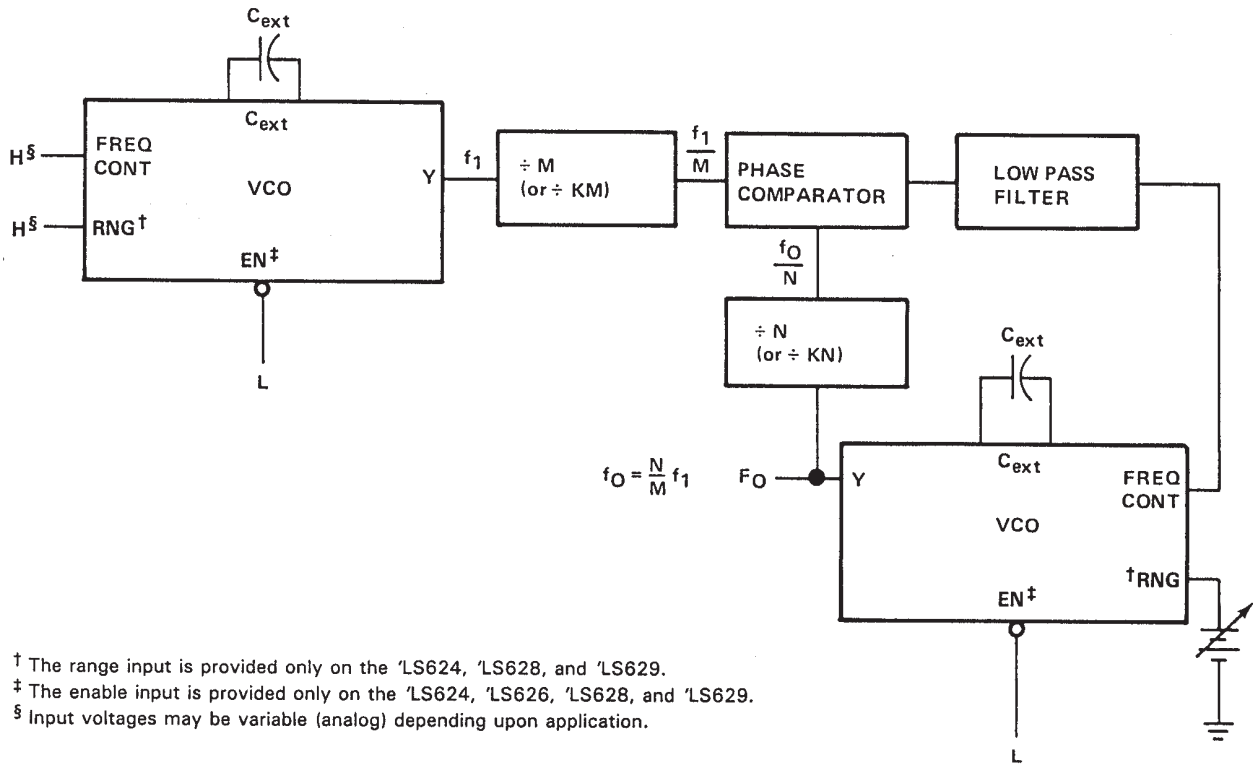

FIGURE 7

TYPICAL APPLICATIONS DATA



† The range input is provided only on the 'LS624, 'LS628, and 'LS629.  
 ‡ The enable input is provided only on the 'LS624, 'LS626, 'LS628, and 'LS629.  
 § Input voltages may be variable (analog) depending upon application.

FIGURE A—PHASE-LOCKED LOOP.

## TAPE AND REEL INFORMATION



### QUADRANT ASSIGNMENTS FOR PIN 1 ORIENTATION IN TAPE



\*All dimensions are nominal

Device	Package Type	Package Drawing	Pins	SPQ	Reel Diameter (mm)	Reel Width W1 (mm)	A0 (mm)	B0 (mm)	K0 (mm)	P1 (mm)	W (mm)	Pin1 Quadrant
SN74LS624DR	SOIC	D	14	2500	330.0	16.4	6.5	9.0	2.1	8.0	16.0	Q1
SN74LS624NSR	SO	NS	14	2000	330.0	16.4	8.2	10.5	2.5	12.0	16.0	Q1
SN74LS628DR	SOIC	D	14	2500	330.0	16.4	6.5	9.0	2.1	8.0	16.0	Q1

**TAPE AND REEL BOX DIMENSIONS**

\*All dimensions are nominal

Device	Package Type	Package Drawing	Pins	SPQ	Length (mm)	Width (mm)	Height (mm)
SN74LS624DR	SOIC	D	14	2500	367.0	367.0	38.0
SN74LS624NSR	SO	NS	14	2000	367.0	367.0	38.0
SN74LS628DR	SOIC	D	14	2500	367.0	367.0	38.0

## IMPORTANT NOTICE

Texas Instruments Incorporated and its subsidiaries (TI) reserve the right to make corrections, enhancements, improvements and other changes to its semiconductor products and services per JESD46, latest issue, and to discontinue any product or service per JESD48, latest issue. Buyers should obtain the latest relevant information before placing orders and should verify that such information is current and complete. All semiconductor products (also referred to herein as "components") are sold subject to TI's terms and conditions of sale supplied at the time of order acknowledgment.

TI warrants performance of its components to the specifications applicable at the time of sale, in accordance with the warranty in TI's terms and conditions of sale of semiconductor products. Testing and other quality control techniques are used to the extent TI deems necessary to support this warranty. Except where mandated by applicable law, testing of all parameters of each component is not necessarily performed.

TI assumes no liability for applications assistance or the design of Buyers' products. Buyers are responsible for their products and applications using TI components. To minimize the risks associated with Buyers' products and applications, Buyers should provide adequate design and operating safeguards.

TI does not warrant or represent that any license, either express or implied, is granted under any patent right, copyright, mask work right, or other intellectual property right relating to any combination, machine, or process in which TI components or services are used. Information published by TI regarding third-party products or services does not constitute a license to use such products or services or a warranty or endorsement thereof. Use of such information may require a license from a third party under the patents or other intellectual property of the third party, or a license from TI under the patents or other intellectual property of TI.

Reproduction of significant portions of TI information in TI data books or data sheets is permissible only if reproduction is without alteration and is accompanied by all associated warranties, conditions, limitations, and notices. TI is not responsible or liable for such altered documentation. Information of third parties may be subject to additional restrictions.

Resale of TI components or services with statements different from or beyond the parameters stated by TI for that component or service voids all express and any implied warranties for the associated TI component or service and is an unfair and deceptive business practice. TI is not responsible or liable for any such statements.

Buyer acknowledges and agrees that it is solely responsible for compliance with all legal, regulatory and safety-related requirements concerning its products, and any use of TI components in its applications, notwithstanding any applications-related information or support that may be provided by TI. Buyer represents and agrees that it has all the necessary expertise to create and implement safeguards which anticipate dangerous consequences of failures, monitor failures and their consequences, lessen the likelihood of failures that might cause harm and take appropriate remedial actions. Buyer will fully indemnify TI and its representatives against any damages arising out of the use of any TI components in safety-critical applications.

In some cases, TI components may be promoted specifically to facilitate safety-related applications. With such components, TI's goal is to help enable customers to design and create their own end-product solutions that meet applicable functional safety standards and requirements. Nonetheless, such components are subject to these terms.

No TI components are authorized for use in FDA Class III (or similar life-critical medical equipment) unless authorized officers of the parties have executed a special agreement specifically governing such use.

Only those TI components which TI has specifically designated as military grade or "enhanced plastic" are designed and intended for use in military/aerospace applications or environments. Buyer acknowledges and agrees that any military or aerospace use of TI components which have **not** been so designated is solely at the Buyer's risk, and that Buyer is solely responsible for compliance with all legal and regulatory requirements in connection with such use.

TI has specifically designated certain components as meeting ISO/TS16949 requirements, mainly for automotive use. In any case of use of non-designated products, TI will not be responsible for any failure to meet ISO/TS16949.

### Products

Audio	<a href="http://www.ti.com/audio">www.ti.com/audio</a>
Amplifiers	<a href="http://amplifier.ti.com">amplifier.ti.com</a>
Data Converters	<a href="http://dataconverter.ti.com">dataconverter.ti.com</a>
DLP® Products	<a href="http://www.dlp.com">www.dlp.com</a>
DSP	<a href="http://dsp.ti.com">dsp.ti.com</a>
Clocks and Timers	<a href="http://www.ti.com/clocks">www.ti.com/clocks</a>
Interface	<a href="http://interface.ti.com">interface.ti.com</a>
Logic	<a href="http://logic.ti.com">logic.ti.com</a>
Power Mgmt	<a href="http://power.ti.com">power.ti.com</a>
Microcontrollers	<a href="http://microcontroller.ti.com">microcontroller.ti.com</a>
RFID	<a href="http://www.ti-rfid.com">www.ti-rfid.com</a>
OMAP Applications Processors	<a href="http://www.ti.com/omap">www.ti.com/omap</a>
Wireless Connectivity	<a href="http://www.ti.com/wirelessconnectivity">www.ti.com/wirelessconnectivity</a>

### Applications

Automotive and Transportation	<a href="http://www.ti.com/automotive">www.ti.com/automotive</a>
Communications and Telecom	<a href="http://www.ti.com/communications">www.ti.com/communications</a>
Computers and Peripherals	<a href="http://www.ti.com/computers">www.ti.com/computers</a>
Consumer Electronics	<a href="http://www.ti.com/consumer-apps">www.ti.com/consumer-apps</a>
Energy and Lighting	<a href="http://www.ti.com/energy">www.ti.com/energy</a>
Industrial	<a href="http://www.ti.com/industrial">www.ti.com/industrial</a>
Medical	<a href="http://www.ti.com/medical">www.ti.com/medical</a>
Security	<a href="http://www.ti.com/security">www.ti.com/security</a>
Space, Avionics and Defense	<a href="http://www.ti.com/space-avionics-defense">www.ti.com/space-avionics-defense</a>
Video and Imaging	<a href="http://www.ti.com/video">www.ti.com/video</a>

### TI E2E Community

[e2e.ti.com](http://e2e.ti.com)

## Looking for pricing, stock, or lifecycle information?

Click below to explore more details on WIN SOURCE:

 [View SN74LS624DR on WIN SOURCE](#)

 [Texas Instruments](#) Information

## Optimize Your Supply Chain with WIN SOURCE Solutions

-  Global Sourcing Solution
-  Obsolete Management
-  Cost Control Management
-  Shortage Management
-  Alternative Solution
-  Excess Inventory Management