



**THE DATASHEET OF
MAX4032EUT+T**





5V, 6dB Video Buffer with Sync-Tip Clamp, Output Sag Correction, and 150nA Shutdown Current

MAX4032

General Description

The MAX4032 5V, 6dB video buffer with sync-tip clamp, output sag correction, and low-power shutdown mode is available in tiny SOT23 and SC70 packages. The sag-corrected output of the MAX4032 is designed to drive AC-coupled, 150Ω back-terminated video loads in portable video applications such as digital still cams, portable DVD players, digital camcorders, PDAs, video-enabled cell phones, portable game systems, and notebook computers. The sag correction feature introduces low-frequency compensation that reduces the value of the normally bulky and expensive 330μF AC-coupling capacitor to two small, less expensive 22μF capacitors. The input clamp positions the video waveform at the output and allows the MAX4032 to be used as either an AC- or DC-coupled output driver.

The MAX4032 operates from a single +5V supply and consumes only 6.5mA of supply current. The low-power shutdown mode reduces the supply current to 150nA, making the MAX4032 ideal for low-voltage, battery-powered video applications.

The MAX4032 is available in tiny 6-pin SOT23 and SC70 packages and is specified over the extended -40°C to +85°C temperature range.

Applications

Portable Video/Game Systems/DVD Players
 Digital Camcorders/Televisions/Still Cameras
 PDAs
 Video-Enabled Cell Phones
 Notebook Computers
 Portable/Flat-Panel Displays

Pin Configuration

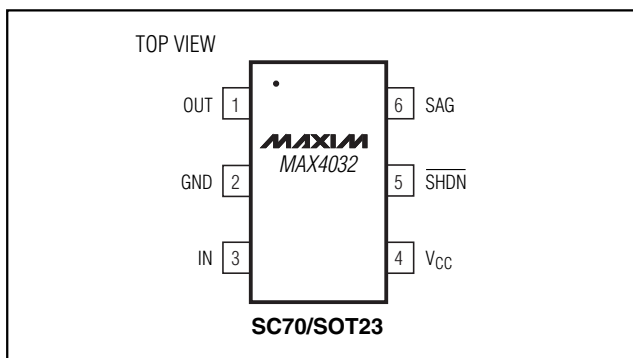

Features

- ◆ Single +5V Operation
- ◆ Input Sync-Tip Clamp
- ◆ AC- or DC-Coupled Output
- ◆ Low-Power Shutdown Mode Reduces Supply Current to 150nA
- ◆ SAG Correction Reduces Output-Coupling Capacitors from 330μF to 22μF
- ◆ Available in Space-Saving SOT23 and SC70 Packages

Ordering Information

PART	TEMP RANGE	PIN-PACKAGE	TOP MARK
MAX4032EXT-T	-40°C to +85°C	6 SC70-6	ACC
MAX4032EUT-T	-40°C to +85°C	6 SOT23-6	ABSP

Block Diagram

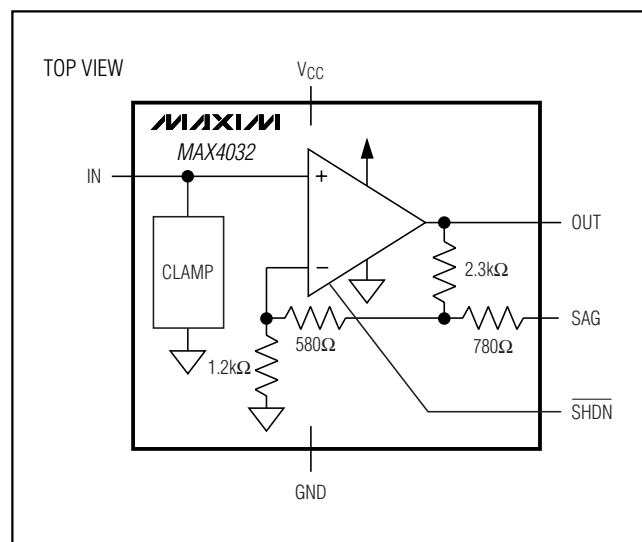

5V, 6dB Video Buffer with Sync-Tip Clamp, Output Sag Correction, and 150nA Shutdown Current

ABSOLUTE MAXIMUM RATINGS

V _{CC} to GND	-0.3V to +6V	Operating Temperature Range	-40°C to +85°C
OUT, SAG, $\overline{\text{SHDN}}$ to GND	-0.3V to (V _{CC} + 0.3V)	Junction Temperature	+150°C
IN to GND (Note 1)	V _{CLP} to (V _{CC} + 0.3V)	Storage Temperature Range	-65°C to +150°C
IN Short-Circuit Duration from -0.3V to V _{CLP}	1min	Lead Temperature (soldering, 10s)	+300°C
Output Short-Circuit Duration to V _{CC} or GND	Continuous		
Continuous Power Dissipation (T _A = +70°C)			
6-Pin SOT23 (derate 8.7mW/°C above +70°C)	695mW		
6-Pin SC70 (derate 3.1mW/°C above +70°C)	245mW		

Note 1: V_{CLP} is the input clamp voltage as defined in the DC Electrical Characteristics table.

Stresses beyond those listed under "Absolute Maximum Ratings" may cause permanent damage to the device. These are stress ratings only, and functional operation of the device at these or any other conditions beyond those indicated in the operational sections of the specifications is not implied. Exposure to absolute maximum rating conditions for extended periods may affect device reliability.

DC ELECTRICAL CHARACTERISTICS

(V_{CC} = 5.0V, GND = 0V, C_{IN} = 0.1μF from IN to GND, R_L = infinity to GND, SAG shorted to OUT, $\overline{\text{SHDN}}$ = 5.0V, T_A = -40°C to +85°C. Typical values are at T_A = +25°C, unless otherwise noted.) (Note 2)

PARAMETER	SYMBOL	CONDITIONS		MIN	TYP	MAX	UNITS
Supply Voltage Range	V _{CC}	Guaranteed by PSRR		4.5		5.5	V
Quiescent Supply Current	I _{CC}	V _{IN} = V _{CLP}			6.5	10	mA
Shutdown Supply Current	I _{SHDN}	$\overline{\text{SHDN}}$ = 0V			0.15	1	μA
Input Clamp Voltage	V _{CLP}	Input referred		0.27	0.38	0.47	V
Input Voltage Range	V _{IN}	Inferred from voltage gain (Note 3)		V _{CLP}		1.45	V
Input Bias Current	I _{BIAS}	V _{IN} = 1.45V			22.5	35	μA
Input Resistance		V _{CLP} + 0.5V < V _{IN} < V _{CLP} + 1V			3		MΩ
Voltage Gain	A _V	R _L = 150Ω to GND, 0.5V < V _{IN} < 1.45V (Note 4)		1.9	2	2.1	V/V
Power-Supply Rejection Ratio	PSRR	4.5V < V _{CC} < 5.5V		60	80		dB
Output Voltage High Swing	V _{OH}	R _L = 150Ω to GND		4.3	4.6		V
Output Voltage Low Swing	V _{OL}	R _L = 150Ω to GND			V _{CLP}	0.47	V
Output Current	I _{OUT}	Sourcing, R _L = 20Ω to GND		45	85		mA
		Sinking, R _L = 20Ω to V _{CC}		40	85		
Output Short-Circuit Current	I _{SC}	OUT shorted to V _{CC} or GND			110		mA
$\overline{\text{SHDN}}$ Logic-Low Threshold	V _{IL}					V _{CC} x 0.3	V
$\overline{\text{SHDN}}$ Logic-High Threshold	V _{IH}					V _{CC} x 0.7	V
$\overline{\text{SHDN}}$ Input Current	I _{IH} , I _{IL}				0.003	1	μA
Shutdown Output Impedance	R _{OUT} (Disabled)	$\overline{\text{SHDN}}$ = 0V	At DC		4		kΩ
			At 3.58MHz or 4.43MHz		2		

5V, 6dB Video Buffer with Sync-Tip Clamp, Output Sag Correction, and 150nA Shutdown Current

MAX4032

AC ELECTRICAL CHARACTERISTICS

($V_{CC} = 5.0V$, $GND = 0V$, $C_{OUT} = C_{SAG} = 22\mu F$, $C_{IN} = 0.1\mu F$, $R_{IN} = 75\Omega$ to GND, $R_L = 150\Omega$ to GND, $\overline{SHDN} = 5.0V$, $T_A = +25^\circ C$, unless otherwise noted.)

PARAMETER	SYMBOL	CONDITIONS	MIN	TYP	MAX	UNITS
Small-Signal -3dB Bandwidth	BW _{SS}	$V_{OUT} = 100mV_{P-P}$		55		MHz
Large-Signal -3dB Bandwidth	BW _{LS}	$V_{OUT} = 2V_{P-P}$		45		MHz
Small-Signal 0.1dB Gain Flatness	BW _{0.1dBSS}	$V_{OUT} = 100mV_{P-P}$		18		MHz
Large-Signal 0.1dB Gain Flatness	BW _{0.1dBLS}	$V_{OUT} = 2V_{P-P}$		17		MHz
Slew Rate	SR	$V_{OUT} = 2V$ step		275		V/ μs
Settling Time to 0.1%	t_s	$V_{OUT} = 2V$ step		25		ns
Power-Supply Rejection Ratio	PSRR	$f = 100kHz$		50		dB
Output Impedance	Z_{OUT}	$f = 5MHz$		2.5		Ω
Differential Gain	DG	NTSC		0.4		%
Differential Phase	DP	NTSC		0.6		Degrees
Group Delay	D/dT	$f = 3.58MHz$ or $4.43MHz$		20		ns
Peak Signal to RMS Noise	SNR	$V_{IN} = 1V_{P-P}$, 10MHz BW		65		dB
Droop		$C_{IN} = 0.1\mu F$ (Note 4)		2	3	%
\overline{SHDN} Enable Time	t_{ON}	$V_{IN} = V_{CLP} + 1V$, $\overline{SHDN} = 5V$, V_{OUT} settled to within 1% of the final voltage		250		ns
\overline{SHDN} Disable Time	t_{OFF}	$V_{IN} = V_{CLP} + 1V$, $\overline{SHDN} = 0V$, V_{OUT} settled to below 1% of the output voltage		50		ns

Note 2: All devices are 100% production tested at $T_A = +25^\circ C$. Specifications over temperature limits are guaranteed by design.

Note 3: Voltage gain (A_V) is referenced to the clamp voltage, i.e., an input voltage of $V_{IN} = V_{CLP} + V_I$ would produce an output voltage of $V_{OUT} = V_{CLP} + A_V \times V_I$.

Note 4: Droop is guaranteed by the input bias current specification.

5V, 6dB Video Buffer with Sync-Tip Clamp, Output Sag Correction, and 150nA Shutdown Current

Typical Operating Characteristics

($V_{CC} = 5.0V$, $GND = 0V$, $C_{OUT} = C_{SAG} = 22\mu F$, $C_{IN} = 0.1\mu F$, $R_{IN} = 75\Omega$ to GND , $R_L = 150\Omega$ to GND , $SHDN = V_{CC}$, $T_A = +25^\circ C$, unless otherwise noted.)

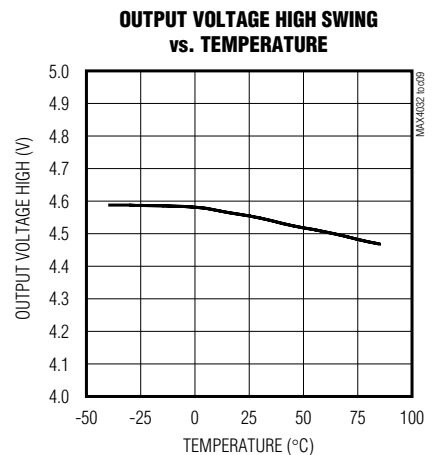
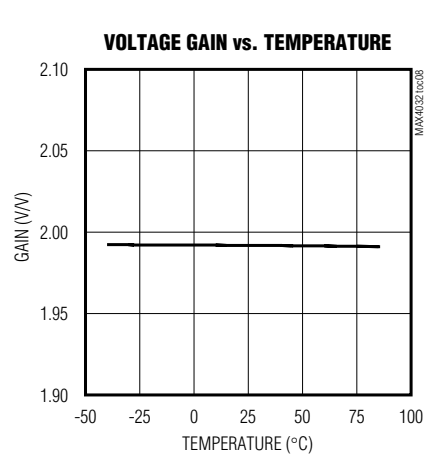
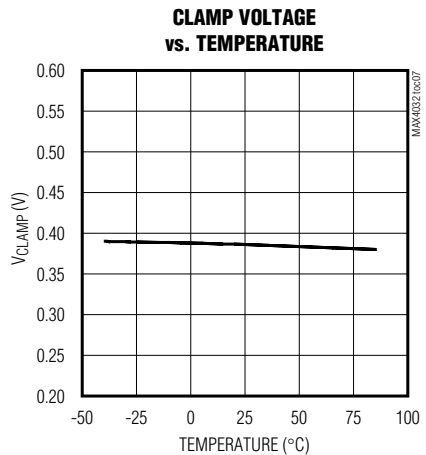
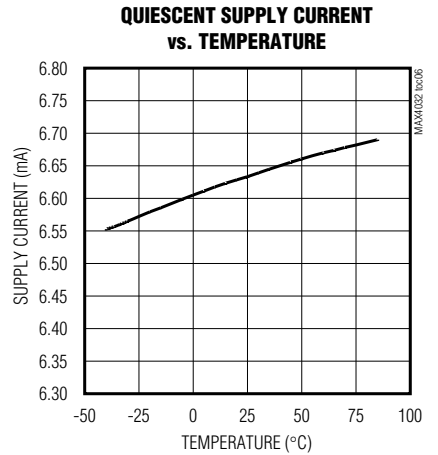
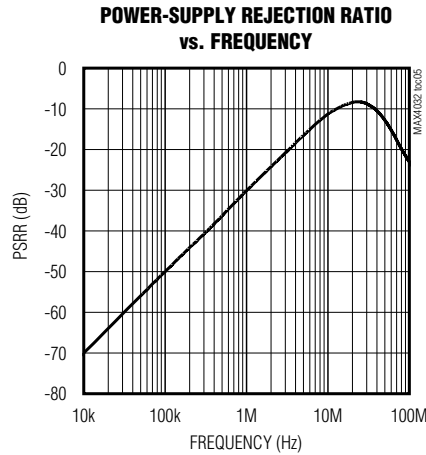
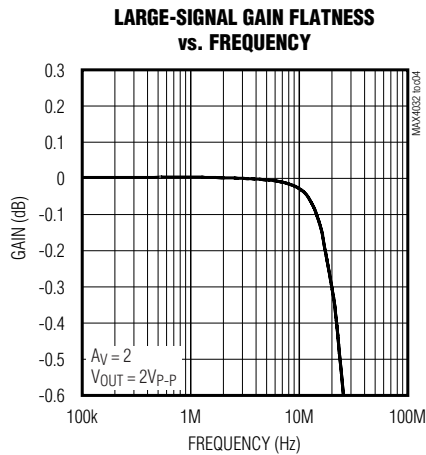
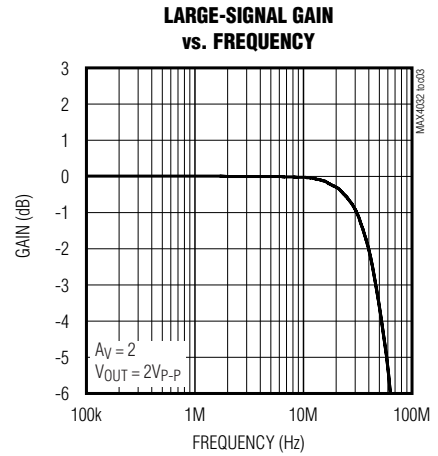
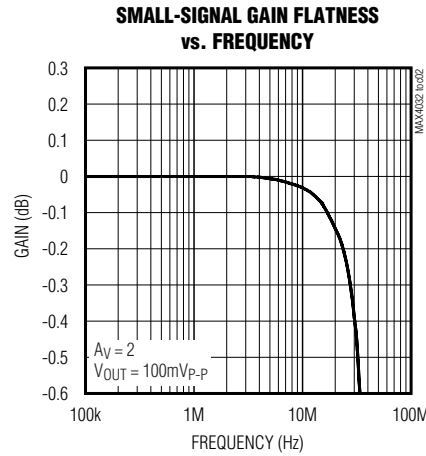
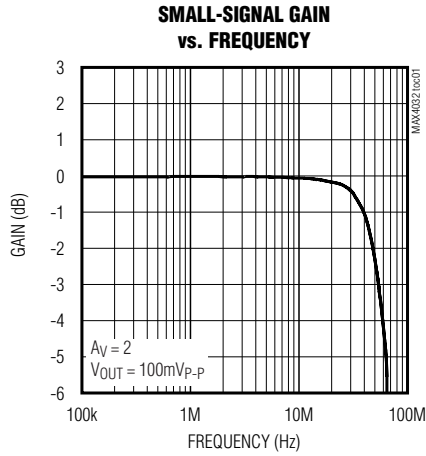

5V, 6dB Video Buffer with Sync-Tip Clamp, Output Sag Correction, and 150nA Shutdown Current

Typical Operating Characteristics (continued)

($V_{CC} = 5.0V$, $GND = 0V$, $C_{OUT} = C_{SAG} = 22\mu F$, $C_{IN} = 0.1\mu F$, $R_{IN} = 75\Omega$ to GND , $R_L = 150\Omega$ to GND , $\overline{SHDN} = V_{CC}$, $T_A = +25^\circ C$, unless otherwise noted.)

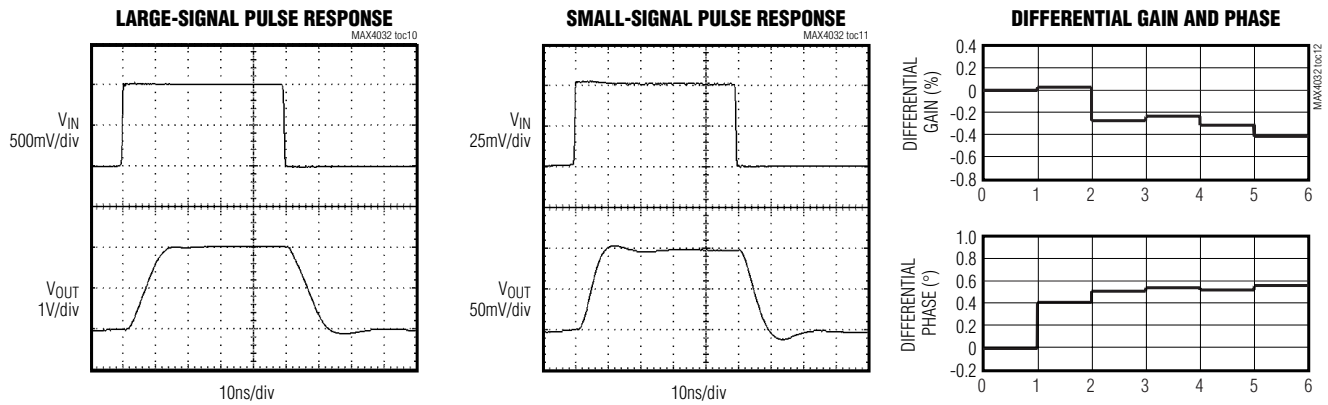

Pin Description

PIN	NAME	FUNCTION
1	OUT	Video Output
2	GND	Ground
3	IN	Video Input
4	V_{CC}	Power-Supply Voltage. Bypass with a 0.1 μF capacitor to ground as close to the pin as possible.
5	\overline{SHDN}	Shutdown. Pull \overline{SHDN} low to place the MAX4032 in low-power shutdown mode.
6	SAG	Sag Correction

Typical Application Circuit

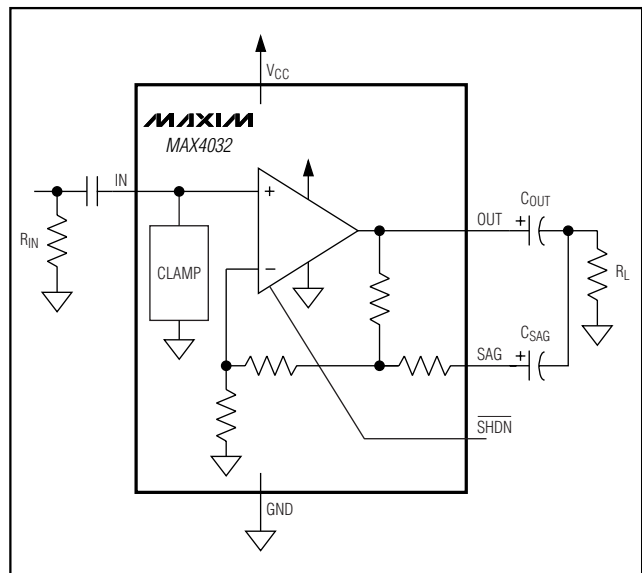

5V, 6dB Video Buffer with Sync-Tip Clamp, Output Sag Correction, and 150nA Shutdown Current

Detailed Description

The MAX4032 5V, 6dB video buffer with sync-tip clamp, output sag correction, and low-power shutdown mode is available in tiny SOT23 and SC70 packages. The sag-corrected output of the MAX4032 is designed to drive AC-coupled, 150Ω back-terminated video loads in portable video applications such as digital still cams, portable DVD players, digital camcorders, PDAs, video-enabled cell phones, portable game systems, and notebook computers. The sag correction feature introduces low-frequency compensation that reduces the value of the normally bulky and expensive 330μF AC-coupling capacitor to two small, less expensive 22μF capacitors. The input clamp positions the video waveform at the output and allows the MAX4032 to be used as either an AC- or DC-coupled output driver.

The MAX4032 operates from a single 5V supply and consumes only 6.5mA of supply current. The low-power shutdown mode reduces the supply current to 150nA, making the MAX4032 ideal for low-voltage, battery-powered video applications.

The input signal to the MAX4032 is AC-coupled through a capacitor into an active sync-tip clamp circuit, which places the minimum of the video signal at approximately 0.38V. The output buffer amplifies the video signal while still maintaining the 0.38V clamp voltage at the output. For example, if $V_{IN} = 0.38V$, then $V_{OUT} = 0.38V$. If $V_{IN} = (0.38V + 1V) = 1.38V$, then $V_{OUT} = (0.38V + 2 \times (1V)) = 2.38V$ when SAG is shorted OUT.

There are two common output connections for the MAX4032:

- 1) SAG is shorted to OUT and 150Ω is directly connected from OUT to ground (see Figure 2).
- 2) Two capacitors and 150Ω are connected between OUT, SAG, and ground (see Figure 3).

Sag Correction

Sag correction refers to the low-frequency compensation of the highpass filter formed by the 150Ω load of a back-terminated coax and the output-coupling capacitor. This break point must be low enough in frequency to pass the Vertical Sync Interval (<25Hz for PAL and <30Hz for NTSC) to avoid Field Tilt. Traditionally, the break point is made <3~5Hz, and the coupling capacitor must be very large, typically >330μF. The MAX4032 reduces the value of this coupling capacitor, replacing it with a pair of 22μF capacitors. This is done by putting a resistor network in series with the feedback, raising the gain, and creating a high-impedance node at the SAG output. This node is AC-coupled to the load in par-

allel with the normal output, as shown in Figure 3. This allows the use of two smaller capacitors (C_{OUT} and C_{SAG}), typically 22μF, substantially reducing the size of the interface caps and their cost while retaining the low-frequency response.

The minimum value of the output-coupling capacitor is a function of the acceptable Field Tilt. In Figure 1, the Field Tilt is given for several values of capacitance from 10μF to 47μF for comparison. Although values lower than 22μF may have acceptable Field Tilt, they are not recommended, since tolerance, aging, and voltage and temperature coefficients reduce the capacitance in actual applications. Increasing the output-coupling capacitors beyond 47μF does not improve performance.

Shutdown Mode

The MAX4032 features a low-power shutdown mode ($I_{SHDN} = 150nA$) for battery-powered/portable applications. Pulling the \overline{SHDN} pin high enables the output. Connecting the \overline{SHDN} pin to ground (GND) disables the output and places the MAX4032 into a low-power shutdown mode.

Applications Information

Input Coupling the MAX4032

The MAX4032 input must be AC-coupled because the input capacitor stores the clamp voltage. The MAX4032 requires a typical value of 0.1μF for the input clamp to meet the Line Droop specification. A minimum of a ceramic capacitor with an X7R temperature coefficient is recommended to avoid temperature-related problems with Line Droop. For extended temperature operation, such as outdoor applications, or where the impressed

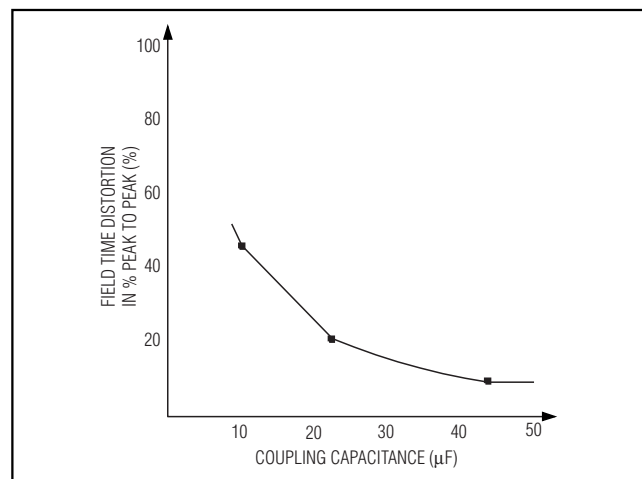

Figure 1. Field Tilt vs. Output-Coupling Capacitance

5V, 6dB Video Buffer with Sync-Tip Clamp, Output Sag Correction, and 150nA Shutdown Current

MAX4032

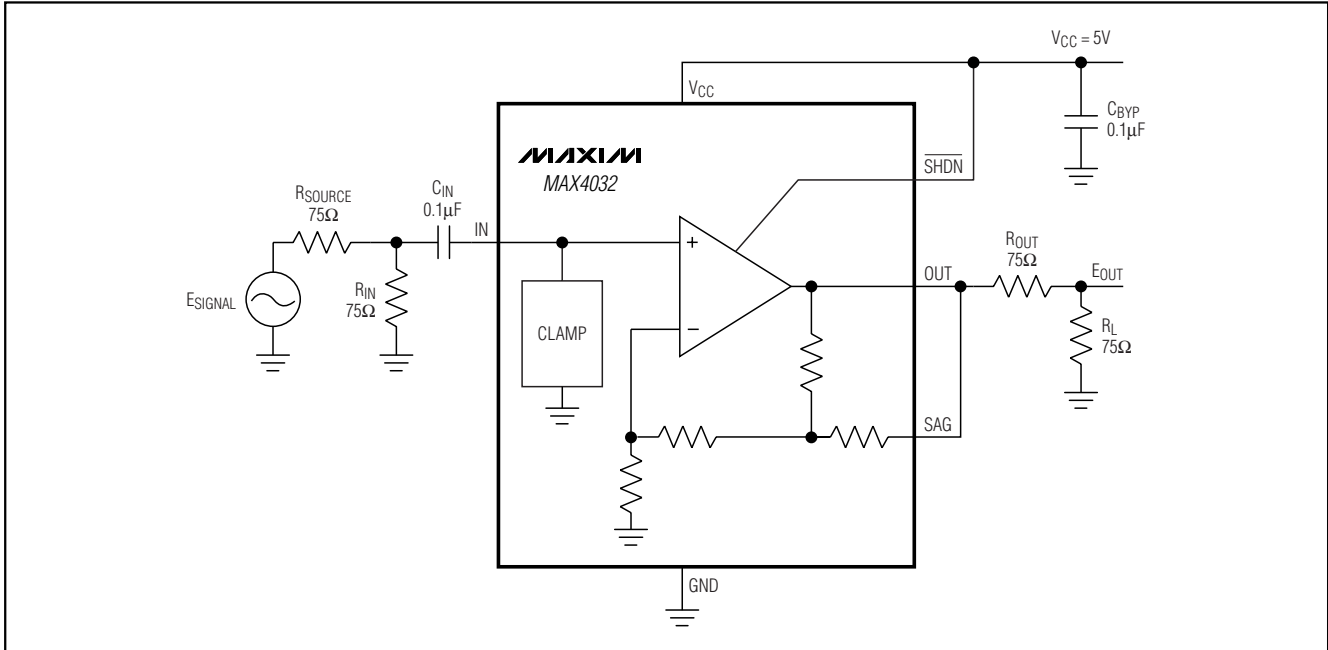

Figure 2. DC-Coupling the MAX4032

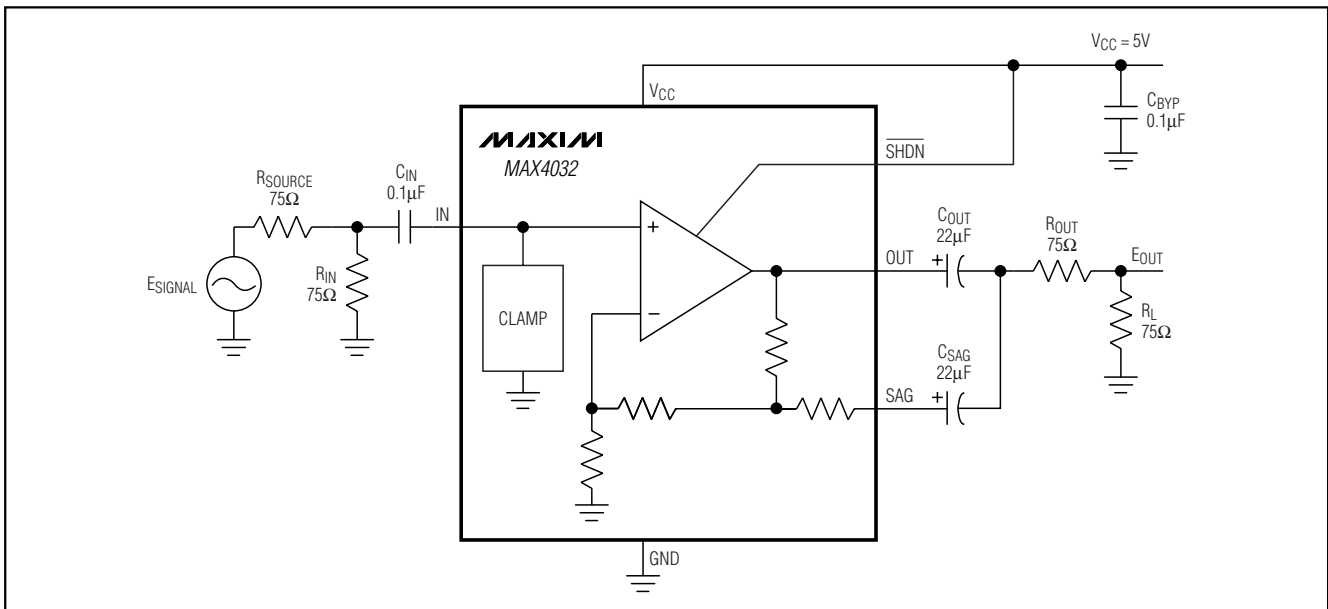

Figure 3. AC-Coupling the MAX4032

5V, 6dB Video Buffer with Sync-Tip Clamp, Output Sag Correction, and 150nA Shutdown Current

voltage is close to the rated voltage of the capacitor, a film dielectric is recommended. Increasing the capacitor value slows the clamp capture time. Values above 0.5 μ F should be avoided since they do not improve the clamp's performance.

The active sync-tip clamp also requires that the input impedance seen by the input capacitor be less than 100 Ω typically to function properly. This is easily met by the 75 Ω input resistor prior to the input-coupling capacitor and the back termination from a prior stage. Insufficient input resistance to ground causes the MAX4032 to appear to oscillate. Never operate the MAX4032 in this mode.

Output Coupling the MAX4032

The output of the MAX4032 can be AC- or DC-coupled to the load. In the DC-coupled mode, the MAX4032 provides accurate sync-tip clamping for single-supply operation and still can drive a 150 Ω , back-terminated load. In the AC-coupled mode, the MAX4032 allows the use of minimal size capacitors to drive a back-terminated video load of 150 Ω .

DC-Coupling the Output

By shorting SAG to OUT, the device becomes an amplifier with DC restore, optimally placing the video within the dynamic range of the output. In this mode, the MAX4032 can be used as the input conditioner for a video signal, providing gain and biasing in single-supply applications. DC-coupling also improves the MAX4032's performance in terms of differential gain and phase. This reflects the improvement in the low-frequency response due to DC-coupling.

AC-Coupling the Output

The MAX4032's output is configured to support AC-coupling with minimal capacitance. This is called "sag correction." It refers to the improved bandwidth achieved by using two smaller capacitors to replace a single large capacitor shown in Figure 3.

Layout and Power-Supply Bypassing

The MAX4032 operates from a single 5V supply. Bypass the supply with a 0.1 μ F capacitor as close to the pin as possible. Maxim recommends using microstrip and stripline techniques to obtain full bandwidth. To ensure that the PC board does not degrade the device's performance, design it for a frequency greater than 1GHz. Pay careful attention to inputs and outputs to avoid large parasitic capacitance. Whether or not you use a constant-impedance board, observe the following design guidelines:

- Do not use wire-wrap boards; they are too inductive.
- Do not use IC sockets; they increase parasitic capacitance and inductance.
- Use surface-mount instead of through-hole components for better, high-frequency performance.
- Use a PC board with at least two layers; it should be as free from voids as possible.
- Keep signal lines as short and as straight as possible. Do not make 90° turns; round all corners.

Chip Information

TRANSISTOR COUNT: 755

PROCESS: BiCMOS

5V, 6dB Video Buffer with Sync-Tip Clamp, Output Sag Correction, and 150nA Shutdown Current

Package Information

(The package drawing(s) in this data sheet may not reflect the most current specifications. For the latest package outline information go to www.maxim-ic.com/packages.)

MAX4032

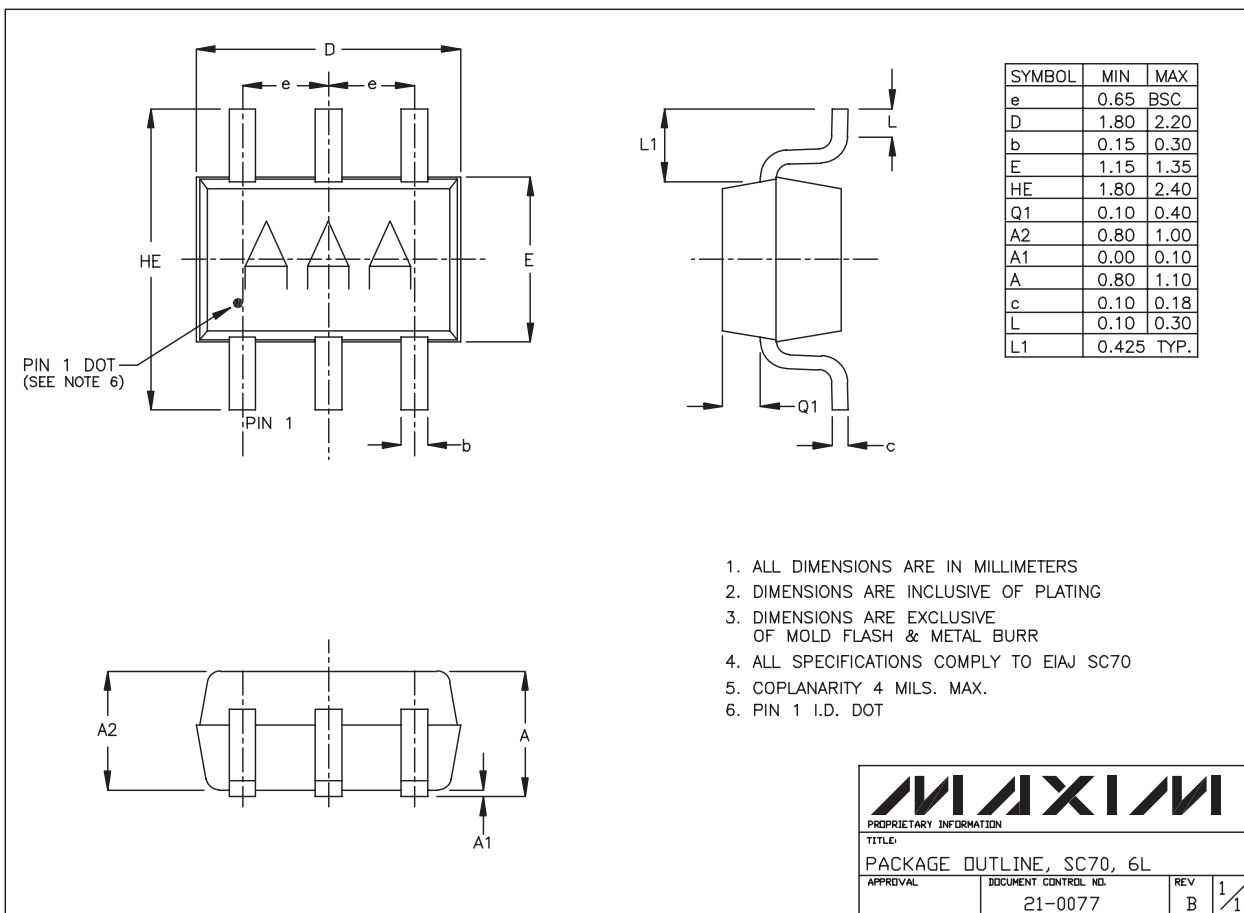

MAXIM

PROPRIETARY INFORMATION

TITLE:
PACKAGE OUTLINE, SC70, 6L

APPROVAL	DOCUMENT CONTROL NO. 21-0077	REV B	1/1
----------	---------------------------------	----------	-----

5V, 6dB Video Buffer with Sync-Tip Clamp, Output Sag Correction, and 150nA Shutdown Current

Package Information (continued)

(The package drawing(s) in this data sheet may not reflect the most current specifications. For the latest package outline information go to www.maxim-ic.com/packages.)

SYMBOL	MIN	MAX
A	0.90	1.45
A1	0.00	0.15
A2	0.90	1.30
b	0.35	0.50
C	0.08	0.20
D	2.80	3.00
E	2.60	3.00
E1	1.50	1.75
L	0.35	0.60
L1	0.60	REF.
e1	1.90	BSC.
e	0.95	BSC.
alpha	0°	10°

NOTES:

- ALL DIMENSIONS ARE IN MILLIMETERS.
- ▲ FOOT LENGTH MEASURED AT INTERCEPT POINT BETWEEN DATUM A & LEAD SURFACE.
- PACKAGE OUTLINE EXCLUSIVE OF MOLD FLASH & METAL BURR. MOLD FLASH, PROTRUSION OR METAL BURR SHOULD NOT EXCEED 0.25 MM.
- PACKAGE OUTLINE INCLUSIVE OF SOLDER PLATING.
- PIN 1 IS LOWER LEFT PIN WHEN READING TOP MARK FROM LEFT TO RIGHT. (SEE EXAMPLE TOP MARK)
- PIN 1 I.D. DOT IS 0.3 MM Ø MIN. LOCATED ABOVE PIN 1.
- MEETS JEDEC MO178, VARIATION AB.
- SOLDER THICKNESS MEASURED AT FLAT SECTION OF LEAD BETWEEN 0.08mm AND 0.15mm FROM LEAD TIP.
- LEAD TO BE COPLANAR WITHIN 0.1 MM.

6LSOT.EPS

<small>PROPRIETARY INFORMATION</small>	
TITLE: PACKAGE OUTLINE, SOT-23, 6L	
APPROVAL:	DOCUMENT CONTROL NO. 21-0058
REV. F	1/1

Maxim cannot assume responsibility for use of any circuitry other than circuitry entirely embodied in a Maxim product. No circuit patent licenses are implied. Maxim reserves the right to change the circuitry and specifications without notice at any time.

10 _____ **Maxim Integrated Products, 120 San Gabriel Drive, Sunnyvale, CA 94086 408-737-7600**

Looking for pricing, stock, or lifecycle information?

Click below to explore more details on WIN SOURCE:

- ⊖ [View MAX4032EUT+T on WIN SOURCE](#)
- ⊖ [Maxim Integrated Information](#)

Optimize Your Supply Chain with WIN SOURCE Solutions

- ✓ Global Sourcing Solution
- ✓ Obsolete Management
- ✓ Cost Control Management
- ✓ Shortage Management
- ✓ Alternative Solution
- ✓ Excess Inventory Management