



**THE DATASHEET OF
LM48413TL/NOPB**



LM48413 Boomer™ Audio Power Amplifier Series Ultra Low EMI, Filterless, 1.2W Stereo Class D Audio Power Amplifier with E²S and Texas Instruments 3D Enhancement

Check for Samples: [LM48413](#)

FEATURES

- E²S System Reduces EMI Preserving Audio Quality and Efficiency
- Output Short Circuit Protection
- Stereo Class D Operation
- No Output Filter Required
- Texas Instruments 3D Enhancement
- Minimum External Components
- Click and Pop Suppression
- Micro-Power Shutdown
- Available in Space-Saving Approximately 2mm x 2.2mm DSBGA Package

APPLICATIONS

- Mobile Phones
- PDAs
- Laptops

KEY SPECIFICATIONS

- Quiescent Power Supply Current at 3.6V Supply 4mA (Typ)
- Power Output at $V_{DD} = 5V$, $R_L = 8\Omega$, THD $\leq 1\%$ 1.2 W (Typ)
- Shutdown Current 0.03 μ A (Typ)
- Efficiency at 3.6V, 100mW into 8 Ω 80% (Typ)
- Efficiency at 3.6V, 500mW into 8 Ω 80% (Typ)
- Efficiency at 5V, 1W into 8 Ω 86% (Typ)

DESCRIPTION

The LM48413 is a single supply, high efficiency, 1.2W/channel, filterless switching audio amplifier. The LM48413 features Texas Instruments' Enhanced Emissions Suppression (E²S) system - a unique patented ultra low EMI, spread spectrum, PWM architecture. It significantly reduces RF emission while preserving audio quality and efficiency. The E²S system improves battery life, reduces external component count, board area consumption, system cost and product design cycle time. The LM48413TL is available in a micro-SMD package, further saving space.

The LM48413 is designed to meet the demands of mobile phones and other portable communication devices. Operating from a single 5V supply, the device is capable of delivering 1.2W/channel of continuous output power to a 8 Ω load with less than 1% THD+N. Flexible power supply requirements allow operation from 2.4V to 5.5V. The wide band spread spectrum architecture of the LM48413 reduces EMI-radiated emissions due to the modulator frequency.

The LM48413 features high efficiency compared with conventional Class AB amplifiers. The E²S system includes an advanced, patent-pending edge rate control (ERC) architecture that further reduce emissions by minimizing the high frequency components of the device output, while maintaining its high quality audio reproduction and high efficiency ($\eta = 85\%$ at $V_{DD} = 3.6V$, $P_O = 500mW$). The LM48413 also includes Texas Instruments' 3D audio enhancement that improves stereo sound quality. In devices where the left and right speakers are in close proximity, 3D enhancement affects channel specialization, widening the perceived soundstage.

Output short circuit protection prevents the device from being damaged during fault conditions. Superior click and pop suppression eliminates audible transients on power up/down and during shutdown. Shutdown control also provided to maximizes power savings.



Please be aware that an important notice concerning availability, standard warranty, and use in critical applications of Texas Instruments semiconductor products and disclaimers thereto appears at the end of this data sheet.

Boomer is a trademark of Texas Instruments.

All other trademarks are the property of their respective owners.

EMI Plot Using 6 inch Speaker Cables

Figure 1. EMI Radiation vs Frequency
 $V_{DD} = 3V, R_L = 15\mu H + 8\Omega + 15\mu H$

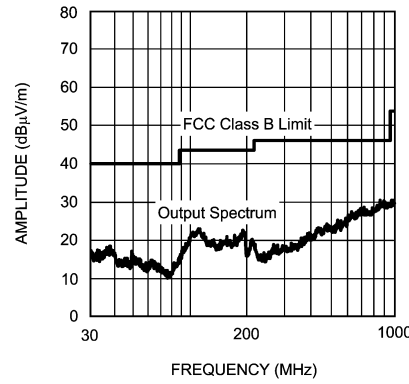

Typical Application

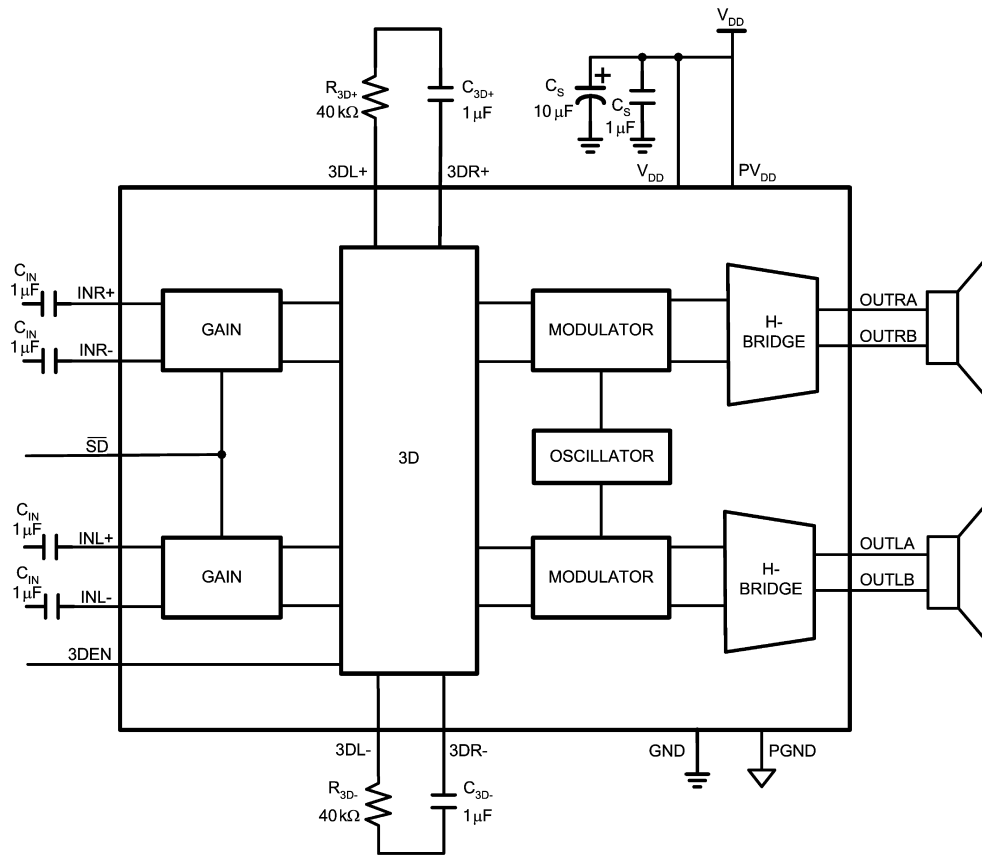
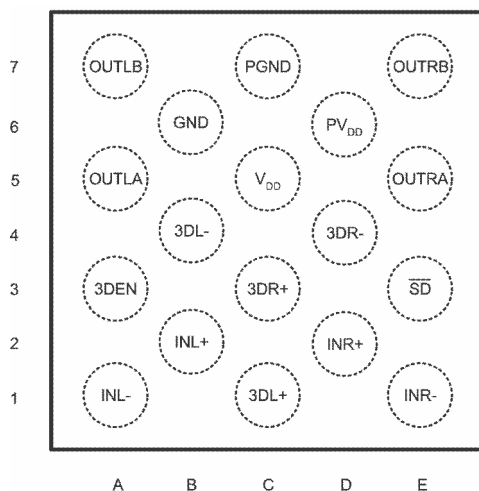

Figure 2. Typical Audio Amplifier Application Circuit

Connection Diagram



**Figure 3. 18 bump DSBGA package
Top View
See Package Number YZR0018**

BUMP DESCRIPTIONS

Bump	Name	Description
A1	INL-	Left Channel Inverting Input
A3	3DEN	3D Enable Input
A5	OUTLA	Left Channel Non-Inverting Output
A7	OUTLB	Left Channel Inverting Output
B2	INL+	Left Channel Non-Inverting Input
B4	3DL-	Left Channel inverting 3D connection. Connect to 3DR- through C _{3D-} and R _{3D-} .
B6	GND	Ground
C1	3DL+	Left Channel non-inverting 3D connection. Connect to 3DR+ through C _{3D+} and R _{3D+} .
C3	3DR+	Right Channel non-inverting 3D connection. Connect to 3DL+ through C _{3D+} and R _{3D+} .
C5	V _{DD}	Power Supply. Connect to PV _{DD} supplying same voltage.
C7	PGND	Power Ground
D2	INR+	Right Channel Non-inverting Input
D4	3DR-	Right Channel inverting 3D connection. Connect to 3DL- through C _{3D-} and R _{3D-} .
D6	PV _{DD}	Amplifier Power Supply
E1	INR-	Right Channel Inverting Input
E3	SD-bar	Connect to GND for disabling the device. Connect to V _{DD} for normal operation.
E5	OUTRA	Right Channel Non-inverting Output
E7	OUTRB	Right Channel Inverting Output



These devices have limited built-in ESD protection. The leads should be shorted together or the device placed in conductive foam during storage or handling to prevent electrostatic damage to the MOS gates.

Absolute Maximum Ratings⁽¹⁾⁽²⁾⁽³⁾

Supply Voltage ⁽¹⁾		6.0V
Storage Temperature		-65°C to +150°C
Input Voltage		-0.3V to V _{DD} + 0.3V
Power Dissipation ⁽⁴⁾		Internally Limited
ESD Rating ⁽⁵⁾		2000V
ESD Rating ⁽⁶⁾		200V
Junction Temperature		150°C
Thermal Resistance	θ_{JA}	47°C/W

- (1) "Absolute Maximum Ratings" indicate limits beyond which damage to the device may occur, including inoperability and degradation of device reliability and/or performance. Functional operation of the device and/or non-degradation at the *Absolute Maximum Ratings* or other conditions beyond those indicated in the *Recommended Operating Conditions* is not implied. The *Recommended Operating Conditions* indicate conditions at which the device is functional and the device should not be operated beyond such conditions. All voltages are measured with respect to the ground pin, unless otherwise specified.
- (2) The *Electrical Characteristics* tables list ensured specifications under the listed *Recommended Operating Conditions* except as otherwise modified or specified by the *Electrical Characteristics Conditions* and/or Notes. Typical specifications are estimations only and are not ensured.
- (3) If Military/Aerospace specified devices are required, please contact the Texas Instruments Sales Office/Distributors for availability and specifications.
- (4) The maximum power dissipation must be derated at elevated temperatures and is dictated by T_{JMAX}, θ_{JA} , and the ambient temperature, T_A. The maximum allowable power dissipation is P_{DMAX} = (T_{JMAX} - T_A) / θ_{JA} or the number given in *Absolute Maximum Ratings*, whichever is lower.
- (5) Human body model, applicable std. JESD22-A114C.
- (6) Machine model, applicable std. JESD22-A115-A. The ESD Machine Model rating of device bump E3 = 150V.

Operating Ratings⁽¹⁾⁽²⁾

Temperature Range	T _{MIN} ≤ T _A ≤ T _{MAX}	-40°C ≤ T _A ≤ 85°C
	Supply Voltage (V _{DD} , PV _{DD})	2.4V ≤ V _{DD} ≤ 5.5V

- (1) "Absolute Maximum Ratings" indicate limits beyond which damage to the device may occur, including inoperability and degradation of device reliability and/or performance. Functional operation of the device and/or non-degradation at the *Absolute Maximum Ratings* or other conditions beyond those indicated in the *Recommended Operating Conditions* is not implied. The *Recommended Operating Conditions* indicate conditions at which the device is functional and the device should not be operated beyond such conditions. All voltages are measured with respect to the ground pin, unless otherwise specified.
- (2) The *Electrical Characteristics* tables list ensured specifications under the listed *Recommended Operating Conditions* except as otherwise modified or specified by the *Electrical Characteristics Conditions* and/or Notes. Typical specifications are estimations only and are not ensured.

Electrical Characteristics $V_{DD} = PV_{DD} = 3.6V^{(1)(2)}$

 The following specifications apply for $R_L = 8\Omega^{(3)}$, $f = 1kHz$, unless otherwise specified. Limits apply for $T_A = 25^\circ C$.

Symbol	Parameter	Conditions	LM48413		Units (Limits)
			Typical	Limit	
			(4)	(5)	
V_{OS}	Differential Output Offset Voltage	$V_{IN} = 0$, $V_{DD} = 2.4V$ to $5.0V$	3		mV
I_{DD}	Quiescent Power Supply Current	$V_{IN} = 0$, No Load, $V_{SD} = V_{DD}$, $V_{DD} = 3.6V$ $V_{DD} = 5V$	4.3 5.2	5.5 7	mA (max) mA (max)
I_{SD}	Shutdown Current	$V_{SD} = GND$	0.03	1	μA (max)
V_{IH}	Logic Input High Voltage			1.4	V (min)
V_{IL}	Logic Input Low Voltage			0.4	V (max)
T_{WU}	Wake-Up Time		4		ms
A_V	Gain		24	23.5 24.5	dB (min) dB (max)
R_{IN}	Input Resistance		20		k Ω
P_O	Output Power (Per Channel)	THD $\leq 10\%$, $f = 1kHz$, 22kHz BW			
		$V_{DD} = 5V$	1.5		W
		$V_{DD} = 3.6V$	720	600	mW (min)
		$V_{DD} = 2.5V$	320		mW
		THD $\leq 1\%$, $f = 1kHz$, 22kHz BW			
		$V_{DD} = 5V$	1.2		W
		$V_{DD} = 3.6V$	600		mW
		$V_{DD} = 2.5V$	260		mW
THD+N	Total Harmonic Distortion + Noise	$P_O = 500mW/Ch$, $f = 1kHz$, 22kHz BW	0.03		%
		$P_O = 300mW/Ch$, $f = 1kHz$, 22kHz BW	0.03		%
PSRR	Power Supply Rejection Ratio	$V_{RIPPLE} = 200mV_{P-P}$ Sine, Inputs AC GND, $C_{IN} = 1\mu F$, input referred $f_{RIPPLE} = 217Hz$ $f_{RIPPLE} = 1kHz$	91		dB
			90		dB
CMRR	Common Mode Rejection Ratio	$V_{RIPPLE} = 1V_{P-P}$ $f_{RIPPLE} = 217Hz$	72		dB
η	Efficiency	$P_O = 1W/Ch$, $f = 1kHz$, $R_L = 8\Omega$, $V_{DD} = 5V$	86		%
X_{TALK}	Crosstalk	$P_O = 500mW/Ch$, $f = 1kHz$	93		dB
SNR	Signal-to-Noise Ratio	$V_{DD} = 5V$, $P_O = 1W$	88		dB
ϵ_{OS}	Output Noise	Input referred, A-Weighted	5		μV

- (1) "Absolute Maximum Ratings" indicate limits beyond which damage to the device may occur, including inoperability and degradation of device reliability and/or performance. Functional operation of the device and/or non-degradation at the Absolute Maximum Ratings or other conditions beyond those indicated in the Recommended Operating Conditions is not implied. The Recommended Operating Conditions indicate conditions at which the device is functional and the device should not be operated beyond such conditions. All voltages are measured with respect to the ground pin, unless otherwise specified.
- (2) The Electrical Characteristics tables list ensured specifications under the listed Recommended Operating Conditions except as otherwise modified or specified by the Electrical Characteristics Conditions and/or Notes. Typical specifications are estimations only and are not ensured.
- (3) R_L is a resistive load in series with two inductors to simulate an actual speaker load. For $R_L = 8\Omega$, the load is $15\mu H + 8\Omega + 15\mu H$.
- (4) Typical values represent most likely parametric norms at $T_A = +25^\circ C$, and at the Recommended Operation Conditions at the time of product characterization and are not ensured.
- (5) Datasheet min/max specification limits are ensured by test or statistical analysis.

Typical Performance Characteristics

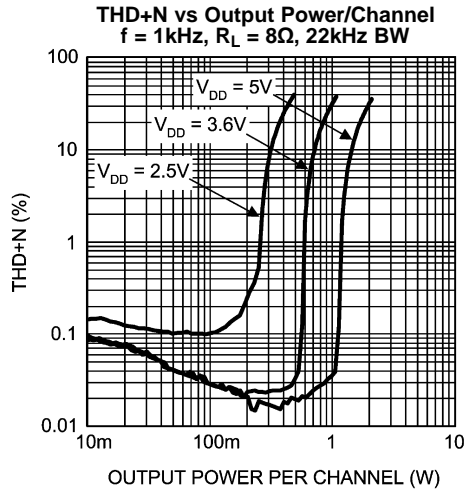

Figure 4.

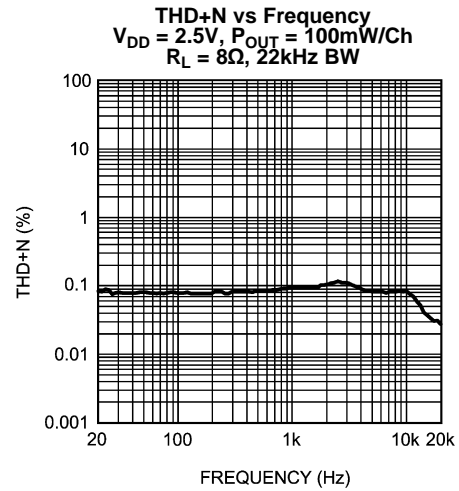

Figure 5.

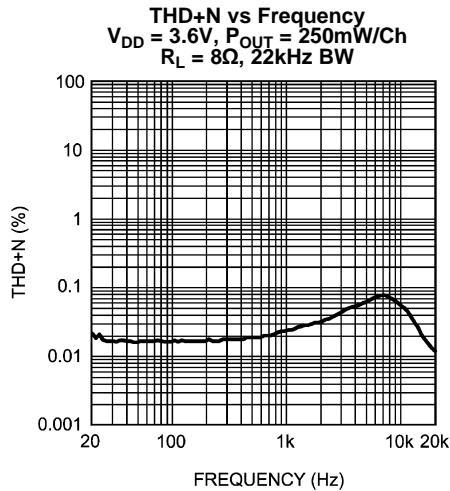

Figure 6.

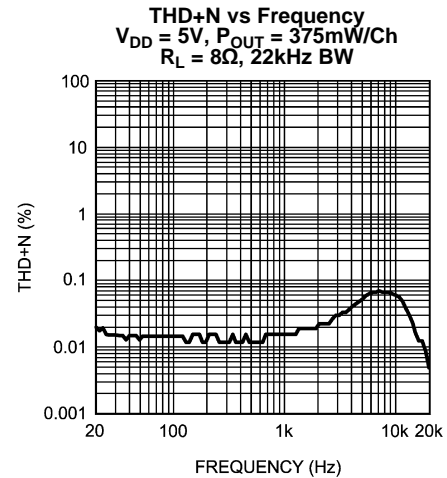

Figure 7.

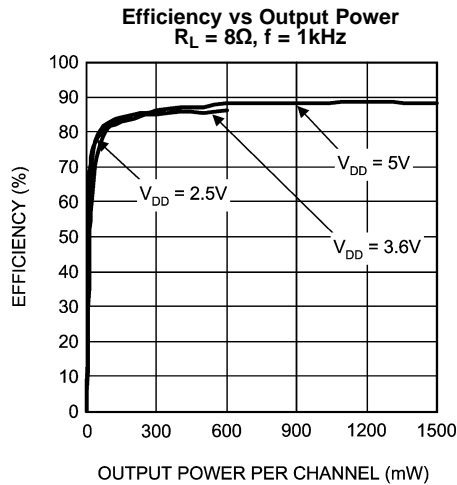

Figure 8.

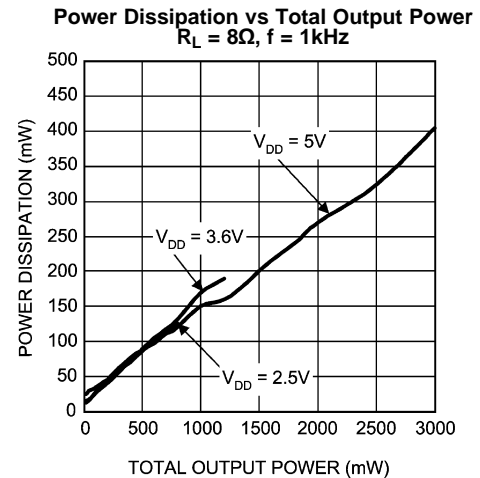

Figure 9.

Typical Performance Characteristics (continued)

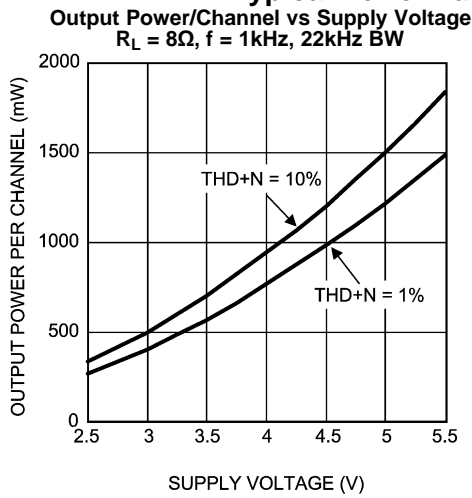

Figure 10.

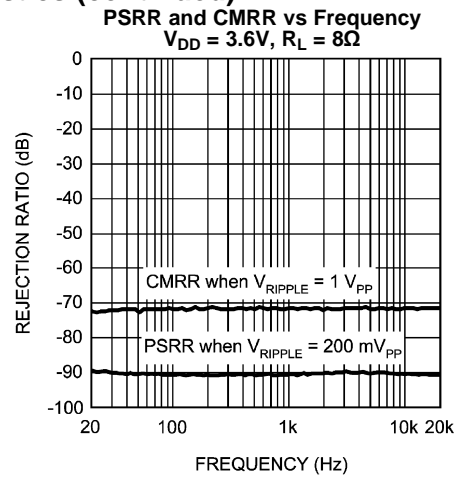

Figure 11.

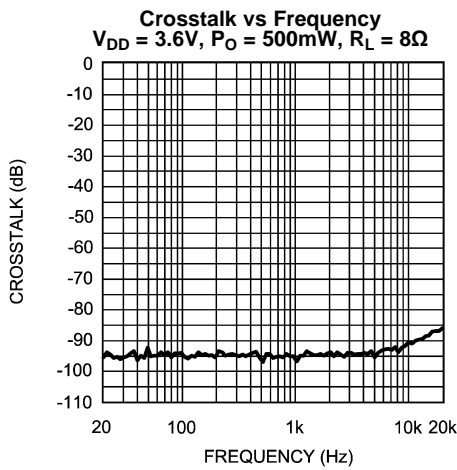

Figure 12.

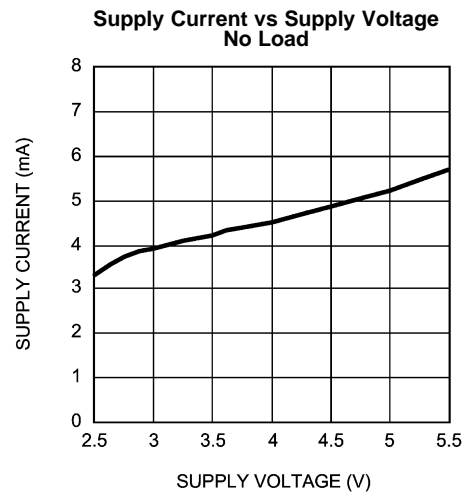

Figure 13.

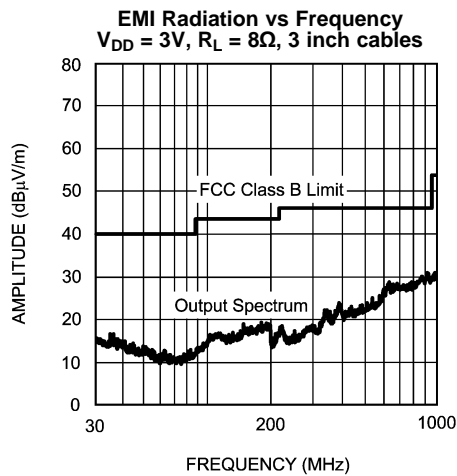

Figure 14.

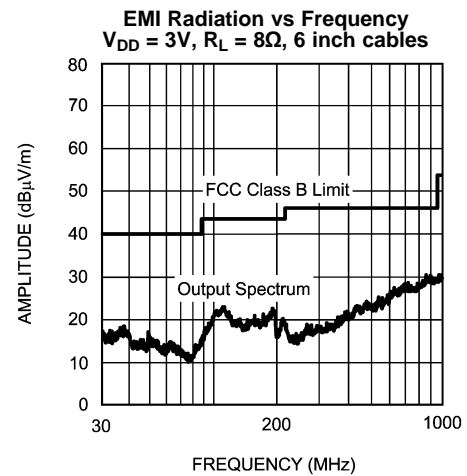

Figure 15.

Typical Performance Characteristics (continued)

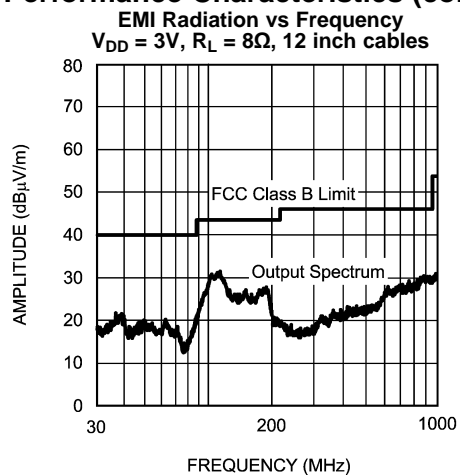

Figure 16.

APPLICATION INFORMATION

GENERAL AMPLIFIER FUNCTION

The LM48413 stereo Class D audio power amplifier features a filterless modulation scheme that reduces external component count, conserving board space and reducing system cost. The outputs of the device transition from PV_{DD} to GND with a 390kHz switching frequency. With no signal applied, the outputs switch with a 50% duty cycle, in phase, causing the two outputs to cancel. This cancellation results in no net voltage across the speaker, thus there is no current to the load in the idle state.

When an input signal is applied, the duty cycle (pulse width) of the LM48413 output's change. For increasing output voltage, the duty cycle of one side of each output increases, while the duty cycle of the other side of each output decreases. For decreasing output voltages, the converse occurs. The difference between the two pulse widths yields the differential output voltage.

SHUTDOWN FUNCTION

The LM48413 features a low current shutdown mode. Set $\overline{SD} = GND$ to disable the amplifier and reduce supply current to 0.03 μ A.

Switch \overline{SD} between GND and V_{DD} for minimum current consumption in shutdown. The LM48413 may be disabled with shutdown voltages in between GND and V_{DD} , but the idle current will be greater than the typical value. The LM48413 shutdown input has an internal 300k Ω pull-down resistor. The purpose of this resistor is to eliminate any unwanted state changes when this pin is floating. To minimize shutdown current, it should be driven to GND or left floating. If it is not driven to GND, or floating, a small increase in shutdown supply current will be noticed.

SPREAD SPECTRUM

The LM48413 outputs are modulated in spread spectrum scheme eliminating the need for output filters, ferrite beads or chokes. During its operation, the switching frequency varies randomly by 30% about a 390kHz center frequency, reducing the wideband spectral content and improving EMI emissions radiated by the speaker and associated cables and traces. A fixed frequency class D exhibits large amounts of spectral energy at multiples of the switching frequency. The spread spectrum architecture of the LM48413 spreads the same energy over a larger bandwidth. The cycle-to-cycle variation of the switching period does not affect the audio reproduction, efficiency, or PSRR.

ENHANCED EMISSIONS SUPPRESSION SYSTEM (E²S)

The LM48413 features Texas Instruments' patented E²S system that further reduces EMI, while maintaining high quality audio reproduction and efficiency. The advanced edge rate control (ERC) embedded within the E²S system works simultaneously with the spread spectrum already activated. The LM48413 ERC greatly reduces the high frequency components of the output square waves by controlling the output rise and fall times, slowing the transitions to reduce RF emissions, while maximizing THD+N and efficiency performance.

DIFFERENTIAL AMPLIFIER EXPLANATION

As logic supplies continue to shrink, system designers are increasingly turning to differential analog signal handling to preserve signal to noise ratios with restricted voltage swings. The LM48413 features two fully differential speaker amplifiers. A differential amplifier amplifies the difference between the two input signals. Traditional audio power amplifiers have typically offered only single-ended inputs resulting in a 6dB reduction of SNR relative to differential inputs. The LM48413 also offers the possibility of DC input coupling which eliminates the input coupling capacitors. A major benefit of the fully differential amplifier is the improved common mode rejection ratio (CMRR) over single-ended input amplifiers. The increased CMRR of the differential amplifier reduces sensitivity to ground offset related noise injection, especially important in noisy systems.

POWER DISSIPATION AND EFFICIENCY

The major benefit of a Class D amplifier is increased efficiency versus a Class AB. The efficiency of the LM48413 is attributed to the region of operation of the transistors in the output stage. The Class D output stage acts as current steering switches, consuming negligible amounts of power compared to a Class AB amplifier. Most of the power loss associated with the output stage is due to the IR loss of the MOSFET on-resistance, along with switching losses due to gate charge.

PROPER SELECTION OF EXTERNAL COMPONENTS

Power Supply Bypassing/Filtering

Proper power supply bypassing is important for low noise performance and high PSRR. Place the 1 μ F supply bypass capacitor as close to the device as possible. Traditionally, a pair of bypass capacitors with typical value 0.1 μ F and 10 μ F are applied to the supply rail for increasing stability. Nevertheless, these capacitors do not eliminate the need for bypassing of the LM48413 supply pins.

Input Capacitor Selection

Input capacitors may be required for some applications, or when the audio source is single-ended. Input capacitors block the DC component of the audio signal, eliminating any conflict between the DC component of the audio source and the bias voltage of the LM48413. The input capacitors create a high-pass filter with the input resistance R_{IN} . The -3dB point of the high-pass filter is found using [Equation 1](#) below.

$$f = 1 / 2\pi R_{IN} C_{IN} \quad (\text{Hz}) \quad (1)$$

The input capacitors can also be used to remove low frequency content from the audio signal. When the LM48413 is using a single-ended source, power supply noise on the ground is seen as an input signal. Setting the high-pass filter point above the power supply noise frequencies, 217Hz in a GSM phone, for example, filters out the noise such that it is not amplified and heard on the output. Capacitors with a tolerance of 10% or better are recommended for impedance matching and improved CMRR and PSRR.

Texas Instruments 3D Enhancement

The LM48413 features Texas Instruments' 3D enhancement effect that widens the perceived soundstage of a stereo audio signal. The 3D enhancement increases the apparent stereo channel separation, improving audio reproduction whenever the left and right speakers are too close to one another.

An external RC network shown in [Figure 2](#) is required to enable the 3D effect. Because the LM48413 is a fully differential amplifier, there are two separate RC networks, one for each stereo input pair (INL+ and INR+, and INL- and INR-). Set 3DEN high to enable the 3D effect. Set 3DEN low to disable the 3D effect.

The 3D RC network acts as a high-pass filter. The amount of the 3D effect is set by the R_{3D} resistor. Decreasing the value of R_{3D} increases the 3D effect. The C_{3D} capacitor sets the frequency at which the 3D effect occurs. Increasing the value of C_{3D} decreases the low frequency cutoff point, extending the 3D effect over a wider bandwidth. The low frequency cutoff point is given by [Equation 2](#):

$$f_{3D(-3dB)} = 1 / 2\pi(R_{3D})(C_{3D}) \quad (\text{Hz}) \quad (2)$$

Enabling the 3D effect increase the gain by a factor of $(1+40k\Omega/R_{3D})$. Setting R_{3D} to 40k Ω results in a gain increase of 6dB whenever the 3D effect is enabled. The [Equation 2](#) holds for both differential and single-end configuration. The recommended tolerance of the resistor value and capacitor value of the two RC networks are 5% and 10% respectively. Tolerance out of this range may affect the 3D gain and low frequency cut-off point too much. The desired sound quality of the 3D effect may not be obtained consequently.

SINGLE-ENDED AUDIO AMPLIFIER CONFIGURATION

The LM48413 is compatible with single-ended sources. When configured for single-ended inputs, input capacitors must be used to block and DC component at the input of the device. [Figure 17](#) shows the typical single-ended applications circuit.

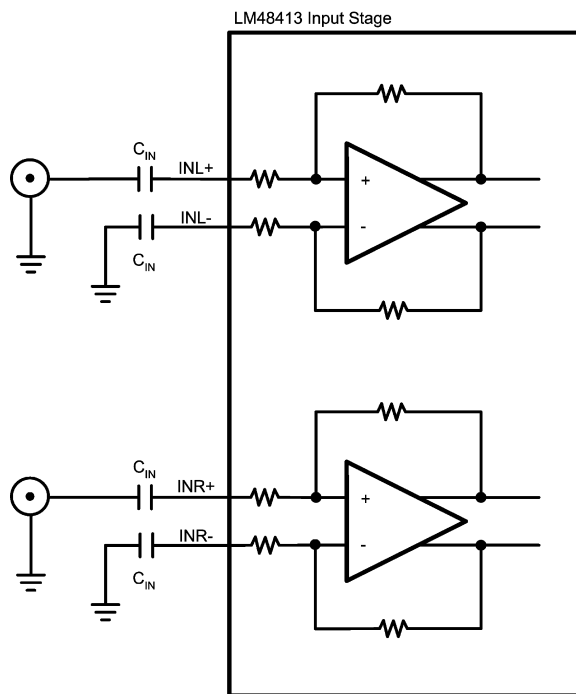

Figure 17. Single-Ended Circuit Diagram

AUDIO AMPLIFIER GAIN

The LM48413 has a fix gain value 24dB which is suitable for ordinary audio applications. To reduce the amplifier gain, insert two pairs of external input resistors with same value before the IC's input signal pins. Figure 18 show the configuration of these input resistors and the amplifier's internal gain setting. Accordingly, the overall amplifier gain is given by Equation 3:

$$A_V = 2 * (160k) / (20k + R_{IN}) \quad (3)$$

For example, if the gain to be set is 12dB, then A_V is equal to 4. Thus, Equation 3 the input resistors' value $R_{IN} = [(2 * 160k)/4] - 20k = 60k\Omega$.

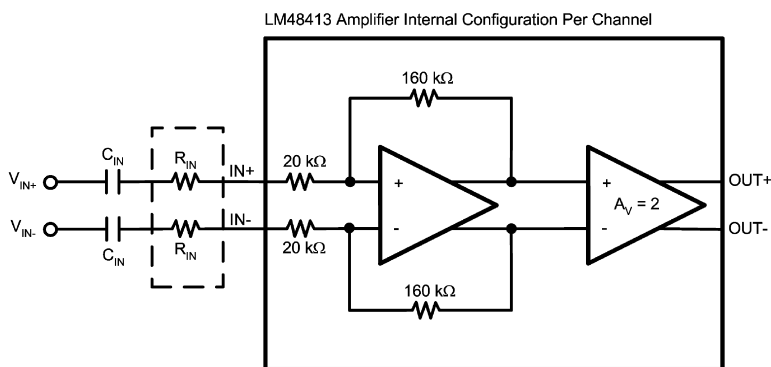

Figure 18. Audio Amplifier Gain Setting

PCB LAYOUT GUIDELINES

As output power increases, interconnect resistance (PCB traces and wires) between the amplifier, load and power supply create a voltage drop. The voltage loss due to the traces between the LM48413 and the load results in lower output power and decreased efficiency. Higher trace resistance between the supply and the LM48413 has the same effect as a poorly regulated supply, increasing ripple on the supply line, and reducing peak output power. The effects of residual trace resistance increases as output current increases due to higher output power, decreased load impedance or both. To maintain the highest output voltage swing and corresponding peak output power, the PCB traces that connect the output pins to the load and the supply pins to the power supply should be as wide as possible to minimize trace resistance.

The use of power and ground planes will give the best THD+N performance. In addition to reducing trace resistance, the use of power planes creates parasitic capacitors that help to filter the power supply line.

The inductive nature of the transducer load can also result in overshoot on one or both edges, clamped by the parasitic diodes to GND and V_{DD} in each case. From an EMI standpoint, this is an aggressive waveform that can radiate or conduct to other components in the system and cause interference. It is essential to keep the power and output traces short and well shielded if possible. Use of ground planes beads and micro-strip layout techniques are all useful in preventing unwanted interference.

As the distance from the LM48413 and the speaker increases, the amount of EMI radiation increases due to the output wires or traces acting as antennas. The EMI output spectrums of LM48413 evaluation board connected with different speaker cable lengths to an 8Ω load were measured (See [Typical Performance Characteristics](#)). Lengths from 3 inches to 12 inches are shown all fall within the limit of the FCC Class B requirement.

THD+N MEASUREMENT

Class D amplifiers, by design, switch their output power devices at a much higher frequency than the accepted audio range (20Hz – 22kHz). Alternately switching the output voltage between V_{DD} and GND allows the LM48413 to operate at much higher efficiency. However, it also increases the out-of-band noise. Since THD+N measurement is a bandwidth limited measurement, it can be significantly affected by out-of-band noise, resulting in a higher than expected THD+N measurement. To achieve a more accurate measurement of THD+N, the test equipment's input bandwidth must be limited. The input filter limits the out-of-band noise resulting in a more relevant THD+N value. A low-pass filter with a cut-off at 28kHz was used in addition to the internal filter of the THD+N measurement equipment (See [Figure 19](#)).

In real applications, the output filters are not necessary since the speakers will act as low-pass filters blocking the remaining switching noise and smoothing the output signals. Instead of connecting the LM48413's BTL outputs to speakers during measurements, the 28kHz low-pass filter is used as shown in [Figure 19](#). This measurement technique also applies to measurements such as PSRR, CMRR, and output power.

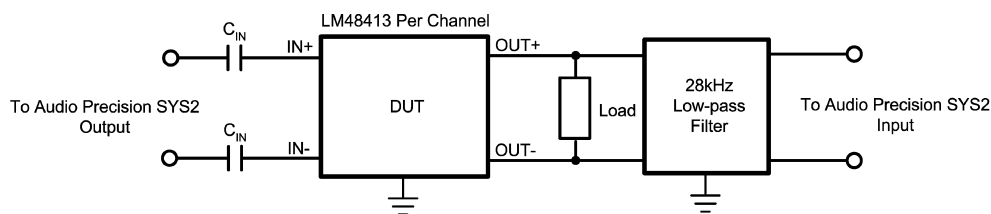
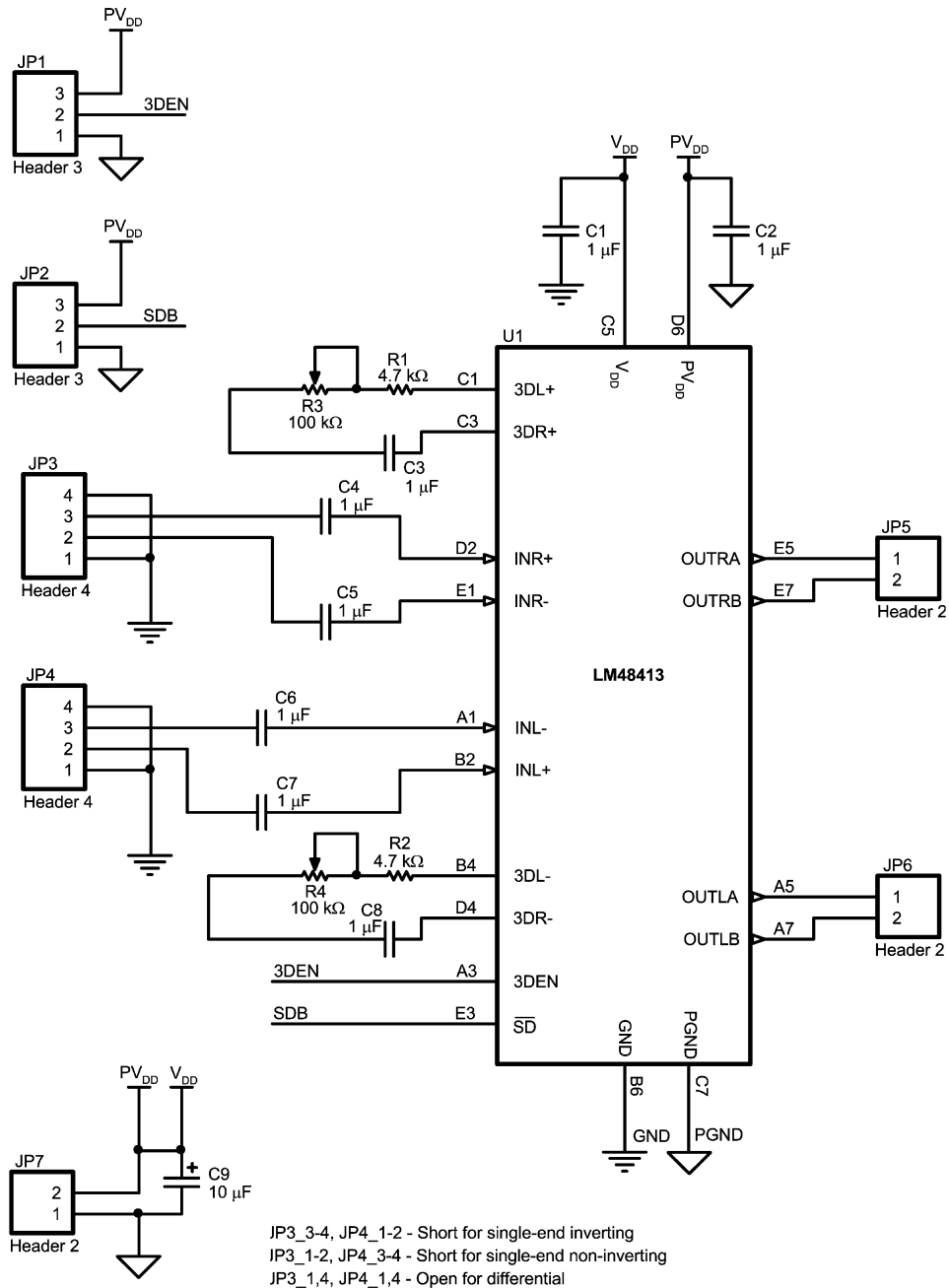

Figure 19. THD+N Measurement Test Setup

Bill Of Materials
Table 1. LM48413 Demonstration Board Bill of Materials

Item	Designator	Description	Part Number	Qty	Value	Recommended Supplier
1	U1	Stereo Class-D	LM48413TL	1		Texas Instruments
2	R1, R2	Resistor (0603)		2	4.7k Ω \pm 5%	Towa
3	C1, C2, C3, C8	Ceramic Capacitor (0603) X7R	GRM188R71C105KA01D	4	1 μ F \pm 10%, 25V	Murata
4	C4, C5, C6, C7	Ceramic Capacitor (1206) X7R	C3216X741H105K	4	1 μ F \pm 10%, 25V	TDK
5	C9	Tantium Capacitor (1210)	594D106X0025B2T	1	10 μ F \pm 10%, 25V	Vishay
6	JP5, JP6, JP7	Header 2-pin		3		
7	JP1, JP2	Header 3-pin		2		
8	JP3, JP4	Header 4-pin		2		
9	R3, R4	Potentiometer	ST-4EB100k	2	100k Ω	Copal Electronics

Demonstration Board Schematic



Demonstration Board Layout

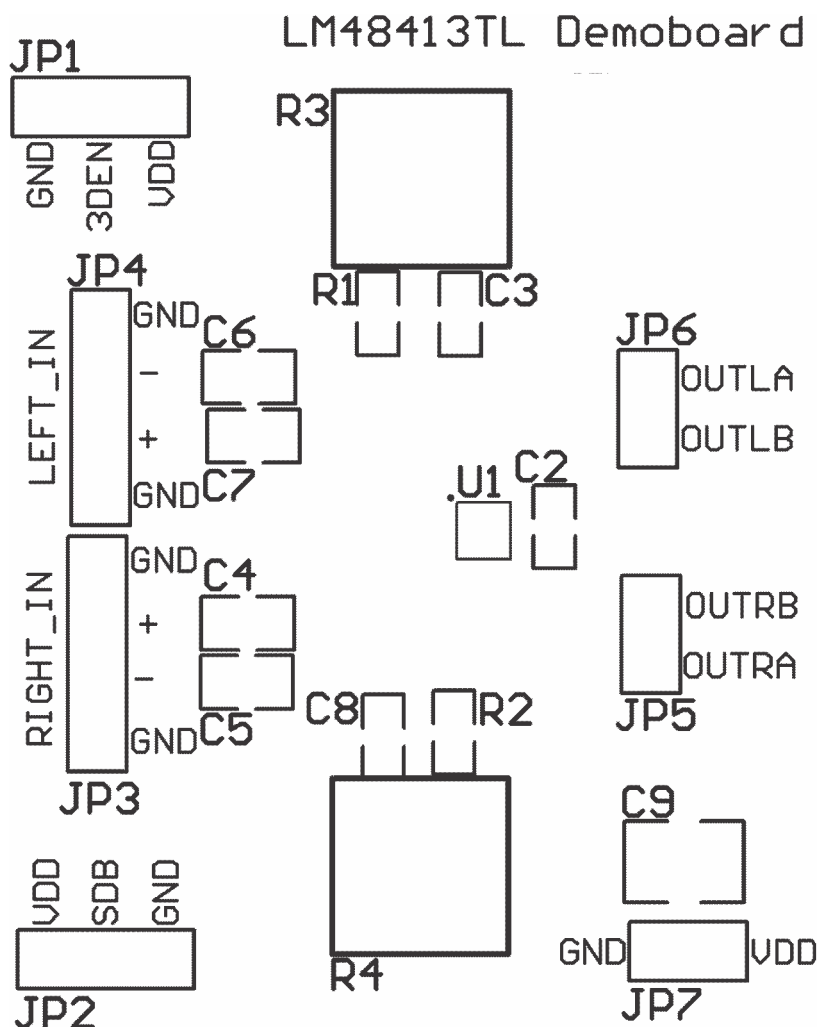

Figure 20. Top Silkscreen

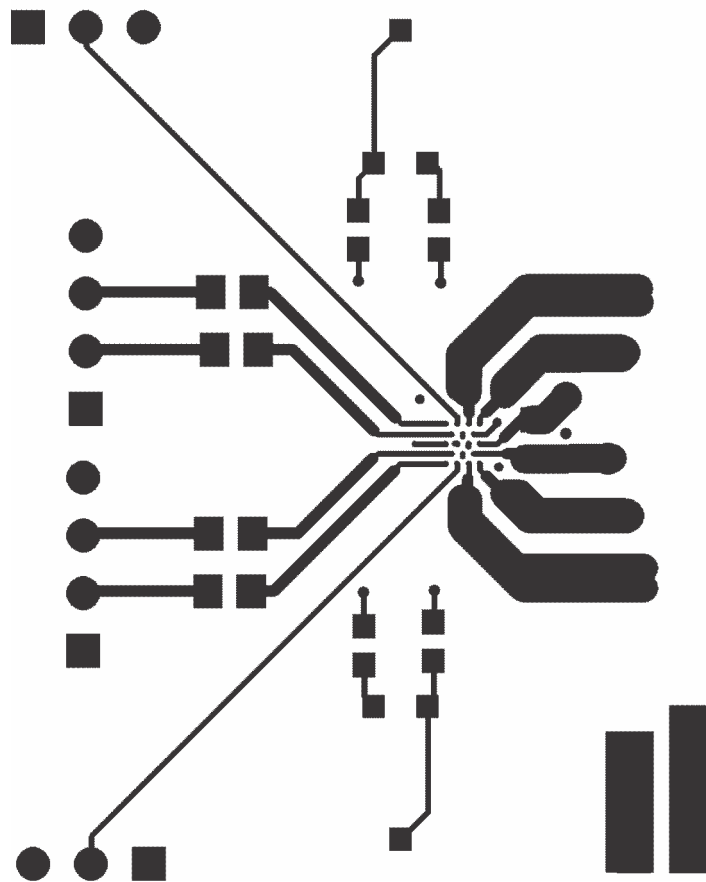

Figure 21. Top Layer

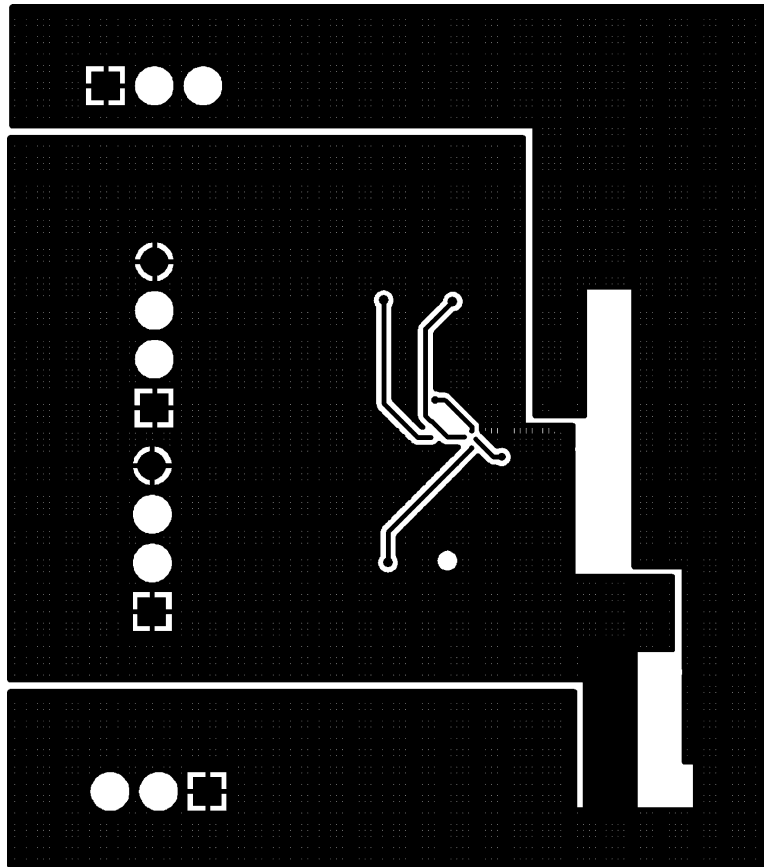

Figure 22. Middle Layer 1

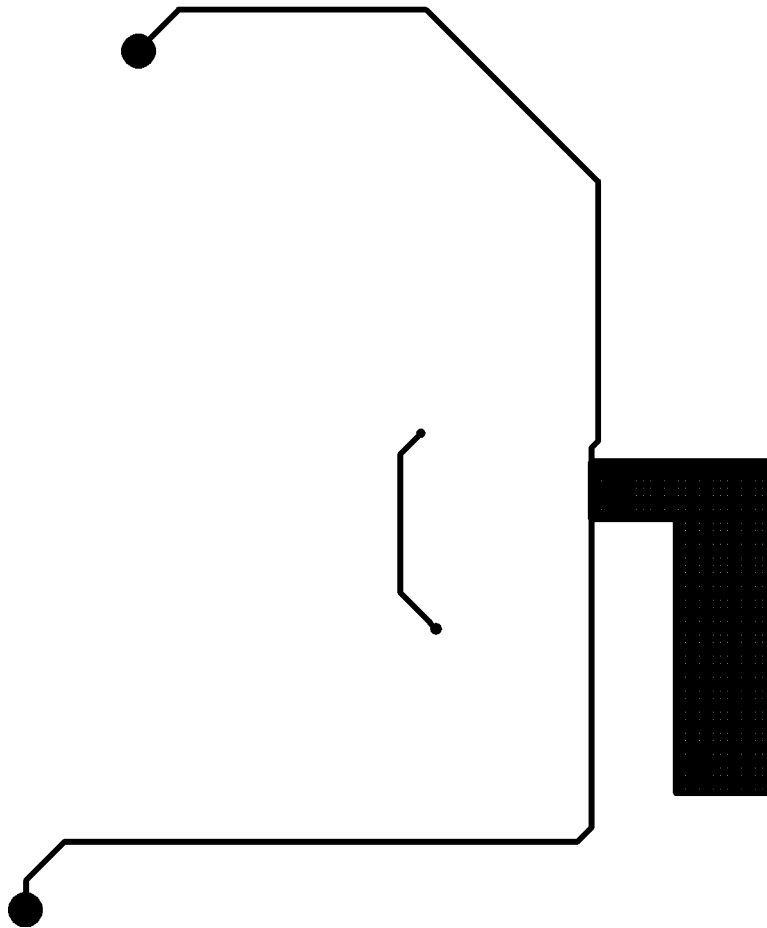

Figure 23. Middle Layer 2

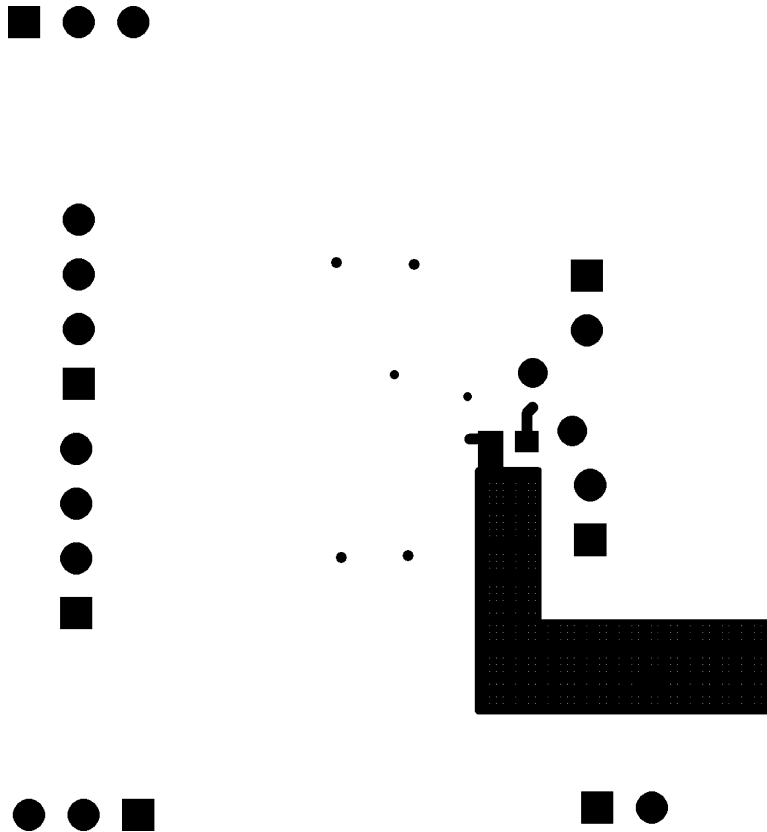

Figure 24. Bottom Layer

Revision Table

Rev	Date	Description
1.0	11/19/08	Initial release.
1.01	01/08/09	Text edits.
B	03/21/2013	Changed layout of National Data Sheet to TI format

PACKAGING INFORMATION

Orderable Device	Status (1)	Package Type	Package Drawing	Pins	Package Qty	Eco Plan (2)	Lead/Ball Finish (6)	MSL Peak Temp (3)	Op Temp (°C)	Device Marking (4/5)	Samples
LM48413TL/NOPB	ACTIVE	DSBGA	YZR	18	250	Green (RoHS & no Sb/Br)	SNAGCU	Level-1-260C-UNLIM	-40 to 85	GL2	Samples

(1) The marketing status values are defined as follows:

ACTIVE: Product device recommended for new designs.

LIFEBUY: TI has announced that the device will be discontinued, and a lifetime-buy period is in effect.

NRND: Not recommended for new designs. Device is in production to support existing customers, but TI does not recommend using this part in a new design.

PREVIEW: Device has been announced but is not in production. Samples may or may not be available.

OBSOLETE: TI has discontinued the production of the device.

(2) Eco Plan - The planned eco-friendly classification: Pb-Free (RoHS), Pb-Free (RoHS Exempt), or Green (RoHS & no Sb/Br) - please check <http://www.ti.com/productcontent> for the latest availability information and additional product content details.

TBD: The Pb-Free/Green conversion plan has not been defined.

Pb-Free (RoHS): TI's terms "Lead-Free" or "Pb-Free" mean semiconductor products that are compatible with the current RoHS requirements for all 6 substances, including the requirement that lead not exceed 0.1% by weight in homogeneous materials. Where designed to be soldered at high temperatures, TI Pb-Free products are suitable for use in specified lead-free processes.

Pb-Free (RoHS Exempt): This component has a RoHS exemption for either 1) lead-based flip-chip solder bumps used between the die and package, or 2) lead-based die adhesive used between the die and leadframe. The component is otherwise considered Pb-Free (RoHS compatible) as defined above.

Green (RoHS & no Sb/Br): TI defines "Green" to mean Pb-Free (RoHS compatible), and free of Bromine (Br) and Antimony (Sb) based flame retardants (Br or Sb do not exceed 0.1% by weight in homogeneous material)

(3) MSL, Peak Temp. - The Moisture Sensitivity Level rating according to the JEDEC industry standard classifications, and peak solder temperature.

(4) There may be additional marking, which relates to the logo, the lot trace code information, or the environmental category on the device.

(5) Multiple Device Markings will be inside parentheses. Only one Device Marking contained in parentheses and separated by a "~" will appear on a device. If a line is indented then it is a continuation of the previous line and the two combined represent the entire Device Marking for that device.

(6) Lead/Ball Finish - Orderable Devices may have multiple material finish options. Finish options are separated by a vertical ruled line. Lead/Ball Finish values may wrap to two lines if the finish value exceeds the maximum column width.

Important Information and Disclaimer: The information provided on this page represents TI's knowledge and belief as of the date that it is provided. TI bases its knowledge and belief on information provided by third parties, and makes no representation or warranty as to the accuracy of such information. Efforts are underway to better integrate information from third parties. TI has taken and continues to take reasonable steps to provide representative and accurate information but may not have conducted destructive testing or chemical analysis on incoming materials and chemicals. TI and TI suppliers consider certain information to be proprietary, and thus CAS numbers and other limited information may not be available for release.

In no event shall TI's liability arising out of such information exceed the total purchase price of the TI part(s) at issue in this document sold by TI to Customer on an annual basis.

TAPE AND REEL INFORMATION



QUADRANT ASSIGNMENTS FOR PIN 1 ORIENTATION IN TAPE



*All dimensions are nominal

Device	Package Type	Package Drawing	Pins	SPQ	Reel Diameter (mm)	Reel Width W1 (mm)	A0 (mm)	B0 (mm)	K0 (mm)	P1 (mm)	W (mm)	Pin1 Quadrant
LM48413TL/NOPB	DSBGA	YZR	18	250	178.0	8.4	2.29	2.59	0.76	4.0	8.0	Q1

TAPE AND REEL BOX DIMENSIONS



*All dimensions are nominal

Device	Package Type	Package Drawing	Pins	SPQ	Length (mm)	Width (mm)	Height (mm)
LM48413TL/NOPB	DSBGA	YZR	18	250	210.0	185.0	35.0

YZR0018

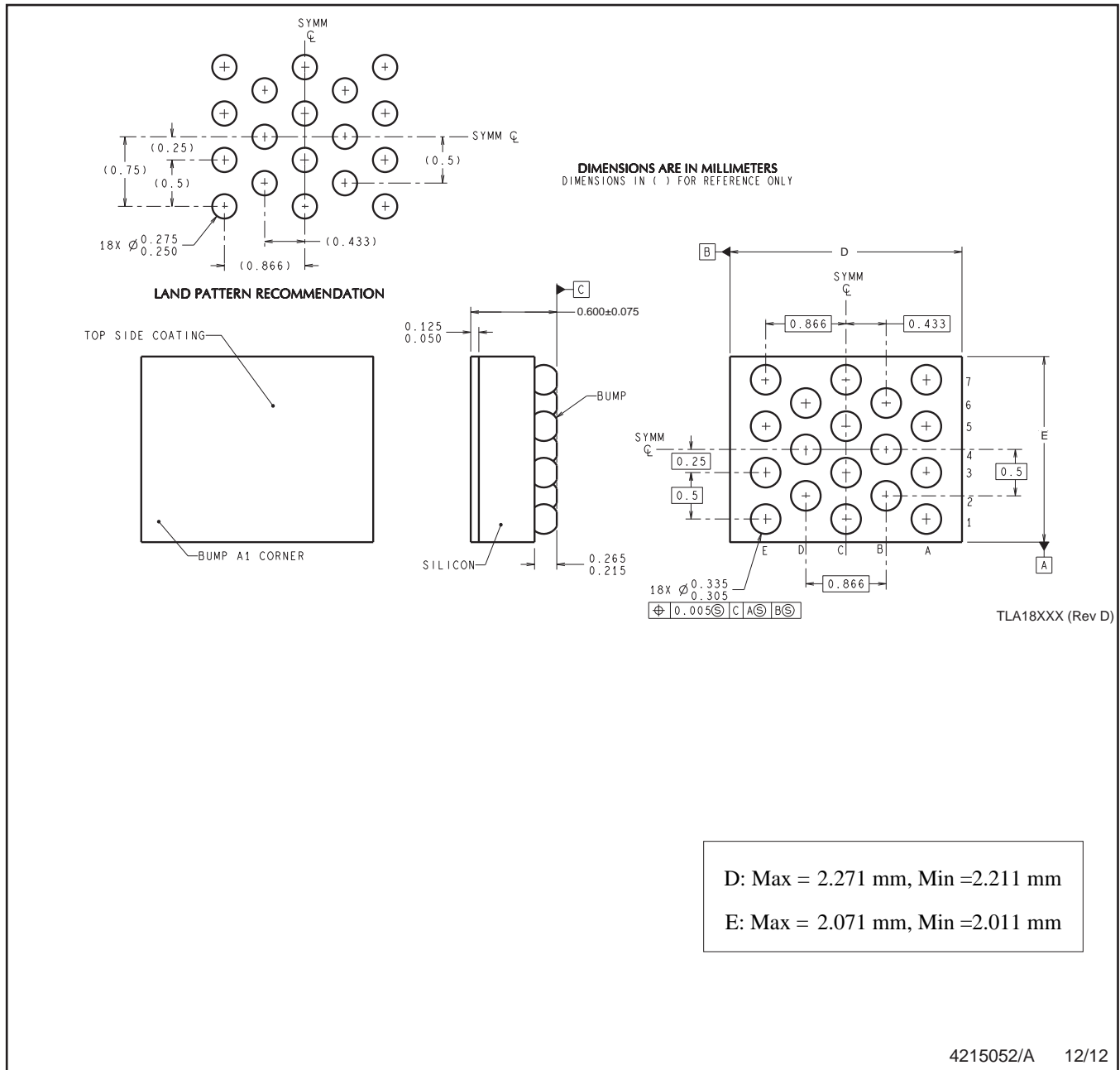

NOTES: A. All linear dimensions are in millimeters. Dimensioning and tolerancing per ASME Y14.5M-1994.
B. This drawing is subject to change without notice.

4215052/A 12/12

IMPORTANT NOTICE

Texas Instruments Incorporated (TI) reserves the right to make corrections, enhancements, improvements and other changes to its semiconductor products and services per JESD46, latest issue, and to discontinue any product or service per JESD48, latest issue. Buyers should obtain the latest relevant information before placing orders and should verify that such information is current and complete.

TI's published terms of sale for semiconductor products (<http://www.ti.com/sc/docs/stdterms.htm>) apply to the sale of packaged integrated circuit products that TI has qualified and released to market. Additional terms may apply to the use or sale of other types of TI products and services.

Reproduction of significant portions of TI information in TI data sheets is permissible only if reproduction is without alteration and is accompanied by all associated warranties, conditions, limitations, and notices. TI is not responsible or liable for such reproduced documentation. Information of third parties may be subject to additional restrictions. Resale of TI products or services with statements different from or beyond the parameters stated by TI for that product or service voids all express and any implied warranties for the associated TI product or service and is an unfair and deceptive business practice. TI is not responsible or liable for any such statements.

Buyers and others who are developing systems that incorporate TI products (collectively, "Designers") understand and agree that Designers remain responsible for using their independent analysis, evaluation and judgment in designing their applications and that Designers have full and exclusive responsibility to assure the safety of Designers' applications and compliance of their applications (and of all TI products used in or for Designers' applications) with all applicable regulations, laws and other applicable requirements. Designer represents that, with respect to their applications, Designer has all the necessary expertise to create and implement safeguards that (1) anticipate dangerous consequences of failures, (2) monitor failures and their consequences, and (3) lessen the likelihood of failures that might cause harm and take appropriate actions. Designer agrees that prior to using or distributing any applications that include TI products, Designer will thoroughly test such applications and the functionality of such TI products as used in such applications.

TI's provision of technical, application or other design advice, quality characterization, reliability data or other services or information, including, but not limited to, reference designs and materials relating to evaluation modules, (collectively, "TI Resources") are intended to assist designers who are developing applications that incorporate TI products; by downloading, accessing or using TI Resources in any way, Designer (individually or, if Designer is acting on behalf of a company, Designer's company) agrees to use any particular TI Resource solely for this purpose and subject to the terms of this Notice.

TI's provision of TI Resources does not expand or otherwise alter TI's applicable published warranties or warranty disclaimers for TI products, and no additional obligations or liabilities arise from TI providing such TI Resources. TI reserves the right to make corrections, enhancements, improvements and other changes to its TI Resources. TI has not conducted any testing other than that specifically described in the published documentation for a particular TI Resource.

Designer is authorized to use, copy and modify any individual TI Resource only in connection with the development of applications that include the TI product(s) identified in such TI Resource. NO OTHER LICENSE, EXPRESS OR IMPLIED, BY ESTOPPEL OR OTHERWISE TO ANY OTHER TI INTELLECTUAL PROPERTY RIGHT, AND NO LICENSE TO ANY TECHNOLOGY OR INTELLECTUAL PROPERTY RIGHT OF TI OR ANY THIRD PARTY IS GRANTED HEREIN, including but not limited to any patent right, copyright, mask work right, or other intellectual property right relating to any combination, machine, or process in which TI products or services are used. Information regarding or referencing third-party products or services does not constitute a license to use such products or services, or a warranty or endorsement thereof. Use of TI Resources may require a license from a third party under the patents or other intellectual property of the third party, or a license from TI under the patents or other intellectual property of TI.

TI RESOURCES ARE PROVIDED "AS IS" AND WITH ALL FAULTS. TI DISCLAIMS ALL OTHER WARRANTIES OR REPRESENTATIONS, EXPRESS OR IMPLIED, REGARDING RESOURCES OR USE THEREOF, INCLUDING BUT NOT LIMITED TO ACCURACY OR COMPLETENESS, TITLE, ANY EPIDEMIC FAILURE WARRANTY AND ANY IMPLIED WARRANTIES OF MERCHANTABILITY, FITNESS FOR A PARTICULAR PURPOSE, AND NON-INFRINGEMENT OF ANY THIRD PARTY INTELLECTUAL PROPERTY RIGHTS. TI SHALL NOT BE LIABLE FOR AND SHALL NOT DEFEND OR INDEMNIFY DESIGNER AGAINST ANY CLAIM, INCLUDING BUT NOT LIMITED TO ANY INFRINGEMENT CLAIM THAT RELATES TO OR IS BASED ON ANY COMBINATION OF PRODUCTS EVEN IF DESCRIBED IN TI RESOURCES OR OTHERWISE. IN NO EVENT SHALL TI BE LIABLE FOR ANY ACTUAL, DIRECT, SPECIAL, COLLATERAL, INDIRECT, PUNITIVE, INCIDENTAL, CONSEQUENTIAL OR EXEMPLARY DAMAGES IN CONNECTION WITH OR ARISING OUT OF TI RESOURCES OR USE THEREOF, AND REGARDLESS OF WHETHER TI HAS BEEN ADVISED OF THE POSSIBILITY OF SUCH DAMAGES.

Unless TI has explicitly designated an individual product as meeting the requirements of a particular industry standard (e.g., ISO/TS 16949 and ISO 26262), TI is not responsible for any failure to meet such industry standard requirements.

Where TI specifically promotes products as facilitating functional safety or as compliant with industry functional safety standards, such products are intended to help enable customers to design and create their own applications that meet applicable functional safety standards and requirements. Using products in an application does not by itself establish any safety features in the application. Designers must ensure compliance with safety-related requirements and standards applicable to their applications. Designer may not use any TI products in life-critical medical equipment unless authorized officers of the parties have executed a special contract specifically governing such use. Life-critical medical equipment is medical equipment where failure of such equipment would cause serious bodily injury or death (e.g., life support, pacemakers, defibrillators, heart pumps, neurostimulators, and implantables). Such equipment includes, without limitation, all medical devices identified by the U.S. Food and Drug Administration as Class III devices and equivalent classifications outside the U.S.

TI may expressly designate certain products as completing a particular qualification (e.g., Q100, Military Grade, or Enhanced Product). Designers agree that it has the necessary expertise to select the product with the appropriate qualification designation for their applications and that proper product selection is at Designers' own risk. Designers are solely responsible for compliance with all legal and regulatory requirements in connection with such selection.

Designer will fully indemnify TI and its representatives against any damages, costs, losses, and/or liabilities arising out of Designer's non-compliance with the terms and provisions of this Notice.

Looking for pricing, stock, or lifecycle information?

Click below to explore more details on WIN SOURCE:

 [View LM48413TL/NOPB on WIN SOURCE](#)

 [Texas Instruments](#) Information

Optimize Your Supply Chain with WIN SOURCE Solutions

-  Global Sourcing Solution
-  Obsolete Management
-  Cost Control Management
-  Shortage Management
-  Alternative Solution
-  Excess Inventory Management