



THE DATASHEET OF FUSB301ATMX



FUSB301A

Autonomous USB Type-C Controller with Configurable I²C Address



ON Semiconductor®

www.onsemi.com

Description

The FUSB301A is a fully autonomous Type-C controller optimized for < 15 W applications. The FUSB301A offers CC logic detection for Source Mode, Sink Mode, DRP, accessory detection support, and dead battery support. The FUSB301A features configurable I²C address to support multiple ports per system. The FUSB301A features an extremely low power disable mode as well as low power during normal operation. It is available in an ultra thin, 12-Lead TMLP Package.

Features

- Fully Autonomous Type-C Controller Supports Type-C Versions 1.1 and 1.0
- V_{DD} Operating Range, 3.0 V – 5.5 V
- Low Disable Power: I_{CC} = 2.0 μA (Max.)
- Low Standby Power: I_{CC} = 7.0 μA (Max.)
- DRP Mode with Optional Accessory Support
- Configurable I²C Address
- Capable of Supporting Try.SNK and Try.SRC
- Dead Battery Support (SINK Support when No Power Applied)
- 2 kV HBM ESD Protection
- Small Packaging, 12 Lead TMLP (1.6 mm × 1.6 mm × 0.375 mm)

Applications

- Smartphones
- Tablets
- Notebooks
- Ultra Portable Applications

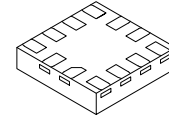

Bottom View

X2QFN12 1.6x1.6, 0.4P
CASE 722AD

ORDERING INFORMATION

See detailed ordering and shipping information on page 2 of this data sheet.

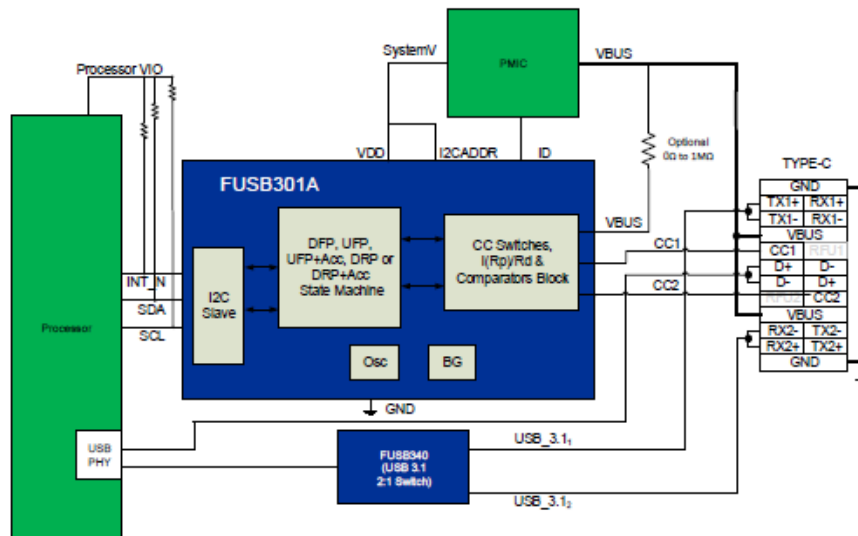

Figure 1. Typical Application

FUSB301A

ORDERING INFORMATION

Part Number	Top Mark	Operating Temperature Range	Package	Packing Method [†]
FUSB301A	NX	-40 to 85°C	12-Lead Ultra-thin Molded Leadless Package (TMLP) 1.6 mm × 1.6 mm × 0.375 mm	Tape and Reel

[†]For information on tape and reel specifications, including part orientation and tape sizes, please refer to our Tape and Reel Packaging Specifications Brochure, [BRD8011/D](#).

BLOCK DIAGRAM

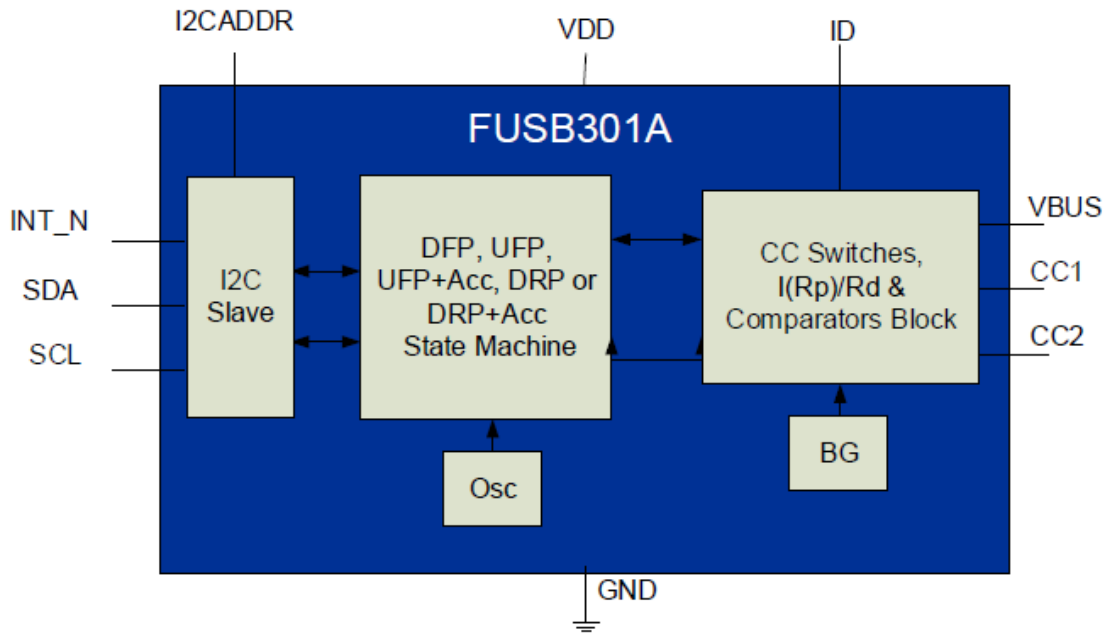

Figure 2. Block Diagram

PIN CONFIGURATION

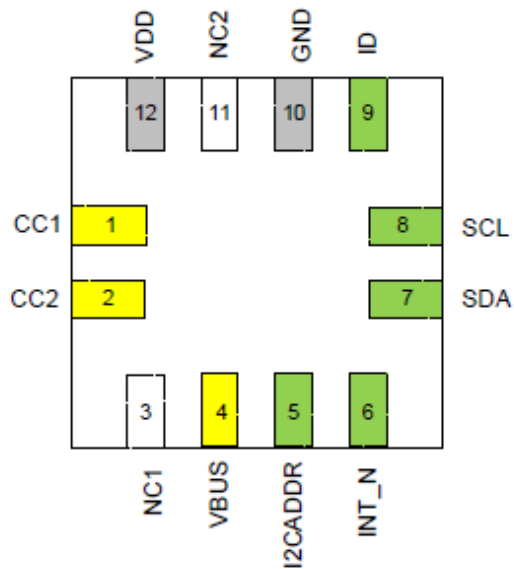

Figure 3. Pin Assignment (Top Through View)

FUSB301A

PIN DESCRIPTIONS

Pin #	Name	Type	Description
USB Type-C Connector Interface			
1, 2	CC1, CC2	I/O	Type-C Configuration Channel
4	VBUS	Input	VBUS input pin for attach and detach detection
10	GND	Ground	Ground
Power Interface			
12	VDD	Power	Input Supply Voltage
Signal Interface			
8	SCL	Input	I ² C serial clock signal to be connected to the I ² C master
7	SDA	Open-Drain I/O	I ² C serial data signal to be connected to the I ² C master
6	INT_N	Open-Drain Output	Active LOW open drain interrupt output used to prompt the processor to read the I ² C register bits
9	ID	Open-Drain Output	Used to Identify if connected device is Source or Sink. The ID Pin can be used to interface with USB 2.0 Input on the processor.
5	I2CADDR	Input	Used to change bit 3 of the I2C address so that multiple addresses can be used in a system where two device addresses conflict
3	NC1	NC	No Connect – Tie to Ground or Float
11	NC2	NC	No Connect – Tie to Ground or Float

Dead Battery

If power is not applied to FUSB301A and it is attached to a Source device, then the Source would pull up the CC line connected through the cable. The FUSB301A in response would turn on the pull-down that will bring the CC voltage to a range that the Source can detect an attach and turn on VBUS.

Power Up, Initialization and Reset, Interrupt Operation

When power is first applied, the FUSB301A will power up in Sink mode with all interrupts masked. The local processor must configure the FUSB301A to the desired mode and clear the global interrupt mask bit, INT_MASK. The INT_N pin is an active low, open drain output. This pin indicates to the host processor that an interrupt has occurred in the FUSB301A which needs attention. The INT_N pin is

in a high impedance state by default after power-up or device reset, and the global interrupt mask (INT_MASK in Control register) is set. After INT_MASK bit is cleared by the local processor, the INT_N pin stays high impedance in preparation of future interrupts. When an interruptible event occurs, INT_N is driven LOW and is in a high impedance state again when the processor clears the interrupt by reading the interrupt registers. Subsequent to the initial power up or reset; if the processor writes a “1” to global interrupt mask bit when the system is already powered up, the INT_N pin stays in a high impedance state and ignores all interrupts until the global interrupt mask bit is cleared. If an event happens that would ordinarily cause an interrupt when the global interrupt mask bit is set, the INT_N pin goes LOW when the global interrupt mask is cleared.

Table 1. ID PIN TRUTH TABLE

Type Register (h12, bit 4)	Description	ID
SINK = b0	SINK Not Detected	Hi-Z (default)
SINK = b1	SINK Detected	Low

ABSOLUTE MAXIMUM RATINGS

Symbol	Parameter	Min.	Max.	Unit
V _{DD}	Supply Voltage from V _{DD}	-0.5	6.0	V
V _{BUS}	VBUS Supply Voltage	-0.5	28	V
V _{CC_HDDRP}	CC pins when configured as Host, Device or Dual Role Port	-0.5	6.0	V
T _{STORAGE}	Storage Temperature Range	-65	+150	°C

FUSB301A

ABSOLUTE MAXIMUM RATINGS (continued)

Symbol	Parameter		Min.	Max.	Unit
T _J	Maximum Junction Temperature			+150	°C
T _L	Lead Temperature (Soldering, 10 seconds)			+260	°C
ESD	IEC 6100-4-2 System ESD	Connector Pins (VBUS, CC1 and CC2)	Air Gap	15	kV
			Contact	8	
	Human Body Model, JEDEC JESD22-A114	Connector Pins (VBUS, CC1 and CC2)		4	
		Others		2	
Charged Device Model, JEDEC LESD22-C101	All Pins		1		

Stresses exceeding those listed in the Maximum Ratings table may damage the device. If any of these limits are exceeded, device functionality should not be assumed, damage may occur and reliability may be affected.

RECOMMENDED OPERAING CONDITIONS

Symbol	Parameter	Min.	Typ.	Max.	Unit
V _{BUS}	VBUS Supply Voltage	3.7	5.0	21	V
V _{DD}	Supply Voltage	2.8 ⁽¹⁾	3.3	5.5	V
T _A	Operating Temperature	-40		+85	°C

1. This is for functional operation only and isn't the lowest limit for all subsequent electrical specifications below. All electrical parameters have a minimum of 3 V operation.

DC AND TRANSIENT CHARACTERISTICS

Unless otherwise specified: Recommended T_A and T_J temperature ranges. All typical values are at T_A = 25°C and V_{DD} = 3.3 V unless otherwise specified.

Symbol	Parameter	T _A = -40 to +85°C T _J = -40 to +125°C			Unit
		Min.	Typ.	Max.	
Type C Specific Parameters					
I _{80_CCX}	Source 80 μA CC Current (Default) HOST_CUR1 = 0, HOST_CUR0 = 1	64	80	96	μA
I _{180_CCX}	Source 180 μA CC Current (1.5 A) HOST_CUR1 = 1, HOST_CUR0 = 0	166	180	194	μA
I _{330_CCX}	Source 330 μA CC Current (3 A) HOST_CUR1 = 1, HOST_CUR0 = 1	304	330	356	μA
V _{SNKDB}	Sink Pull-Down Voltage in Dead Battery Under all Pull-up SOURCE Loads			2.18	V
R _{DEVICE}	Sink Pull-Down Resistance when V _{DD} is within Operating Range	4.6	5.1	5.6	kΩ
z _{OPEN}	CC Resistance for Disabled State	126			kΩ
v _{Ra-SRCdef}	Ra Detection Threshold for CC Pin for Source for Default Current on VBUS	0.15	0.20	0.25	V
v _{Ra-SRC1.5A}	Ra Detection Threshold for CC Pin for Source for 1.5 A Current on VBUS	0.35	0.40	0.45	V
v _{Ra-SRC3A}	Ra Detection Threshold for CC Pin for Source for 3 A Current on VBUS	0.75	0.80	0.85	V
v _{Rd-SRCdef}	Rd Detection Threshold for Source for Default Current (HOST_CUR1/0 = 01)	1.50	1.60	1.65	V
v _{Rd-SRC1.5A}	Rd Detection Threshold for Source for 1.5 A Current (HOST_CUR1/0 = 10)	1.50	1.60	1.65	V

FUSB301A

DC AND TRANSIENT CHARACTERISTICS

Unless otherwise specified: Recommended T_A and T_J temperature ranges. All typical values are at $T_A = 25^\circ\text{C}$ and $V_{DD} = 3.3\text{ V}$ unless otherwise specified. (continued)

Symbol	Parameter	$T_A = -40\text{ to }+85^\circ\text{C}$ $T_J = -40\text{ to }+125^\circ\text{C}$			Unit
		Min.	Typ.	Max.	
vRd-SRC3A	Rd Detection Threshold for Source for 3 A Current (HOST_CUR1/0 = 11)	2.45	2.60	2.75	V
vRa-SNK	Ra Detection Threshold for CC Pin for Sink	0.15	0.20	0.25	V
vRd-def	Rd Default Current Detection Threshold for Sink	0.61	0.66	0.70	V
vRd-1.5A	Rd 1.5 A Current Detection Threshold for Sink	1.16	1.23	1.31	V
vRd-3.0A	Rd 3 A Current Detection Threshold for Sink	2.04	2.11	2.18	V
vVBUSthr	VBUS Threshold at which I_VBUSOK Interrupt is Triggered			3.7	V

CURRENT CONSUMPTION

Symbol	Parameter	V_{DD} (V)	Conditions	$T_A = -40\text{ to }+85^\circ\text{C}$ $T_J = -40\text{ to }+125^\circ\text{C}$			Unit
				Min.	Typ.	Max.	Unit
Idisable	Disabled Current	3.0 to 5.5	Disabled State		0.35	2.0	μA
Istby	Unattached Sink	3.0 to 5.5	Nothing attached		3.5	7.0	μA
	Unattached Sink + Acc, Source + Acc, or DRP		Nothing attached, Internally Toggling		5	20	μA
Iattach	Attach Current (Less Host Current)	3.0 to 5.5	Attached as a Sink		5	15	μA
			Attached as a Source		10	15	μA

TIMING PARAMETERS

Symbol	Parameter	$T_A = -40\text{ to }+85^\circ\text{C}$ $T_J = -40\text{ to }+125^\circ\text{C}$			Unit
		Min.	Typ.	Max.	Unit
tCCDebounce	Debounce Time for CC (Source or Accessory)	100	150	200	ms
	Debounce Time for CC (Sink)	63	75	87	ms
tPDDebounce	Debounce Time for CC Detach Detection	10	15	20	ms
tAccDetect	Debounce Time to Detect AudioAccessory, or DebugAccessory is Attached	50	100	200	ms
tErrorRecovery	Time staying in the ErrorRecovery State if sent there via the ERROR_REC bit or by a change of Modes	25	50	100	ms
tVBUSondeb	Debounce Time of VBUS Detection when acting as a Sink to Signal VBUS is present	0.167	0.200	0.375	ms
tVBUSoffdeb	Debounce Time of VBUS Detection when acting as a Sink to Signal VBUS has been removed	10	15	20	ms
tDRPToggle1	For DRP Operation, Time Spent in Unattached.Sink before going to Unattached.Source State	DRPROGGLE = 00	35	70	ms
		DRPROGGLE = 01	30	60	
		DRPROGGLE = 10	25	50	
		DRPROGGLE = 11	20	40	

FUSB301A

TIMING PARAMETERS

Symbol	Parameter	T _A = -40 to +85°C T _J = -40 to +125°C			Unit	
		Min.	Typ.	Max.	Unit	
tDRPToggle2	For DRP Operation, Time Spent in Unattached.Source before going to Unattached.Sink State	DRPROGGLE = 00	15		30	ms
		DRPROGGLE = 01	20		40	
		DRPROGGLE = 10	25		50	
		DRPROGGLE = 11	30		60	

IO SPECIFICATIONS

Symbol	Parameter	V _{DD} (V)	Conditions	T _A = -40 to +85°C T _J = -40 to +125°C			Unit
				Min.	Typ.	Max.	Unit
Host Interface Pins (ID)							
V _{OLID}	Output Low Voltage	3.0 to 5.5	I _{OL} = 4 mA			0.4	V
Host Interface Pins (I2CADDR)							
V _{ILADDR}	Low-Level Input Voltage	3.0 to 5.5				0.3V _{DD}	V
V _{IHADDR}	High-Level Input Voltage	3.0 to 5.5		0.7V _{DD}			V
Host Interface Pins (INT_N)							
V _{OLINTN}	Output Low Voltage	3.0 to 5.5	I _{OL} = 4 mA			0.4	V
I²C Interface Pins – Fast Mode SDA, SCL							
V _{ILI2C}	Low-Level Input Voltage	3.0 to 5.5				0.4	V
V _{IHI2C}	High-Level Input Voltage	3.0 to 5.5		1.2			V
V _{HYS}	Hysteresis of Schmitt Trigger Inputs	3.0 to 5.5		0.2			V
I _{I2C}	Input Current of SDA and SCL Pins	3.0 to 5.5	Input Voltage 0.26 V to 2 V	-10		10	μA
I _{CCTI2C}	VDD Current when SDA and SCL are HIGH	3.0 to 5.5	Input Voltage 1.8 V			10	μA
V _{OLSDA}	Low-Level Output Voltage at 3 mA Sink Current (Open-Drain)	3.0 to 5.5		0		0.3	V
C _I	Capacitance for Each I/O Pin ⁽²⁾	3.0 to 5.5				10	pF

2. Guaranteed by characterization. Not production tested.

FAST MODE I²C SPECIFICATIONS (Note 3)(see Figure 4)

Symbol	Parameter	Fast Mode		Unit
		Min.	Max.	
f _{SCL}	I2C_SCL Clock Frequency	0	400	kHz
t _{HD;STA}	Hold Time (Repeated) START Condition	0.6		μs
t _{LOW}	LOW Period of I2C_SCL Clock	1.3		μs
t _{HIGH}	HIGH Period of I2C_SCL Clock	0.6		μs
t _{SU;STA}	Set-up Time for Repeated START Condition	0.6		μs
t _{HD;DAT}	Data Hold Time	0	0.9	μs
t _{SU;DAT}	Data Set-up Time (Note 4)	100		ns
t _r	Rise Time of I2C_SDA and I2C_SCL Signals (Note 5)	20*(V _{DD} /5.5V)	250	ns
t _f	Fall Time of I2C_SDA and I2C_SCL Signals (Note 5)	20*(V _{DD} /5.5V)	250	ns

FUSB301A

FAST MODE I²C SPECIFICATIONS (Note 3)(see Figure 4) (continued)

Symbol	Parameter	Fast Mode		Unit
		Min.	Max.	
t _{SU;STO}	Set-up Time for STOP Condition	0.6		μs
t _{BUF}	BUS-Free Time between STOP and START Conditions	1.3		μs
t _{SP}	Pulse Width of Spikes that Must Be Suppressed by the Input Filter	0	50	ns

- Guaranteed by characterization. Not production tested.
- A fast-mode I²C bus device can be used in a standard-mode I²C bus system, but the requirement t_{SU;DAT} ≥ 250 ns must be met. This is automatically the case of the device does not stretch the LOW period of the I²C_SCL signal. If such a device does stretch the LOW period I²C_SCL signal, it must output the next data bit to the I²C_SDA line t_{r_max} + t_{SU;DAT} = 1000 + 250 = 1250 ns (according to the standard-mode I²C bus specification) before the I²C_SCL line is released.
- C_b equals the total capacitance of one bus line in pF. If mixed with high-speed devices, faster fall times are allowed according to the I²C specification.

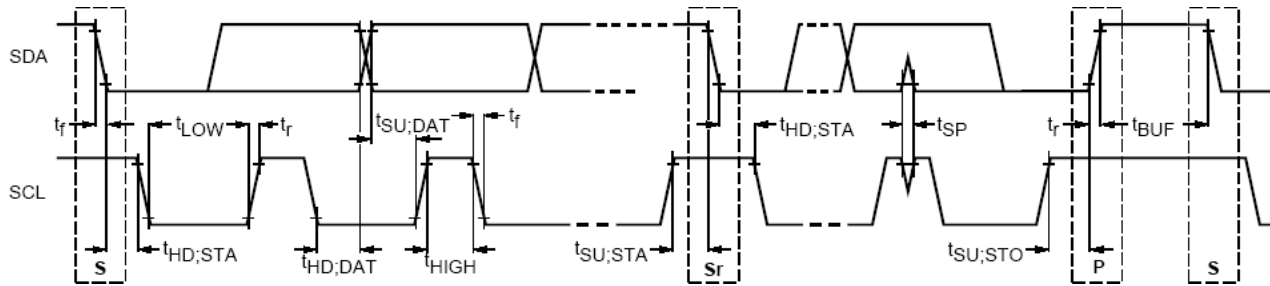
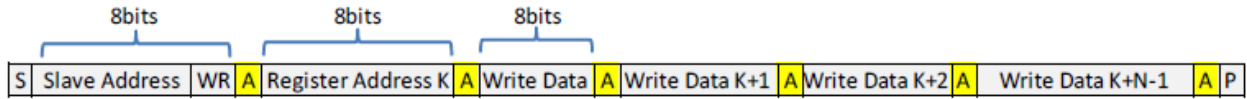

Figure 4. Definition of Timing for Full-Speed Mode Devices on the I²C Bus

I²C INTERFACE

The FUSB301A includes a full I²C slave controller. The I²C slave fully complies with the I²C specification version 6

requirements. This block is designed for fast mode. Examples of an I²C write and read sequence are shown Figure 5 and Figure 6 respectively.



NOTE: Single Byte read is initiated by Master with P immediately following first data byte.

Figure 5. I²C Write Example

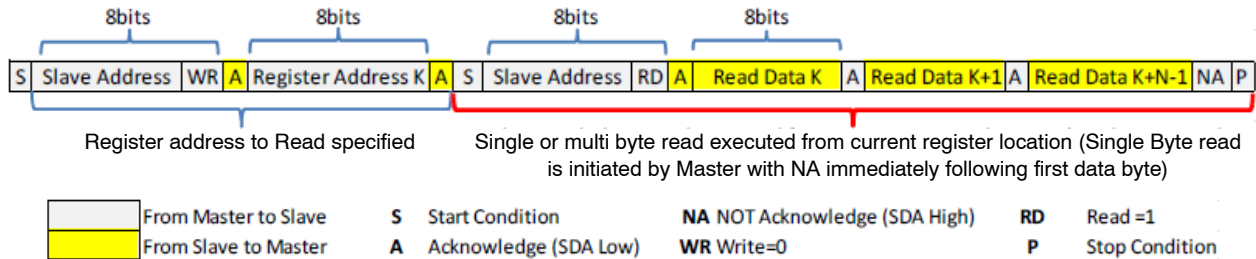

NOTE: If Register is not specified Master will begin read from current register. In this case only sequence showing in Red bracket is needed.

Figure 6. I²C Read Example

I²C ADDRESS

The I2CADDR bit high or low is indicated in bit3 of the slave address shown in Table 2.

FUSB301A

Table 2. FUSB301A I²C SLAVE ADDRESS

Name	Size (Bits)	Bit 7	Bit 6	Bit 5	Bit 4	Bit 3	Bit 2	Bit 1	Bit 0
Slave Address	8	0	1	0	0	I2CADDR	0	1	R/W

REGISTER DEFINITIONS

Table 3. REGISTER MAP

Address	Register Name	Type	RST Val	Bit 7	Bit 6	Bit 5	Bit 4	Bit 3	Bit 2	Bit 1	Bit 0
0x01	Device ID	RO	12	Version ID [3:0]				Revision ID [3:0]			
0x02	Modes	R/W	04			DRP+ACC	DRP	Sink+ACC	Sink	Source+ACC	Source
0x03	Control	R/W	03	DRPTOGGLE					HOST_CUR1	HOST_CUR0	INT_MASK
0x04	Manual	W/C	00					UNATT_SNK	UNATT_SRC	DISABLED	ERROR_REC
0x05	Reset	W/C	00								SW_RES
0x06–0x0F	Reserved	X	xx	Do Not Use							
0x10	Mask	R/W	00					M_ACC_CH	M_BC_LVL	M_DETACH	M_ATTACH
0x11	Status	RO	00			ORIENT1	ORIENT0	VBUSOK	BC_LVL1	BC_LVL0	ATTACH
0x12	Type	RO	00				Sink	Source		DEBUGACC	AUDIOACC
0x13	Interrupt	R/C	00					I_ACC_CH	I_BC_LVL	I_DETACH	I_ATTACH
0x14–0x1F	Reserved	X	xx	Do Not Use							

6. Do not use registers that are blank.

7. Values read from undefined register bits are invalid. Do not write to undefined registers.

Table 4. DEVICE ID

Address: 01h

Reset Value: 0x0001_0010

Type: Read Only

Bit #	Name	Size (Bits)	Description
7:4	Version ID	4	Device version ID by Trim or etc. A_[Version ID]: 0001 (FUSB301ATMX)
3:0	Revision ID	4	Revision History of each version [Revision ID]_revC: 0010

Table 5. MODES

Address: 02h

Reset Value: 0x0000_0100

Type: Read/Write

Bit #	Name	Size (Bits)	Description
7:6	Reserved	2	Do Not Use
5	DRP+ACC	1	1: Configure device as a Dual Role Port (DRP) with accessory support
4	DRP	1	1: Configure device as a Dual Role Port (DRP) without accessory support
3	Sink+ACC	1	1: Configure device as a Sink with accessory support
2	Sink	1	1: Configure device as a Sink without accessory support
1	Source+ACC	1	1: Configure device as a Source with accessory support
0	Source	1	1: Configure device as a Source without accessory support

FUSB301A

Table 6. CONTROL

Address: 03h
 Reset Value: 0×XX00_X011
 Type: Read/Write

Bit #	Name	Size (Bits)	Description
7:6	Reserved	2	Do Not Use
5:4	DRPTOGGLE	2	Selects different timing for Dual Role Port Toggle between Unattached. Sink State and Unattached.SOURCE State. 00: 35 ms min. in Unattached.Sink and 15 ms min. In Unattached.-SOURCE 01: 30 ms min. In Unattached.Sink and 20 ms min. In Unattached.SOURCE 10: 25 ms min. In Unattached.Sink and 25 ms min. In Unattached.SOURCE 11: 20 ms min. In Unattached.Sink and 30 ms min. In Unattached.SOURCE
3	Reserved	1	Do Not Use
2:1	HOST_CUR [1:0]	2	1: Controls the pull-up current when device enabled as a Source 00: No Current 01: 80 μA – Default USB Power 10: 180 μ A – Medium Current Mode: 1.5 A 11: 330 μ A – High Current Mode: 3 A
0	INT_MASK	1	1: Global interrupt mask to mask all interrupts

Table 7. MANUAL(Note 8)

Address: 04h
 Reset Value: 0×XXXX_0000
 Type: Write/Clear

Bit #	Name	Size (Bits)	Description
7:4	Reserved	4	Do Not Use
3	UNATT_SINK (Note 9)	1	1: Put device in Unattached.Sink state as defined in the Type C spec
2	UNATT_SOURCE	1	1: Put device in Unattached.Source state as defined in the Type C spec
1	DISABLED (Note 10)	1	1: Put device in Disabled state as defined in the Type C spec
0	ERROR_REC	1	1: Put device in ErrorRecovery state as defined in the Type C spec

8. If more than one bit is set to “b1” simultaneously then an order of priority will be used. 1st priority is DISABLED, 2nd is ERROR_REC, 3rd is UNATT_SOURCE, last is UNATT_SINK. The highest priority bit will take precedence and all other bits will be cleared automatically.
 9. Wait 2 ms between Modes = Sink and Manual = UNATT_SINK writes.
 10. The DISABLED bit must be manually cleared.

Table 8. RESET

Address: 05h
 Reset Value: 0×XXXX_XXX0
 Type: Write/Clear

Bit #	Name	Size (Bits)	Description
7:6	Reserved	7	Do Not Use
0	SW_RES	1	1: Reset the system and I2C Register.

Table 9. MASK

Address: 10h
 Reset Value: 0×XXXX_0000
 Type: Read/Write

Bit #	Name	Size (Bits)	Description
7:4	Reserved	4	Do Not Use
3	M_ACC_CH	1	1: Mask a change from Accessory Present to Attached Accessory

FUSB301A

Table 9. MASK (continued)

Address: 10h

Reset Value: 0×XXXX_0000

Type: Read/Write

Bit #	Name	Size (Bits)	Description
2	M_BC_LVL	1	1: Mask a change in I_BC_LVL interrupt bit
1	M_DETACH	1	1: Mask the I_DETACH interrupt bit
0	M_ATTACH	1	1: Mask a change in the I_ATTACH interrupt bit

Table 10. STATUS

Address: 11h

Reset Value: 0×XX00_0000

Type: Read

Bit #	Name	Size (Bits)	Description
7:6	Reserved	2	Do Not Use
5:4	ORIENT[1:0]	2	Status to indicate which CCx pins has the CC cable connection 11: A fault has occurred during the detection 10: Cable CC is connected through the CC2 pin 01: Cable CC is connected through the CC1 pin 00: No or unresolved connection detected.
3	VBUSOK	1	1: Status to indicate VBUS is in the valid range
2:1	BC_LVL[1:0]	2	Thresholds that allow detection of current advertisement on CC line 00: Ra or unattached Sink 01: Rd threshold for Sink default current advertisement 10: RD threshold for Sink 1.5 A current advertisement 11: RD threshold for Sink 3 A current advertisement
0	ATTACH	1	1: Attached to a device or accessory of a type shown in the Type register

Table 11. TYPE

Address: 12h

Reset Value: 0×XXX0_0X00

Type: Read

Bit #	Name	Size (Bits)	Description
7:5	Reserved	3	Do Not Use
4	Sink	1	1: Indicates a Sink has been detected
3	Source	1	1: Indicates a Source has been detected
2	Reserved	1	Do Not Use
1	DEBUGACC	1	1: Indicates a Debug Accessory has been detected
0	AUDIOACC	1	1: Indicates a Audio Accessory has been detected

Table 12. INTERRUPT0

Address: 13h

Reset Value: 0×XXXX_X000

Type: Write/Clear

Bit #	Name	Size (Bits)	Description
7:4	Reserved	4	Do Not Use
3	I_ACC_CH	1	1: Interrupt flagged when a change from Accessory Present to Audio Accessory or Debug Accessory occurs.
2	I_BC_LVL	1	1: Interrupt flagged when a change in BC_LVL advertised current level has occurred

FUSB301A

Table 12. INTERRUPT0 (continued)

Address: 13h

Reset Value: 0×XXXX_X000

Type: Write/Clear

Bit #	Name	Size (Bits)	Description
1	I_DETACH	1	1: Interrupt flagged when a device or accessory has been detached
0	I_ATTACH	1	1: Interrupt flagged when a device or accessory of type indicated in the Type register has been attached

X2QFN12 1.6x1.6, 0.4P
CASE 722AD
ISSUE O

DATE 31 OCT 2016

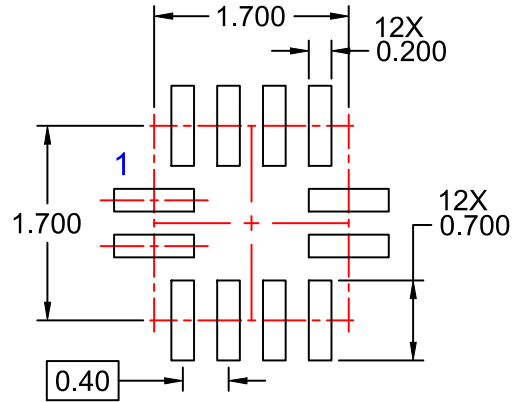
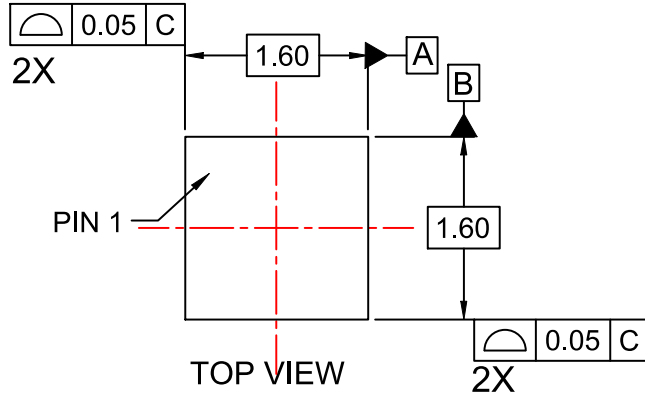

LAND PATTERN RECOMMENDATION

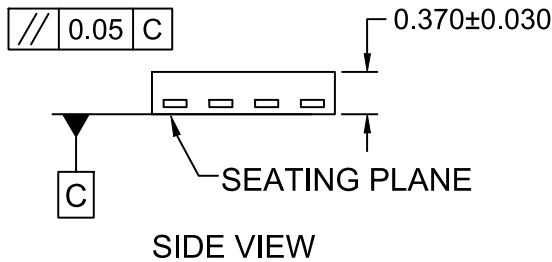

SIDE VIEW

NOTES:

- A. NO JEDEC REGISTRATION APPLIES.
- B. DIMENSIONS ARE IN MILLIMETERS.
- C. DIMENSIONS AND TOLERANCE PER ASME Y14.5M, 2009.
- D. PACKAGE NOMINAL HEIGHT IS 370 MICRONS.

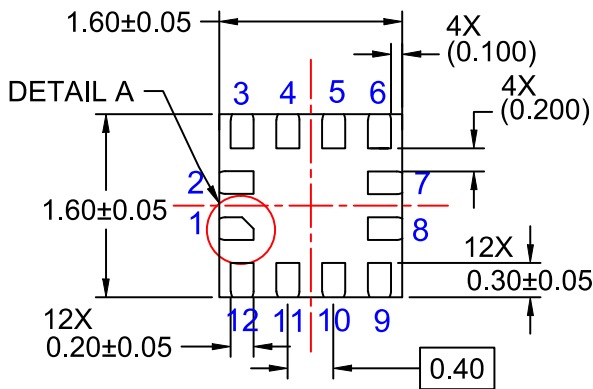
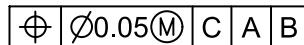

BOTTOM VIEW

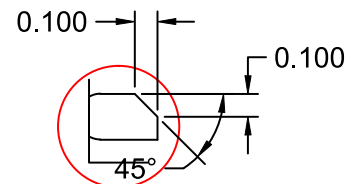

DETAIL A 2X

DOCUMENT NUMBER:	98AON13693G	Electronic versions are uncontrolled except when accessed directly from the Document Repository. Printed versions are uncontrolled except when stamped "CONTROLLED COPY" in red.
STATUS:	ON SEMICONDUCTOR STANDARD	
NEW STANDARD:		
DESCRIPTION:	X2QFN12 1.6x1.6, 0.4P	PAGE 1 OF 2

ON Semiconductor and  are trademarks of Semiconductor Components Industries, LLC dba ON Semiconductor or its subsidiaries in the United States and/or other countries. ON Semiconductor owns the rights to a number of patents, trademarks, copyrights, trade secrets, and other intellectual property. A listing of ON Semiconductor's product/patent coverage may be accessed at www.onsemi.com/site/pdf/Patent-Marking.pdf. ON Semiconductor reserves the right to make changes without further notice to any products herein. ON Semiconductor makes no warranty, representation or guarantee regarding the suitability of its products for any particular purpose, nor does ON Semiconductor assume any liability arising out of the application or use of any product or circuit, and specifically disclaims any and all liability, including without limitation special, consequential or incidental damages. Buyer is responsible for its products and applications using ON Semiconductor products, including compliance with all laws, regulations and safety requirements or standards, regardless of any support or applications information provided by ON Semiconductor. "Typical" parameters which may be provided in ON Semiconductor data sheets and/or specifications can and do vary in different applications and actual performance may vary over time. All operating parameters, including "Typicals" must be validated for each customer application by customer's technical experts. ON Semiconductor does not convey any license under its patent rights nor the rights of others. ON Semiconductor products are not designed, intended, or authorized for use as a critical component in life support systems or any FDA Class 3 medical devices or medical devices with a same or similar classification in a foreign jurisdiction or any devices intended for implantation in the human body. Should Buyer purchase or use ON Semiconductor products for any such unintended or unauthorized application, Buyer shall indemnify and hold ON Semiconductor and its officers, employees, subsidiaries, affiliates, and distributors harmless against all claims, costs, damages, and expenses, and reasonable attorney fees arising out of, directly or indirectly, any claim of personal injury or death associated with such unintended or unauthorized use, even if such claim alleges that ON Semiconductor was negligent regarding the design or manufacture of the part. ON Semiconductor is an Equal Opportunity/Affirmative Action Employer. This literature is subject to all applicable copyright laws and is not for resale in any manner.

PUBLICATION ORDERING INFORMATION

LITERATURE FULFILLMENT:

Literature Distribution Center for ON Semiconductor
19521 E. 32nd Pkwy, Aurora, Colorado 80011 USA
Phone: 303-675-2175 or 800-344-3860 Toll Free USA/Canada
Fax: 303-675-2176 or 800-344-3867 Toll Free USA/Canada
Email: orderlit@onsemi.com

N. American Technical Support: 800-282-9855 Toll Free
USA/Canada
Europe, Middle East and Africa Technical Support:
Phone: 421 33 790 2910

ON Semiconductor Website: www.onsemi.com

Order Literature: <http://www.onsemi.com/orderlit>

For additional information, please contact your local
Sales Representative

Looking for pricing, stock, or lifecycle information?

Click below to explore more details on WIN SOURCE:

-  [View FUSB301ATMX on WIN SOURCE](#)
-  [Fairchild/ON Semiconductor Information](#)

Optimize Your Supply Chain with WIN SOURCE Solutions

-  Global Sourcing Solution
-  Obsolete Management
-  Cost Control Management
-  Shortage Management
-  Alternative Solution
-  Excess Inventory Management