



THE DATASHEET OF CY29FCT520CTSOC



CY29FCT520T MULTILEVEL PIPELINE REGISTER WITH 3-STATE OUTPUTS

SCCS011C – MAY 1994 – REVISED NOVEMBER 2001

- **Function, Pinout, and Drive Compatible With FCT, F Logic, and AM29520**
- **Reduced V_{OH} (Typically = 3.3 V) Version of Equivalent FCT Functions**
- **Edge-Rate Control Circuitry for Significantly Improved Noise Characteristics**
- **I_{off} Supports Partial-Power-Down Mode Operation**
- **Matched Rise and Fall Times**
- **Fully Compatible With TTL Input and Output Logic Levels**
- **ESD Protection Exceeds JESD 22**
 - 2000-V Human-Body Model (A114-A)
 - 200-V Machine Model (A115-A)
 - 1000-V Charged-Device Model (C101)
- **Single- and Dual-Pipeline Operation Modes**
- **Multiplexed Data Inputs and Outputs**
- **CY29FCT520T**
 - 64-mA Output Sink Current
 - 32-mA Output Source Current
- **CY29FCT520ATDMB, CY29FCT520BTDMB**
 - 32-mA Output Sink Current
 - 12-mA Output Source Current
- **3-State Outputs**

**D, P, OR SO PACKAGE
(TOP VIEW)**

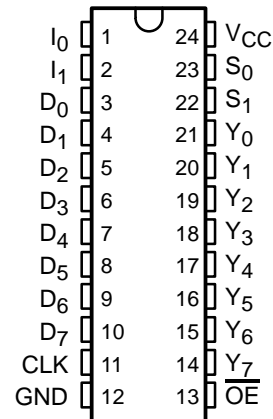

description

The CY29FCT520T is a multilevel 8-bit-wide pipeline register. The device consists of four registers, A1, A2, B1, and B2, which are configured by the instruction inputs I_0 , I_1 as a single four-level pipeline or as two two-level pipelines. The contents of any register can be read at the multiplexed output at any time by using the multiplex-selection controls (S_0 and S_1).

The pipeline registers are positive-edge triggered, and data is shifted by the rising edge of the clock input. Instruction $I = 0$ selects the four-level pipeline mode. Instruction $I = 1$ selects the two-level B pipeline, while $I = 2$ selects the two-level A pipeline. $I = 3$ is the hold instruction; no shifting is performed by the clock in this mode.

In the two-level operation mode, data is shifted from level 1 to level 2 and new data is loaded into level 1.

This device is fully specified for partial-power-down applications using I_{off} . The I_{off} circuitry disables the outputs, preventing damaging current backflow through the device when it is powered down.



Please be aware that an important notice concerning availability, standard warranty, and use in critical applications of Texas Instruments semiconductor products and disclaimers thereto appears at the end of this data sheet.

PRODUCTION DATA information is current as of publication date. Products conform to specifications per the terms of Texas Instruments standard warranty. Production processing does not necessarily include testing of all parameters.

**TEXAS
INSTRUMENTS**

POST OFFICE BOX 655303 • DALLAS, TEXAS 75265

Copyright © 2001, Texas Instruments Incorporated
On products compliant to MIL-PRF-38535, all parameters are tested unless otherwise noted. On all other products, production processing does not necessarily include testing of all parameters.

CY29FCT520T MULTILEVEL PIPELINE REGISTER WITH 3-STATE OUTPUTS

SCCS011C – MAY 1994 – REVISED NOVEMBER 2001

PIPELINE INSTRUCTION TABLE

I = 0		I = 1		I = 2		I = 3	
I ₁ = 0	I ₀ = 0	I ₁ = 0	I ₀ = 1	I ₁ = 1	I ₀ = 0	I ₁ = 1	I ₀ = 1
Single four-level		Dual two-level				Hold	

ORDERING INFORMATION

T _A	PACKAGE†		SPEED (ns)	ORDERABLE PART NUMBER	TOP-SIDE MARKING
-40°C to 85°C	SOIC – SO	Tube	6.0	CY29FCT520CTSOC	29FCT520C
		Tape and reel	6.0	CY29FCT520CTSOCT	
	SOIC – SO	Tube	7.5	CY29FCT520BTSOC	29FCT520B
		Tape and reel	7.5	CY29FCT520BTSOCT	
	DIP – P	Tube	14.0	CY29FCT520ATPC	CY29FCT520ATPC
	SOIC – SO	Tube	14.0	CY29FCT520ATSOC	29FCT520A
Tape and reel		14.0	CY29FCT520ATSOCT		
-55°C to 125°C	CDIP – D	Tube	8.0	5962-9220504MLA (CY29FCT520BTDMB)	
		Tube	16.0	5962-9220502MLA (CY29FCT520ATDMB)	

† Package drawings, standard packing quantities, thermal data, symbolization, and PCB design guidelines are available at www.ti.com/sc/package.

FUNCTION TABLE

INPUTS		OUTPUT
S ₁	S ₀	
1	1	A1
1	0	A2
0	1	B1
0	0	B2

logic diagram

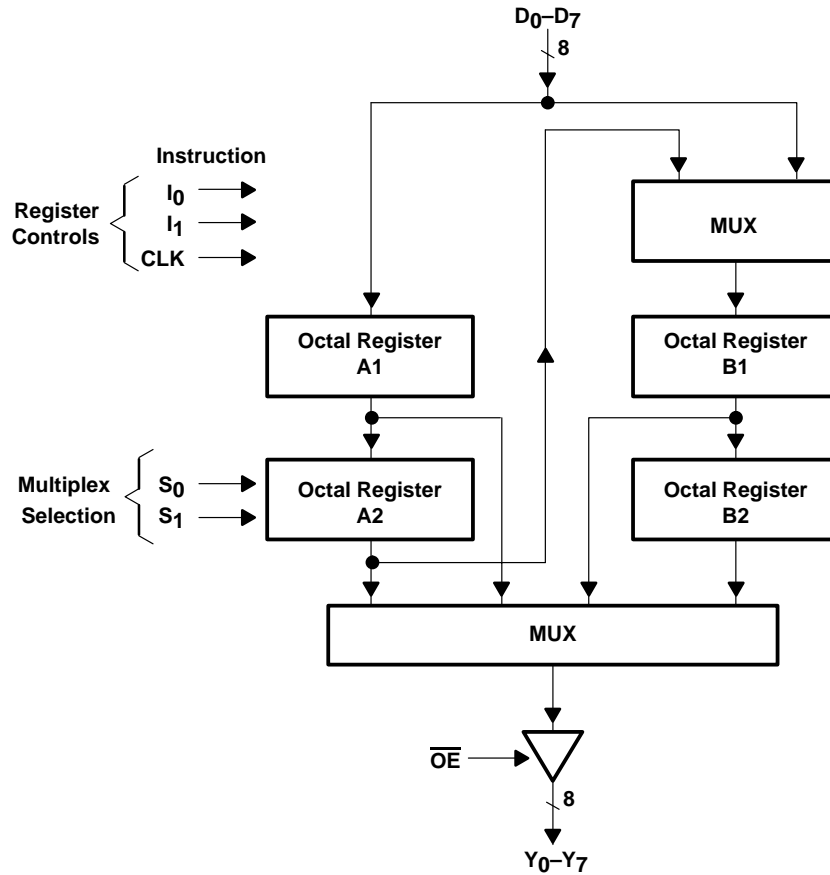

absolute maximum ratings over operating free-air temperature range (unless otherwise noted)†

Supply voltage range to ground potential	-0.5 V to 7 V
DC input voltage range	-0.5 V to 7 V
DC output voltage range	-0.5 V to 7 V
DC output current (maximum sink current/pin)	120 mA
Package thermal impedance, θ_{JA} (see Note 1): P package	67°C/W
(see Note 2): SO package	46°C/W
Ambient temperature range with power applied, T_A	-65°C to 135°C
Storage temperature range, T_{stg}	-65°C to 150°C

† Stresses beyond those listed under “absolute maximum ratings” may cause permanent damage to the device. These are stress ratings only, and functional operation of the device at these or any other conditions beyond those indicated under “recommended operating conditions” is not implied. Exposure to absolute-maximum-rated conditions for extended periods may affect device reliability.

- NOTES: 1. The package thermal impedance is calculated in accordance with JESD 51-3.
 2. The package thermal impedance is calculated in accordance with JESD 51-7.

CY29FCT520T

MULTILEVEL PIPELINE REGISTER

WITH 3-STATE OUTPUTS

SCCS011C – MAY 1994 – REVISED NOVEMBER 2001

recommended operating conditions (see Note 3)

		CY29FCT520ATDMB CY29FCT520BTDMB			CY29FCT520T			UNIT
		MIN	NOM	MAX	MIN	NOM	MAX	
V _{CC}	Supply voltage	4.5	5	5.5	4.75	5	5.25	V
V _{IH}	High-level input voltage	2			2			V
V _{IL}	Low-level input voltage			0.8			0.8	V
I _{OH}	High-level output current			-12			-32	mA
I _{OL}	Low-level output current			32			64	mA
T _A	Operating free-air temperature	-55		125	-40		85	°C

NOTE 3: All unused inputs of the device must be held at V_{CC} or GND to ensure proper device operation.

electrical characteristics over recommended operating free-air temperature range (unless otherwise noted)

PARAMETER	TEST CONDITIONS		CY29FCT520ATDMB CY29FCT520BTDMB			CY29FCT520T			UNIT
			MIN	TYP†	MAX	MIN	TYP†	MAX	
V _{IK}	V _{CC} = 4.5 V, I _{IN} = -18 mA			-0.7	-1.2				V
	V _{CC} = 4.75 V, I _{IN} = -18 mA					-0.7	-1.2		
V _{OH}	V _{CC} = 4.5 V, I _{OH} = -12 mA		2.4	3.3					V
	V _{CC} = 4.75 V	I _{OH} = -15 mA			2.4	3.3			
		I _{OH} = -32 mA			2				
V _{OL}	V _{CC} = 4.5 V, I _{OL} = 32 mA			0.3	0.55				V
	V _{CC} = 4.75 V, I _{OL} = 64 mA					0.3	0.55		
V _{hys}	All inputs			0.2		0.2		V	
I _I	V _{CC} = 5.5 V, V _{IN} = V _{CC}				5				μA
	V _{CC} = 5.25 V, V _{IN} = V _{CC}						5		
I _{IH}	V _{CC} = 5.5 V, V _{IN} = 2.7 V				±1				μA
	V _{CC} = 5.25 V, V _{IN} = 2.7 V						±1		
I _{IL}	V _{CC} = 5.5 V, V _{IN} = 0.5 V				±1				μA
	V _{CC} = 5.25 V, V _{IN} = 0.5 V						±1		
I _{off}	V _{CC} = 0 V, V _{OUT} = 4.5 V				±1		±1	μA	
I _{OS} ‡	V _{CC} = 5.5 V, V _{OUT} = 0 V		-60	-120	-225				mA
	V _{CC} = 5.25 V, V _{OUT} = 0 V					-60	-120	-225	
I _{OZH}	V _{CC} = 5.5 V, V _{IN} = 2.7 V				10				μA
	V _{CC} = 5.25 V, V _{IN} = 2.7 V						10		
I _{OZL}	V _{CC} = 5.5 V, V _{IN} = 0.5 V				-10				μA
	V _{CC} = 5.25 V, V _{IN} = 0.5 V						-10		
I _{CC}	V _{CC} = 5.5 V, V _{IN} ≤ 0.2 V, V _{IN} ≥ V _{CC} - 0.2 V			0.1	0.2				mA
	V _{CC} = 5.25 V, V _{IN} ≤ 0.2 V, V _{IN} ≥ V _{CC} - 0.2 V					0.1	0.2		
ΔI _{CC}	V _{CC} = 5.5 V, V _{IN} = 3.4 V§, f ₁ = 0, Outputs open			0.5	2				mA
	V _{CC} = 5.25 V, V _{IN} = 3.4 V§, f ₁ = 0, Outputs open					0.5	2		

† Typical values are at V_{CC} = 5 V, T_A = 25°C.

‡ Not more than one output should be shorted at a time. Duration of short should not exceed one second. The use of high-speed test apparatus and/or sample-and-hold techniques are preferable to minimize internal chip heating and more accurately reflect operational values. Otherwise, prolonged shorting of a high output can raise the chip temperature well above normal and cause invalid readings in other parametric tests. In any sequence of parameter tests, I_{OS} tests should be performed last.

§ Per TTL-driven input (V_{IN} = 3.4 V); all other inputs at V_{CC} or GND



CY29FCT520T
MULTILEVEL PIPELINE REGISTER
WITH 3-STATE OUTPUTS

SCCS011C – MAY 1994 – REVISED NOVEMBER 2001

electrical characteristics over recommended operating free-air temperature range (unless otherwise noted) (continued)

PARAMETER	TEST CONDITIONS		CY29FCT520ATDMB CY29FCT520BTDMB			CY29FCT520T			UNIT
			MIN	TYP†	MAX	MIN	TYP†	MAX	
I_{CCD}^{\ddagger}	V _{CC} = 5.5 V, Outputs open, One bit switching at 50% duty cycle, $\overline{OE} = GND$, V _{IN} ≤ 0.2 V or V _{IN} ≥ V _{CC} – 0.2 V			0.06	0.12				mA/ MHz
	V _{CC} = 5.25 V, Outputs open, One bit switching at 50% duty cycle, $\overline{OE} = GND$, V _{IN} ≤ 0.2 V or V _{IN} ≥ V _{CC} – 0.2 V					0.06	0.12		
$I_C^{\#}$	V _{CC} = 5.5 V, Outputs open, f ₀ = 10 MHz, $\overline{OE} = GND$	One bit switching at f ₁ = 5 MHz at 50% duty cycle	V _{IN} ≤ 0.2 V or V _{IN} ≥ V _{CC} – 0.2 V	0.7	1.4			mA	
			V _{IN} = 3.4 V or GND	1.2	3.4				
		Eight bits switching at f ₁ = 5 MHz at 50% duty cycle	V _{IN} ≤ 0.2 V or V _{IN} ≥ V _{CC} – 0.2 V	2.8	5.6				
			V _{IN} = 3.4 V or GND	5.1	14.3				
	V _{CC} = 5.25 V, Outputs open, f ₀ = 10 MHz, $\overline{OE} = GND$	One bit switching at f ₁ = 5 MHz at 50% duty cycle	V _{IN} ≤ 0.2 V or V _{IN} ≥ V _{CC} – 0.2 V			0.7	1.4		
			V _{IN} = 3.4 V or GND			1.2	3.4		
		Eight bits switching at f ₁ = 5 MHz at 50% duty cycle	V _{IN} ≤ 0.2 V or V _{IN} ≥ V _{CC} – 0.2 V			2.8	5.6		
			V _{IN} = 3.4 V or GND			5.1	14.3		
C _i			5	10	5	10	pF		
C _o			9	12	9	12	pF		

† Typical values are at V_{CC} = 5 V, T_A = 25°C.

‡ This parameter is derived for use in total power-supply calculations.

$I_C = I_{CC} + \Delta I_{CC} \times D_H \times N_T + I_{CCD} (f_0/2 + f_1 \times N_1)$

Where:

I_C = Total supply current

I_{CC} = Power-supply current with CMOS input levels

ΔI_{CC} = Power-supply current for a TTL high input (V_{IN} = 3.4 V)

D_H = Duty cycle for TTL inputs high

N_T = Number of TTL inputs at D_H

I_{CCD} = Dynamic current caused by an input transition pair (HLH or LHL)

f₀ = Clock frequency for registered devices, otherwise zero

f₁ = Input signal frequency

N₁ = Number of inputs changing at f₁

All currents are in milliamperes and all frequencies are in megahertz.

|| Values for these conditions are examples of the I_{CC} formula.



CY29FCT520T MULTILEVEL PIPELINE REGISTER WITH 3-STATE OUTPUTS

SCCS011C – MAY 1994 – REVISED NOVEMBER 2001

timing requirements over recommended operating free-air temperature range (unless otherwise noted) (see Figure 1)

		CY29FCT520ATDMB		CY29FCT520BTDMB		UNIT
		MIN	MAX	MIN	MAX	
t_w	Pulse duration, CLK high or low	8		6		ns
t_{su}	Setup time, before CLK \uparrow	Data	6	2.8		ns
		I	6	4.5		
t_h	Hold time, after CLK \uparrow	Data	2	2		ns
		I	2	2		

timing requirements over recommended operating free-air temperature range (unless otherwise noted) (see Figure 1)

		CY29FCT520AT		CY29FCT520BT		CY29FCT520CT		UNIT
		MIN	MAX	MIN	MAX	MIN	MAX	
t_w	Pulse duration, CLK high or low	7		5.5		5.5		ns
t_{su}	Setup time, before CLK \uparrow	Data	5	2.5		2.5		ns
		I	5	4		4		
t_h	Hold time, after CLK \uparrow	Data	2	2		2		ns
		I	2	2		2		

switching characteristics over operating free-air temperature range (see Figure 1)

PARAMETER	FROM (INPUT)	TO (OUTPUT)	CY29FCT520ATDMB		CY29FCT520BTDMB		UNIT
			MIN	MAX	MIN	MAX	
t_{PLH}	CLK	Y	2	16	2	8	ns
t_{PHL}			2	16	2	8	
t_{PLH}	S_0 or S_1	Y	2	15	2	8	ns
t_{PHL}			2	15	2	8	
t_{PHZ}	\overline{OE}	Y	1.5	13	1.5	7.5	ns
t_{PLZ}			1.5	13	1.5	7.5	
t_{PZH}	\overline{OE}	Y	1.5	16	1.5	8	ns
t_{PZL}			1.5	16	1.5	8	

switching characteristics over operating free-air temperature range (see Figure 1)

PARAMETER	FROM (INPUT)	TO (OUTPUT)	CY29FCT520AT		CY29FCT520BT		CY29FCT520CT		UNIT
			MIN	MAX	MIN	MAX	MIN	MAX	
t_{PLH}	CLK	Y	2	14	2	7.5	2	6	ns
t_{PHL}			2	14	2	7.5	2	6	
t_{PLH}	S_0 or S_1	Y	2	13	2	7.5	2	6	ns
t_{PHL}			2	13	2	7.5	2	6	
t_{PHZ}	\overline{OE}	Y	1.5	12	1.5	7	1.5	6	ns
t_{PLZ}			1.5	12	1.5	7	1.5	6	
t_{PZH}	\overline{OE}	Y	1.5	15	1.5	7.5	1.5	6	ns
t_{PZL}			1.5	15	1.5	7.5	1.5	6	



PARAMETER MEASUREMENT INFORMATION

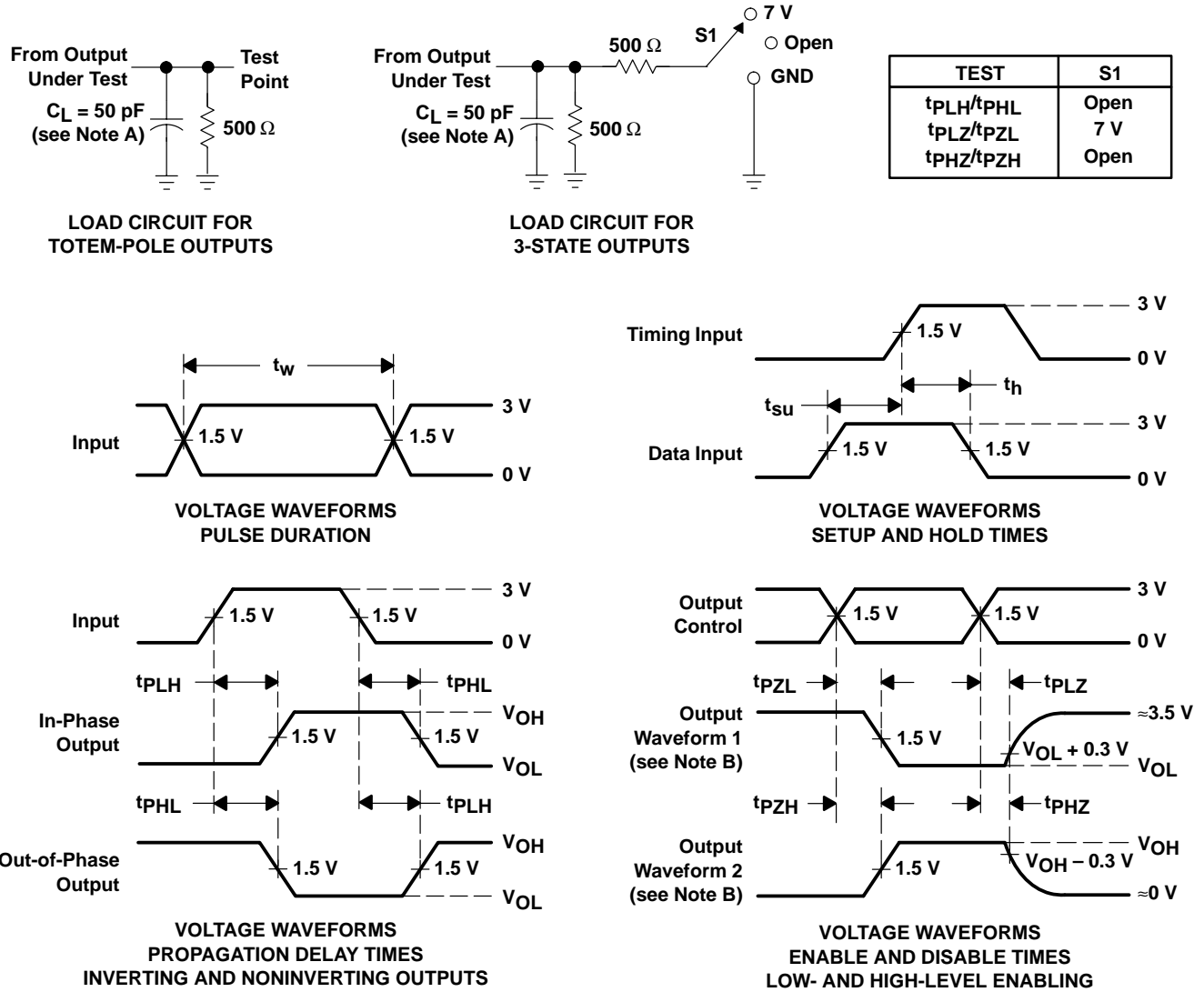

- NOTES: A. C_L includes probe and jig capacitance.
 B. Waveform 1 is for an output with internal conditions such that the output is low except when disabled by the output control. Waveform 2 is for an output with internal conditions such that the output is high except when disabled by the output control.
 C. The outputs are measured one at a time with one input transition per measurement.

Figure 1. Load Circuit and Voltage Waveforms

PACKAGING INFORMATION

Orderable Device	Status (1)	Package Type	Package Drawing	Pins	Package Qty	Eco Plan (2)	Lead/Ball Finish (6)	MSL Peak Temp (3)	Op Temp (°C)	Device Marking (4/5)	Samples
5962-9220502MLA	ACTIVE	CDIP	JT	24	1	TBD	A42	N / A for Pkg Type	-55 to 125	5962-9220502ML A	Samples
5962-9220504MLA	ACTIVE	CDIP	JT	24	1	TBD	A42	N / A for Pkg Type	-55 to 125	5962-9220504ML A	Samples
CY29FCT520ATSOC	ACTIVE	SOIC	DW	24	25	Green (RoHS & no Sb/Br)	CU NIPDAU	Level-1-260C-UNLIM	-40 to 85	29FCT520A	Samples
CY29FCT520BTSOC	ACTIVE	SOIC	DW	24	25	Green (RoHS & no Sb/Br)	CU NIPDAU	Level-1-260C-UNLIM	-40 to 85	29FCT520B	Samples

(1) The marketing status values are defined as follows:

ACTIVE: Product device recommended for new designs.

LIFEBUY: TI has announced that the device will be discontinued, and a lifetime-buy period is in effect.

NRND: Not recommended for new designs. Device is in production to support existing customers, but TI does not recommend using this part in a new design.

PREVIEW: Device has been announced but is not in production. Samples may or may not be available.

OBSELETE: TI has discontinued the production of the device.

(2) Eco Plan - The planned eco-friendly classification: Pb-Free (RoHS), Pb-Free (RoHS Exempt), or Green (RoHS & no Sb/Br) - please check <http://www.ti.com/productcontent> for the latest availability information and additional product content details.

TBD: The Pb-Free/Green conversion plan has not been defined.

Pb-Free (RoHS): TI's terms "Lead-Free" or "Pb-Free" mean semiconductor products that are compatible with the current RoHS requirements for all 6 substances, including the requirement that lead not exceed 0.1% by weight in homogeneous materials. Where designed to be soldered at high temperatures, TI Pb-Free products are suitable for use in specified lead-free processes.

Pb-Free (RoHS Exempt): This component has a RoHS exemption for either 1) lead-based flip-chip solder bumps used between the die and package, or 2) lead-based die adhesive used between the die and leadframe. The component is otherwise considered Pb-Free (RoHS compatible) as defined above.

Green (RoHS & no Sb/Br): TI defines "Green" to mean Pb-Free (RoHS compatible), and free of Bromine (Br) and Antimony (Sb) based flame retardants (Br or Sb do not exceed 0.1% by weight in homogeneous material)

(3) MSL, Peak Temp. - The Moisture Sensitivity Level rating according to the JEDEC industry standard classifications, and peak solder temperature.

(4) There may be additional marking, which relates to the logo, the lot trace code information, or the environmental category on the device.

(5) Multiple Device Markings will be inside parentheses. Only one Device Marking contained in parentheses and separated by a "~" will appear on a device. If a line is indented then it is a continuation of the previous line and the two combined represent the entire Device Marking for that device.

(6) Lead/Ball Finish - Orderable Devices may have multiple material finish options. Finish options are separated by a vertical ruled line. Lead/Ball Finish values may wrap to two lines if the finish value exceeds the maximum column width.

Important Information and Disclaimer: The information provided on this page represents TI's knowledge and belief as of the date that it is provided. TI bases its knowledge and belief on information provided by third parties, and makes no representation or warranty as to the accuracy of such information. Efforts are underway to better integrate information from third parties. TI has taken and continues to take reasonable steps to provide representative and accurate information but may not have conducted destructive testing or chemical analysis on incoming materials and chemicals. TI and TI suppliers consider certain information to be proprietary, and thus CAS numbers and other limited information may not be available for release.

In no event shall TI's liability arising out of such information exceed the total purchase price of the TI part(s) at issue in this document sold by TI to Customer on an annual basis.

JT (R-GDIP-T**)

CERAMIC DUAL-IN-LINE

24 LEADS SHOWN

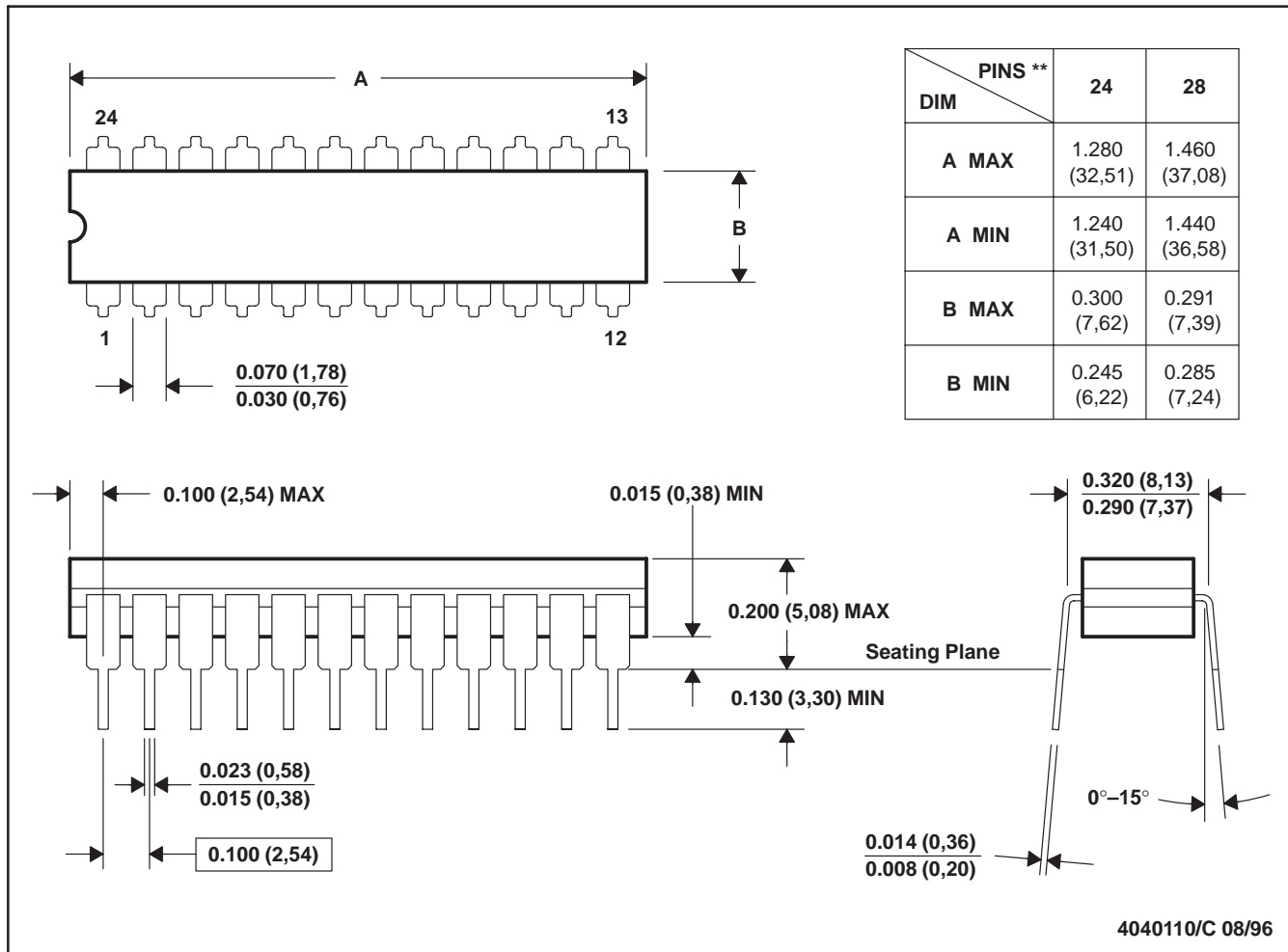

- NOTES: A. All linear dimensions are in inches (millimeters).
 B. This drawing is subject to change without notice.
 C. This package can be hermetically sealed with a ceramic lid using glass frit.
 D. Index point is provided on cap for terminal identification.
 E. Falls within MIL STD 1835 GDIP3-T24, GDIP4-T28, and JEDEC MO-058 AA, MO-058 AB

DW (R-PDSO-G24)

PLASTIC SMALL OUTLINE



- NOTES:
- A. All linear dimensions are in inches (millimeters). Dimensioning and tolerancing per ASME Y14.5M-1994.
 - B. This drawing is subject to change without notice.
 - C. Body dimensions do not include mold flash or protrusion not to exceed 0.006 (0,15).
 - D. Falls within JEDEC MS-013 variation AD.

IMPORTANT NOTICE

Texas Instruments Incorporated (TI) reserves the right to make corrections, enhancements, improvements and other changes to its semiconductor products and services per JESD46, latest issue, and to discontinue any product or service per JESD48, latest issue. Buyers should obtain the latest relevant information before placing orders and should verify that such information is current and complete.

TI's published terms of sale for semiconductor products (<http://www.ti.com/sc/docs/stdterms.htm>) apply to the sale of packaged integrated circuit products that TI has qualified and released to market. Additional terms may apply to the use or sale of other types of TI products and services.

Reproduction of significant portions of TI information in TI data sheets is permissible only if reproduction is without alteration and is accompanied by all associated warranties, conditions, limitations, and notices. TI is not responsible or liable for such reproduced documentation. Information of third parties may be subject to additional restrictions. Resale of TI products or services with statements different from or beyond the parameters stated by TI for that product or service voids all express and any implied warranties for the associated TI product or service and is an unfair and deceptive business practice. TI is not responsible or liable for any such statements.

Buyers and others who are developing systems that incorporate TI products (collectively, "Designers") understand and agree that Designers remain responsible for using their independent analysis, evaluation and judgment in designing their applications and that Designers have full and exclusive responsibility to assure the safety of Designers' applications and compliance of their applications (and of all TI products used in or for Designers' applications) with all applicable regulations, laws and other applicable requirements. Designer represents that, with respect to their applications, Designer has all the necessary expertise to create and implement safeguards that (1) anticipate dangerous consequences of failures, (2) monitor failures and their consequences, and (3) lessen the likelihood of failures that might cause harm and take appropriate actions. Designer agrees that prior to using or distributing any applications that include TI products, Designer will thoroughly test such applications and the functionality of such TI products as used in such applications.

TI's provision of technical, application or other design advice, quality characterization, reliability data or other services or information, including, but not limited to, reference designs and materials relating to evaluation modules, (collectively, "TI Resources") are intended to assist designers who are developing applications that incorporate TI products; by downloading, accessing or using TI Resources in any way, Designer (individually or, if Designer is acting on behalf of a company, Designer's company) agrees to use any particular TI Resource solely for this purpose and subject to the terms of this Notice.

TI's provision of TI Resources does not expand or otherwise alter TI's applicable published warranties or warranty disclaimers for TI products, and no additional obligations or liabilities arise from TI providing such TI Resources. TI reserves the right to make corrections, enhancements, improvements and other changes to its TI Resources. TI has not conducted any testing other than that specifically described in the published documentation for a particular TI Resource.

Designer is authorized to use, copy and modify any individual TI Resource only in connection with the development of applications that include the TI product(s) identified in such TI Resource. NO OTHER LICENSE, EXPRESS OR IMPLIED, BY ESTOPPEL OR OTHERWISE TO ANY OTHER TI INTELLECTUAL PROPERTY RIGHT, AND NO LICENSE TO ANY TECHNOLOGY OR INTELLECTUAL PROPERTY RIGHT OF TI OR ANY THIRD PARTY IS GRANTED HEREIN, including but not limited to any patent right, copyright, mask work right, or other intellectual property right relating to any combination, machine, or process in which TI products or services are used. Information regarding or referencing third-party products or services does not constitute a license to use such products or services, or a warranty or endorsement thereof. Use of TI Resources may require a license from a third party under the patents or other intellectual property of the third party, or a license from TI under the patents or other intellectual property of TI.

TI RESOURCES ARE PROVIDED "AS IS" AND WITH ALL FAULTS. TI DISCLAIMS ALL OTHER WARRANTIES OR REPRESENTATIONS, EXPRESS OR IMPLIED, REGARDING RESOURCES OR USE THEREOF, INCLUDING BUT NOT LIMITED TO ACCURACY OR COMPLETENESS, TITLE, ANY EPIDEMIC FAILURE WARRANTY AND ANY IMPLIED WARRANTIES OF MERCHANTABILITY, FITNESS FOR A PARTICULAR PURPOSE, AND NON-INFRINGEMENT OF ANY THIRD PARTY INTELLECTUAL PROPERTY RIGHTS. TI SHALL NOT BE LIABLE FOR AND SHALL NOT DEFEND OR INDEMNIFY DESIGNER AGAINST ANY CLAIM, INCLUDING BUT NOT LIMITED TO ANY INFRINGEMENT CLAIM THAT RELATES TO OR IS BASED ON ANY COMBINATION OF PRODUCTS EVEN IF DESCRIBED IN TI RESOURCES OR OTHERWISE. IN NO EVENT SHALL TI BE LIABLE FOR ANY ACTUAL, DIRECT, SPECIAL, COLLATERAL, INDIRECT, PUNITIVE, INCIDENTAL, CONSEQUENTIAL OR EXEMPLARY DAMAGES IN CONNECTION WITH OR ARISING OUT OF TI RESOURCES OR USE THEREOF, AND REGARDLESS OF WHETHER TI HAS BEEN ADVISED OF THE POSSIBILITY OF SUCH DAMAGES.

Unless TI has explicitly designated an individual product as meeting the requirements of a particular industry standard (e.g., ISO/TS 16949 and ISO 26262), TI is not responsible for any failure to meet such industry standard requirements.

Where TI specifically promotes products as facilitating functional safety or as compliant with industry functional safety standards, such products are intended to help enable customers to design and create their own applications that meet applicable functional safety standards and requirements. Using products in an application does not by itself establish any safety features in the application. Designers must ensure compliance with safety-related requirements and standards applicable to their applications. Designer may not use any TI products in life-critical medical equipment unless authorized officers of the parties have executed a special contract specifically governing such use. Life-critical medical equipment is medical equipment where failure of such equipment would cause serious bodily injury or death (e.g., life support, pacemakers, defibrillators, heart pumps, neurostimulators, and implantables). Such equipment includes, without limitation, all medical devices identified by the U.S. Food and Drug Administration as Class III devices and equivalent classifications outside the U.S.

TI may expressly designate certain products as completing a particular qualification (e.g., Q100, Military Grade, or Enhanced Product). Designers agree that it has the necessary expertise to select the product with the appropriate qualification designation for their applications and that proper product selection is at Designers' own risk. Designers are solely responsible for compliance with all legal and regulatory requirements in connection with such selection.

Designer will fully indemnify TI and its representatives against any damages, costs, losses, and/or liabilities arising out of Designer's non-compliance with the terms and provisions of this Notice.

Looking for pricing, stock, or lifecycle information?

Click below to explore more details on WIN SOURCE:

 [View CY29FCT520CTSOC on WIN SOURCE](#)

 [Texas Instruments](#) Information

Optimize Your Supply Chain with WIN SOURCE Solutions

-  Global Sourcing Solution
-  Obsolete Management
-  Cost Control Management
-  Shortage Management
-  Alternative Solution
-  Excess Inventory Management