

NEW



Compact Automotive Connectors for PCB-to-Cable Applications

CONNECTOR

MB-0175-1

MX34 Series (for Low Pin Counts)

October 2007

RoHS Compliant

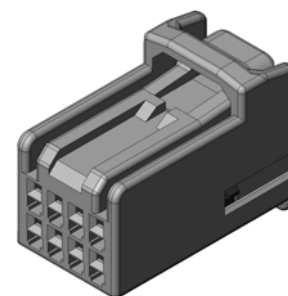
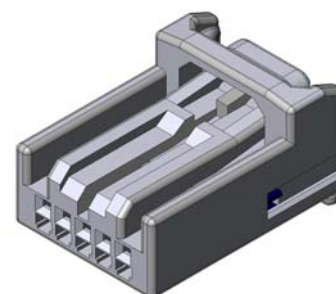
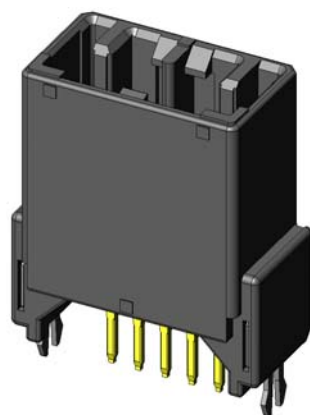
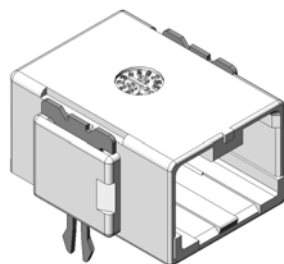
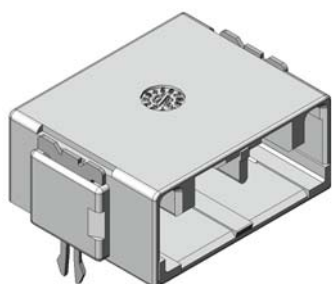

Compact, single row type connectors have been developed to add to the existing line of MX34 Series connectors for automobiles.

The available pin counts are 3, 5 and 7 positions, available in straight and angle pin header type. (Straight type is available in 5 and 7 positions)

Hook pins are placed on both sides for easier board attachment. An 8 position, double row type has also been developed.

Features

- Compact, single row PCB-to-cable connector with 2.2 mm horizontal pitch. (8 pos. is available in double row, 2.4mm pitch)
- Hook pins are placed on both sides for easier board attachment.
- Socket contact with box-type pin header is durable in external forces; contact is highly resistant to twisting and equipped with a proven double leaf spring. (In common with MX34 Series double row type)
- Adoption of a preset-type retainer facilitates easy wire harness operation. If retainer is not completely inserted in housing, the connector is not engaged, and incomplete contact insertion is detected.
- Lock spring is equipped with a bridge protecting the contacts from external load.

General Specifications

- | | |
|---|---|
| • No. of contacts: Single row 3, 5, 7 pos.
Double row 8 pos. | • Rated current: 3A |
| • Contact resistance:
5m ohm max. (initial) | • Insulation resistance: 100M ohm min |
| • Dielectric withstanding voltage:
AC 1000V (per minute) | • Durability: 50 times |
| • Operating temperature:
-40 Deg. C to +85 Deg. C | • Applicable wire:
Please refer to next page |

Materials and Finishes

•Socket Connector

Components	Materials and Finishes
Socket housing	PPE+PA66 (ALLOY)
Retainer	PPE+PA66 (ALLOY)

•Pin Connector

Components	Materials and Finishes
Pin insulator	SPS GF 30
Pin contact	Brass/Sn plating
Hook pin	Copper alloy/Sn plating

•Socket Contact

Components	Materials and Finishes
Socket contact	Highly conductive material/ Sn plating

Applicable Wire

Part Number	Applicable Wire	SJ Drawing
M34S75C4F1	AVSS0.3mm ² , CHFUS0.22mm ² ~0.35mm ²	SJ038527
M34S75C4F2	AVSS0.5mm ² , CHFUS0.5mm ² ~0.75mm ²	SJ038528
M34S75C4F3	CAN SD 0.35mm ² (note1)	SJ038747
M34S75C4F4	AVSS0.85mm ² (note1)	SJ038893

Note 1: M34S75CF3 and M34S75CF4 can only be inserted in double row cavities on both sides, two housing cavities in total.

(8 position type can be inserted in any area.)

Crimp Tool

Part Number	Hand Crimp Tool	Semi Automatic Applicator	Automatic Applicator
M34S75C4F1	CT150-2-MX34	350-MX34D-2	350-MX34D-3B
M34S75C4F2	CT150-1-MX34		
M34S75C4F3, 4	-----	350-MX34C-2	350-MX34C-3B

Withdrawal Tool

ET-MX34-1

Outside Dimension

•Socket housing

No. of	Part Number	SJ Drawing	Diameter of each area	
			A	B
3	MX34003SF1	SJ100823	4.4	10.8
5	MX34005SF1	SJ100825	8.8	15.2
7	MX34007SF1	SJ104416	13.2	19.6

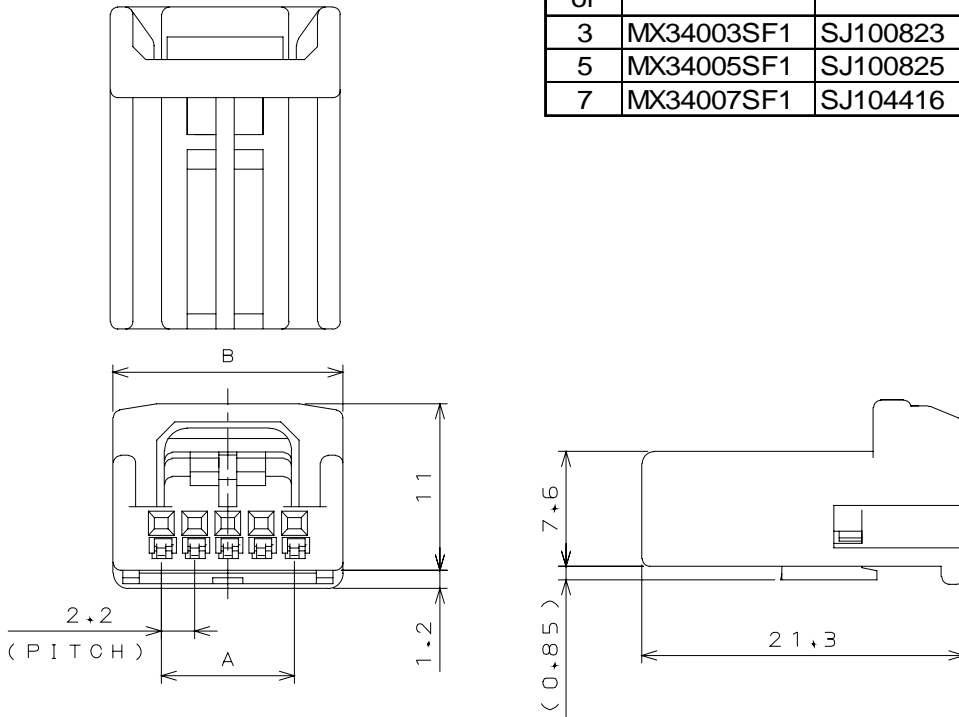

•Socket contact

1. M34S75C4F1, F2

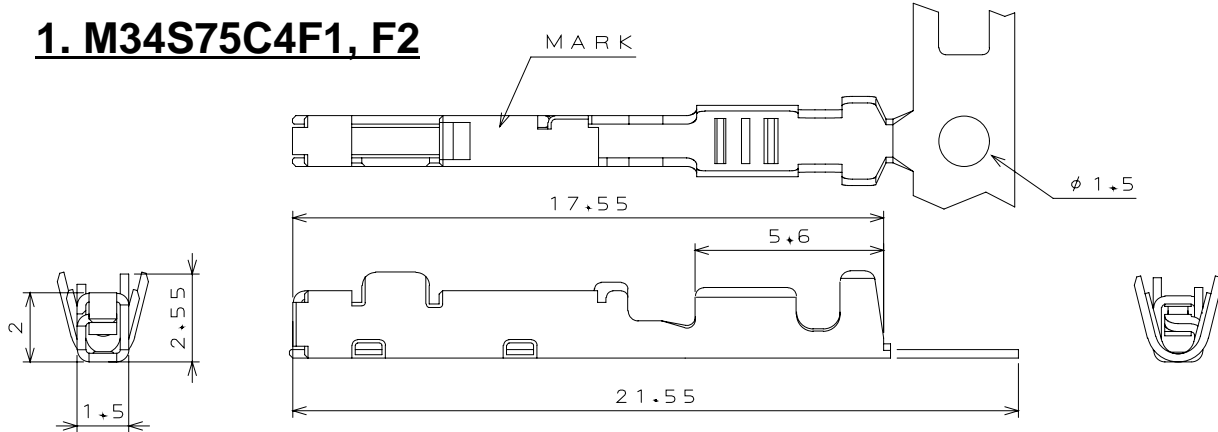

2. M34S75C4F3, F4

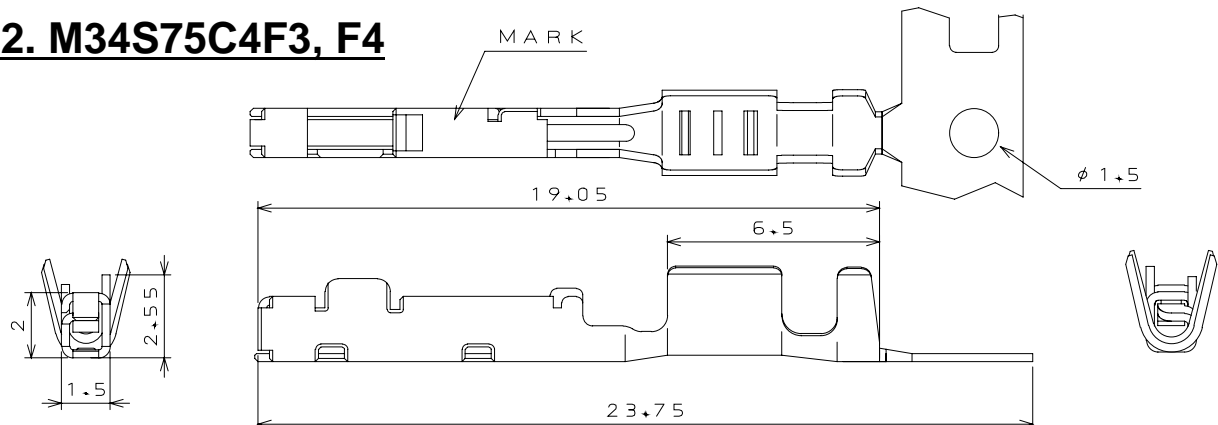

•Angle pin header

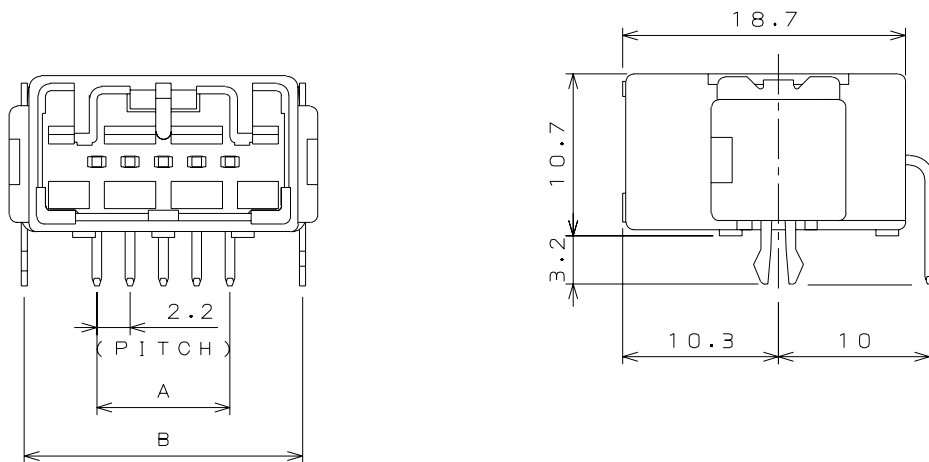
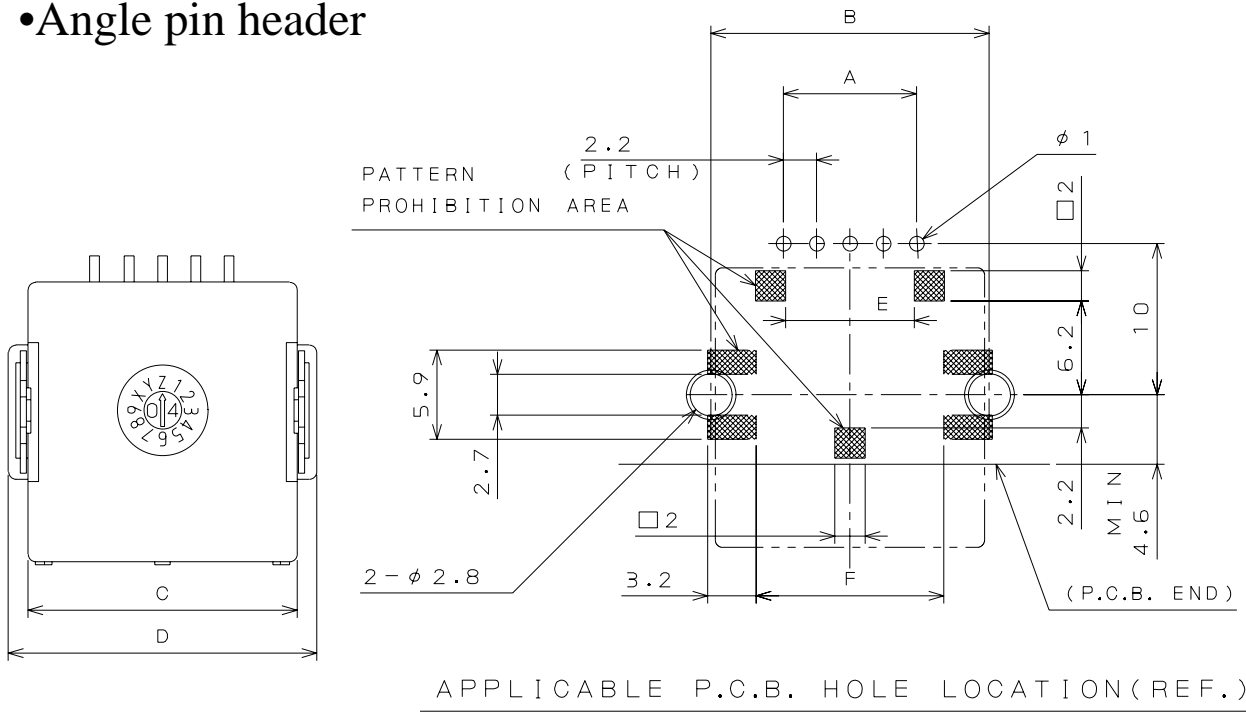

No. of pos.	Part Number	SJ Drawing	Diameter of each area					
			A	B	C	D	E	F
3	MX34003NF1	SJ100824	4.4	13.8	13.2	15.8	3.9	7.8
5	MX34005NF1	SJ100826	8.8	18.4	17.8	20.4	8.5	12.4
7	MX34007NF1	SJ104514	13.2	22.8	22.2	24.8	12.9	16.8

•Straight pin header

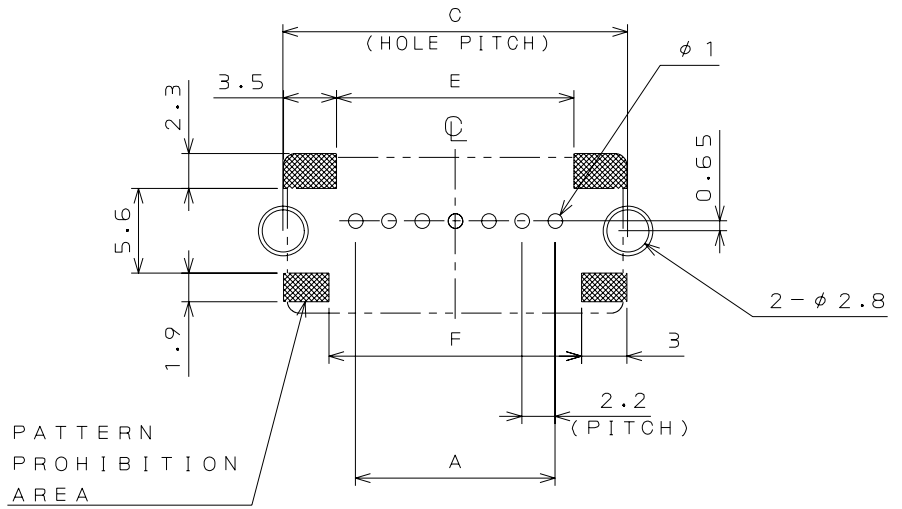
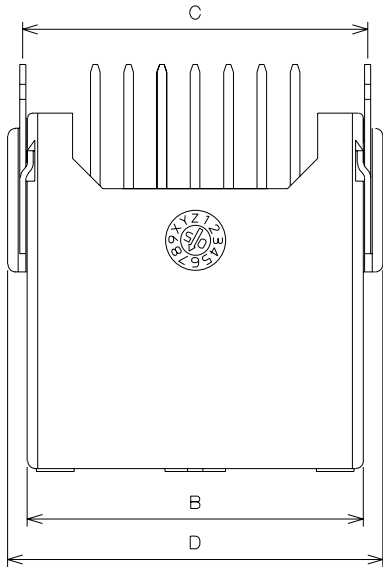

APPLICABLE P.C.B. HOLE LOCATION(REF.)

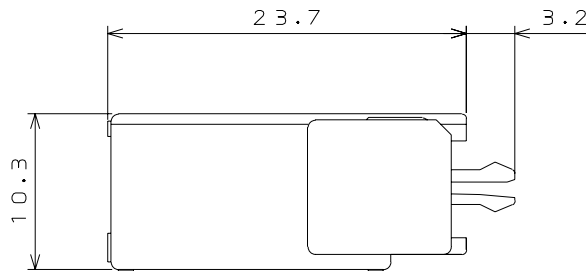
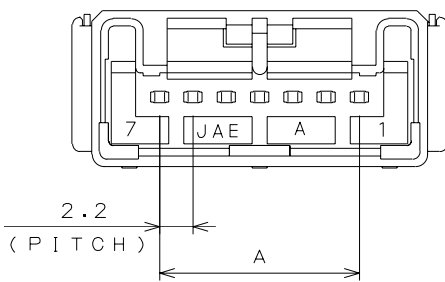

No. of pos.	Part Number	SJ Drawing	Diameter of each area					
			A	B	C	D	E	F
5	MX34005UF1	SJ104369	8.8	17.8	18.4	20.4	11.3	12.3
7	MX34007UF1	SJ104370	13.2	22.2	22.8	24.8	15.7	16.7

Note 1: 3 position not available for straight pin header

Shape of double row 8 position type

•Angle pin header (MX34E08NF1) SJ Drawing: SJ106197

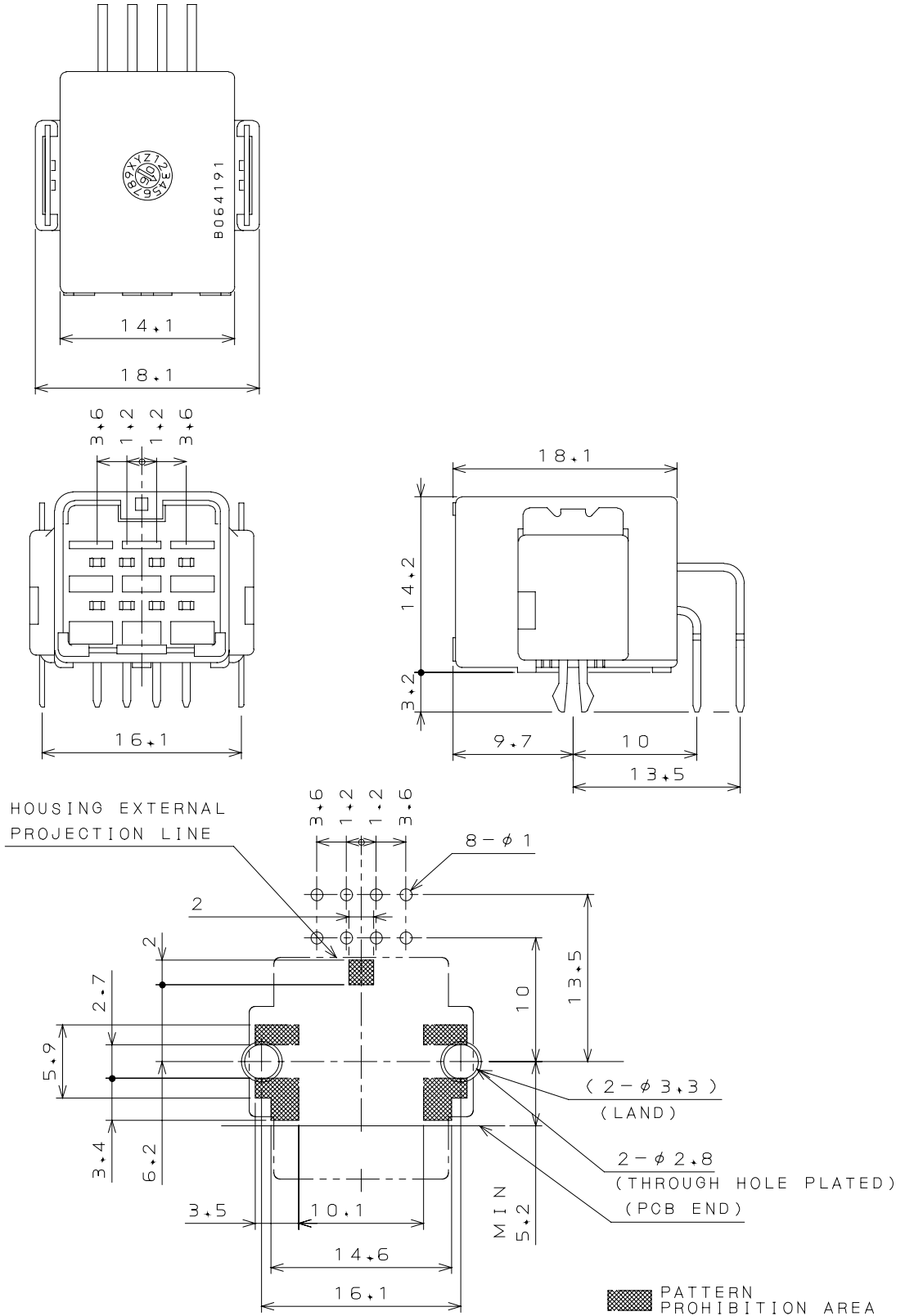

Shape of double row 8 position type

•Socket housing (MX34E08SF1) SJ Drawing: SJ106203

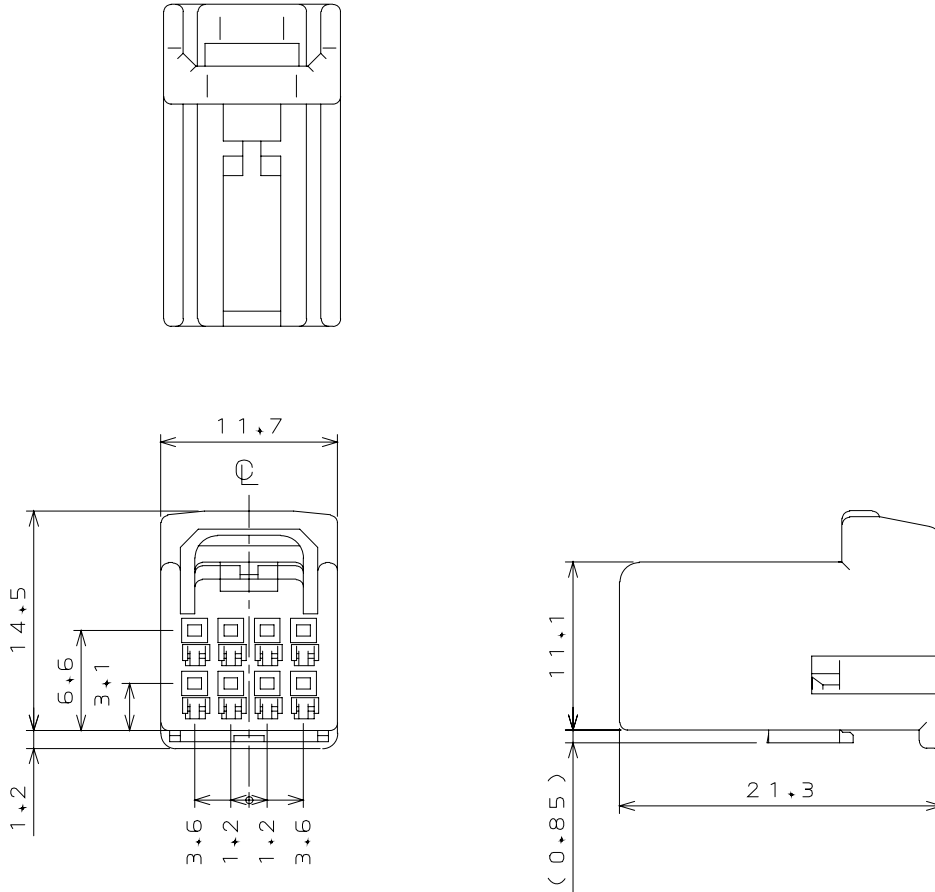

Others

Specification

JACS-1754

Handling Instructions

JACS-1754



Japan Aviation Electronics Industry, Limited

Product Marketing Division
 Aobadai Building, 3-1-19, Aobadai, Meguro-ku, Tokyo 153-8539
 Phone: +81-3-3780-2787 FAX: +81-3-3780-2946

Notice: Products shown in this leaflet are made for the applications listed below. However, if the above-mentioned products are to be used in aerospace devices, marine cable-connection devices, atomic power control systems, medical equipment for life-support systems, or any other specific application requiring extremely high reliability, please contact JAE for further information.
 Recommended applications: Computers, Office machines, Measuring devices, Telecommunication devices (Terminals, Mobile devices), AV devices, Household applications, FA devices, etc.

Looking for pricing, stock, or lifecycle information?

Click below to explore more details on WIN SOURCE:

-  [View MX34028NF2 on WIN SOURCE](#)
-  [JAE Electronics Information](#)

Optimize Your Supply Chain with WIN SOURCE Solutions

-  Global Sourcing Solution
-  Obsolete Management
-  Cost Control Management
-  Shortage Management
-  Alternative Solution
-  Excess Inventory Management