



**THE DATASHEET OF
TPD2F702YFKR**



TWO-CHANNEL EMI FILTER FOR AUDIO SPEAKER/AVIF CONNECTOR

 Check for Samples: [TPD2F702](#)

FEATURES

- Two-Channel EMI Filter for Audio Speaker or AVIF Ports
- Best in class EMI Noise Filtering for Audio Applications (-3dB Bandwidth = 1.2MHz)
- > 50 dB Crosstalk Attenuation at 100 MHz
- Integrated ESD Protection Exceeds IEC61000-4-2 (Level 4) at the Connector Ports (Level 4) on the Connector Side
 - ±15-kV Human-Body Model (HBM)
 - ±30-kV IEC 61000-4-2 Contact Discharge
 - ±30-kV IEC 61000-4-2 Air-Gap Discharge

- Pi-Style (C-R-C) Filter Configuration (C1 = 30 pF, R = 15 Ω, C2 = 5000 pF)
- Ultra Low Leakage Current (100-nA max)
- Space-Saving WCSP Package and Flow-Through Pin Mapping
- Industrial Temperature Range: –40°C to 85°C

APPLICATIONS

- Mobile Phones
- PDAs
- Headsets
- Portable Gaming

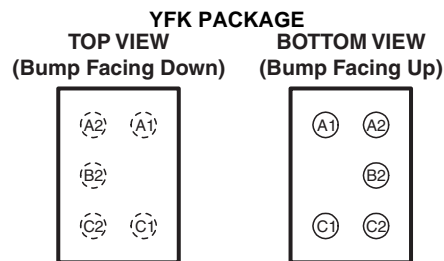

TERMINAL ASSIGNMENTS

	1	2
A	Ch 1 Input, ESD Level 1	Ch 1 Output, ESD Level 4
B	Depopulated Ball	Ground
C	Ch 2 Input, ESD Level 1	Ch 2 Output, ESD Level 4

DESCRIPTION/ORDERING INFORMATION

The TPD2F702 is a two-channel EMI filter for audio interface applications. With the integration of 5000 pF capacitor in a space saving low noise WCSP package, the TPD2F702 offers superior EMI noise suppression (2MHz to 6GHz) compared to discrete implementation. The device is optimized for AVIF connector or speaker port interfaces. This low-pass filter array also provides system level ESD protection to eliminate the need for external ESD clamps. The TPD2F702 exceeds ±30-kV ratings per IEC6100-4-2 Contact and Air-Gap specifications. It is primarily used in the mobile-phone audio headphone speaker interface, but can be used in other audio applications.

The TPD2F702 is a highly integrated device designed to suppress EMI/RFI noise in all systems subjected to electromagnetic interferences. This filter includes ESD protection circuitry which prevents damage to the application when subjected to ESD surges far exceeding IEC 61000-4-2 (Level 4).

The TPD2F702 is specified for –40°C to 85°C operation.



Please be aware that an important notice concerning availability, standard warranty, and use in critical applications of Texas Instruments semiconductor products and disclaimers thereto appears at the end of this data sheet.

ORDERING INFORMATION

T _A	PACKAGE ^{(1) (2)}	ORDERABLE PART NUMBER	TOP-SIDE MARKING
-40°C to 85°C	WCSP – YFK Tape and reel	TPD2F702YFKR	5V

- (1) Package drawings, thermal data, and symbolization are available at www.ti.com/packaging.
- (2) For the most current package and ordering information, see the Package Option Addendum at the end of this document, or see the TI Web site at www.ti.com.

**SCHEMATIC
(One of Two Channels)**

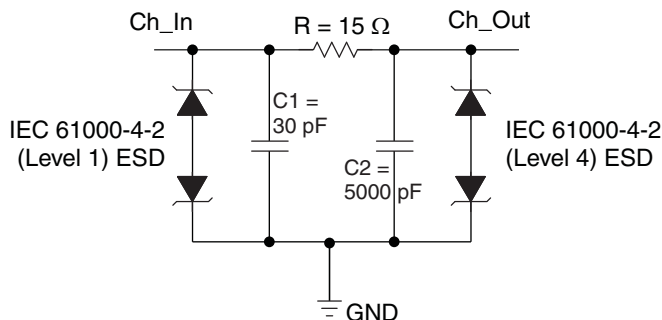

ABSOLUTE MAXIMUM RATINGS⁽¹⁾

over operating free-air temperature range (unless otherwise noted)

	MIN	MAX	UNIT
V _{IO} Continuous IO voltage	-5.5	5.5	V
Total power dissipation		200	mW
T _A Characterized free-air operating temperature range	-40	85	°C
Reflow temperature 1.6 mm (1/16 inch) from case for 10 seconds		260	°C

- (1) Stresses beyond those listed under "absolute maximum ratings" may cause permanent damage to the device. These are stress ratings only, and functional operation of the device at these or any other conditions beyond those indicated in the operational sections of the specifications is not implied. Exposure to absolute maximum rated conditions for extended periods may affect device reliability.

RECOMMENDED OPERATING CONDITIONS

	MIN	MAX	UNIT
V _{IO} Continuous IO voltage	-5	5	V

ESD RATINGS

ESD TYPE	TERMINAL	TYP	UNIT
IEC 61000-4-2 Contact Discharge	Input	±4	kV
	Output	±30	
IEC 61000-4-2 Air-Gap Discharge	Input	±4	kV
	Output	±30	
Human-Body Model	Input	±15	kV
	Output	±15	

ELECTRICAL CHARACTERISTICS

T_A = -40°C to 85°C (unless otherwise noted)

PARAMETER		TEST CONDITIONS		MIN	TYP	MAX	UNIT
V _{BR}	DC break-down voltage	I _I = 1 mA	Input pin	±14		±18.2	V
		I _O = 1 mA	Output pin	±14		±18.2	
I _{IO}	Current from input or output	V _I or V _O = 2.5 V	Input, output pins		0.01	0.1	µA
C1	Capacitance of the input terminal	V _I = 0 V, V _{OSC} = 30 mV, f = 100 kHz	Input pin		30		pF
C2	Capacitance of the output terminal	V _O = 0 V, V _{OSC} = 30 mV, f = 100 kHz	Output pin		5000		pF
R	Series resistor			12	15	18	Ω
R _{dyn}	Dynamic resistance	I _I = 1.5 A or I _O = 1.5 A	Output clamp		1		Ω
			Input clamp		3		
f _C	Cut-off frequency	Z _{SOURCE} = 50 Ω, Z _{LOAD} = 50 Ω			1.2		MHz

TYPICAL OPERATING CHARACTERISTICS

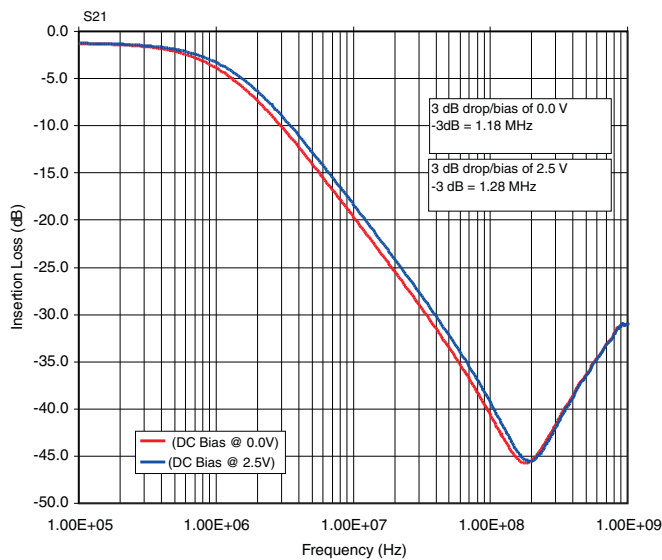

Figure 1. Insertion Loss

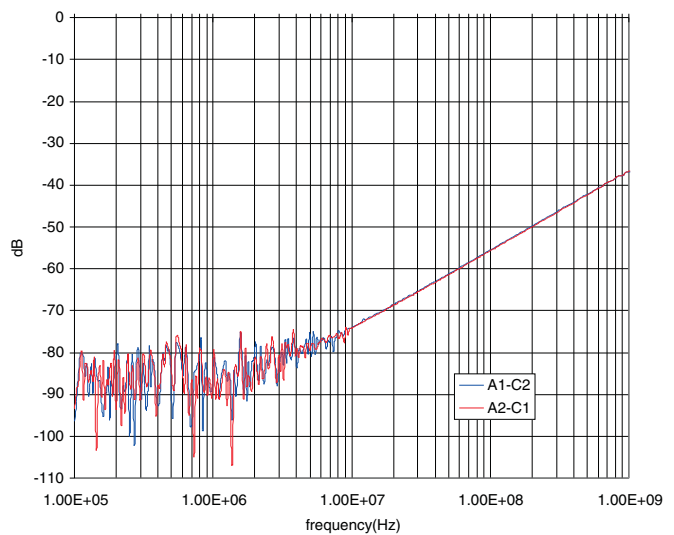

Figure 2. Channel-to-Channel Crosstalk with 50 Ω Termination for the Non-Measuring Pins

TYPICAL OPERATING CHARACTERISTICS (continued)

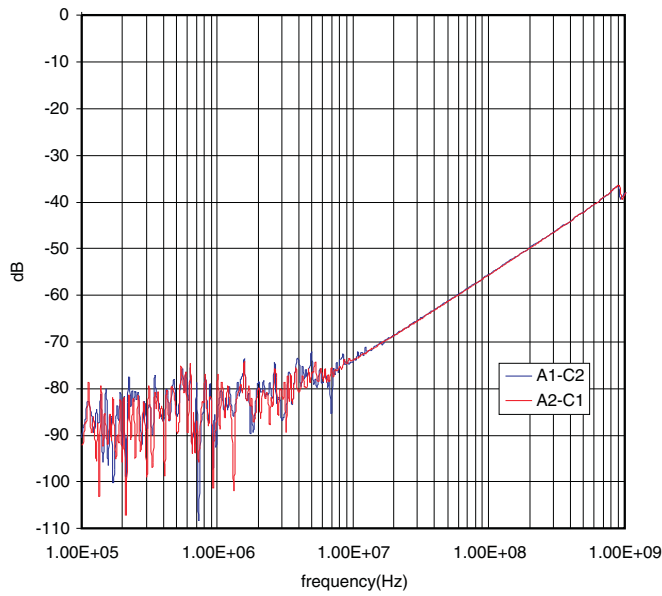

Figure 3. Channel-to-Channel Crosstalk with No Termination for the Non-Measuring Pins

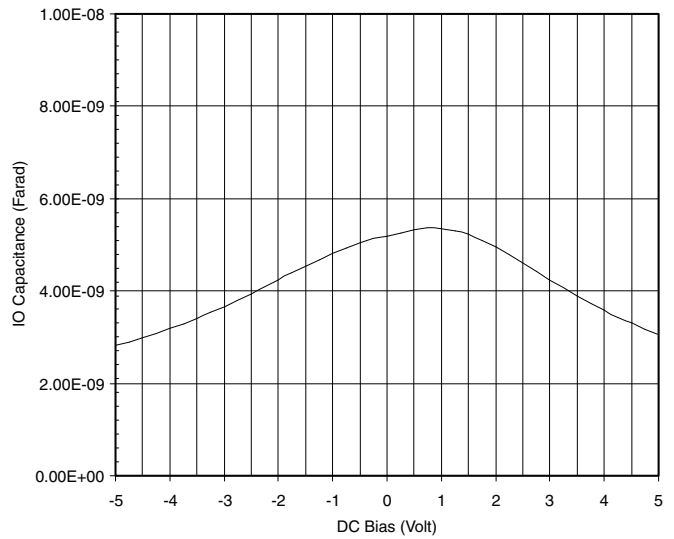

Figure 4. IO Capacitance Versus IO Voltage (Measured at f = 100 kHz)

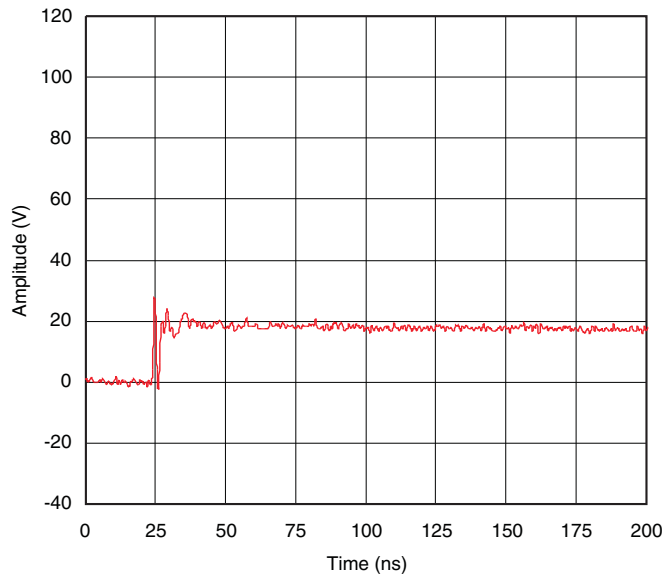

Figure 5. IEC Clamping Waveforms +8 kV Contact, Out Stressed and In Measured

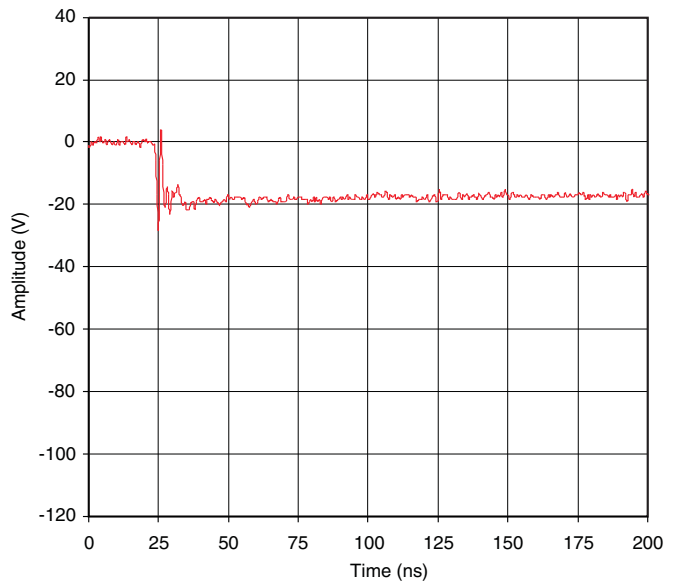

Figure 6. IEC Clamping Waveforms -8 kV Contact, Out Stressed and In Measured

TYPICAL OPERATING CHARACTERISTICS (continued)

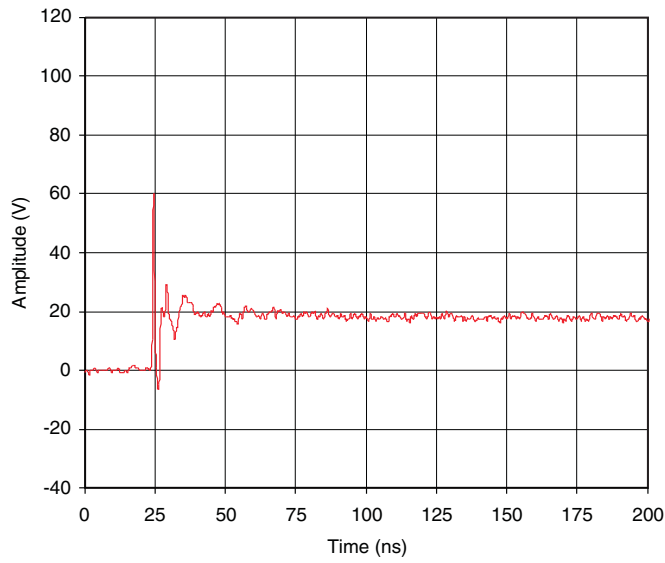

Figure 7. IEC Clamping Waveforms +15 kV Contact, Out Stressed and In Measured

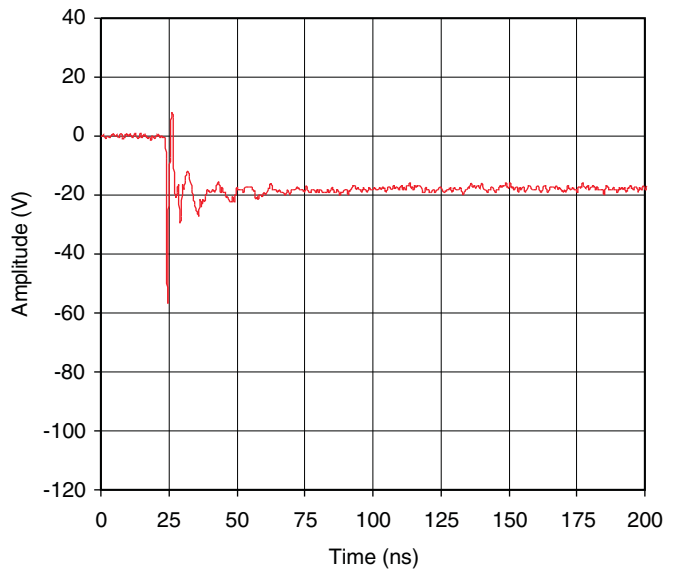

Figure 8. IEC Clamping Waveforms -15 kV Contact, Out Stressed and In Measured

TAPE AND REEL INFORMATION

QUADRANT ASSIGNMENTS FOR PIN 1 ORIENTATION IN TAPE

*All dimensions are nominal

Device	Package Type	Package Drawing	Pins	SPQ	Reel Diameter (mm)	Reel Width W1 (mm)	A0 (mm)	B0 (mm)	K0 (mm)	P1 (mm)	W (mm)	Pin1 Quadrant
TPD2F702YFKR	DSBGA	YFK	5	0	180.0	8.4	1.02	1.42	0.62	4.0	8.0	Q2

TAPE AND REEL BOX DIMENSIONS



*All dimensions are nominal

Device	Package Type	Package Drawing	Pins	SPQ	Length (mm)	Width (mm)	Height (mm)
TPD2F702YFKR	DSBGA	YFK	5	0	210.0	185.0	35.0

MECHANICAL DATA

YFK (R-XBGA-N5)

(CUSTOM) DIE-SIZE BALL GRID ARRAY

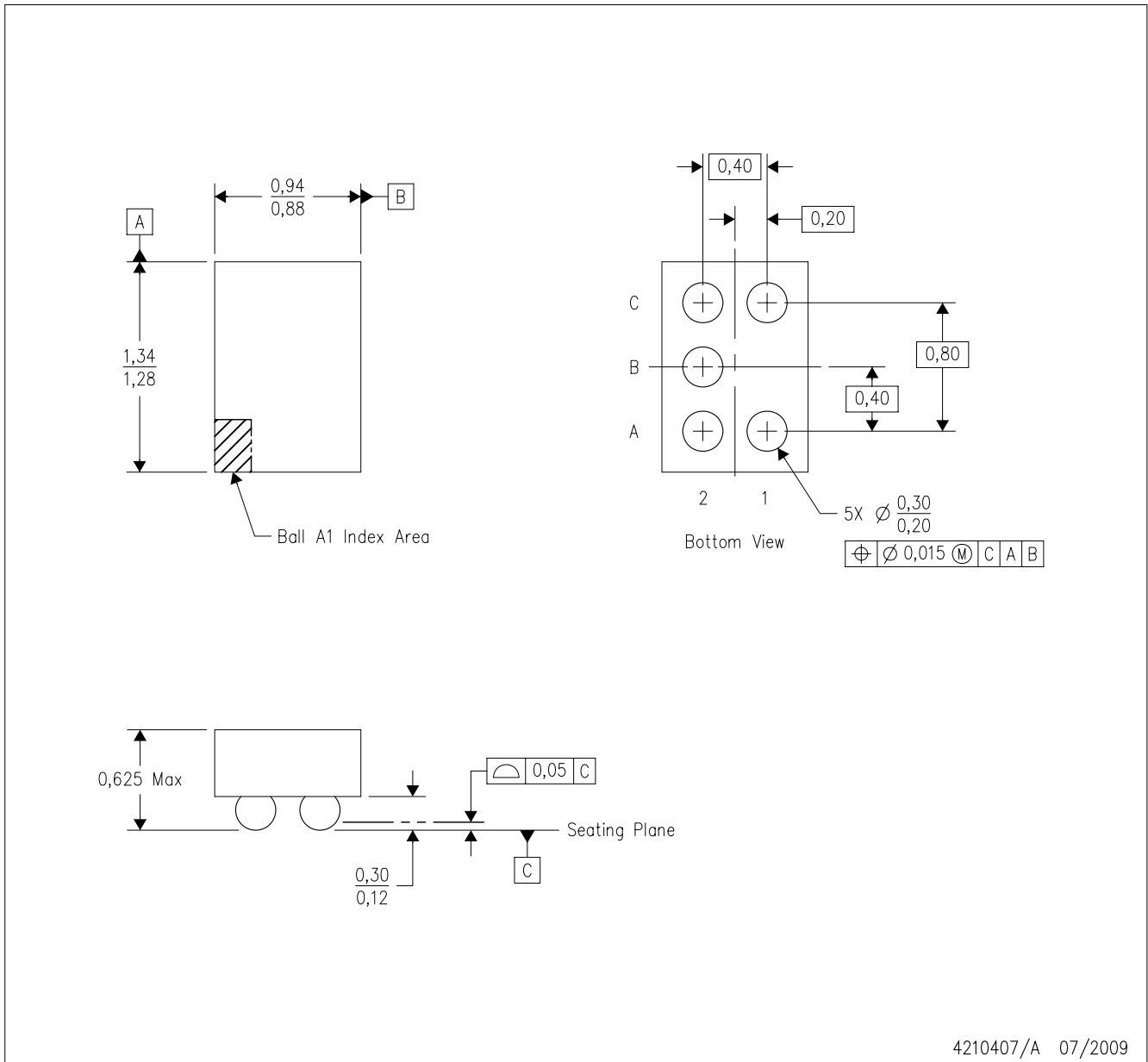

- NOTES:
- A. All linear dimensions are in millimeters. Dimensioning and tolerancing per ASME Y14.5M-1994.
 - B. This drawing is subject to change without notice.
 - C. NanoFree™ package configuration.
 - D. This is a Pb-free solder ball design.

NanoFree is a trademark of Texas Instruments.

IMPORTANT NOTICE

Texas Instruments Incorporated and its subsidiaries (TI) reserve the right to make corrections, enhancements, improvements and other changes to its semiconductor products and services per JESD46, latest issue, and to discontinue any product or service per JESD48, latest issue. Buyers should obtain the latest relevant information before placing orders and should verify that such information is current and complete. All semiconductor products (also referred to herein as "components") are sold subject to TI's terms and conditions of sale supplied at the time of order acknowledgment.

TI warrants performance of its components to the specifications applicable at the time of sale, in accordance with the warranty in TI's terms and conditions of sale of semiconductor products. Testing and other quality control techniques are used to the extent TI deems necessary to support this warranty. Except where mandated by applicable law, testing of all parameters of each component is not necessarily performed.

TI assumes no liability for applications assistance or the design of Buyers' products. Buyers are responsible for their products and applications using TI components. To minimize the risks associated with Buyers' products and applications, Buyers should provide adequate design and operating safeguards.

TI does not warrant or represent that any license, either express or implied, is granted under any patent right, copyright, mask work right, or other intellectual property right relating to any combination, machine, or process in which TI components or services are used. Information published by TI regarding third-party products or services does not constitute a license to use such products or services or a warranty or endorsement thereof. Use of such information may require a license from a third party under the patents or other intellectual property of the third party, or a license from TI under the patents or other intellectual property of TI.

Reproduction of significant portions of TI information in TI data books or data sheets is permissible only if reproduction is without alteration and is accompanied by all associated warranties, conditions, limitations, and notices. TI is not responsible or liable for such altered documentation. Information of third parties may be subject to additional restrictions.

Resale of TI components or services with statements different from or beyond the parameters stated by TI for that component or service voids all express and any implied warranties for the associated TI component or service and is an unfair and deceptive business practice. TI is not responsible or liable for any such statements.

Buyer acknowledges and agrees that it is solely responsible for compliance with all legal, regulatory and safety-related requirements concerning its products, and any use of TI components in its applications, notwithstanding any applications-related information or support that may be provided by TI. Buyer represents and agrees that it has all the necessary expertise to create and implement safeguards which anticipate dangerous consequences of failures, monitor failures and their consequences, lessen the likelihood of failures that might cause harm and take appropriate remedial actions. Buyer will fully indemnify TI and its representatives against any damages arising out of the use of any TI components in safety-critical applications.

In some cases, TI components may be promoted specifically to facilitate safety-related applications. With such components, TI's goal is to help enable customers to design and create their own end-product solutions that meet applicable functional safety standards and requirements. Nonetheless, such components are subject to these terms.

No TI components are authorized for use in FDA Class III (or similar life-critical medical equipment) unless authorized officers of the parties have executed a special agreement specifically governing such use.

Only those TI components which TI has specifically designated as military grade or "enhanced plastic" are designed and intended for use in military/aerospace applications or environments. Buyer acknowledges and agrees that any military or aerospace use of TI components which have **not** been so designated is solely at the Buyer's risk, and that Buyer is solely responsible for compliance with all legal and regulatory requirements in connection with such use.

TI has specifically designated certain components as meeting ISO/TS16949 requirements, mainly for automotive use. In any case of use of non-designated products, TI will not be responsible for any failure to meet ISO/TS16949.

Products

Audio	www.ti.com/audio
Amplifiers	amplifier.ti.com
Data Converters	dataconverter.ti.com
DLP® Products	www.dlp.com
DSP	dsp.ti.com
Clocks and Timers	www.ti.com/clocks
Interface	interface.ti.com
Logic	logic.ti.com
Power Mgmt	power.ti.com
Microcontrollers	microcontroller.ti.com
RFID	www.ti-rfid.com
OMAP Applications Processors	www.ti.com/omap
Wireless Connectivity	www.ti.com/wirelessconnectivity

Applications

Automotive and Transportation	www.ti.com/automotive
Communications and Telecom	www.ti.com/communications
Computers and Peripherals	www.ti.com/computers
Consumer Electronics	www.ti.com/consumer-apps
Energy and Lighting	www.ti.com/energy
Industrial	www.ti.com/industrial
Medical	www.ti.com/medical
Security	www.ti.com/security
Space, Avionics and Defense	www.ti.com/space-avionics-defense
Video and Imaging	www.ti.com/video

TI E2E Community

e2e.ti.com

Looking for pricing, stock, or lifecycle information?

Click below to explore more details on WIN SOURCE:

 [View TPD2F702YFKR on WIN SOURCE](#)

 [Texas Instruments](#) Information

Optimize Your Supply Chain with WIN SOURCE Solutions

-  Global Sourcing Solution
-  Obsolete Management
-  Cost Control Management
-  Shortage Management
-  Alternative Solution
-  Excess Inventory Management