



1 Overview

1.1 Features

- Delivers up to 5 A continuous 6 A peak current
- Optimized for DC motor management applications
- Operates at supply voltages up to 40 V
- Very low $R_{DS\ ON}$; typ. 200 m Ω @ 25 °C per switch
- Output full short circuit protected
- Overtemperature protection with hysteresis and diagnosis
- Short circuit and open load diagnosis with open drain error flag
- Undervoltage lockout
- CMOS/TTL compatible inputs with hysteresis
- No crossover current
- Internal freewheeling diodes
- Wide temperature range; $-40\text{ }^{\circ}\text{C} < T_j < 150\text{ }^{\circ}\text{C}$
- Green Product (RoHS compliant)
- AEC Qualified

Type	Package
TLE 5205-2	PG-TO220-7-11
TLE 5205-2GP	PG-DSO-20-37
TLE 5205-2G	PG-TO263-7-1
TLE 5205-2S	PG-TO220-7-12

Description

The TLE 5205-2 is an integrated power H-bridge with DMOS output stages for driving DC-Motors. The part is built using the Infineon multi-technology process SPT[®] which allows bipolar and CMOS control circuitry plus DMOS power devices to exist on the same monolithic structure.

Operation modes forward (cw), reverse (ccw), brake and high impedance are invoked from just two control pins with TTL/CMOS compatible levels. The combination of an extremely low $R_{DS\ ON}$ and the use of a power IC package with low thermal resistance and high thermal capacity helps to minimize system power dissipation. A blocking capacitor at the supply voltage is the only external circuitry due to the integrated freewheeling diodes.

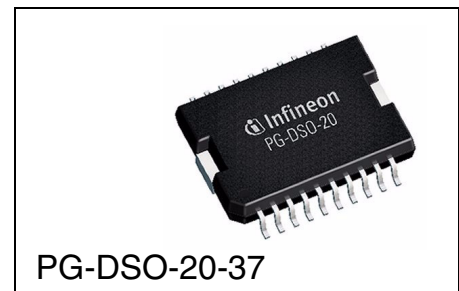

1.2 Pin Configuration (top view)

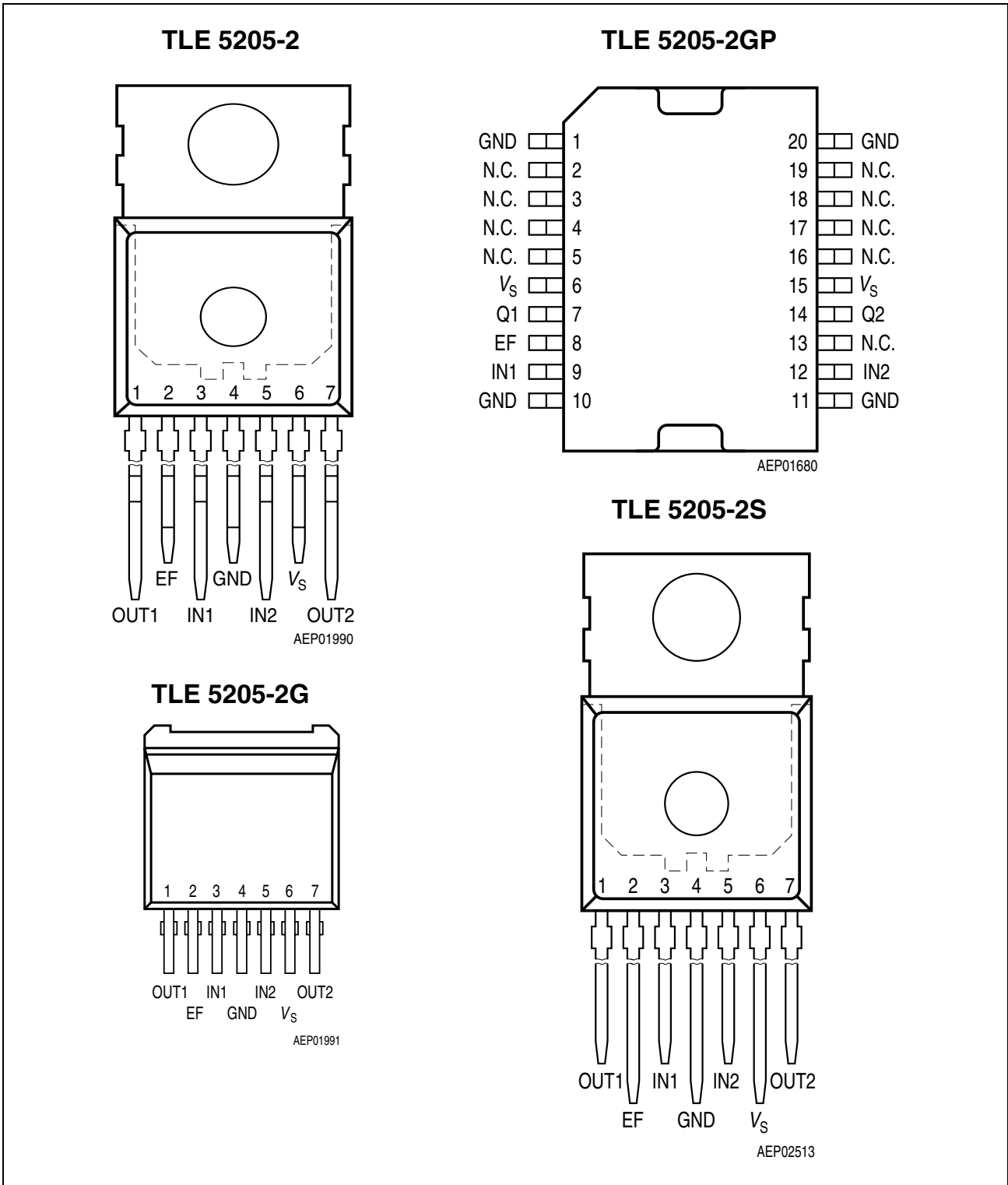

Figure 1 Pin Assignments

1.3 Pin Definitions and Functions

Pin No. P-TO220	Pin No. P-DSO	Symbol	Function
1	7	OUT1	Output of Channel 1; Short-circuit protected; integrated freewheeling diodes for inductive loads.
2	8	EF	Error Flag; TTL/CMOS compatible output for error detection; (open drain)
3	9	IN1	Control Input 1; TTL/CMOS compatible
4	1, 10, 11, 20	GND	Ground; internally connected to tab
5	12	IN2	Control Input 2; TTL/CMOS compatible
6	6, 15	V_S	Supply Voltage; block to GND
7	14	OUT2	Output of Channel 2; Short-circuit protected; integrated freewheeling diodes for inductive loads.
–	2, 3, 4, 5, 16, 17, 18, 19	N.C.	Not Connected

1.4 Functional Block Diagram

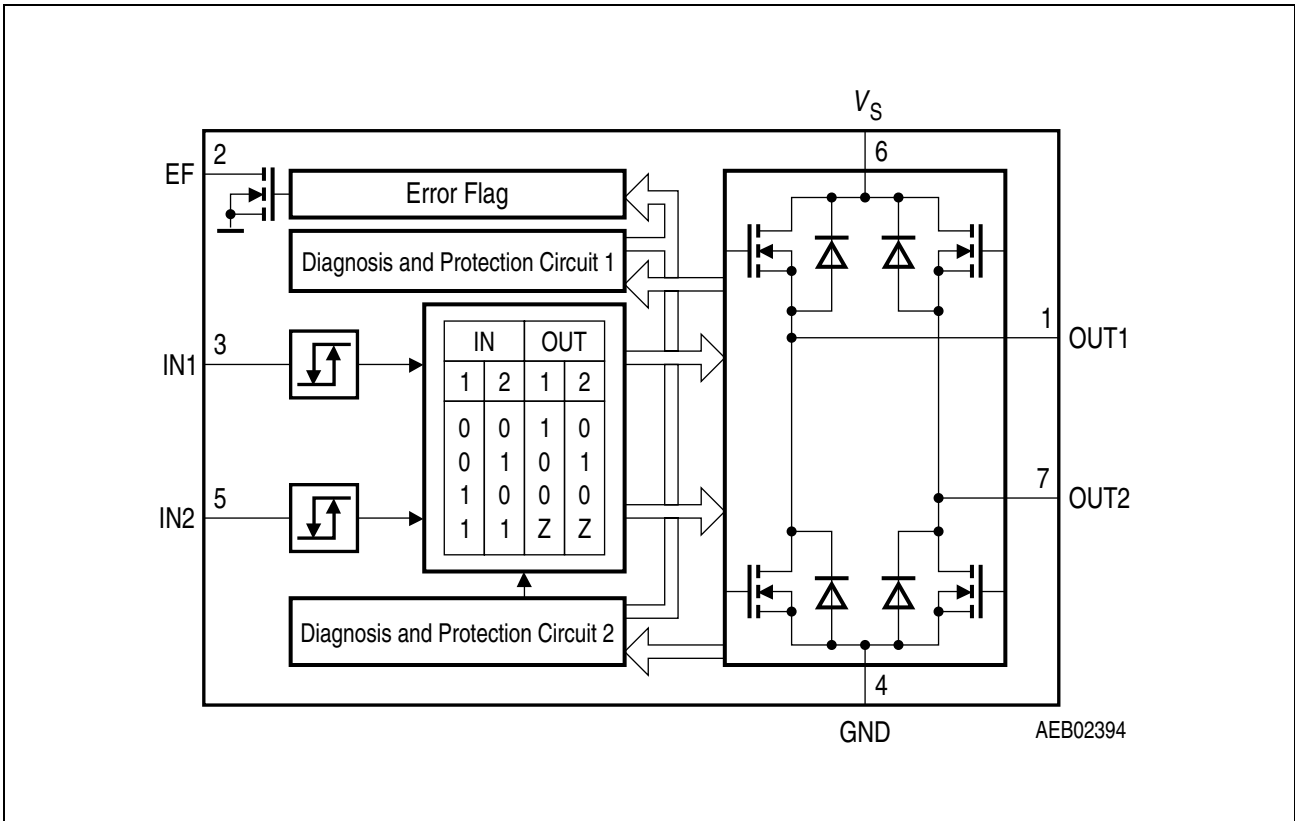

Figure 2 Block Diagram

1.5 Circuit Description

Input Circuit

The control inputs consist of TTL/CMOS-compatible schmitt-triggers with hysteresis. Buffer amplifiers are driven by this stages.

Output Stages

The output stages consist of a DMOS H-bridge. Integrated circuits protect the outputs against short-circuit to ground and to the supply voltage. Positive and negative voltage spikes, which occur when switching inductive loads, are limited by integrated freewheeling diodes.

A monitoring circuit for each output transistor detects whether the particular transistor is active and in this case prevents the corresponding source transistor (sink transistor) from conducting in sink operation (source operation). Therefore no crossover currents can occur.

1.6 Input Logic Truth Table

Functional Truth Table

IN1	IN2	OUT1	OUT2	Comments
L	L	H	L	Motor turns clockwise
L	H	L	H	Motor turns counterclockwise
H	L	L	L	Brake; both low side transistors turned-ON
H	H	Z	Z	Open circuit detection

Notes for Output Stage

Symbol	Value
L	Low side transistor is turned-ON High side transistor is turned-OFF
H	High side transistor is turned-ON Low side transistor is turned-OFF
Z	High side transistor is turned-OFF Low side transistor is turned-OFF

1.7 Monitoring Functions

Undervoltage lockout (UVLO):

When V_S reaches the switch on voltage $V_{S\text{ ON}}$ the IC becomes active with a hysteresis. All output transistors are switched off if the supply voltage V_S drops below the switch off value $V_{S\text{ OFF}}$.

1.8 Protective Function

Various errors like short-circuit to + V_S , ground or across the load are detected. All faults result in turn-OFF of the output stages after a delay of 50 μs and setting of the error flag EF to ground. Changing the inputs resets the error flag.

a. Output Shorted to Ground Detection

If a high side transistor is switched on and its output is shorted to ground, the output current is internally limited. After a delay of 50 μs all outputs will be switched-OFF and the error flag is set.

b. Output Shorted to + V_S Detection

If a low side transistor is switched on and its output is shorted to the supply voltage, the output current is internally limited. After a delay of 50 μs all outputs will be switched-OFF and the error flag is set.

c. Overload Detection

An internal circuit detects if the current through the low side transistor exceeds the trippoint I_{SDL} . In this case all outputs are turned off after 50 μs and the error flag is set.

d. Overtemperature Protection

At a junction temperature higher than 150 °C the thermal shutdown turns-OFF, all four output stages commonly and the error flag is set with a delay.

e. Open Load Detection

The output Q1 has a 10 k Ω pull-up resistor and the output Q2 has a 10 k Ω pull-down resistor. If E1 and E2 are high, all output power stages are turned-OFF. In case of no load between Q1 and Q2 the output voltage Q1 is V_S and Q2 is ground. This state will be detected by two comparators and an error flag will be set after a delay time of 50 μs . Changing the inputs resets the error flip flop.

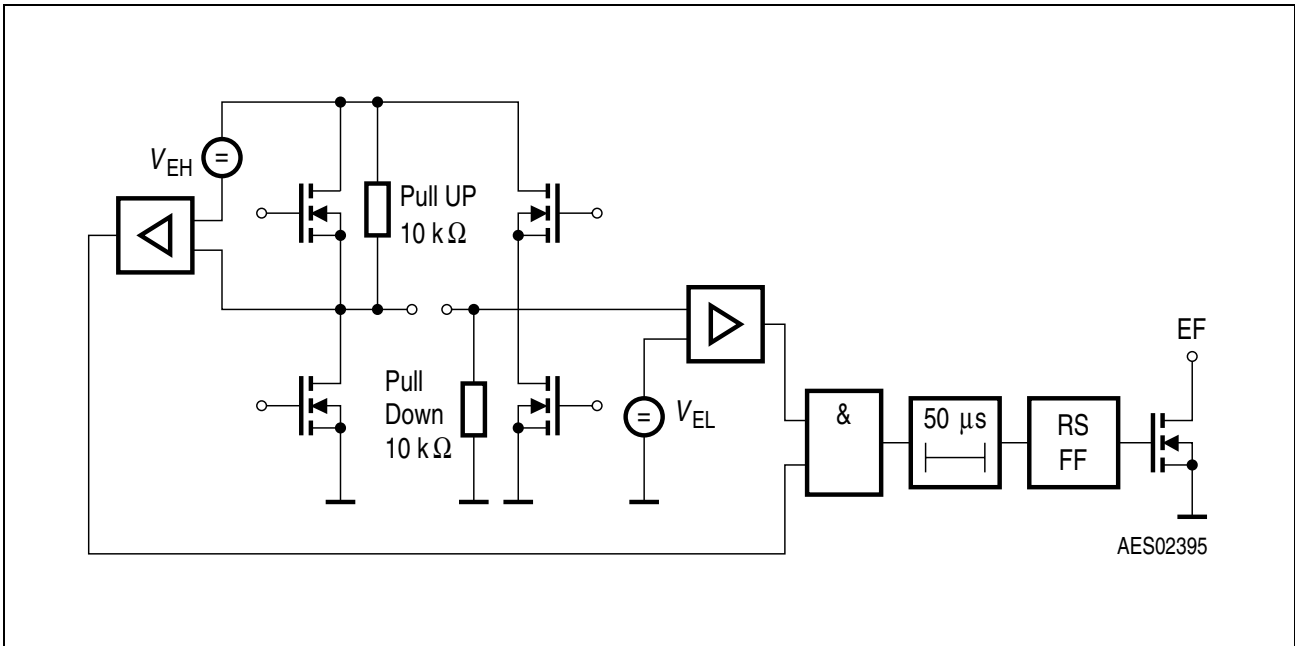

Figure 3 Simplified Schematic for Open Load Detection

Electrical Characteristics
3 Electrical Characteristics
3.1 Absolute Maximum Ratings

$$-40\text{ °C} < T_j < 150\text{ °C}$$

Parameter	Symbol	Limit Values		Unit	Remarks
		min.	max.		

Voltages

Supply voltage	V_S	- 0.3	40	V	-
		- 1	40	V	$t < 0.5\text{ s}; I_S > -5\text{ A}$
Logic input voltage	$V_{IN1,2}$	- 0.3	7	V	$0\text{ V} < V_S < 40\text{ V}$
Diagnostics output voltage	V_{EF}	- 0.3	7	V	-

Currents of DMOS-Transistors and Freewheeling Diodes

Output current (cont.)	$I_{OUT1,2}$	- 5	5	A	-
Output current (peak)	$I_{OUT1,2}$	- 6	6	A	$t_p < 100\text{ ms}; T = 1\text{ s}$
Output current (peak)	$I_{OUT1,2}$	-	-	A	$t_p < 50\text{ }\mu\text{s}; T = 1\text{ s};$ internally limited; see overcurrent

Temperatures

Junction temperature	T_j	- 40	150	°C	-
Storage temperature	T_{stg}	- 50	150	°C	-

Thermal Resistances

Junction case	R_{thjC}	-	3	K/W	P-TO220-7-11/12, P-TO263-7-1
Junction ambient	R_{thjA}	-	65	K/W	P-TO220-7-11/12
		-	75	K/W	P-TO263-7-1
Junction case	R_{thjC}	-	5	K/W	P-DSO-20-12
Junction ambient	R_{thjA}	-	50	K/W	P-DSO-20-12

Note: Maximum ratings are absolute ratings; exceeding any one of these values may cause irreversible damage to the integrated circuit.

Electrical Characteristics
3.2 Operating Range

Parameter	Symbol	Limit Values		Unit	Remarks
		min.	max.		
Supply voltage	V_S	$V_{UV\ ON}$	40	V	After V_S rising above $V_{UV\ ON}$
Supply voltage increasing		- 0.3	$V_{UV\ ON}$	V	Outputs in tristate condition
Supply voltage decreasing		- 0.3	$V_{UV\ OFF}$	V	
Logic input voltage	$V_{IN1,2}$	- 0.3	7	V	-
Junction temperature	T_j	- 40	150	°C	-

3.3 Electrical Characteristics
 $6\ V < V_S < 18\ V$; $IN1 = IN2 = HIGH$
 $I_{OUT1,2} = 0\ A$ (No load); $- 40\ ^\circ C < T_j < 150\ ^\circ C$; unless otherwise specified

Parameter	Symbol	Limit Values			Unit	Test Condition
		min.	typ.	max.		

Current Consumption

Quiescent current	I_S	-	-	10	mA	$IN1 = IN2 = LOW$; $V_S = 13.2\ V$
-------------------	-------	---	---	----	----	--

Under Voltage Lockout

UV-Switch-ON voltage	$V_{UV\ ON}$	-	5.3	6	V	V_S increasing
UV-Switch-OFF voltage	$V_{UV\ OFF}$	3.5	4.7	5.6	V	V_S decreasing
UV-ON/OFF-Hysteresis	$V_{UV\ HY}$	0.2	0.6	-	V	$V_{UV\ ON} - V_{UV\ OFF}$

Electrical Characteristics
3.3 Electrical Characteristics (cont'd)
 $6\text{ V} < V_S < 18\text{ V}; \text{IN1} = \text{IN2} = \text{HIGH}$
 $I_{\text{OUT1,2}} = 0\text{ A (No load)}; -40\text{ }^\circ\text{C} < T_j < 150\text{ }^\circ\text{C}; \text{unless otherwise specified}$

Parameter	Symbol	Limit Values			Unit	Test Condition
		min.	typ.	max.		

Outputs OUT1, 2
Static Drain-Source-On Resistance

Source $I_{\text{OUT}} = -3\text{ A}$	$R_{\text{DS ON H}}$	-	220	350	mΩ	$6\text{ V} < V_S < 18\text{ V}$ $T_j = 25\text{ }^\circ\text{C}$
			-	500	mΩ	$6\text{ V} < V_S < 18\text{ V}$
			350	500	mΩ	$V_{\text{S ON}} < V_S \leq 6\text{ V}$ $T_j = 25\text{ }^\circ\text{C}$
			-	800	mΩ	$V_{\text{S ON}} < V_S \leq 6\text{ V}$
Sink $I_{\text{OUT}} = 3\text{ A}$	$R_{\text{DS ON L}}$	-	230	350	mΩ	$6\text{ V} < V_S < 18\text{ V}$ $T_j = 25\text{ }^\circ\text{C}$
			-	500	mΩ	$6\text{ V} < V_S < 18\text{ V}$
			400	600	mΩ	$V_{\text{S ON}} < V_S \leq 6\text{ V}$ $T_j = 25\text{ }^\circ\text{C}$
			-	1000	mΩ	$V_{\text{S ON}} < V_S \leq 6\text{ V}$

Note: Values of $R_{\text{DS ON}}$ for $V_{\text{S ON}} < V_S \leq 6\text{ V}$ are guaranteed by design.

Overcurrent

Source shutdown trippoint	$-I_{\text{SDH}}$	-	-	10	A	$T_j = -40\text{ }^\circ\text{C}$
		-	8	-	A	$T_j = 25\text{ }^\circ\text{C}$
		6	-	-	A	$T_j = 150\text{ }^\circ\text{C}$
Sink shutdown trippoint	I_{SDL}	-	-	10	A	$T_j = -40\text{ }^\circ\text{C}$
		-	8	-	A	$T_j = 25\text{ }^\circ\text{C}$
		6	-	-	A	$T_j = 150\text{ }^\circ\text{C}$
Shutdown delay time	t_{dSD}	25	50	80	μs	-

Electrical Characteristics
3.3 Electrical Characteristics (cont'd)
 $6\text{ V} < V_S < 18\text{ V}; \text{IN1} = \text{IN2} = \text{HIGH}$
 $I_{\text{OUT}1,2} = 0\text{ A (No load)}; -40\text{ }^\circ\text{C} < T_j < 150\text{ }^\circ\text{C}; \text{ unless otherwise specified}$

Parameter	Symbol	Limit Values			Unit	Test Condition
		min.	typ.	max.		

Short Circuit Current Limitation

Source current	$-I_{\text{SCH}}$	–	–	20	A	$t < t_{\text{dSD}}$
Sink current	I_{SCL}	–	–	15	A	$t < t_{\text{dSD}}$

Open Circuit

Pull up resistor	R_{UP}	5	10	20	k Ω	–
Pull down resistor	R_{DOWN}	5	10	20	k Ω	–
Switching threshold H	V_{EH}	2	2.5	3	V	–
Switching threshold L	V_{EL}	2	2.4	3	V	–
Detection delay time	t_{dSD}	25	50	80	μs	–

Output Delay Times (Device Active for $t > 1\text{ ms}$)

Source ON	$t_{\text{d ON H}}$	–	10	20	μs	$I_{\text{OUT}} = -3\text{ A}$ resistive load
Sink ON	$t_{\text{d ON L}}$	–	10	20	μs	$I_{\text{OUT}} = 3\text{ A}$ resistive load
Source OFF	$t_{\text{d OFF H}}$	–	2	5	μs	$I_{\text{OUT}} = -3\text{ A}$ resistive load
Sink OFF	$t_{\text{d OFF L}}$	–	2	5	μs	$I_{\text{OUT}} = 3\text{ A}$ resistive load

Electrical Characteristics
3.3 Electrical Characteristics (cont'd)
 $6\text{ V} < V_S < 18\text{ V}$; IN1 = IN2 = HIGH

 $I_{\text{OUT}1,2} = 0\text{ A}$ (No load); $-40\text{ }^\circ\text{C} < T_j < 150\text{ }^\circ\text{C}$; unless otherwise specified

Parameter	Symbol	Limit Values			Unit	Test Condition
		min.	typ.	max.		

Output Switching Times (Device Active for $t > 1\text{ ms}$)

Source ON	$t_{\text{ON H}}$	–	15	30	μs	$I_{\text{OUT}} = -3\text{ A}$ resistive load
Sink ON	$t_{\text{ON L}}$	–	5	10	μs	$I_{\text{OUT}} = 3\text{ A}$ resistive load
Source OFF	$t_{\text{OFF H}}$	–	2	5	μs	$I_{\text{OUT}} = -3\text{ A}$ resistive load
Sink OFF	$t_{\text{OFF L}}$	–	2	5	μs	$I_{\text{OUT}} = 3\text{ A}$ resistive load

Clamp Diodes
Forward Voltage

High-side	V_{FH}	–	1	1.5	V	$I_F = 3\text{ A}$
Low-side	V_{FL}	–	1.1	1.5	V	$I_F = 3\text{ A}$

Leakage Current

Source	I_{LKH}	– 100	– 50	–	μA	OUT1 = V_S
Sink	I_{LKL}	–	50	100	μA	OUT2 = GND

Logic
Control Inputs IN 1, 2

H-input voltage threshold	V_{INH}	2.8	2.5	–	V	–
L-input voltage	V_{INL}	–	1.7	1.2	V	–
Hysteresis of input voltage	V_{INHY}	0.4	0.8	1.2	V	–
H-input current	I_{INH}	– 2	0	2	μA	$V_{\text{IN}} = 5\text{ V}$
L-input current	I_{INL}	– 10	– 4	0	μA	$V_{\text{IN}} = 0\text{ V}$

Electrical Characteristics
3.3 Electrical Characteristics (cont'd)
 $6\text{ V} < V_S < 18\text{ V}$; IN1 = IN2 = HIGH

 $I_{\text{OUT}1,2} = 0\text{ A}$ (No load); $-40\text{ }^\circ\text{C} < T_j < 150\text{ }^\circ\text{C}$; unless otherwise specified

Parameter	Symbol	Limit Values			Unit	Test Condition
		min.	typ.	max.		

Error Flag Output EF

Low output voltage	V_{EFL}	–	0.25	0.5	V	$I_{\text{EF}} = 3\text{ mA}$
Leakage current	I_{EFL}	–	–	10	μA	$V_{\text{EF}} = 7\text{ V}$

Thermal Shutdown

Thermal shutdown junction temperature	T_{jSD}	150	175	200	$^\circ\text{C}$	–
Thermal switch-on junction temperature	T_{jSO}	120	–	170	$^\circ\text{C}$	–
Temperature hysteresis	ΔT	–	30	–	K	–
Shutdown delay time	t_{dSD}	25	50	80	μs	–

Note: Values of thermal shutdown are guaranteed by design.

Electrical Characteristics

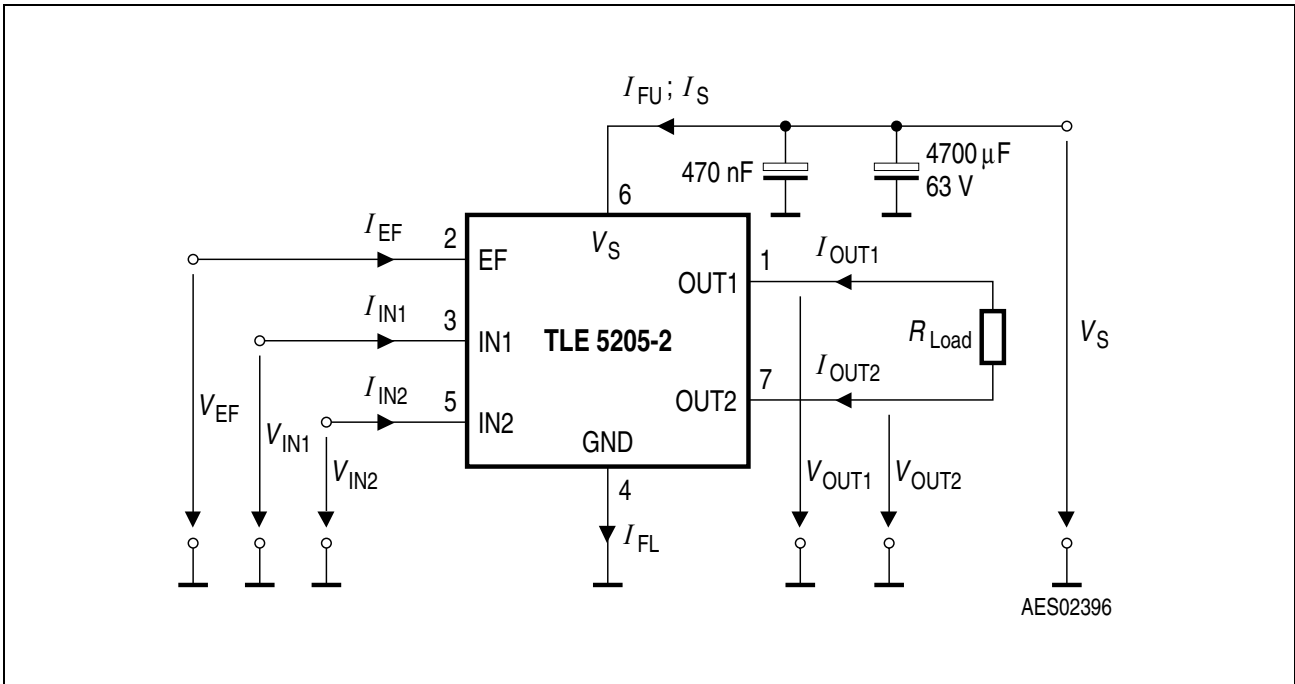

Figure 4 Test Circuit

	Overcurrent	Short Circuit	Open Circuit
I_{OUT}	I_{SD}	I_{SC}	I_{OC}

Electrical Characteristics

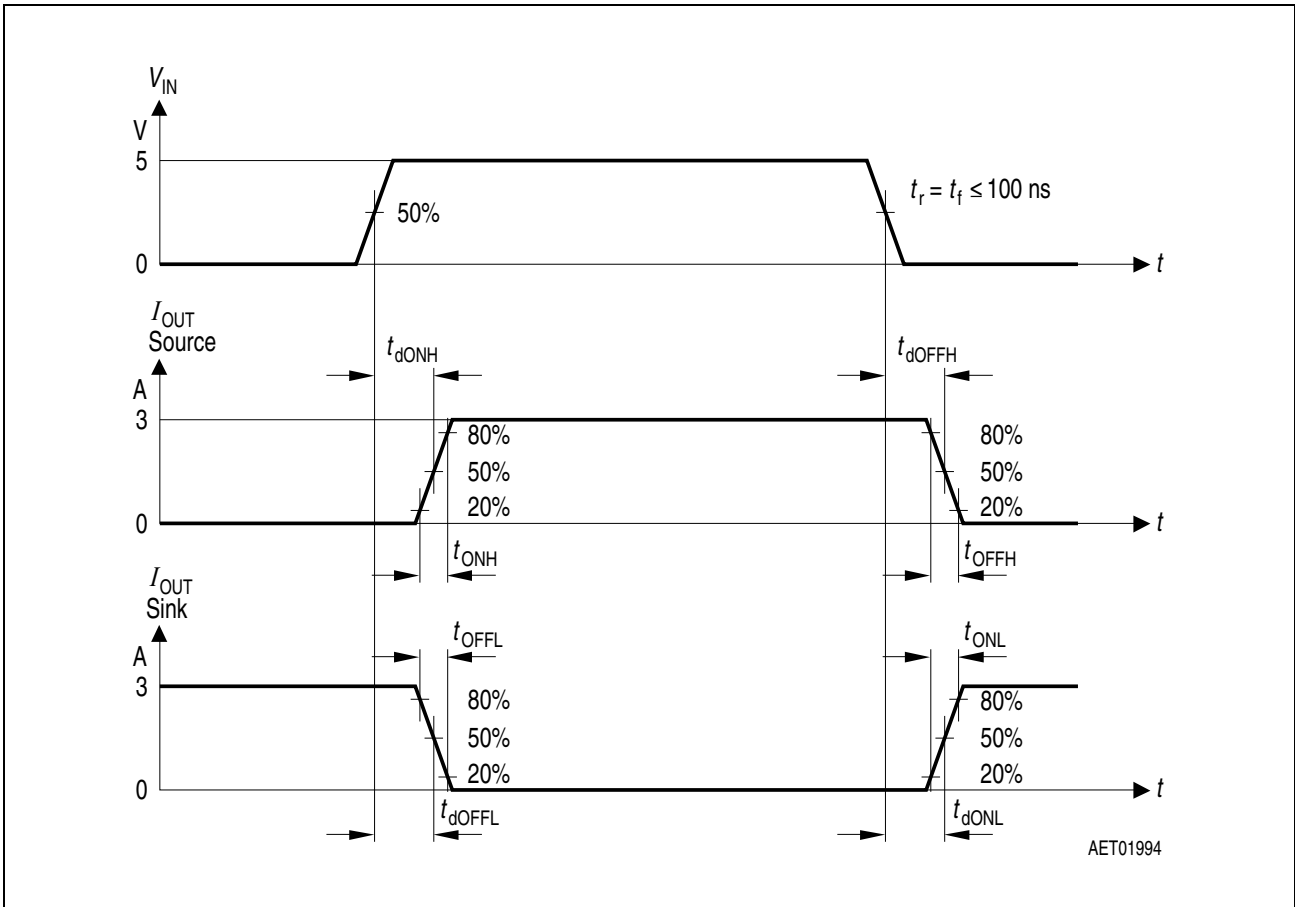

Figure 5 Switching Time Definitions

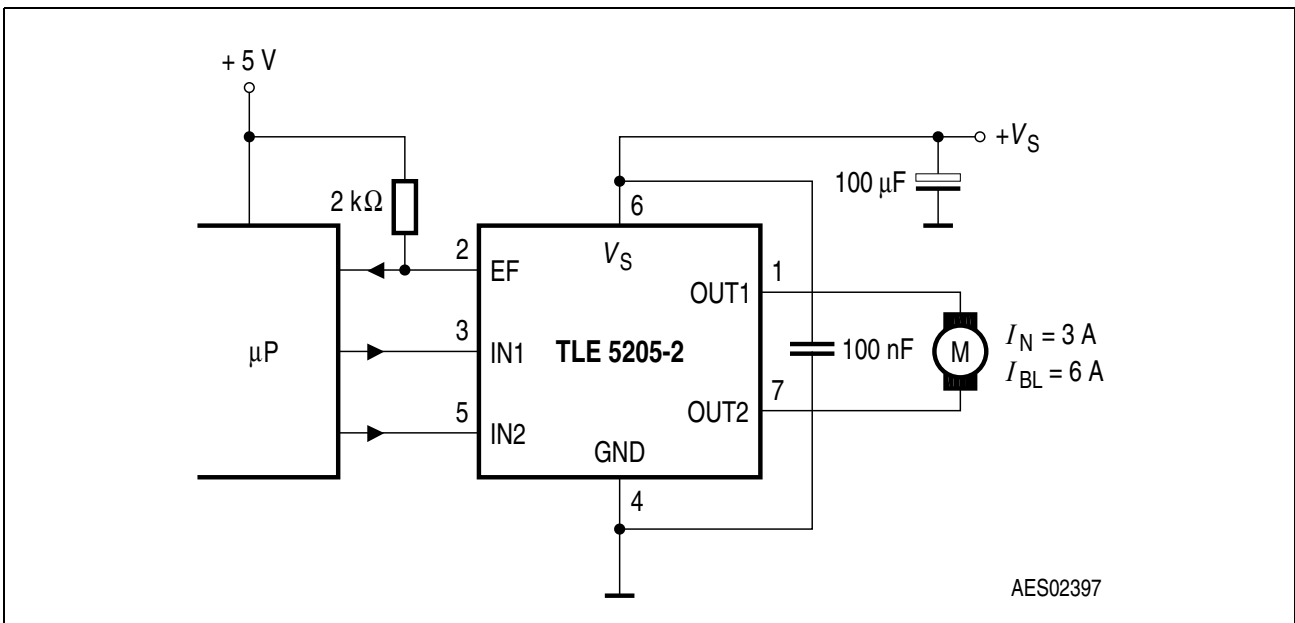

Figure 6 Application Circuit

Electrical Characteristics

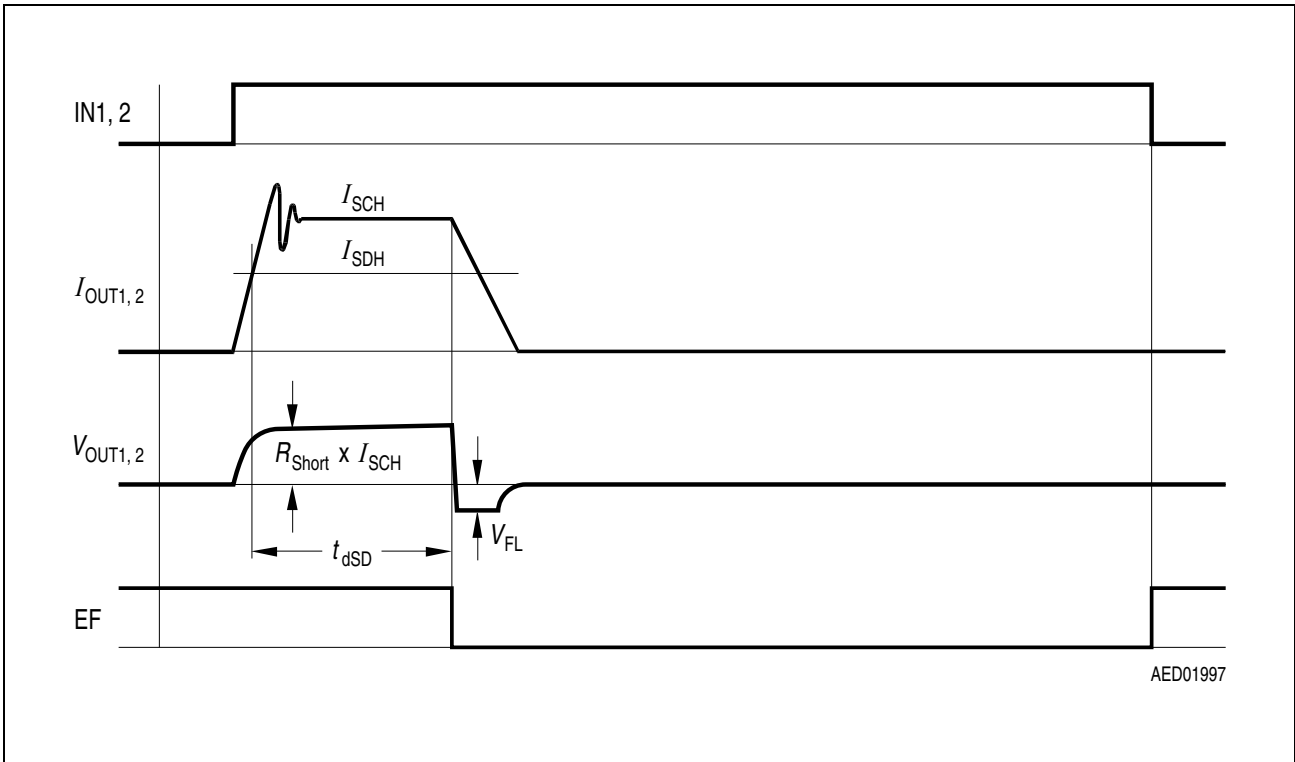

Figure 7 Timing Diagram for Output Shorted to Ground

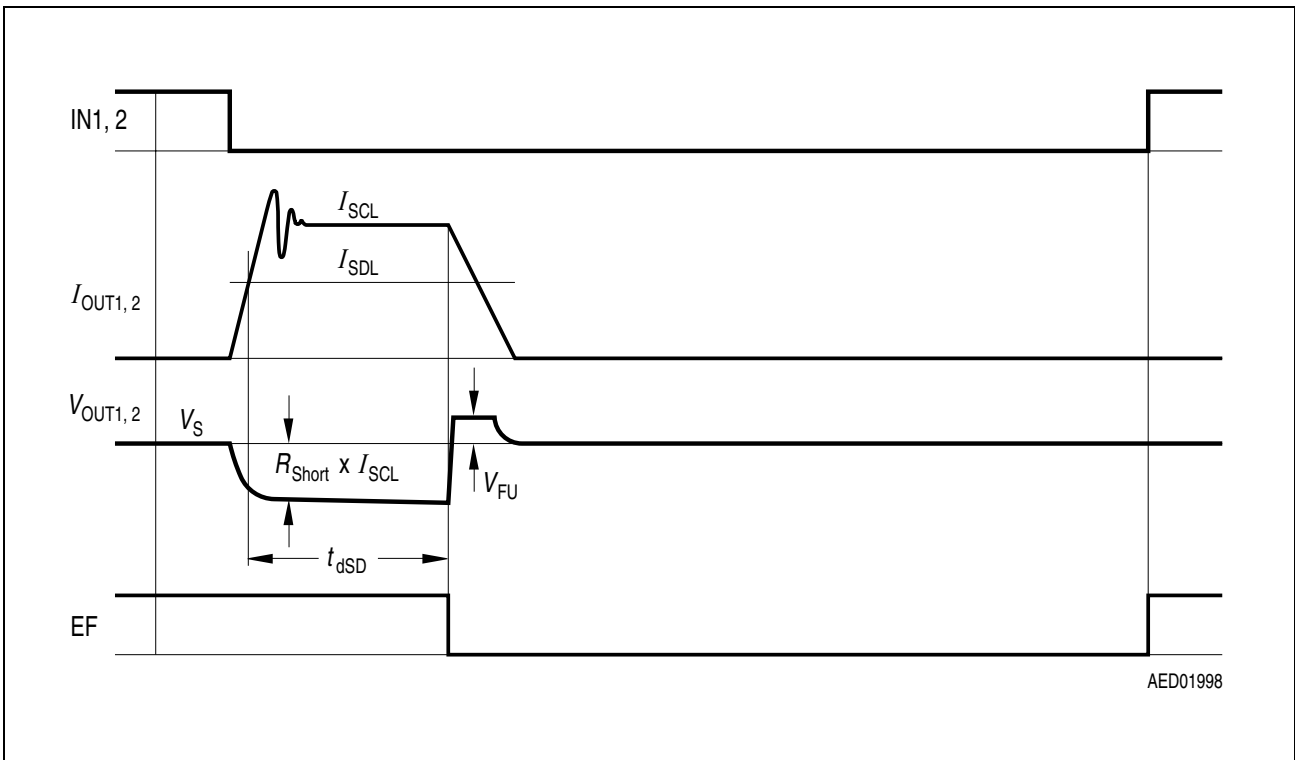
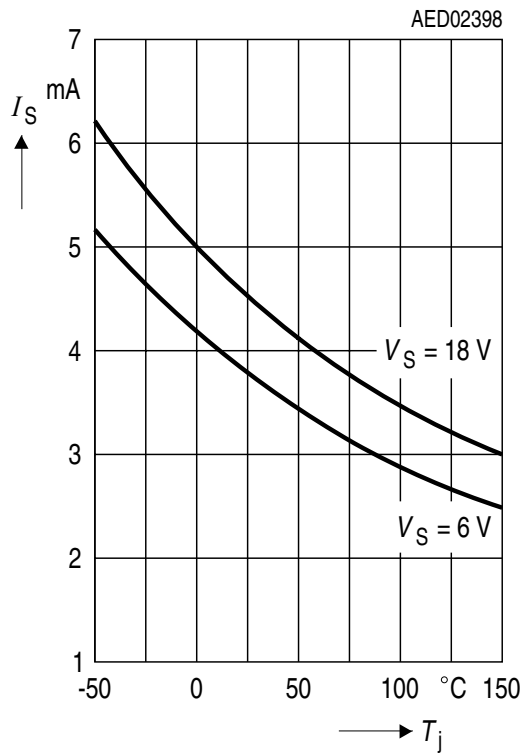

Figure 8 Timing Diagram for Output Shorted to V_S

Electrical Characteristics

Diagrams

Quiescent Current I_S (Active) versus Junction Temperature T_j



Static Drain-Source ON-Resistance versus Junction Temperature T_j

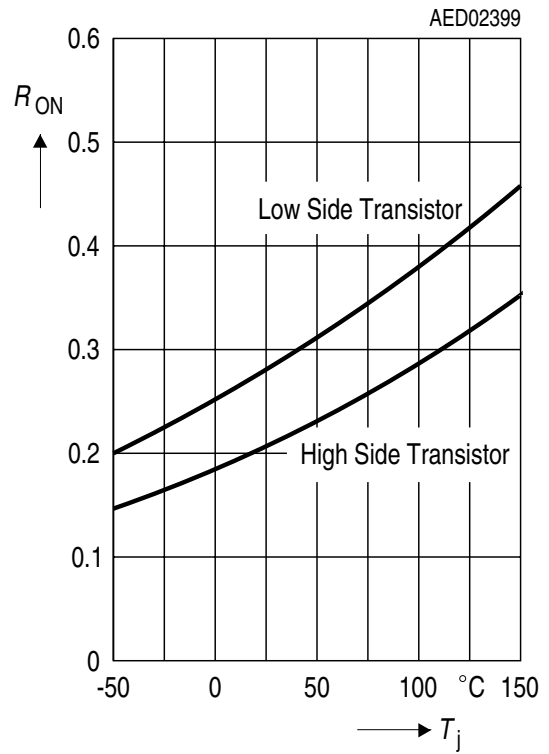

Input Switching Thresholds $V_{INH, L}$ versus Junction Temperature T_j

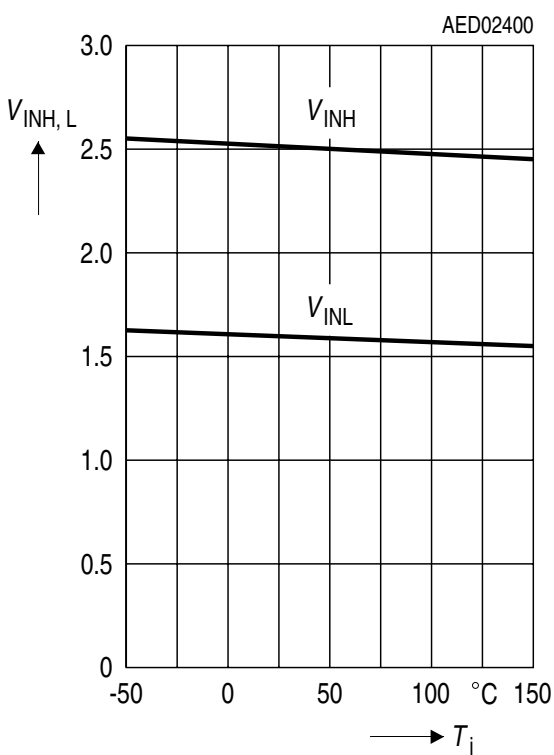

Clamp Diode Forward Voltage V_F versus Junction Temperature T_j

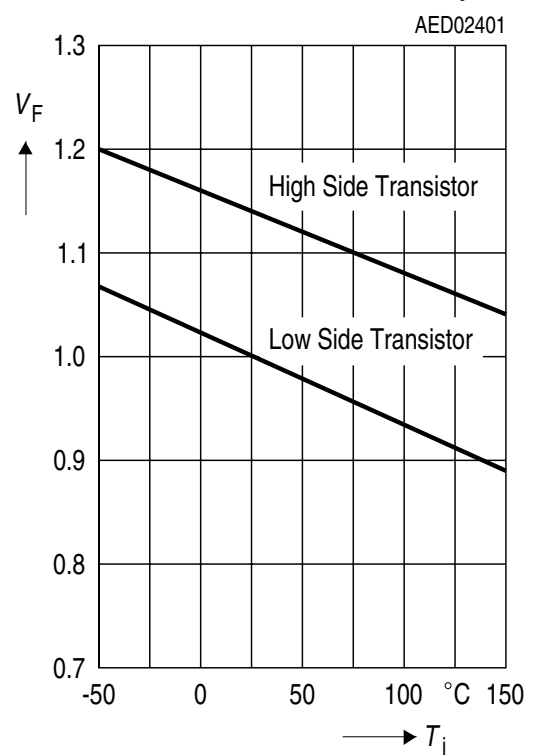

Electrical Characteristics

Overcurrent Shutdown Threshold I_{SD} versus Junction Temperature T_j

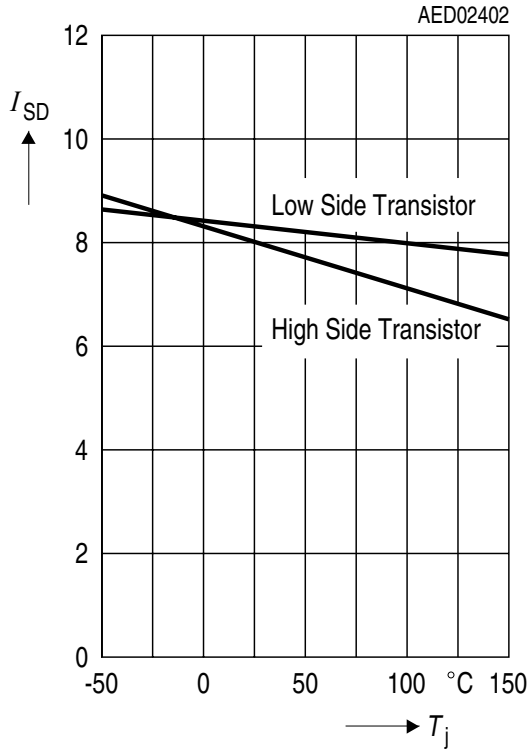

Switching Threshold V_{EH} , V_{EL} versus Junction Temperature T_j

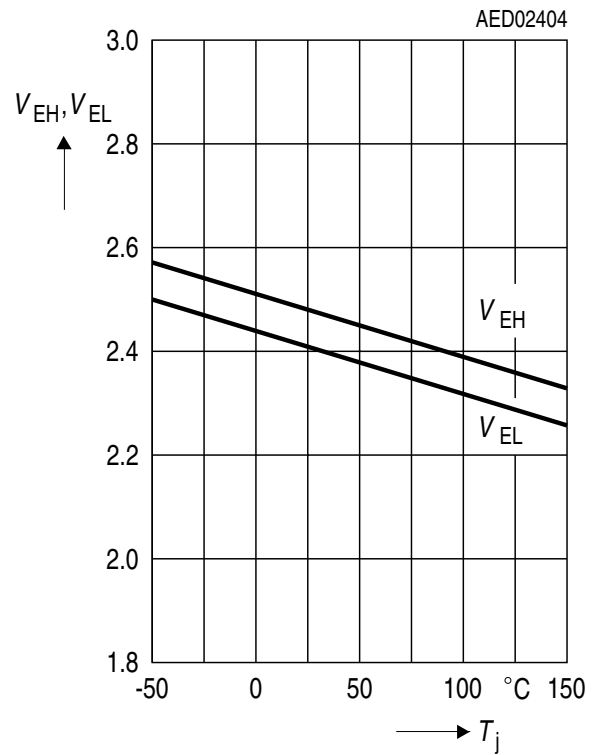

Error-Flag Saturation Output Voltage V_{EF} versus Junction Temperature T_j

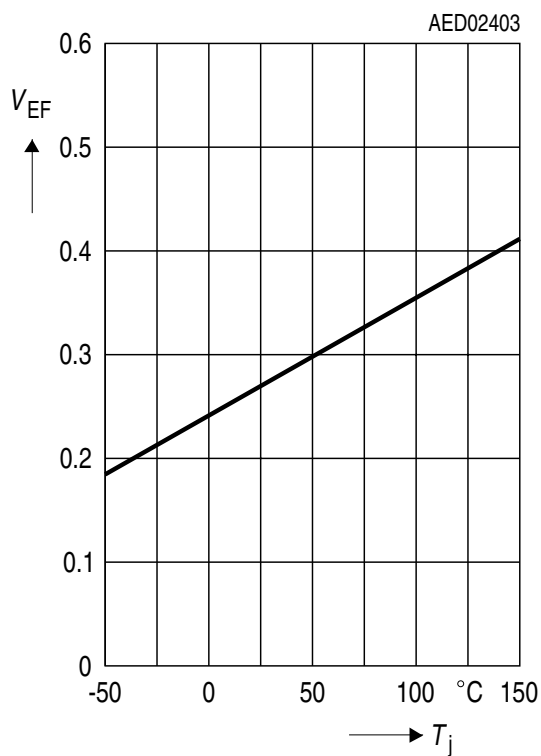

4 Package Outlines

PG-TO220-7-11
(Plastic Transistor Single Outline Package)

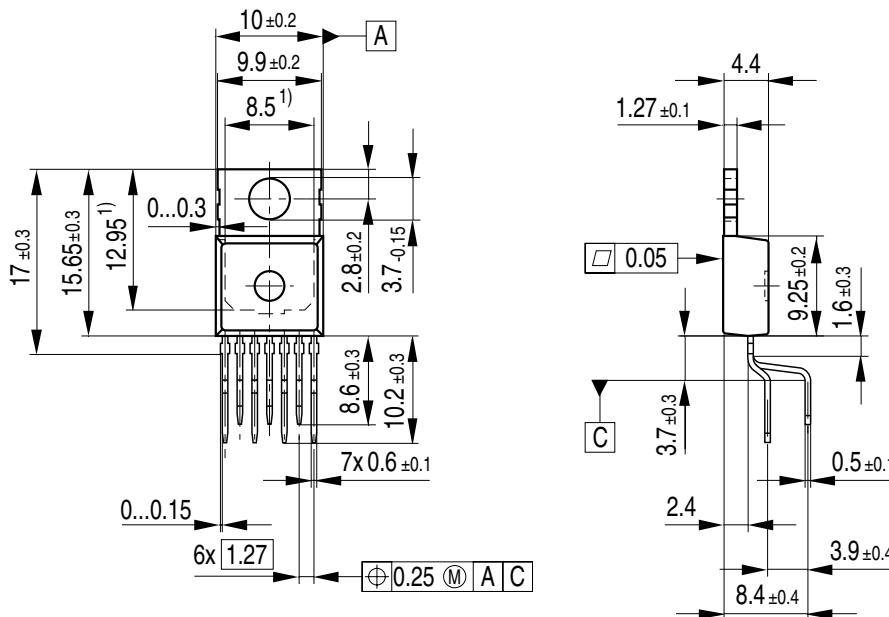

1) Typical
Metal surface min. $X=7.25$, $Y=12.3$
All metal surfaces tin plated, except area of cut.

Green Product (RoHS compliant)

To meet the world-wide customer requirements for environmentally friendly products and to be compliant with government regulations the device is available as a green product. Green products are RoHS-Compliant (i.e Pb-free finish on leads and suitable for Pb-free soldering according to IPC/JEDEC J-STD-020).

You can find all of our packages, sorts of packing and others in our Infineon Internet Page "Products": <http://www.infineon.com/products>.

SMD = Surface Mounted Device

Dimensions in mm

PG-DSO-20-37
(Plastic Dual Small Outline Package)

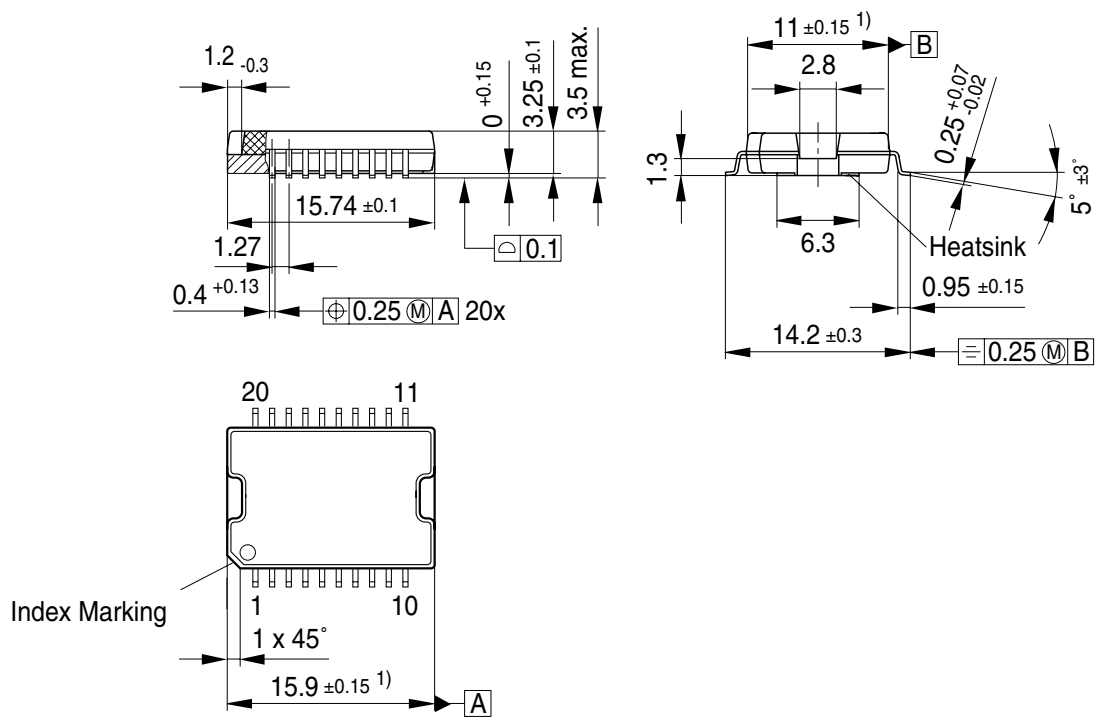

1) Does not include plastic or metal protrusion of 0.15 max. per side

GPS05791

Green Product (RoHS compliant)

To meet the world-wide customer requirements for environmentally friendly products and to be compliant with government regulations the device is available as a green product. Green products are RoHS-Compliant (i.e Pb-free finish on leads and suitable for Pb-free soldering according to IPC/JEDEC J-STD-020).

You can find all of our packages, sorts of packing and others in our Infineon Internet Page "Products": <http://www.infineon.com/products>.

SMD = Surface Mounted Device

Dimensions in mm

PG-TO263-7-1
(Plastic Transistor Single Outline Package)

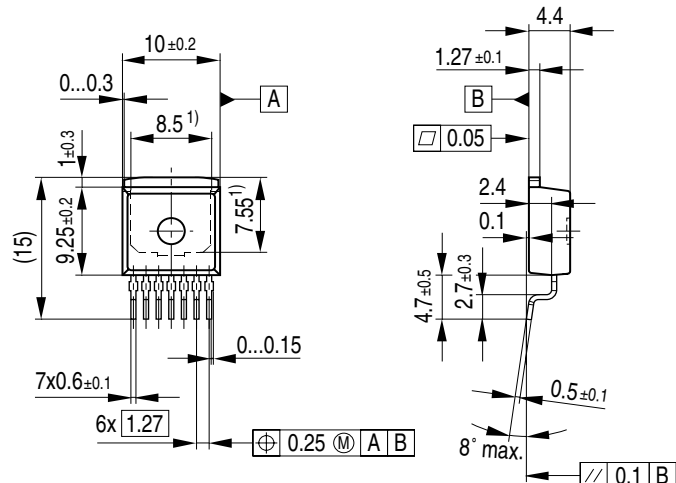

¹⁾ Typical
Metal surface min. X=7.25, Y=6.9
All metal surfaces tin plated, except area of cut.

GPT09114

Green Product (RoHS compliant)

To meet the world-wide customer requirements for environmentally friendly products and to be compliant with government regulations the device is available as a green product. Green products are RoHS-Compliant (i.e Pb-free finish on leads and suitable for Pb-free soldering according to IPC/JEDEC J-STD-020).

You can find all of our packages, sorts of packing and others in our Infineon Internet Page "Products": <http://www.infineon.com/products>.

SMD = Surface Mounted Device

Dimensions in mm

PG-TO220-7-12
(Plastic Transistor Single Outline Package)

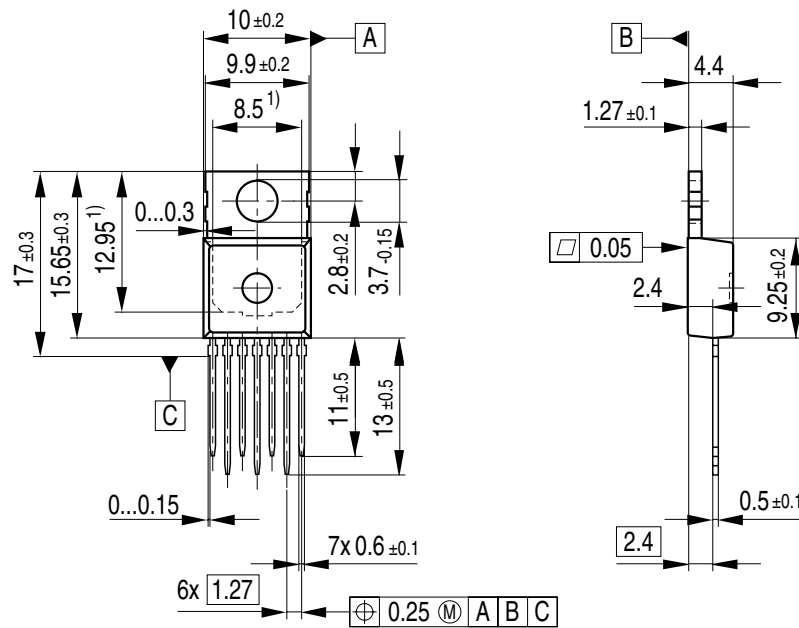

1) Typical
Metal surface min. X=7.25, Y=12.3
All metal surfaces tin plated, except area of cut.

Green Product (RoHS compliant)

To meet the world-wide customer requirements for environmentally friendly products and to be compliant with government regulations the device is available as a green product. Green products are RoHS-Compliant (i.e Pb-free finish on leads and suitable for Pb-free soldering according to IPC/JEDEC J-STD-020).

You can find all of our packages, sorts of packing and others in our Infineon Internet Page "Products": <http://www.infineon.com/products>.

SMD = Surface Mounted Device

Dimensions in mm

5 Revision History

Version	Date	Changes
Rev. 1.1	2007-07-31	<p>RoHS-compliant version of the TLE 5205-2</p> <ul style="list-style-type: none">• All pages: Infineon logo updated• Page 1: “AEC qualified” and “RoHS” logo added, “Green Product (RoHS compliant)” and “AEC qualified” statement added to feature list, package names changed to RoHS compliant versions, package pictures updated, ordering codes removed• Page 20-23: Package names changed to RoHS compliant versions, “Green Product” description added• Revision History added• Legal Disclaimer added

Edition 2007-07-31

**Published by
Infineon Technologies AG
81726 Munich, Germany**

**© 8/1/07 Infineon Technologies AG
All Rights Reserved.**

Legal Disclaimer

The information given in this document shall in no event be regarded as a guarantee of conditions or characteristics. With respect to any examples or hints given herein, any typical values stated herein and/or any information regarding the application of the device, Infineon Technologies hereby disclaims any and all warranties and liabilities of any kind, including without limitation, warranties of non-infringement of intellectual property rights of any third party.

Information

For further information on technology, delivery terms and conditions and prices, please contact the nearest Infineon Technologies Office (www.infineon.com).

Warnings

Due to technical requirements, components may contain dangerous substances. For information on the types in question, please contact the nearest Infineon Technologies Office.

Infineon Technologies components may be used in life-support devices or systems only with the express written approval of Infineon Technologies, if a failure of such components can reasonably be expected to cause the failure of that life-support device or system or to affect the safety or effectiveness of that device or system. Life support devices or systems are intended to be implanted in the human body or to support and/or maintain and sustain and/or protect human life. If they fail, it is reasonable to assume that the health of the user or other persons may be endangered.

Looking for pricing, stock, or lifecycle information?

Click below to explore more details on WIN SOURCE:

- ⊖ [View TLE52052SAKSA1 on WIN SOURCE](#)
- ⊖ [Infineon Technologies Information](#)

Optimize Your Supply Chain with WIN SOURCE Solutions

- ✓ Global Sourcing Solution
- ✓ Obsolete Management
- ✓ Cost Control Management
- ✓ Shortage Management
- ✓ Alternative Solution
- ✓ Excess Inventory Management