



THE DATASHEET OF LM3432MHX/NOPB



6-Channel Current Regulator for LED Backlight Application

Check for Samples: [LM3432](#), [LM3432B](#)

FEATURES

- **Dynamic Headroom Control (DHC) Output to Maximize Efficiency when used in Conjunction with Texas Instruments Semiconductor's LM3430 Boost Controller for LED Backlighting**
- **Current Sinking Adjustable up to 40mA in Each String**
- **Fast Current Switching Slew Rate, $t_r = 60\text{ns}$ Typical**
- **Wide Dimming Ratio, up to 4000:1 with $f_{\text{DIM}} = 500\text{Hz}$**
- **High LED Driving Voltage up to 80V**
- **$\pm 2.0\%$ Current Matching Between Strings**
- **Accepts Both Digital and Analog Dimming Control**
- **LED Open/Short Fault Indication (For LM3432B, no open fault indication)**
- **Over-Temperature Indication**
- **Internal Thermal Shutdown with Hysteresis**

- **Low profile, Thermally Enhanced WQFN-24 (5x4x0.8mm) and eHTSSOP-28 (9.7x6.4x1.1mm) Packages (The LM3432B is available in the WQFN-24 only)**

APPLICATIONS

- **LCD Display Backlight Applications**
- **General Lighting Solutions**

DESCRIPTION

The LM3432/LM3432B are 6-channel high voltage current regulators which provide a simple solution for LED backlight applications. These devices incorporate six individual current regulator channels to give accurate driving current for each LED string. The string-to-string tolerance is kept within $\pm 2.0\%$. Additionally, the Dynamic Headroom Control output can communicate with a LM3430 boost regulator to adjust the LED supply voltage to the lowest level needed to keep the string current in regulation, yielding optimal overall system efficiency.

TYPICAL APPLICATION CIRCUIT

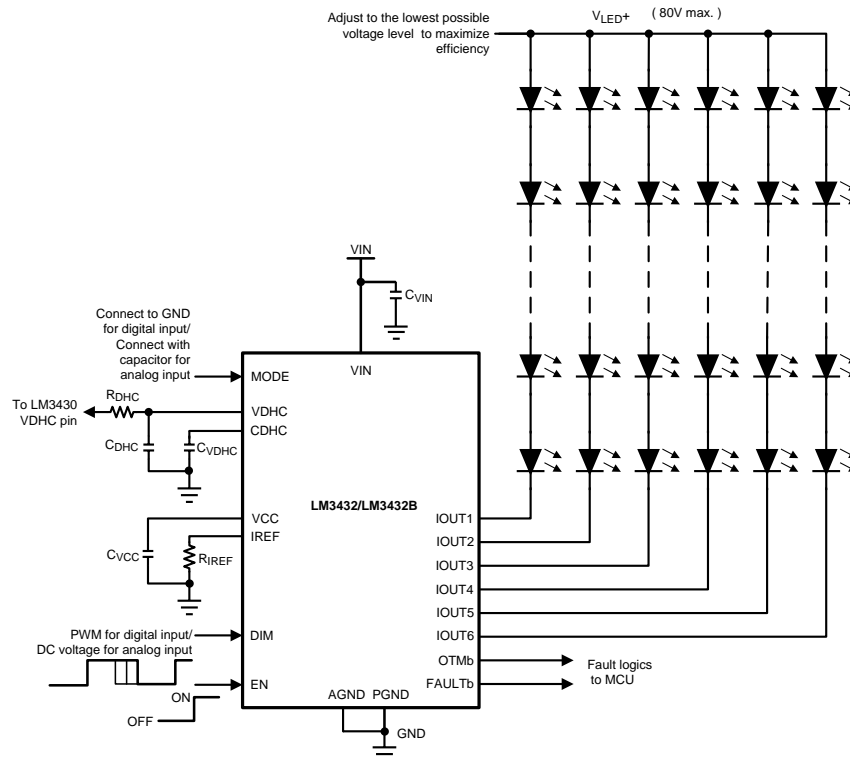

Please be aware that an important notice concerning availability, standard warranty, and use in critical applications of Texas Instruments semiconductor products and disclaimers thereto appears at the end of this data sheet.

All trademarks are the property of their respective owners.

DESCRIPTION CONTINUED

The 6-channel current sink can be adjusted from 15mA to 40mA by an external resistor. Their output drivers can withstand up to 80V. Digital PWM or analog voltage signal can be used to control the duty cycle of all the channels. With a fast current switching slew rate, $t_r = 60\text{ns}$ typical, accurate current control and wide dimming ratio during PWM dimming are ensured.

The LM3432/LM3432B contain LED open/short circuit and over-temperature fault signaling to the system micro-controller (the LM3432B does not include open circuit fault signaling). These devices are available in a low profile, thermally enhanced 24 lead WQFN package. The LM3432 is also available in the 28 lead eHTSSOP.

Connection Diagram

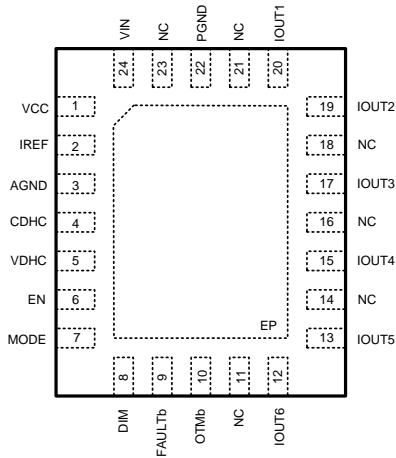

Figure 1. Top View
24 Lead Plastic WQFN-24

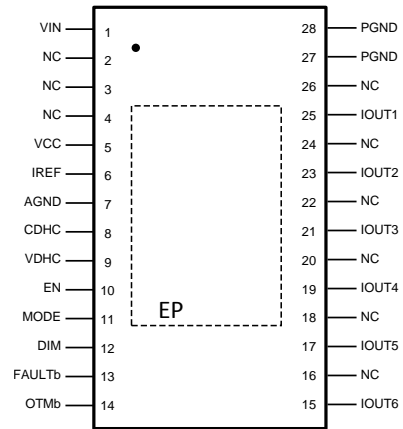

Figure 2. Top View
28 Lead Plastic eHTSSOP-28

Pin Descriptions

Pin Number		Name	Description
WQFN-24	eHTSSOP-28		
1	5	VCC	Internal linear regulator output, needs 680nF minimum for stability.
2	6	IREF	I_{OUT} current setting pin. An external resistor is used to program the string current.
3	7	AGND	Analog ground
4	8	CDHC	An external capacitor to ground programs the Dynamic Headroom Control (DHC) response time constant.
5	9	VDHC	DHC voltage output. Connecting this output through a gain setting resistor to the DHC pin of Texas Instruments Semiconductor's LM3430 enables the DHC function.
6	10	EN	Device Enable, active HIGH.
7	11	MODE	Dimming mode select pin. Short to ground for Digital PWM dimming or connect to an external capacitor to ground for analog dimming.
8	12	DIM	Digital PWM or Analog voltage input for IOUT duty cycle.
9	13	FAULTb	Open drain active LOW output for output fault.
10	14	OTMb	Open drain active LOW over temperature warning output.
12, 13, 15, 17, 19, 20	15, 17, 19, 21, 23, 25	IOUT1-6	Constant current sink outputs, adjustable 15mA to 40mA, voltage across this pin can be up to 80V max.
22	27, 28	PGND	Power Ground.
24	1	VIN	Supply voltage input, from 6V to 40V.
11, 14, 16, 18, 21, 23	2, 3, 4, 16, 18, 20, 22, 24, 26	NC	No connection and should be left open.
EP	EP	EP	Thermal connection pad, connect directly to GND.



These devices have limited built-in ESD protection. The leads should be shorted together or the device placed in conductive foam during storage or handling to prevent electrostatic damage to the MOS gates.

ABSOLUTE MAXIMUM RATINGS ^{(1) (2)}

If Military/Aerospace specified devices are required, contact the Texas Instruments Sales Office/ Distributors for availability and specifications.

		VALUE / UNIT
VIN Voltage		-0.3V to 42V
IREF Voltage		-0.3V to 7V
IOUT1 through IOUT6 Voltage		-0.3V to 82V
VCC Voltage		-0.3V to 7V
EN Voltage		-0.3V to 7V
FAULTb, OTMb Voltage		-0.3V to 7V
MODE Voltage		-0.3V to 7V
PWM Voltage		-0.3V to 7V
VDHC Voltage		-0.3V to 7V
CDHC Voltage		-0.3V to 7V
ESD Susceptibility	Human Body Model ⁽³⁾	2.0kV
Lead Temperature	Vapor Phase (60 sec.)	215°C
	Infra-red (15 sec.)	220°C
Maximum Junction Temperature		150°C

- (1) Absolute Maximum Ratings are limits beyond which damage to the device may occur. The Recommended Operating Limits define the conditions within which the device is intended to be functional. For specifications and test conditions, see the Electrical Characteristics.
- (2) Rating limits apply to both the LM3432 and LM3432B.
- (3) The human body model is a 100 pF capacitor discharged through a 1.5kΩ resistor into each pin.

RECOMMENDED OPERATING CONDITIONS ⁽¹⁾

		VALUE / UNIT
Supply Voltage, VIN		6 to 40V
IOUT1 through IOUT6 Voltage		0 to 80V
Operating Junction Temp.		-40°C to +125°C
Storage Temperature		-65°C to +150°C
Thermal Resistance, θ_{JA} ⁽²⁾	WQFN-24	33.2°C/W
	eHTSSOP-28	29°C/W

- (1) Absolute Maximum Ratings are limits beyond which damage to the device may occur. The Recommended Operating Limits define the conditions within which the device is intended to be functional. For specifications and test conditions, see the Electrical Characteristics.
- (2) The maximum allowable power dissipation is a function of the maximum junction temperature, T_{J_MAX} , the junction-to-ambient thermal resistance, θ_{JA} and the ambient temperature, T_A . The maximum allowable power dissipation at any ambient temperature is calculated using: $P_{D_MAX} = (T_{J_MAX} - T_A) / \theta_{JA}$. Exceeding the maximum allowable power dissipation will cause excessive die temperature.

ELECTRICAL CHARACTERISTICS

Limits in standard type are for $T_J = 25^\circ\text{C}$ only; limits in **boldface type** apply over the junction temperature (T_J) range of -40°C to $+125^\circ\text{C}$. Minimum and Maximum limits are specified through test, design, or statistical correlation. $V_{IN} = 18\text{V}$, $R_{REF} = 54.7\text{ k}\Omega$, $V_{EN} = 5\text{V}$, $V_{MODE} = 0\text{V}$, $V_{DIM} = 5\text{V}$ and $V_{OUT1-6} = 1.2\text{V}$ unless otherwise indicated ⁽¹⁾. Parameter limits apply to both the LM3432 and LM3432B unless otherwise indicated.

Symbol	Parameter	Conditions	Min	Typ	Max	Units
Input Characteristics						
I_{SHDN}	Shutdown Input Supply Current	$EN = 0\text{V}$, $DIM = 0\text{V}$		40	90	μA
I_Q	Quiescent Current from V_{IN}			2.25	2.65	mA
V_{EN}	Enable Threshold Voltage	V_{EN} rising	1.48	1.75	2	V
V_{EN_HYST}	Enable Threshold Hysteresis			0.4		V
I_{EN}	Enable pin Pull-up Current	$EN = 0\text{V}$		0.5		μA
		$EN = 2\text{V}$		5		
VCC Regulator						
V_{CCreg}	VCC Regulated Output		4.7	5	5.25	V
V_{CCreg_1}	VCC Regulated Output at Max. V_{IN}	$V_{IN} = 40\text{V}$	4.7	5	5.25	V
V_{CCreg_2}	VCC Regulated Output at Min. V_{IN}	$V_{IN} = 6\text{V}$, $I_{VCC} = 2\text{mA}$		4.8		V
I_{VCC_SC}	VCC Short-Circuit Current	$V_{IN} = 6\text{V}$, $V_{CC} = 0\text{V}$		9		mA
V_{CCUVLO}	VCC UVLO Upper Threshold	VCC rising	3.9	4.15	4.4	V
V_{CCUVLO_HYST}	VCC UVLO Hysteresis			0.375		V
Analog PWM control						
I_{MODE}	MODE pin Output Current	MODE = 2V		34		μA
V_{MODE_PK}	MODE pin Peak Voltage	$C_{MODE} = 5.6\text{nF}$		3.1		V
V_{MODE_VA}	MODE pin Valley Voltage	$C_{MODE} = 5.6\text{nF}$		1.0		V
Digital PWM control						
V_{PWM_HIGH}	PWM Voltage HIGH	MODE = GND	1.7			V
V_{PWM_LOW}	PWM Voltage LOW	MODE = GND			1	V
Dynamic Headroom Control Output						
V_{DHC_MAX}	VDHC pin Max. Output Voltage	$I_{VDHC} = 2\text{mA}$	2	2.5		V
I_{VDHC_MAX}	VDHC pin Max. Output Current	$V_{DHC} = 1.2\text{V}$	5	9		mA
$V_{DHC_REG_20}$	VDHC Regulation at 20mA	$R_{REF} = 54.7\text{k}$, $C_{DHC} = 100\text{nF}$		0.625		V
$V_{DHC_REG_40}$	VDHC Regulation at 40mA	$R_{REF} = 27.5\text{k}$, $C_{DHC} = 100\text{nF}$		1.25		V
Switching Characteristics						
t_{pd_H}	IOUT Rising Edge Phase Delay	MODE = GND, Pulsing PWM 10 μs		500		ns
T_r	IOUT Rise Time	MODE = GND, rising edge from 10% to 90% of IOUT		25		ns
Output Current						
V_{IREF}	IREF pin Voltage	$6\text{V} \leq V_{IN} \leq 40\text{V}$	1.215	1.245	1.27	V
I_{OUT20}	Constant Current Sink of 20mA	$R_{REF} = 54.7\text{k}$, $V_{IOUT1-6} = 1.1\text{V}$	18.85 18.5	20	21.05 21.4	mA
I_{OUT40}	Constant Current Sink of 40mA	$R_{REF} = 27.5\text{k}$, $V_{IOUT1-6} = 1.6\text{V}$	37.9 37.3	40	41.55 42.15	mA
I_{OUT20_match}	Output Current Matching of I_{OUT20} ⁽²⁾	$6\text{V} \leq V_{IN} \leq 40\text{V}$			2.25	%

(1) All limits are specified at room temperature (standard type face) and at **temperature extremes (bold type face)**. All room temperature limits are 100% tested. All limits at **temperature extremes** are ensured via correlation using standard Statistical Quality Control (SQC) methods. All limits are used to calculate Average Outgoing Quality Level (AOQL). Typical values represent the most likely parametric norm at $T_J = 25^\circ\text{C}$ and are provided for reference purposes only.

(2) I_{OUT_match} is the greatest percentage delta between output string currents with respect to the median.

$$I_{OUT_match} = \frac{1}{2} \left(\frac{\text{Max}(I_{OUTx}) - \text{Min}(I_{OUTx})}{\text{Median}} \right) \times 100\% \text{ and}$$

$$\text{Median} = \frac{\text{Max}(I_{OUTx}) + \text{Min}(I_{OUTx})}{2}$$

ELECTRICAL CHARACTERISTICS (continued)

Limits in standard type are for $T_J = 25^\circ\text{C}$ only; limits in **boldface type** apply over the junction temperature (T_J) range of -40°C to $+125^\circ\text{C}$. Minimum and Maximum limits are specified through test, design, or statistical correlation. $V_{IN} = 18\text{V}$, $R_{REF} = 54.7\text{ k}\Omega$, $V_{EN} = 5\text{V}$, $V_{MODE} = 0\text{V}$, $V_{DIM} = 5\text{V}$ and $V_{OUT1-6} = 1.2\text{V}$ unless otherwise indicated ⁽¹⁾. Parameter limits apply to both the LM3432 and LM3432B unless otherwise indicated.

Symbol	Parameter	Conditions	Min	Typ	Max	Units
I_{OUT40_match}	Output Current Matching of I_{OUT40} ⁽²⁾	$6\text{V} \leq V_{IN} \leq 40\text{V}$			2	%
I_{OUT_max}	Maximum Output Current, IREF shorted to GND.	$V_{IREF} = 0\text{V}$, $V_{IOUT} = 4.5\text{V}$	50	80	110	mA
$V_{DROPOUT20}$	Dropout Voltage of I_{OUT20} ⁽³⁾	$R_{IREF} = 54.7\text{k}$		0.3	0.525	V
$V_{DROPOUT40}$	Dropout Voltage of I_{OUT40} ⁽³⁾	$R_{IREF} = 27.5\text{k}$		0.6	1.125	V
I_{OUT_OFF}	Output Current when EN is LOW	$EN = 0$, $V_{OUT} = 80\text{V}$		0.025	3	μA
Fault Detection						
$V_{SHORTFAULT}$	V_{IOUT} Short Fault Threshold	FAULTb goes LOW during V_{IOUT} rising, Other $V_{IOUT^s} = 1.0\text{V}$	7.3	7.9	8.8	V
$t_{D_SHORTFAULT}$	Short Fault Delay	V_{IOUT} set to 10V, FAULTb goes LOW, Other $V_{IOUT^s} = 1.0\text{V}$		150		μs
$t_{D_OPENFAULT}$	Open Fault Delay (LM3432 only)	V_{IOUTX} set open, FAULTb goes LOW		50		μs
V_{FAULT_LOW}	FAULTb and OTMb LOW	5mA into FAULTb			0.7	V
I_{LEAK_FAULT}	FAULTb and OTMb Open Leakage	$V_{FAULTb} = V_{OTMb} = 5\text{V}$		0.005	1	μA
Thermal Protection						
OTM	Over Temperature Monitor Threshold			125		$^\circ\text{C}$
OTM_{HYST}	Over Temperature Monitor Hysteresis			20		$^\circ\text{C}$
T_{SD}	Thermal Shutdown Threshold			165		$^\circ\text{C}$
T_{SDHYST}	Thermal Shutdown Hysteresis			20		$^\circ\text{C}$

(3) Dropout voltage is defined as the IOUT pin to GND voltage at which the output current sink drops 10% from the nominal value.

TYPICAL PERFORMANCE CHARACTERISTICS

Unless otherwise specified, the following conditions apply: $V_{IN} = 18V$, $R_{IREF} = 54.7\text{ k}\Omega$, $V_{EN} = 5V$, $V_{MODE} = 0V$, $V_{DIM} = 5V$ and $V_{OUT1-6} = 1.2V$. Typical performance characteristics are valid for both the LM3432 and LM3432B unless otherwise indicated.

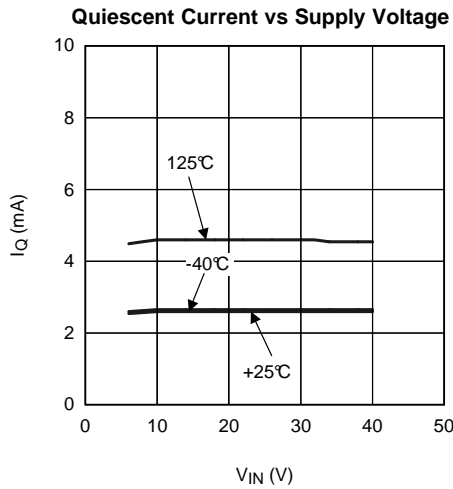

Figure 3.

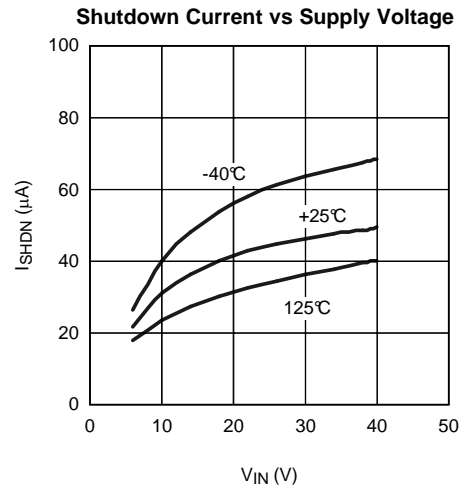

Figure 4.

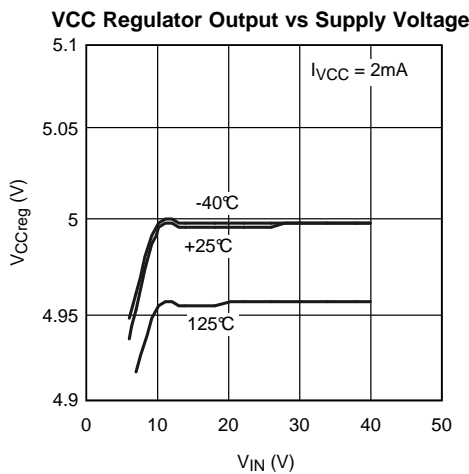

Figure 5.

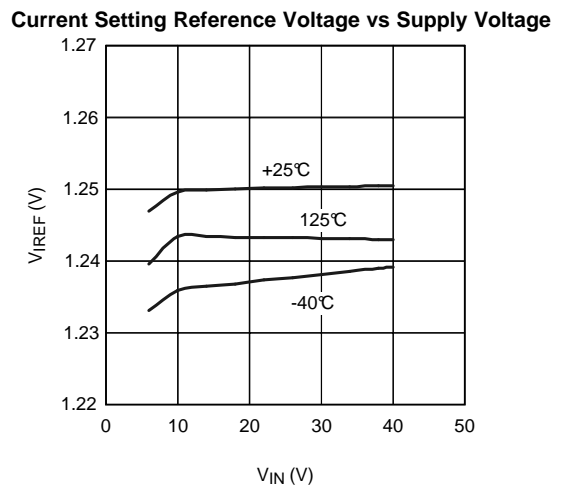

Figure 6.

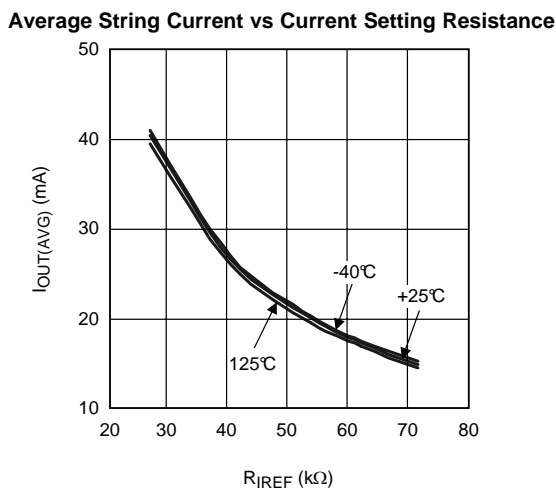

Figure 7.

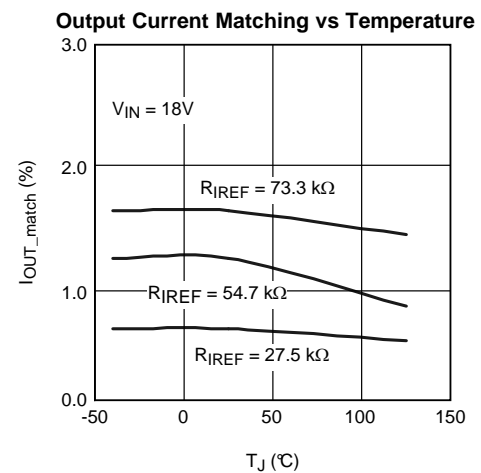

Figure 8.

TYPICAL PERFORMANCE CHARACTERISTICS (continued)

Unless otherwise specified, the following conditions apply: $V_{IN} = 18V$, $R_{REF} = 54.7\text{ k}\Omega$, $V_{EN} = 5V$, $V_{MODE} = 0V$, $V_{DIM} = 5V$ and $V_{OUT1-6} = 1.2V$. Typical performance characteristics are valid for both the LM3432 and LM3432B unless otherwise indicated.

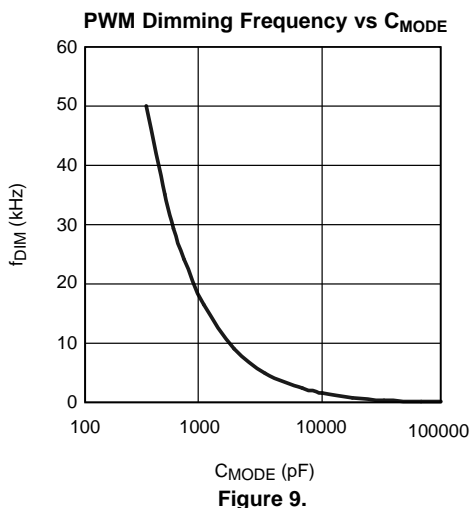

Figure 9.

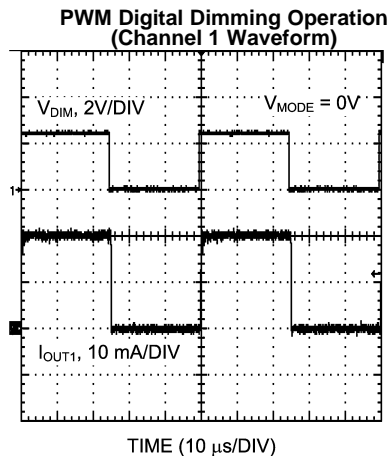

Figure 10.

PWM Dimming Characteristic, Rising Edge (Channel 1 Waveform)

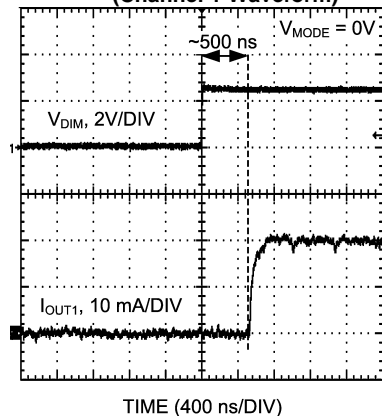

Figure 11.

PWM Dimming Characteristic, Falling Edge (Channel 1 Waveform)

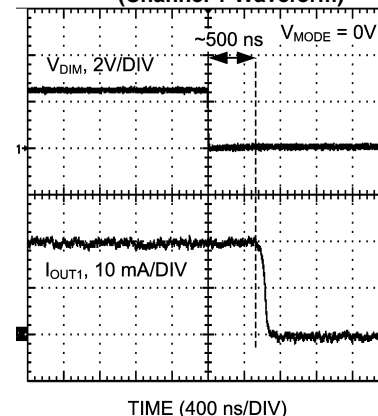

Figure 12.

Analog Dimming Operation

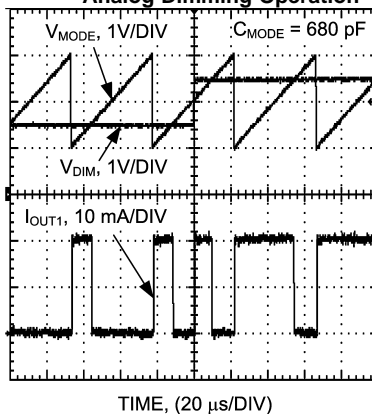
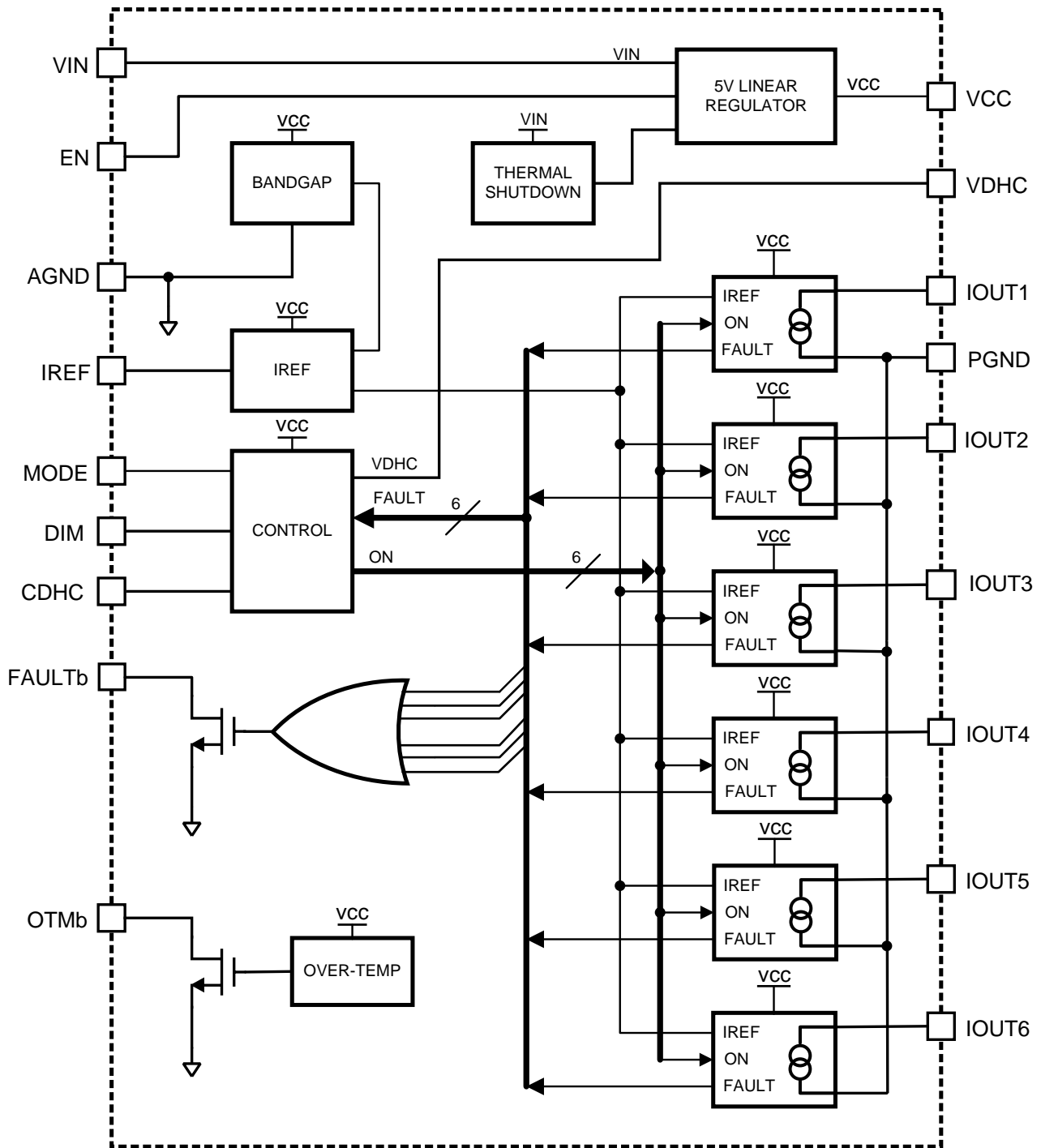

Figure 13.

SIMPLIFIED FUNCTIONAL BLOCK DIAGRAM



FUNCTIONAL DESCRIPTION

OVERVIEW

The LM3432/LM3432B are 6-channel high voltage current regulators for LED backlight applications which incorporates individual channel current regulators to give accurate current sinking for each LED string. String to string tolerance is kept within $\pm 2.0\%$ at 40 mA and $\pm 2.25\%$ at 20 mA. The 6-channels current sinks can be adjusted from 15 mA to 40 mA by an external resistor. Channel outputs can withstand up to 80V. Channel 5 or 6 output can be disabled by shorting the selected output pin to ground prior to power-up. Both the digital PWM dimming signal and analog voltage signal can be used to control the duty cycle of all the six channels. The LM3432/LM3432B also provide fault indications to the system MCU for an LED open (included in the LM3432 only) or short circuit or an over-temperature condition.

INTERNAL 5V LINEAR REGULATOR

An internal 5V linear regulator with an Under-Voltage Lock-Out (UVLO) function is integrated within the LM3432/LM3432B. This regulated 5V is used for internal circuitry and can support a small amount of external loading, not to exceed 2 mA when $V_{IN} = 6V$. The supply input pin (V_{IN}) can be connected directly to an input voltage up to 40V, with transient capability up to 42V. The VCC output regulates at 5V and is current limited to 9 mA. To ensure stable operation, the external capacitor C_{VCC} must be at least 680 nF with 1 μF recommended. If the voltage at the VCC pin drops below the UVLO threshold of 3.8V, the device will shut down the output channels and other functional blocks. Normal operation will be resumed once the V_{CC} voltage is allowed to rise above the UVLO rising threshold of 4.15V.

BANDGAP VOLTAGE REFERENCE

A precision reference voltage is required for accurate control of the output currents. The LM3432/LM3432B contain a bandgap voltage reference block that provides a high precision reference voltage for internal operation. The bandgap reference voltage is typically trimmed to 1.245V.

OUTPUT CURRENT REGULATOR (IOUT1 to IOUT6)

The LM3432/LM3432B contains six individual integrated current regulators to give accurate current sinking for each LED string. String to string tolerance is kept within $\pm 2.0\%$ at 40 mA and $\pm 2.25\%$ at 20 mA. The sink current level is adjusted by an external resistor, R_{IREF} in the range of 15 mA to 40 mA. The IOUT pins can withstand up to 80V. The ability to withstand high voltage enables the user to add more LEDs in a single string. The calculation of I_{OUT} with respect to R_{IREF} is shown below.

$$I_{OUT} = \frac{1.094}{R_{IREF}} \times 10^6 \text{ where } I_{OUT} \text{ is in mA} \quad (1)$$

Channels 5 and 6 are designed to be user disabled without activating the fault detection circuitry. With this feature, the user can readily configure the device to a 4, 5 or 6 channel driver. In order to disable a channel, the IOUT5 and/or IOUT6 pin(s) must be tied to ground before powering up the device. During power-up, channels 5 and 6 will be checked and any grounded channel(s) will be automatically disabled. The disabled status will remain until either power is recycled or the enable (EN) pin is toggled.

ANALOG DIMMING OF LED STRINGS

Dimming of LED brightness is achieved by Pulse Width Modulation (PWM) control of the string currents. The LM3432/LM3432B accepts both analog voltage and PWM digital dimming input signals for this feature. With a capacitor (C_{MODE}) connected across the MODE pin and ground, the device will monitor the voltage level at the DIM pin and generate the required PWM control signal internally. The internal implementation of the LM3432/LM3432B's dimming function is illustrated in [Figure 14](#).

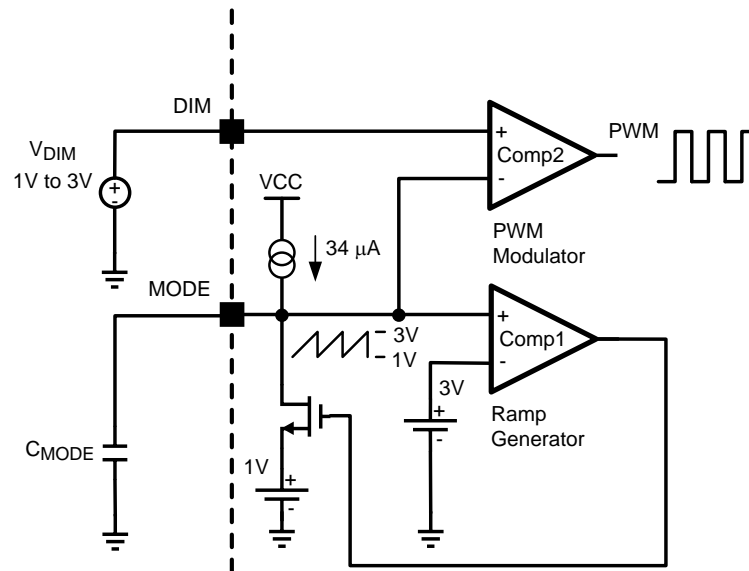

Figure 14. Analog Dimming of LEDs

An internal current source of 34 μA (typical) will charge the external capacitor (C_{MODE}) linearly until it reaches 3V. The comparator (Comp1) then forces C_{MODE} to be discharged to 1V very quickly. By repeating the cycle, a saw-tooth waveform as shown in Figure 14 is generated. Comparator (Comp2) compares this ramp waveform with the external dc voltage at the DIM pin generating the desired PWM control signal.

When $V_{\text{DIM}} \leq 1\text{V}$, $D_{\text{ON}} = 0\%$ and when $V_{\text{DIM}} \geq 3\text{V}$, $D_{\text{ON}} = 100\%$. The frequency of the PWM control signal can be calculated as shown below.

$$f_{\text{PWM}} = \frac{1.65 \times 10^{-5}}{C_{\text{MODE}}} \text{ where } f_{\text{PWM}} \text{ is in Hz} \quad (2)$$

Or

$$C_{\text{MODE}} = \frac{1.65 \times 10^{-5}}{f_{\text{PWM}}} \text{ where } C_{\text{MODE}} \text{ is in Farads} \quad (3)$$

PWM DIGITAL DIMMING of LED STRINGS

Alternatively, the dimming control can be implemented by direct application of a digital signal to the device. With the MODE pin connected to ground, an externally applied PWM dimming signal is applied to the DIM pin. The peak amplitude of the externally applied PWM signal should be greater than 1.5V to ensure clean PWM switching.

During PWM dimming, channels are not switched simultaneously in an effort to minimize large surge currents from being drawn from the LED supply rail. Each channel will have 0.5 μs phase delay with respect to the preceding channel. As a consequence of the phase delay, for a control pulse width less than 0.5 μs , the duty cycle will be rounded down to 0% and for a control pulse width less than 0.5 μs , the duty cycle will be rounded up to 100%. Therefore, 0.5 μs becomes the finest pulse width resolution that can be realized. The PWM switching timing for all six channels is shown in Figure 15.

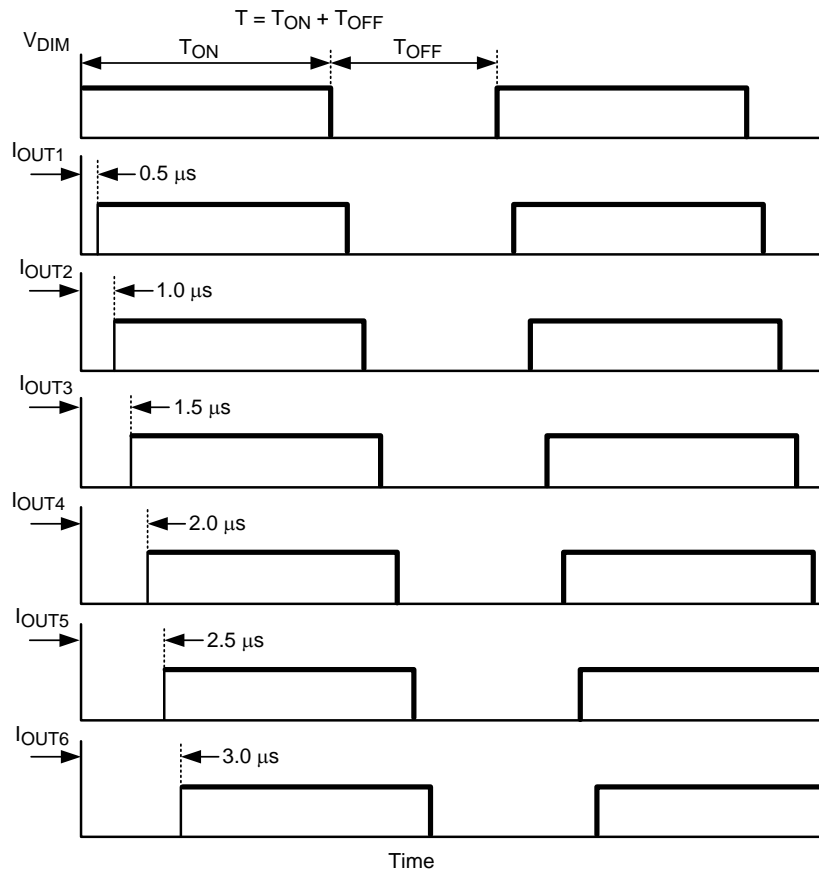

Figure 15. PWM Dimming Switching Timing

LED SHORT FAULT DETECT

With DHC

If the Dynamic Headroom Control (DHC) feature is used, the lowest voltage between the IOUT pins and ground among the strings will be regulated to 0.625V typical ($I_{LED} = 20 \text{ mA}$) by lowering the LED supply rail voltage, V_{LED} . If an LED short fault condition occurs and causes the voltage between any of the IOUT pins and ground to exceed the typical short fault threshold of 7.9V for more than 150 μs , the affected channel(s) will be latched off and the FAULTb pin will be pulled to ground. The affected channel(s) will remain latched off until recycling power or toggling the EN pin. All of the other channels that are not affected will continue to function normally.

Without DHC

In applications where the DHC function is not used, the IOUT pin voltage on each string will be the voltage difference between the LED supply rail voltage, V_{LED} , and the voltage drop across the entire LED string. If the voltage between any of the IOUT pins and ground is less than 2V typical, the short fault detect feature will be active for all channels. In the event an LED short fault condition occurs and causes the voltage between any of the IOUT pin and ground to exceed the typical short fault threshold of 7.9V for more than 150 μs , the affected channel(s) will be latched off and the FAULTb pin will be pulled to ground. The affected channel(s) will remain latched off until recycling power or toggling the EN pin. All of the other channels that are not affected will continue to function normally. If the voltages between all IOUT pins and ground are greater than 2V typical, the Short Fault Detect feature will be disabled to prevent false triggering of the short fault detect function.

DYNAMIC HEADROOM CONTROL

To use the DHC function, connect a gain setting resistor from the VDHC pin of the LM3432/LM3432B to the VDHC pin of the LM3430 (Texas Instruments Semiconductor's Boost Controller for LED Backlighting) that is supplying power to the LED rails. The LM3432/LM3432B's DHC function will regulate the voltage between the IOUT pins and ground to a minimum of 0.625V typical (IOUT = 20 mA) to optimize overall efficiency. A large DHC time constant needs to be set in order not to interfere with the loop response of the DC-DC converter. This can be implemented by connecting a capacitor from the LM3432/LM3432B's CDHC pin to ground. If the DHC function is not needed, leave the VDHC pin floating. When operated in this manner, if the lowest voltage between any of the IOUT pins and ground is greater than 2V, the LED short fault detection function will be disabled. For the LM3432B, if any open condition occurs on any channels, the DHC function will be inactive and the LED supply rail voltage from the LM3430 will stay at its preset level. If the excess headroom voltage is greater than the short fault detect threshold, 7.3V(min), the device may latch off the LED string(s) due to short fault protection. In order to insure the proper operation of good LED strings, designers must design for sufficient excess headroom voltage below the short fault detect threshold.

APPLICATIONS INFORMATION

The LM3432/LM3432B provide a simple and handy solution for LED driving. With only a few external passive components, an LED panel of up to about 120 white LEDs can be illuminated. A typical application configuration driving six strings with twelve white LEDs per string is shown in [Figure 17](#).

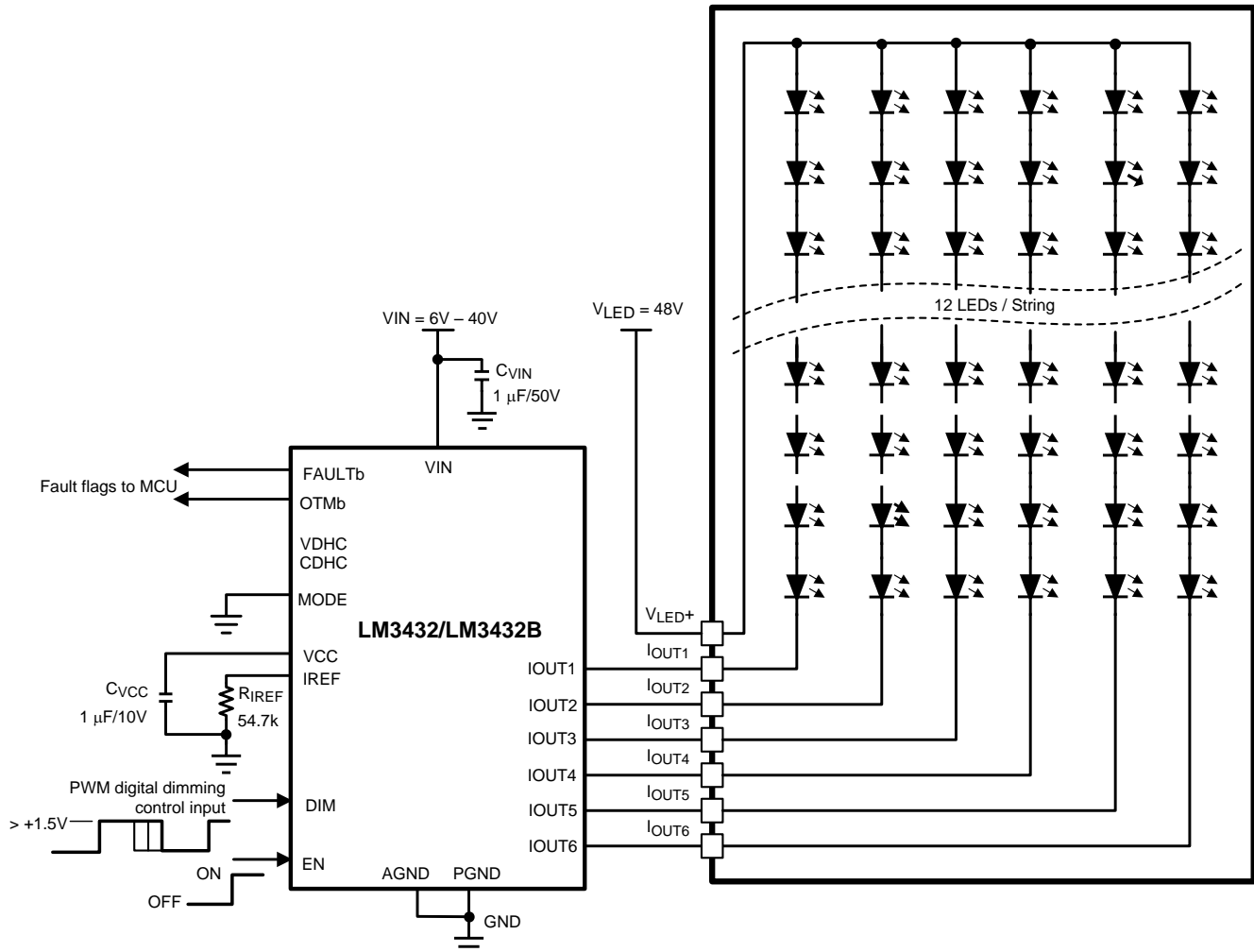

Figure 17. Typical Application Schematic to Drive 72 White LEDs (@20 mA) (PWM Digital Dimming)

DETERMINATION OF EXTERNAL COMPONENTS

The typical application only requires three external components. The selection of those components is described in detail below.

Programming of String Current, IOUT1 to IOUT6

The string current can be programmed by an external resistor, R_{IREF} . The equation to calculate the resistance of this resistor is shown below.

$$R_{IREF} = \frac{1.094}{I_{OUT}} \text{ in k}\Omega \quad (4)$$

In order to ensure good current regulation over the full operating temperature range, a high quality resistor with $\pm 1\%$ tolerance and a low temperature coefficient is recommended.

For the example shown in [Figure 17](#), the string current is 20 mA. Applying to the equation:

$$R_{IREF} = \frac{1.094}{20 \text{ mA}} = 54.7 \text{ k}\Omega \quad (5)$$

Selecting the VCC Output Capacitor, C_{VCC}

For proper operation, a VCC output capacitor (C_{VCC}) of at least 680 nF is required for stability reason. The recommended C_{VCC} capacitance is 1 μ F.

Selecting the VIN Capacitor, C_{VIN}

The purpose of this capacitor is to supply transient current to the device and suppress VIN noise in order to ensure proper operation. A low ESR ceramic capacitor with good high frequency performance is recommended. The capacitance can range from 0.1 μ F to 1 μ F.

Analog Dimming Control

If analog dimming control is required, a capacitor, C_{MODE} should be connected from the MODE pin to ground instead of shorting the MODE pin to ground. The relationship between the PWM dimming frequency and the capacitance of C_{MODE} is illustrated below.

$$f_{PWM} = \frac{1.65 \times 10^{-5}}{C_{MODE}} \text{ where } C_{MODE} \text{ is in Farads and } f_{PWM} \text{ is in Hz} \quad (6)$$

When $V_{PWM} \leq 1V$, $D_{ON} = 0\%$ and when $V_{PWM} \geq 3V$, $D_{ON} = 100\%$

The LED dimming ratio is calculated from the ratio of minimum ON duty factor to the maximum ON duty factor. With the LM3432/LM3432B, the LEDs can be fully turned on up to 100% ON duty factor and the minimum ON duty factor is limited by the phase delay time, 0.5 μ s. The dimming ratio can be estimated as below.

$$\text{Dimming Ratio} = \frac{1}{5 \times 10^{-7} f_{PWM}} : 1 \quad (7)$$

As an example, if the PWM dimming frequency is set to 500 Hz, the best achievable dimming ratio is:

$$\text{Dimming Ratio (} f_{PWM} = 500 \text{ Hz)} = \frac{1}{5 \times 10^{-7} \times 500} : 1 = 4000 : 1 \quad (8)$$

Driving High Current LEDs

The LM3432/LM3432B can support string currents from 15 mA to 40 mA. If the application needs to drive high current LEDs that require more than 40 mA per string, the LM3432/LM3432B provides the alternative of connecting several IOUT ports together to achieve higher output current per string. With this approach, there is the obvious trade off between higher output current and number of strings driven. Two possible configurations are illustrated in [Figure 18](#).

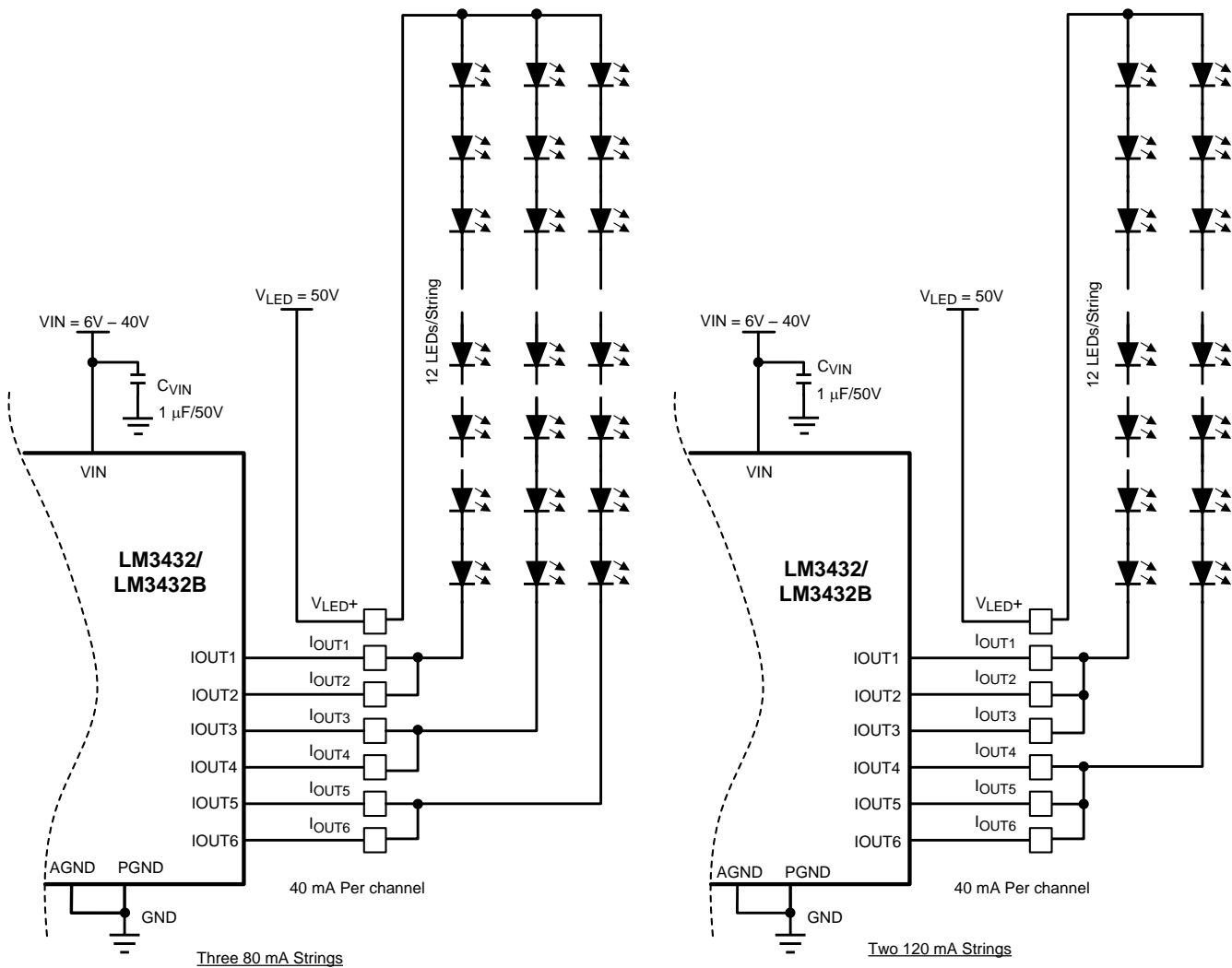

Figure 18. Achieving Higher LED String Current by Grouping IOUT Ports

Dynamic Headroom Control, DHC with LM3430

When the LM3432/LM3432B are powered with Texas Instruments Semiconductor's Boost Controller for LED Backlighting, LM3430, the Dynamic Headroom Control (DHC) feature helps to provide the optimal system efficiency. By connecting VDHC through a gain setting resistor to the DHC pin of the LM3430 that is supplying the LED power rail, the LM3432/LM3432B's DHC function will regulate the minimum of the ON voltage of the six channels to 0.625V typical ($I_{OUT} = 20$ mA). This is the minimum voltage headroom required at outputs to keep the current regulator in its linear operating range. In order not to interfere with the feedback loop response of the upstream DC-DC converter, the DHC response time constant must be set to a large enough value by adding a capacitor from CDHC pin to ground.

Figure 19 is an application schematic of a LED panel driver using both the LM3430 and the LM3432/LM3432B with the Dynamic Headroom Control function enabled. The LM3430 boosts a voltage from VIN to 50V nominal to supply the LED strings. With the DHC function disabled, the LM3430 will keep the LED string supply regulated at 50V. When the DHC is enabled, this voltage will dynamically be regulated down to a voltage that can just keep all LED string currents in regulation. That is about 40V in the application shown in Figure 19. The reduction in this rail voltage can significantly improve the overall system efficiency.

REVISION HISTORY

Changes from Revision C (May 2013) to Revision D	Page
• Changed layout of National Data Sheet to TI format	17

PACKAGING INFORMATION

Orderable Device	Status (1)	Package Type	Package Drawing	Pins	Package Qty	Eco Plan (2)	Lead/Ball Finish (6)	MSL Peak Temp (3)	Op Temp (°C)	Device Marking (4/5)	Samples
LM3432BSQ/NOPB	ACTIVE	WQFN	NHZ	24		TBD	Call TI	Call TI	-40 to 125	3432BSQ	Samples
LM3432BSQE/NOPB	ACTIVE	WQFN	NHZ	24	250	Green (RoHS & no Sb/Br)	CU SN	Level-1-260C-UNLIM	-40 to 125	3432BSQ	Samples
LM3432BSQX/NOPB	ACTIVE	WQFN	NHZ	24		TBD	Call TI	Call TI	-40 to 125	3432BSQ	Samples
LM3432MH/NOPB	ACTIVE	HTSSOP	PWP	28	48	Green (RoHS & no Sb/Br)	CU SN	Level-3-260C-168 HR	-40 to 125	LM3432 MH	Samples
LM3432MHX/NOPB	ACTIVE	HTSSOP	PWP	28	2500	Green (RoHS & no Sb/Br)	CU SN	Level-3-260C-168 HR	-40 to 125	LM3432 MH	Samples
LM3432SQ/NOPB	ACTIVE	WQFN	NHZ	24	1000	Green (RoHS & no Sb/Br)	CU SN	Level-1-260C-UNLIM	-40 to 125	L3432SQ	Samples
LM3432SQE/NOPB	ACTIVE	WQFN	NHZ	24	250	Green (RoHS & no Sb/Br)	CU SN	Level-1-260C-UNLIM	-40 to 125	L3432SQ	Samples
LM3432SQX/NOPB	ACTIVE	WQFN	NHZ	24	4500	Green (RoHS & no Sb/Br)	CU SN	Level-1-260C-UNLIM	-40 to 125	L3432SQ	Samples

(1) The marketing status values are defined as follows:

ACTIVE: Product device recommended for new designs.

LIFEBUY: TI has announced that the device will be discontinued, and a lifetime-buy period is in effect.

NRND: Not recommended for new designs. Device is in production to support existing customers, but TI does not recommend using this part in a new design.

PREVIEW: Device has been announced but is not in production. Samples may or may not be available.

OBSOLETE: TI has discontinued the production of the device.

(2) Eco Plan - The planned eco-friendly classification: Pb-Free (RoHS), Pb-Free (RoHS Exempt), or Green (RoHS & no Sb/Br) - please check <http://www.ti.com/productcontent> for the latest availability information and additional product content details.

TBD: The Pb-Free/Green conversion plan has not been defined.

Pb-Free (RoHS): TI's terms "Lead-Free" or "Pb-Free" mean semiconductor products that are compatible with the current RoHS requirements for all 6 substances, including the requirement that lead not exceed 0.1% by weight in homogeneous materials. Where designed to be soldered at high temperatures, TI Pb-Free products are suitable for use in specified lead-free processes.

Pb-Free (RoHS Exempt): This component has a RoHS exemption for either 1) lead-based flip-chip solder bumps used between the die and package, or 2) lead-based die adhesive used between the die and leadframe. The component is otherwise considered Pb-Free (RoHS compatible) as defined above.

Green (RoHS & no Sb/Br): TI defines "Green" to mean Pb-Free (RoHS compatible), and free of Bromine (Br) and Antimony (Sb) based flame retardants (Br or Sb do not exceed 0.1% by weight in homogeneous material)

(3) MSL, Peak Temp. - The Moisture Sensitivity Level rating according to the JEDEC industry standard classifications, and peak solder temperature.

(4) There may be additional marking, which relates to the logo, the lot trace code information, or the environmental category on the device.

⁽⁵⁾ Multiple Device Markings will be inside parentheses. Only one Device Marking contained in parentheses and separated by a "~" will appear on a device. If a line is indented then it is a continuation of the previous line and the two combined represent the entire Device Marking for that device.

⁽⁶⁾ Lead/Ball Finish - Orderable Devices may have multiple material finish options. Finish options are separated by a vertical ruled line. Lead/Ball Finish values may wrap to two lines if the finish value exceeds the maximum column width.

Important Information and Disclaimer:The information provided on this page represents TI's knowledge and belief as of the date that it is provided. TI bases its knowledge and belief on information provided by third parties, and makes no representation or warranty as to the accuracy of such information. Efforts are underway to better integrate information from third parties. TI has taken and continues to take reasonable steps to provide representative and accurate information but may not have conducted destructive testing or chemical analysis on incoming materials and chemicals. TI and TI suppliers consider certain information to be proprietary, and thus CAS numbers and other limited information may not be available for release.

In no event shall TI's liability arising out of such information exceed the total purchase price of the TI part(s) at issue in this document sold by TI to Customer on an annual basis.

TAPE AND REEL INFORMATION

QUADRANT ASSIGNMENTS FOR PIN 1 ORIENTATION IN TAPE

*All dimensions are nominal

Device	Package Type	Package Drawing	Pins	SPQ	Reel Diameter (mm)	Reel Width W1 (mm)	A0 (mm)	B0 (mm)	K0 (mm)	P1 (mm)	W (mm)	Pin1 Quadrant
LM3432BSQE/NOPB	WQFN	NHZ	24	250	178.0	12.4	4.3	5.3	1.3	8.0	12.0	Q1
LM3432MHX/NOPB	HTSSOP	PWP	28	2500	330.0	16.4	6.8	10.2	1.6	8.0	16.0	Q1
LM3432SQ/NOPB	WQFN	NHZ	24	1000	178.0	12.4	4.3	5.3	1.3	8.0	12.0	Q1
LM3432SQE/NOPB	WQFN	NHZ	24	250	178.0	12.4	4.3	5.3	1.3	8.0	12.0	Q1
LM3432SQX/NOPB	WQFN	NHZ	24	4500	330.0	12.4	4.3	5.3	1.3	8.0	12.0	Q1

TAPE AND REEL BOX DIMENSIONS



*All dimensions are nominal

Device	Package Type	Package Drawing	Pins	SPQ	Length (mm)	Width (mm)	Height (mm)
LM3432BSQE/NOPB	WQFN	NHZ	24	250	210.0	185.0	35.0
LM3432MHX/NOPB	HTSSOP	PWP	28	2500	367.0	367.0	38.0
LM3432SQ/NOPB	WQFN	NHZ	24	1000	210.0	185.0	35.0
LM3432SQE/NOPB	WQFN	NHZ	24	250	210.0	185.0	35.0
LM3432SQX/NOPB	WQFN	NHZ	24	4500	367.0	367.0	35.0

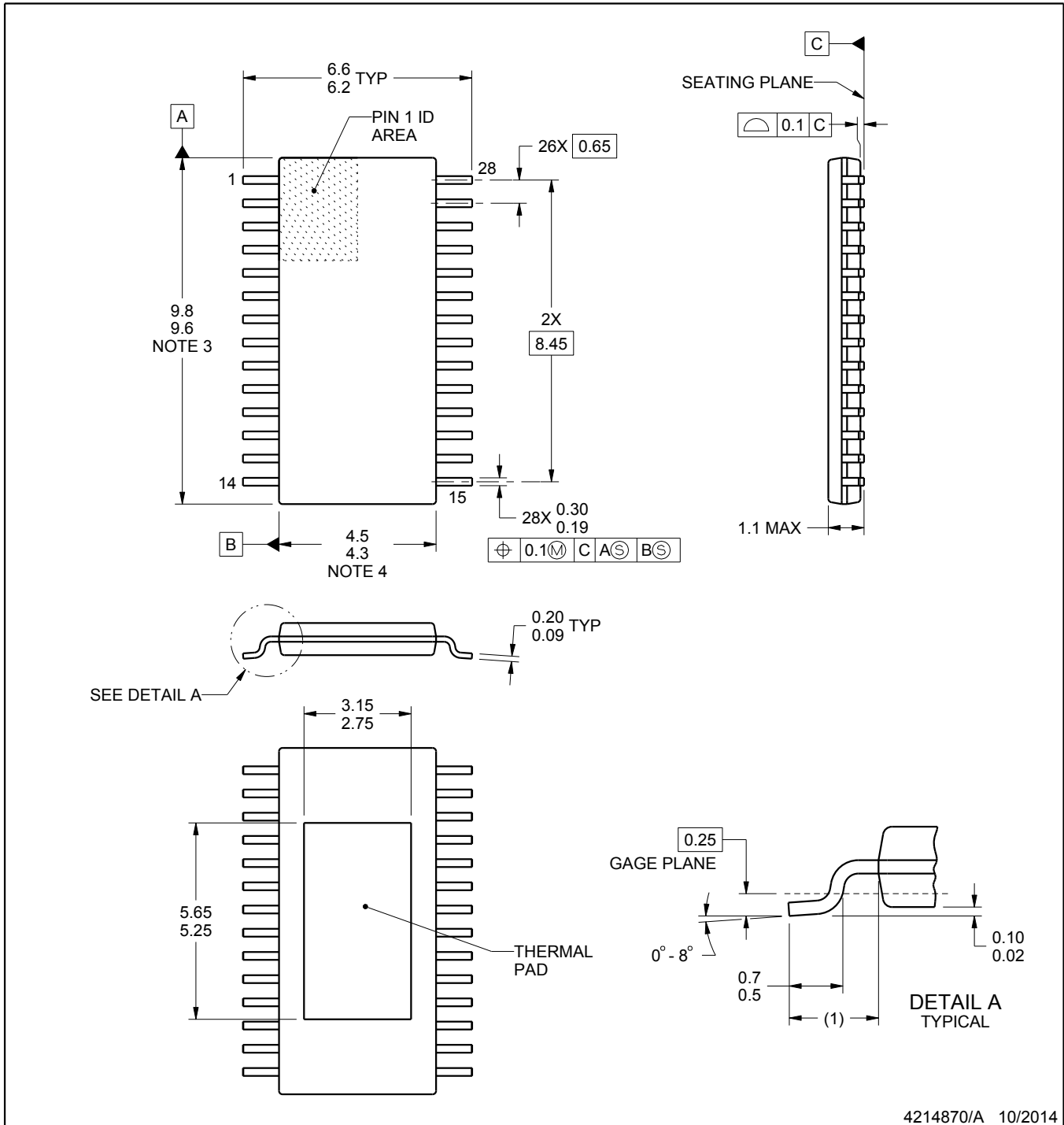
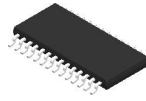

4214870/A 10/2014

NOTES:

PowerPAD is a trademark of Texas Instruments.

1. All linear dimensions are in millimeters. Any dimensions in parenthesis are for reference only. Dimensioning and tolerancing per ASME Y14.5M.
2. This drawing is subject to change without notice.
3. This dimension does not include mold flash, protrusions, or gate burrs. Mold flash, protrusions, or gate burrs shall not exceed 0.15 mm, per side.
4. This dimension does not include interlead flash. Interlead flash shall not exceed 0.25 mm, per side.
5. Reference JEDEC registration MO-153, variation AET.

EXAMPLE BOARD LAYOUT

PWP0028A

PowerPAD™ - 1.1 mm max height

PLASTIC SMALL OUTLINE

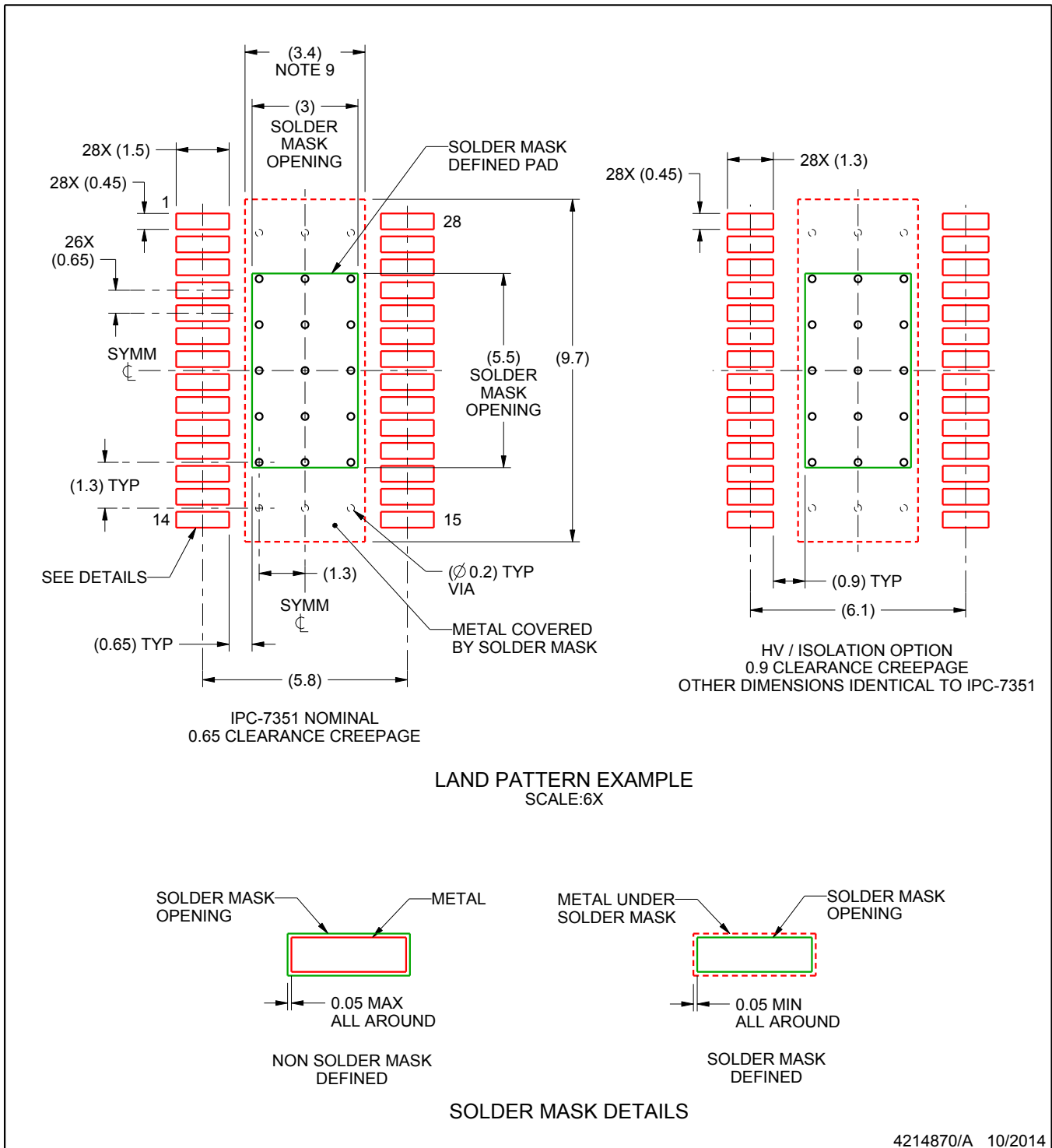

NOTES: (continued)

6. Publication IPC-7351 may have alternate designs.
7. Solder mask tolerances between and around signal pads can vary based on board fabrication site.
8. This package is designed to be soldered to a thermal pad on the board. For more information, see Texas Instruments literature numbers SLMA002 (www.ti.com/lit/slma002) and SLMA004 (www.ti.com/lit/slma004).
9. Size of metal pad may vary due to creepage requirement.

EXAMPLE STENCIL DESIGN

PWP0028A

PowerPAD™ - 1.1 mm max height

PLASTIC SMALL OUTLINE

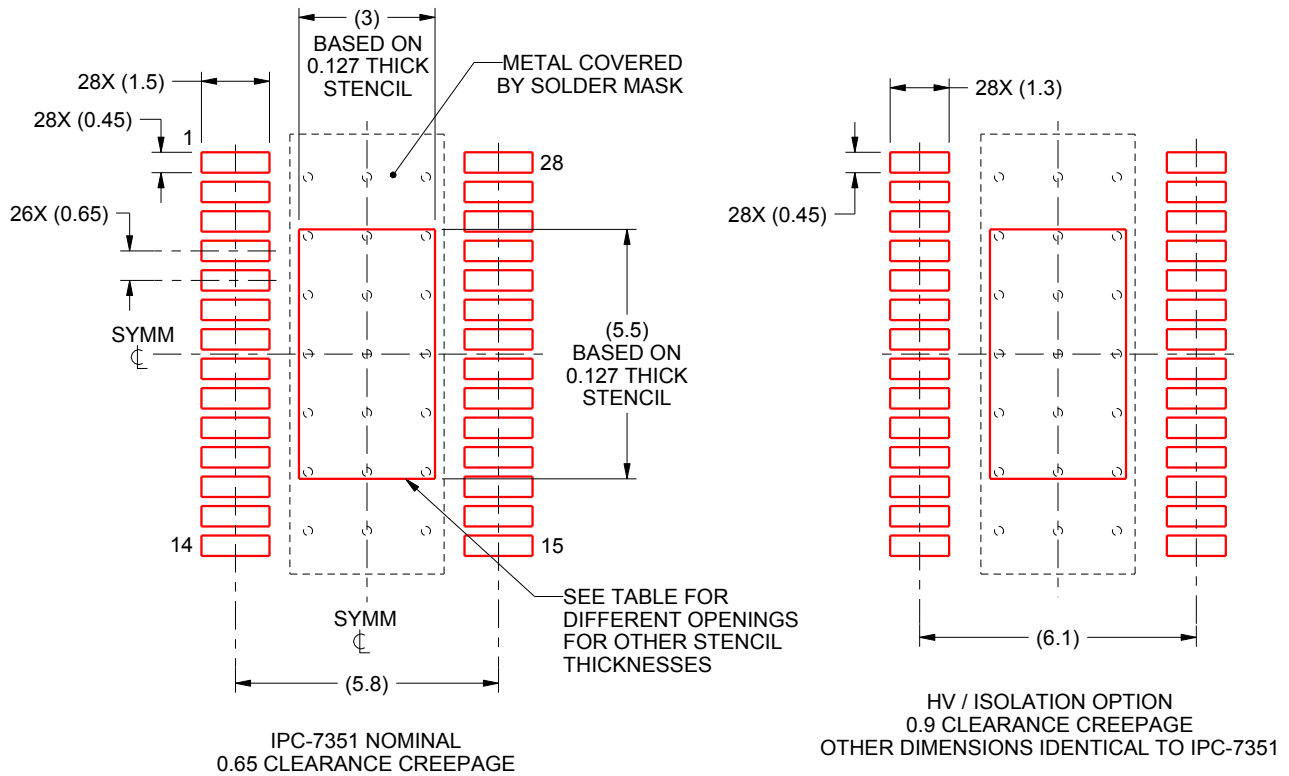

SOLDER PASTE EXAMPLE
EXPOSED PAD
100% PRINTED SOLDER COVERAGE AREA
SCALE:6X

STENCIL THICKNESS	SOLDER STENCIL OPENING
0.1	3.55 X 6.37
0.127	3.0 X 5.5 (SHOWN)
0.152	2.88 X 5.16
0.178	2.66 X 4.77

4214870/A 10/2014

NOTES: (continued)

10. Laser cutting apertures with trapezoidal walls and rounded corners may offer better paste release. IPC-7525 may have alternate design recommendations.
11. Board assembly site may have different recommendations for stencil design.

IMPORTANT NOTICE

Texas Instruments Incorporated and its subsidiaries (TI) reserve the right to make corrections, enhancements, improvements and other changes to its semiconductor products and services per JESD46, latest issue, and to discontinue any product or service per JESD48, latest issue. Buyers should obtain the latest relevant information before placing orders and should verify that such information is current and complete. All semiconductor products (also referred to herein as "components") are sold subject to TI's terms and conditions of sale supplied at the time of order acknowledgment.

TI warrants performance of its components to the specifications applicable at the time of sale, in accordance with the warranty in TI's terms and conditions of sale of semiconductor products. Testing and other quality control techniques are used to the extent TI deems necessary to support this warranty. Except where mandated by applicable law, testing of all parameters of each component is not necessarily performed.

TI assumes no liability for applications assistance or the design of Buyers' products. Buyers are responsible for their products and applications using TI components. To minimize the risks associated with Buyers' products and applications, Buyers should provide adequate design and operating safeguards.

TI does not warrant or represent that any license, either express or implied, is granted under any patent right, copyright, mask work right, or other intellectual property right relating to any combination, machine, or process in which TI components or services are used. Information published by TI regarding third-party products or services does not constitute a license to use such products or services or a warranty or endorsement thereof. Use of such information may require a license from a third party under the patents or other intellectual property of the third party, or a license from TI under the patents or other intellectual property of TI.

Reproduction of significant portions of TI information in TI data books or data sheets is permissible only if reproduction is without alteration and is accompanied by all associated warranties, conditions, limitations, and notices. TI is not responsible or liable for such altered documentation. Information of third parties may be subject to additional restrictions.

Resale of TI components or services with statements different from or beyond the parameters stated by TI for that component or service voids all express and any implied warranties for the associated TI component or service and is an unfair and deceptive business practice. TI is not responsible or liable for any such statements.

Buyer acknowledges and agrees that it is solely responsible for compliance with all legal, regulatory and safety-related requirements concerning its products, and any use of TI components in its applications, notwithstanding any applications-related information or support that may be provided by TI. Buyer represents and agrees that it has all the necessary expertise to create and implement safeguards which anticipate dangerous consequences of failures, monitor failures and their consequences, lessen the likelihood of failures that might cause harm and take appropriate remedial actions. Buyer will fully indemnify TI and its representatives against any damages arising out of the use of any TI components in safety-critical applications.

In some cases, TI components may be promoted specifically to facilitate safety-related applications. With such components, TI's goal is to help enable customers to design and create their own end-product solutions that meet applicable functional safety standards and requirements. Nonetheless, such components are subject to these terms.

No TI components are authorized for use in FDA Class III (or similar life-critical medical equipment) unless authorized officers of the parties have executed a special agreement specifically governing such use.

Only those TI components which TI has specifically designated as military grade or "enhanced plastic" are designed and intended for use in military/aerospace applications or environments. Buyer acknowledges and agrees that any military or aerospace use of TI components which have **not** been so designated is solely at the Buyer's risk, and that Buyer is solely responsible for compliance with all legal and regulatory requirements in connection with such use.

TI has specifically designated certain components as meeting ISO/TS16949 requirements, mainly for automotive use. In any case of use of non-designated products, TI will not be responsible for any failure to meet ISO/TS16949.

Products

Audio	www.ti.com/audio
Amplifiers	amplifier.ti.com
Data Converters	dataconverter.ti.com
DLP® Products	www.dlp.com
DSP	dsp.ti.com
Clocks and Timers	www.ti.com/clocks
Interface	interface.ti.com
Logic	logic.ti.com
Power Mgmt	power.ti.com
Microcontrollers	microcontroller.ti.com
RFID	www.ti-rfid.com
OMAP Applications Processors	www.ti.com/omap
Wireless Connectivity	www.ti.com/wirelessconnectivity

Applications

Automotive and Transportation	www.ti.com/automotive
Communications and Telecom	www.ti.com/communications
Computers and Peripherals	www.ti.com/computers
Consumer Electronics	www.ti.com/consumer-apps
Energy and Lighting	www.ti.com/energy
Industrial	www.ti.com/industrial
Medical	www.ti.com/medical
Security	www.ti.com/security
Space, Avionics and Defense	www.ti.com/space-avionics-defense
Video and Imaging	www.ti.com/video

TI E2E Community

e2e.ti.com

Looking for pricing, stock, or lifecycle information?

Click below to explore more details on WIN SOURCE:

 [View LM3432MHX/NOPB on WIN SOURCE](#)

 [Texas Instruments](#) Information

Optimize Your Supply Chain with WIN SOURCE Solutions

-  Global Sourcing Solution
-  Obsolete Management
-  Cost Control Management
-  Shortage Management
-  Alternative Solution
-  Excess Inventory Management