

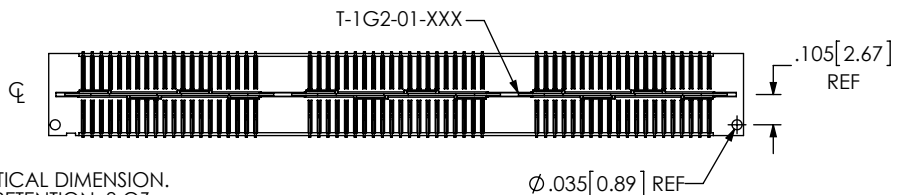
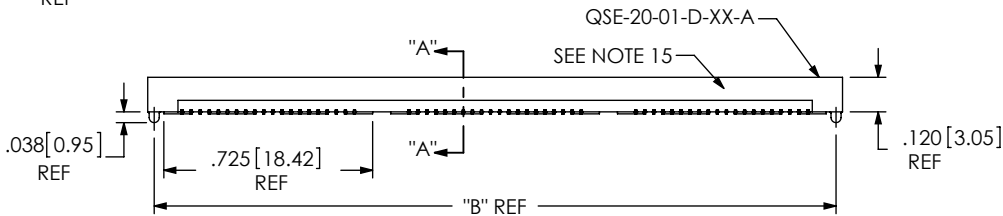
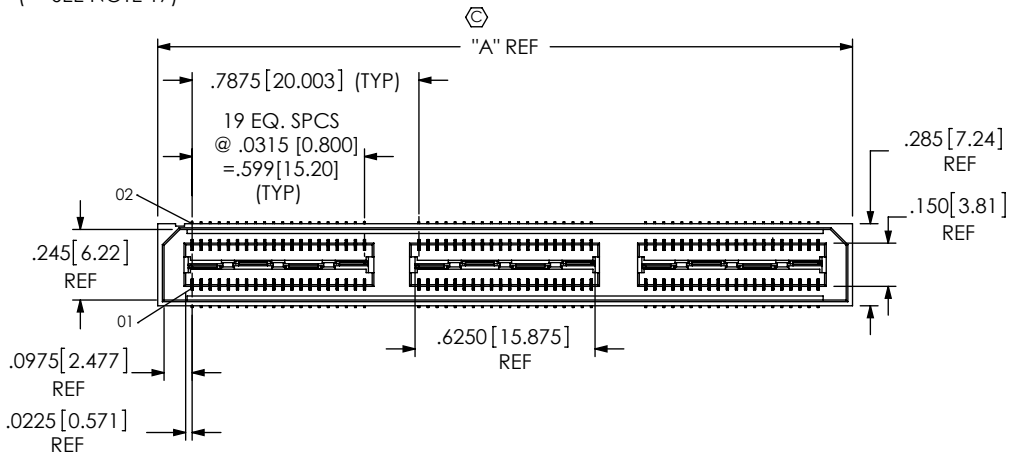


TABLE 2		
No OF POS	"A"	"B"
-020	.838 [21.27]	.793 [20.13]
-040	1.625 [41.28]	1.580 [40.13]
-060	2.413 [61.28]	2.368 [60.13]
*-080	3.200 [81.28]	3.155 [80.14]
*-100	3.988 [101.28]	3.943 [100.14]

(\* = SEE NOTE 17)

TABLE 1	
No OF POS	COPLANARITY INCLUDING GP
-020 THRU -040	.004[0.10]
-060, *-080, *-100	.006[0.15]

(\* = SEE NOTE 17)



NOTES:

1.  $\odot$  REPRESENTS A CRITICAL DIMENSION.
2. MINIMUM CONTACT RETENTION: 8 OZ
3. MINIMUM GROUND PLANE RETENTION: 8 OZ
4. PARTS ARE MOLDED TO POSITION.
5. DELETED.
6. MAXIMUM VARIANCE: .002[0.51].
7. DIMENSION APPLIES TO CONTACTS & GROUND PLANE.
8. -L PLATING CAN BE SUBSTITUTED FOR -F PLATING, -G PLATED GROUND PLANE CAN BE SUBSTITUTED FOR -F PLATED GROUND PLANE.
9. GROUND PLANE PRESS HEIGHT MUST BE .003 [0.08] LESS THAN THE MAX HEIGHT OR .001 [0.03] GREATER THAN THE MINIMUM HEIGHT OF THE SOCKETS.
10. MINIMUM SUB-SC-05-01-XX RETENTION: 1 LB IN BODY.
11. MAY SUB C-126-01-XXX FOR C-126-21-XXX.
12. NOTE DELETED.
13. FOR -080, -100 POSITIONS USE C-269-11-XXX. DO NOT SUB C-126.
14. DUE TO THE HIGH AMOUNT OF INSERTION FORCE NEEDED, THE -LC OPTION IS NOT COMPATIBLE WITH AUTO PLACEMENT. SAMTEC RECOMMENDS MANUAL PLACEMENT FOR ALL ASSEMBLIES WITH THE -LC OPTION.
15. SIDE WALLS ARE RIBBED AS NECESSARY TO CONTROL BOW.
16. CHECK ONCE PER BANK ALTERNATING SIDES FOR MULTIPLE BANK PARTS.
17. AVAILABLE FOR EXISTING CUSTOMERS ONLY.
18. NOTE DELETED.

QSE-XXX-01-XXX-D-XXX

No OF POSITIONS  
-020, -040, -060  
\*-080, \*-100 (PER ROW)  
(\* = SEE NOTE 17)

LEAD STYLE  
-01: .1280[3.251]

PLATING SPECIFICATION

- (SEE NOTES 8, 11 & 13)
- F: 3 $\mu$ " SELECTIVE GOLD IN CONTACT AREA, MATTE TIN ON TAIL (USE C-126-21-F, T-1G2-01-F) (SEE NOTE 8)
- L: 10 $\mu$ " SELECTIVE GOLD IN CONTACT AREA, MATTE TIN ON TAIL (USE C-126-21-L, T-1G2-01-L)
- H: 30 $\mu$ " GOLD IN CONTACT AREA, 3 $\mu$ " GOLD ON TAIL (USE C-126-21-H, T-1G2-01-G)
- C: 50 $\mu$ " ELECTRO POLISHED SELECTIVE GOLD IN CONTACT AREA, MATTE TIN ON TAIL (USE C-126-21-C, T-1G2-01-L)
- STL: 30 $\mu$ " SELECTIVE GOLD IN CONTACT AREA, TIN LEAD (90/10  $\pm$ 5%) ON TAIL (USE C-126-21-STL, T-1G2-01-STL)
- FTL: 3 $\mu$ " SELECTIVE GOLD IN CONTACT AREA, TIN LEAD (90/10  $\pm$ 5%) ON TAIL (USE C-126-21-FTL, T-1G2-01-FTL)
- LTL: 10 $\mu$ " SELECTIVE GOLD IN CONTACT AREA, TIN LEAD (90/10  $\pm$ 5%) ON TAIL (USE C-126-21-LTL, T-1G2-01-LTL)
- S: 30 $\mu$ " SELECTIVE GOLD IN CONTACT AREA, MATTE TIN ON TAIL (USE C-126-21-S, T-1G2-01-L)

OPTION

- A: ALIGNMENT PINS (USE QSE-20-XX-D-XX-A) (NOT AVAILABLE WITH -LC OPTION)
- LC: LOCKING CLIPS (SEE NOTE 14) (USE LC-08-1M-01, SEE FIG 2, SHT 2) (NOT AVAILABLE WITH -A OPTION)
- GP: GUIDE POSTS (SEE FIG 4, SHT 3) (USE QSE-20-01-D-XX-X-GP) (T & R PACKAGING: 40 POS MAX)
- K: POLYIMIDE FILM (USE K-DOT-.325-.450-.005) (SEE FIG 3, SHT 2)
- TR: TAPE & REEL (60 POS MAX) (SEE FIG 8, SHT 5)
- (40 POS MAX -GP OPTION)
- FL: FRICTION LOCKS (SEE FIG 5, SHT 3)
- (NOT AVAILABLE WITH -GP)
- RT1: RETENTION OPTION (MUST USE -A OPTION) (USE QSE-20-01-D-XX-A-RT1 & SUB-SC-05-01-FF) (SEE FIG 6, SHT 4)
- (NOT AVAILABLE WITH -LC, -GP, OR -FL)
- (NOT AVAILABLE WITH -100 POS)
- L: LATCHING OPTION (40 POS MAX) (SEE FIG 7, SHT 4)
- (MUST USE -A OPTION)
- (NOT AVAILABLE WITH -LC, -GP, -FL, OR -RT1)

ROW SPECIFICATION

- D: DOUBLE (USE QSE-20-XX-D-XX)
- No OF BANKS

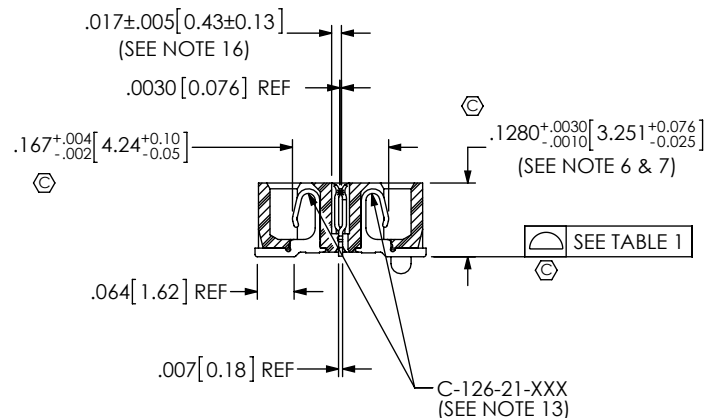


FIG 1

-A: ALIGNMENT PIN OPTION (QSE-060-01-XXX-D-A SHOWN)

SECTION "A"-A

UNLESS OTHERWISE SPECIFIED, DIMENSIONS ARE IN INCHES.

TOLERANCES ARE:  
DECIMALS ANGLES  
.XX:  $\pm$  .01 [3]  
.XXX:  $\pm$  .005 [13]  
.XXXX:  $\pm$  .0020 [051]

PROPRIETARY NOTE

THIS DOCUMENT CONTAINS CONFIDENTIAL AND PROPRIETARY INFORMATION AND ALL DESIGN, MANUFACTURING, REPRODUCTION, USE, PATENT RIGHTS AND SALES RIGHTS ARE EXPRESSLY RESERVED BY SAMTEC, INC. THIS DOCUMENT SHALL NOT BE DISCLOSED, IN WHOLE OR PART, TO ANY UNAUTHORIZED PERSON OR ENTITY NOR REPRODUCED, TRANSFERRED OR INCORPORATED IN ANY OTHER PROJECT IN ANY MANNER WITHOUT THE EXPRESS WRITTEN CONSENT OF SAMTEC, INC.

MATERIAL: DO NOT SCALE DRAWING SHEET SCALE: 1.5:1  
INSULATOR: LCP, UL94V-0; COLOR: BLACK  
CONTACT: PHOS BRONZE  
GROUND PLANE: PHOS BRONZE

DESCRIPTION: .8mm DOUBLE ROW HS SOCKET ASSEMBLY

DWG. NO. QSE-XXX-01-XXX-D-XXX

BY: ERIC M 05/20/1999 SHEET 1 OF 5



520 PARK EAST BLVD, NEW ALBANY, IN 47150  
PHONE: 812-944-6733 FAX: 812-948-5047  
e-Mail: info@SAMTEC.com code 55322

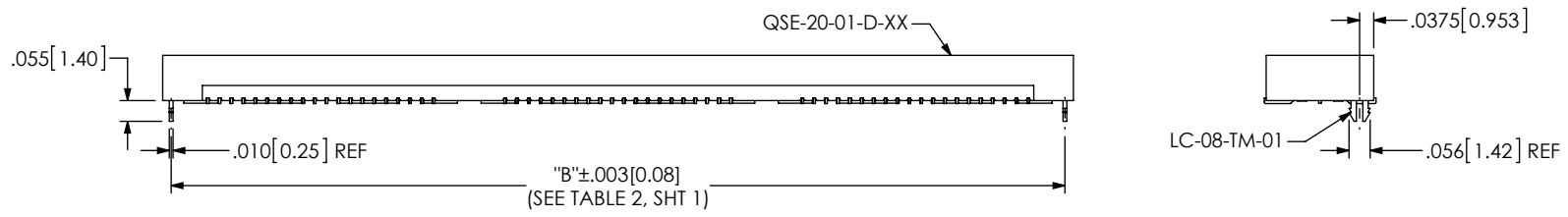


FIG 2  
 -LC: LOCKING CLIP OPTION  
 (QSE-060-01-XXX-D-LC SHOWN)  
 (DIFFERENT AS SHOWN, OTHERWISE SAME AS FIG 1)

**TABLE 3**

No OF POS	"R"				"S"			
	-LC, -A, -FL	-GP	-RT1	-L	-LC, -A, -FL	-GP	-RT1	-L
-020	.839 [21.31]	1.216 [30.89]	1.438 [36.51]	1.048 [26.61]	.257 [6.53]	.446 [11.32]	.556 [14.13]	.361 [9.18]
-040	1.627 [41.31]	2.004 [50.89]	2.225 [56.52]	1.835 [46.61]	.651 [16.53]	.839 [21.32]	.950 [24.13]	.755 [19.18]
-060	2.417 [61.38]	2.791 [70.89]	3.013 [76.52]	N/A	1.046 [26.56]	1.233 [31.32]	1.344 [34.13]	N/A
*-080	3.204 [81.38]	3.579 [90.89]	3.800 [96.52]	N/A	1.440 [36.56]	1.627 [41.32]	1.738 [44.13]	N/A
*-100	3.991 [101.37]	4.366 [110.90]	N/A	N/A	1.833 [46.56]	2.021 [51.32]	N/A	N/A

(\* = SEE NOTE 17)

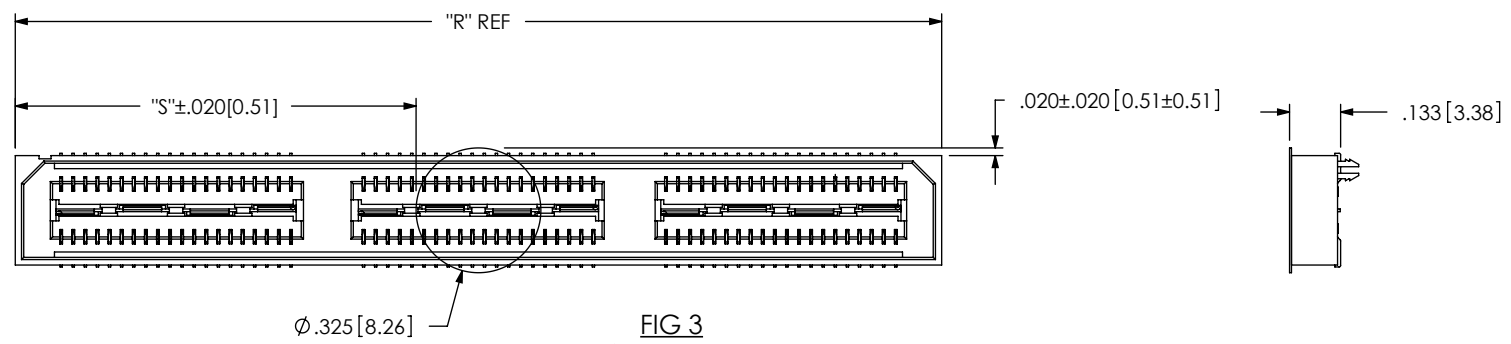



FIG 3  
 -K: POLYIMIDE FILM PAD  
 (K-DOT-.325-.450-.005)

F:\DWG\MISC\MKTG\QSE-XXX-01-XXX-D-XXX-MKT.SLDDRW

<p>DO NOT SCALE DRAWING</p> <p>SHEET SCALE: 2:1</p>	<p><b>PROPRIETARY NOTE</b></p> <p>THIS DOCUMENT CONTAINS CONFIDENTIAL AND PROPRIETARY INFORMATION AND ALL DESIGN, MANUFACTURING, REPRODUCTION, USE, PATENT RIGHTS AND SALES RIGHTS ARE EXPRESSLY RESERVED BY SAMTEC, INC. THIS DOCUMENT SHALL NOT BE DISCLOSED, IN WHOLE OR PART, TO ANY UNAUTHORIZED PERSON OR ENTITY NOR REPRODUCED, TRANSFERRED OR INCORPORATED IN ANY OTHER PROJECT IN ANY MANNER WITHOUT THE EXPRESS WRITTEN CONSENT OF SAMTEC, INC.</p>	
	<p>520 PARK EAST BLVD, NEW ALBANY, IN 47150                  PHONE: 812-944-6733 FAX: 812-948-5047                  e-Mail info@SAMTEC.com code 55322</p>	
	<p>DESCRIPTION:                  .8mm DOUBLE ROW HS SOCKET ASSEMBLY</p> <p>DWG. NO.  <b>QSE-XXX-01-XXX-D-XXX</b></p>	
<p>BY: ERIC M 05/20/1999</p>		<p>SHEET 2 OF 5</p>

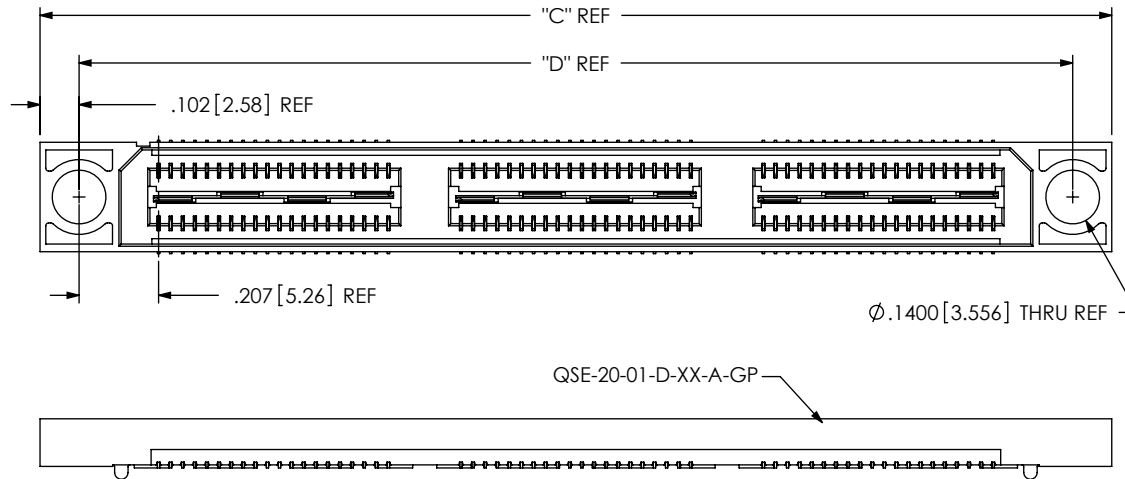
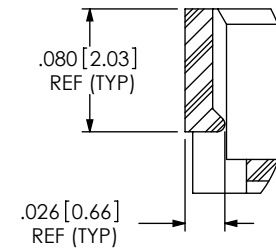
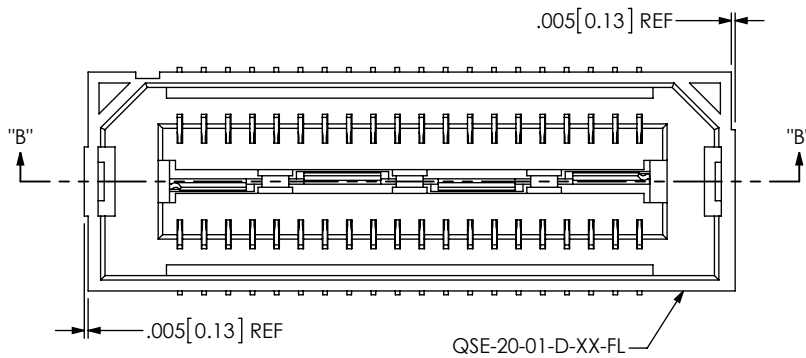


TABLE 4		
POS	"C"	"D"
-020	1.216 [30.89]	1.013 [25.72]
-040	2.004 [50.89]	1.800 [45.72]
-060	2.791 [70.89]	2.588 [65.72]
*-080	3.579 [90.89]	3.375 [85.73]
*-100	4.366 [110.90]	4.163 [105.73]

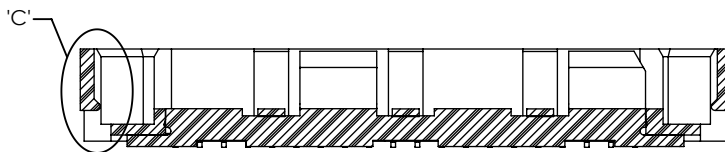
(\* = SEE NOTE 17)

**FIG 4**  
 -GP: GUIDE POST OPTION  
 (QSE-060-01-XXX-D-A-GP SHOWN)  
 (DIFFERENT AS SHOWN, OTHERWISE SAME AS FIG 1)  
 (40 POS MAX WITH T & R PACKAGING)



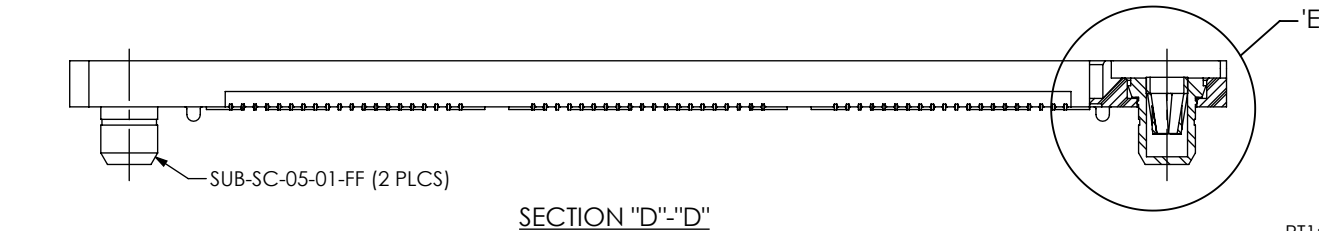
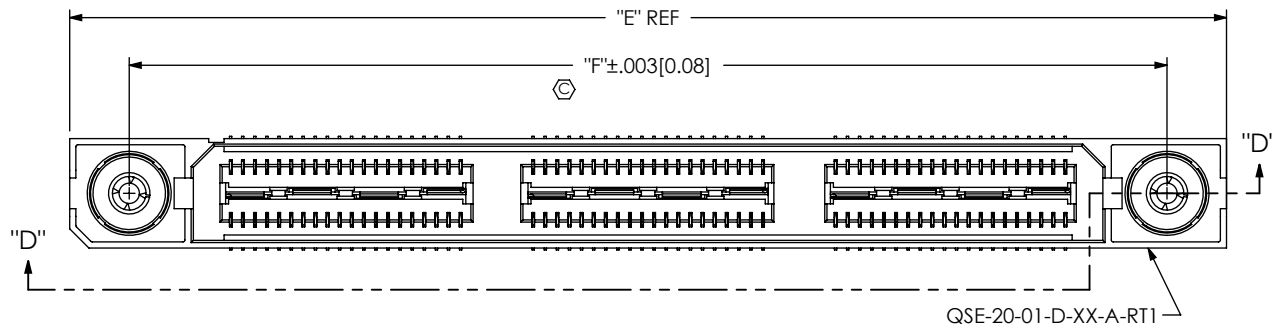
**DETAIL 'C'**  
 SCALE 8 : 1

**FIG 5**  
 -FL: FRICTION LOCKS  
 (QSE-020-01-XXX-D-FL SHOWN)  
 (DIFFERENT AS SHOWN, OTHERWISE SAME AS FIG 1)  
 (NOT AVAILABLE WITH -GP OPTION)



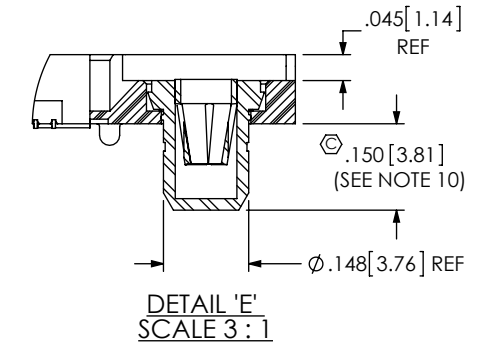
**SECTION "B"-"B"**  
 SCALE 4 : 1

<p>DO NOT SCALE DRAWING</p> <p>SHEET SCALE: 2:1</p>	<p><b>PROPRIETARY NOTE</b></p> <p>THIS DOCUMENT CONTAINS CONFIDENTIAL AND PROPRIETARY INFORMATION AND ALL DESIGN, MANUFACTURING, REPRODUCTION, USE, PATENT RIGHTS AND SALES RIGHTS ARE EXPRESSLY RESERVED BY SAMTEC, INC. THIS DOCUMENT SHALL NOT BE DISCLOSED, IN WHOLE OR PART, TO ANY UNAUTHORIZED PERSON OR ENTITY NOR REPRODUCED, TRANSFERRED OR INCORPORATED IN ANY OTHER PROJECT IN ANY MANNER WITHOUT THE EXPRESS WRITTEN CONSENT OF SAMTEC, INC.</p>	<p><b>samtec</b></p> <p>520 PARK EAST BLVD, NEW ALBANY, IN 47150                  PHONE: 812-944-6733 FAX: 812-948-5047                  e-Mail info@SAMTEC.com code 55322</p>
	<p>DESCRIPTION:                  .8mm DOUBLE ROW HS SOCKET ASSEMBLY</p>	
	<p>DWG. NO.                  QSE-XXX-01-XXX-D-XXX</p>	
<p>BY: ERIC M 05/20/1999</p>		<p>SHEET 3 OF 5</p>

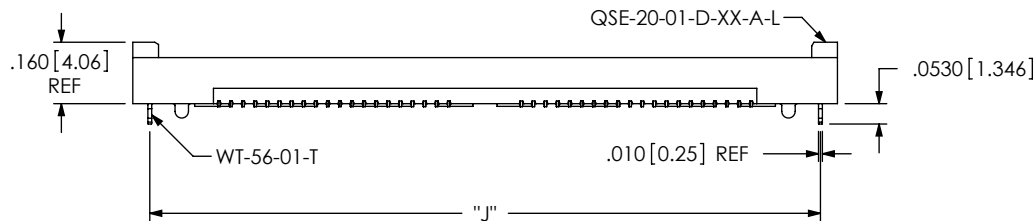
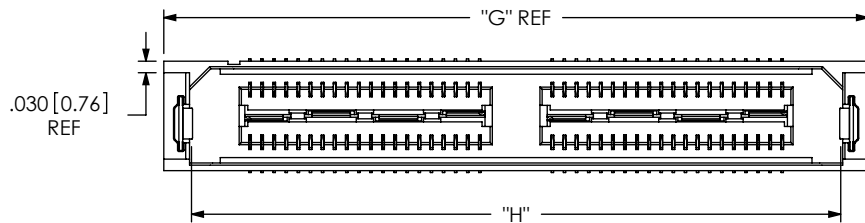


POS	"E"	"F"
-020	1.438 [36.51]	1.129 [28.66]
-040	2.225 [56.52]	1.916 [48.67]
-060	3.013 [76.52]	2.704 [68.67]
*-080	3.800 [96.52]	3.491 [88.67]
*-100	N/A	N/A

(\* = SEE NOTE 17)

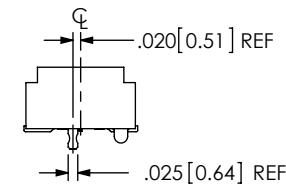


**FIG 6**  
 -RT1: RETENTION OPTION  
 (QSE-060-01-XXX-D-A-RT1 SHOWN)  
 (DIFFERENT AS SHOWN, OTHERWISE SAME AS FIG 1)  
 (MUST USE -A OPTION)  
 (NOT AVAILABLE WITH -LC, -GP, OR -FL OPTIONS)  
 (NOT AVAILABLE WITH -100 POS)



POS	"G"	"H"	"J"
-020	1.048 [26.61]	.897 [22.78]	.959 [24.36]
-040	1.835 [46.61]	1.684 [42.78]	1.747 [44.36]
-060	N/A	N/A	N/A
*-080	N/A	N/A	N/A
*-100	N/A	N/A	N/A

(\* = SEE NOTE 17)



**FIG 7**  
 -L: LATCHING OPTION  
 (QSE-040-01-XXX-D-A-L SHOWN)  
 (DIFFERENT AS SHOWN, OTHERWISE SAME AS FIG 1)  
 (MUST USE -A OPTION) (40 POS MAX)  
 (NOT AVAILABLE WITH -LC, -GP, -FL, OR -RT1 OPTIONS)

**PROPRIETARY NOTE**  
 THIS DOCUMENT CONTAINS CONFIDENTIAL AND PROPRIETARY INFORMATION AND ALL DESIGN, MANUFACTURING, REPRODUCTION, USE, PATENT RIGHTS AND SALES RIGHTS ARE EXPRESSLY RESERVED BY SAMTEC, INC. THIS DOCUMENT SHALL NOT BE DISCLOSED, IN WHOLE OR PART, TO ANY UNAUTHORIZED PERSON OR ENTITY NOR REPRODUCED, TRANSFERRED OR INCORPORATED IN ANY OTHER PROJECT IN ANY MANNER WITHOUT THE EXPRESS WRITTEN CONSENT OF SAMTEC, INC.



520 PARK EAST BLVD, NEW ALBANY, IN 47150  
 PHONE: 812-944-6733 FAX: 812-948-5047  
 e-Mail info@SAMTEC.com code 55322

DO NOT SCALE DRAWING

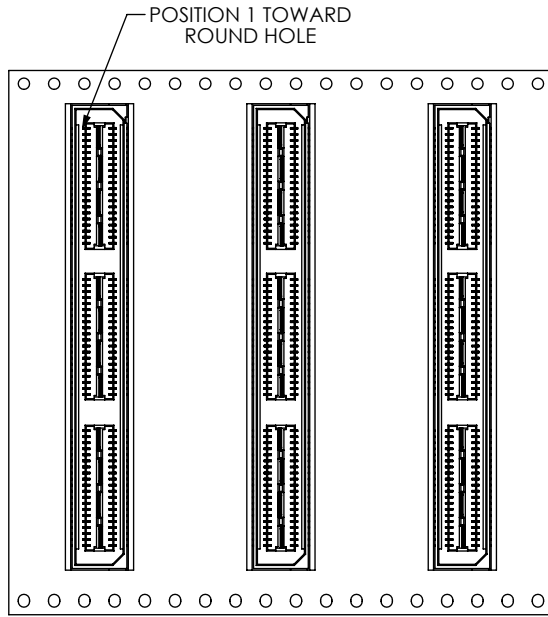
SHEET SCALE: 2:1

DESCRIPTION:  
 .8mm DOUBLE ROW HS SOCKET ASSEMBLY

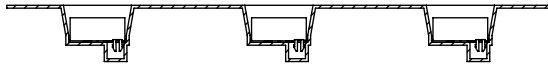
DWG. NO.  
**QSE-XXX-01-XXX-D-XXX**

BY: ERIC M 05/20/1999 SHEET 4 OF 5

FIG 8  
 -TR: PACKAGING OPTION  
 (QSE-060-01-XXX-D-LC-TR SHOWN)  
 (DIFFERENT AS SHOWN, OTHERWISE SAME AS FIG 1)  
 (60 POS MAX)  
 (40 POS MAX WITH -GP OPTION)



USER DIRECTION OF UNREELING →  
 POCKET NOT DETAILED



• PROPRIETARY NOTE •  
 THIS DOCUMENT CONTAINS CONFIDENTIAL AND PROPRIETARY INFORMATION AND ALL DESIGN, MANUFACTURING, REPRODUCTION, USE, PATENT RIGHTS AND SALES RIGHTS ARE EXPRESSLY RESERVED BY SAMTEC, INC. THIS DOCUMENT SHALL NOT BE DISCLOSED, IN WHOLE OR PART, TO ANY UNAUTHORIZED PERSON OR ENTITY NOR REPRODUCED, TRANSFERRED OR INCORPORATED IN ANY OTHER PROJECT IN ANY MANNER WITHOUT THE EXPRESS WRITTEN CONSENT OF SAMTEC, INC.



520 PARK EAST BLVD, NEW ALBANY, IN 47150  
 PHONE: 812-944-6733 FAX: 812-948-5047  
 e-Mail info@SAMTEC.com code 55322

DO NOT SCALE DRAWING

SHEET SCALE: 2:1



DESCRIPTION: .8mm DOUBLE ROW HS SOCKET ASSEMBLY

DWG. NO. QSE-XXX-01-XXX-D-XXX

BY: ERIC M 05/20/1999 SHEET 5 OF 5

## Looking for pricing, stock, or lifecycle information?

Click below to explore more details on WIN SOURCE:

-  [View QSE-020-01-L-D-A-K on WIN SOURCE](#)
-  [Samtec Inc. Information](#)

## Optimize Your Supply Chain with WIN SOURCE Solutions

-  Global Sourcing Solution
-  Obsolete Management
-  Cost Control Management
-  Shortage Management
-  Alternative Solution
-  Excess Inventory Management