



THE DATASHEET OF MAX4432ESA



MAXIM

Dual-Supply, 180MHz, 16-Bit Accurate, Ultra-Low Distortion Op Amps

General Description

The MAX4430/MAX4431 single and MAX4432/MAX4433 dual operational amplifiers feature wide bandwidth, 16-bit settling times in 37ns, and low-noise/low-distortion operation. The MAX4430/MAX4432 are compensated for unity gain stability and have a small signal -3dB bandwidth of 180MHz. The MAX4431/MAX4433 are compensated for closed-loop gains of +2 or greater and have a small-signal -3dB bandwidth of 215MHz.

The MAX4430–MAX4433 op amps require only 11mA of supply current per amplifier while achieving 125dB open-loop gain. Voltage noise density is a low $2.8\text{nV}/\sqrt{\text{Hz}}$, and provides 100dB spurious-free dynamic range (SFDR) at 1MHz. These characteristics make these op amps ideal for driving modern high-speed 14- and 16-bit analog-to-digital converters (ADCs).

These high-speed op amps feature wide output voltage swings capable of driving ADCs with $\geq 4\text{V}$ input dynamic range and a high current output drive up to 60mA. Using a voltage feedback architecture, the MAX4430–MAX4433 meet the requirements of many applications that previously depended on current feedback amplifiers.

The MAX4430/MAX4431 are available in a space-saving 5-pin SOT23 package, and the MAX4432/MAX4433 are available in an 8-pin μMAX package.

Applications

High-Speed 14- and 16-Bit ADC Preamplifiers
 Low-Noise Preamplifiers
 IF/RF Amplifiers
 Low-Distortion Active Filters
 High-Performance Receivers
 Precision Instrumentation

Pin Configurations

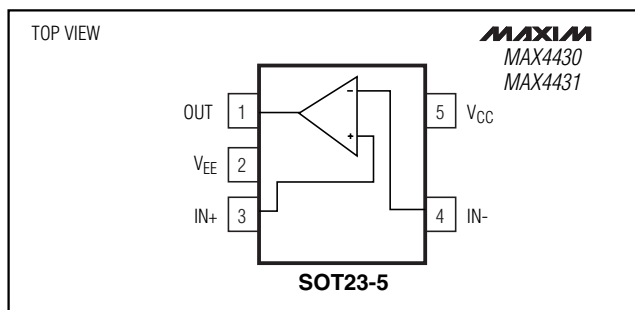

Pin Configurations continued at end of data sheet.

Features

- ◆ 16-Bit Accurate Settling in 37ns (MAX4430/MAX4432)
- ◆ 100dB SFDR at 1MHz, 4Vp-p Output
- ◆ $2.8\text{nV}/\sqrt{\text{Hz}}$ Input Voltage Noise Density
- ◆ 110dB (min) Open-Loop Gain
- ◆ $145\text{V}/\mu\text{s}$ Slew Rate (MAX4431/MAX4433)
- ◆ 60mA High Output Drive
- ◆ Wide Voltage Swing Capable of Driving ADC Inputs with $\geq 4\text{Vp-p}$ Input Dynamic Range
- ◆ Available in Space-Saving Packages
 - 5-pin SOT23 (MAX4430/MAX4431)
 - 8-pin μMAX (MAX4432/MAX4433)

Ordering Information

PART	TEMP. RANGE	PIN-PACKAGE
MAX4430EUK-T	-40°C to +85°C	5 SOT23-5
MAX4430ESA	-40°C to +85°C	8 SO

Ordering Information continued at end of data sheet.

Selector Guide

PART	AMPS	MIN GAIN STABLE (V/V)	BW (MHz)	SETTLING TIME TO 0.0015% (ns)
MAX4430	1	+1	180	37
MAX4431	1	+2	215	63
MAX4432	2	+1	180	37
MAX4433	2	+2	215	63

Typical Operating Circuit

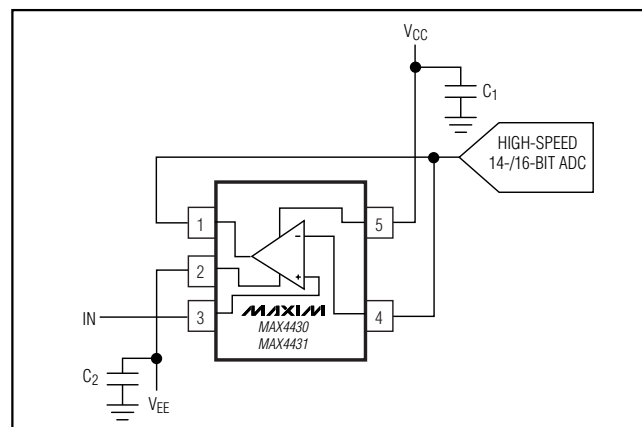
**MAXIM**

Maxim Integrated Products 1

For free samples and the latest literature, visit www.maxim-ic.com or phone 1-800-998-8800.
 For small orders, phone 1-800-835-8769.

MAX4430–MAX4433

Dual-Supply, 180MHz, 16-Bit Accurate, Ultra-Low Distortion Op Amps

ABSOLUTE MAXIMUM RATINGS

Supply Voltage (V_{CC} to V_{EE}).....	+12V	Operating Temperature Range	-40°C to +85°C
Differential Input Voltage	+2V	Junction Temperature	+150°C
Input Voltage Range	($V_{CC} + 0.3V$) to ($V_{EE} - 0.3V$)	Storage Temperature Range	-65°C to +150°C
Output Short-Circuit Duration to V_{CC} or V_{EE}	(Note 1)	Lead Temperature (soldering, 10s)	+300°C
Current Into Any Input Pin	±25mA		
Continuous Power Dissipation ($T_A = +70^\circ\text{C}$)			
5-Pin SOT23 (derate 7.1mW/°C above +70°C).....	571mW		
8-Pin μMAX (derate 4.5mW/°C above +70°C).....	330mW		
8-Pin SO (derate 5.88mW/°C above +70°C).....	471mW		

Note 1: The MAX4430-MAX4433 are not protected for output short-circuit conditions.

Stresses beyond those listed under "Absolute Maximum Ratings" may cause permanent damage to the device. These are stress ratings only, and functional operation of the device at these or any other conditions beyond those indicated in the operational sections of the specifications is not implied. Exposure to absolute maximum rating conditions for extended periods may affect device reliability.

DC ELECTRICAL CHARACTERISTICS

($V_{CC} = +5V$, $V_{EE} = -5V$, $R_L = \infty$, $V_{CM} = 0$, and $T_A = T_{MIN}$ to T_{MAX} , unless otherwise noted. Typical values are at $T_A = +25^\circ\text{C}$.) (Note 2)

PARAMETER	SYMBOL	CONDITIONS	MIN	TYP	MAX	UNITS
Input Common-Mode Voltage Range	V_{CM}	Guaranteed by CMRR test	$V_{EE} + 2.5$		$V_{CC} - 0.9$	V
Input Offset Voltage	V_{OS}			±1.25	±5	mV
Input Offset Voltage Temperature Coefficient	TC_{VOS}			7		$\mu\text{V}/^\circ\text{C}$
Input Offset Voltage Matching		MAX4432/MAX4433		±0.25		mV
Input Bias Current	I_B			11	30	μA
Input Offset Current	I_{OS}			0.35	5	μA
Input Resistance	R_{IN}	Differential ($-10\text{mV} \leq V_{IN} \leq +10\text{mV}$)		12k		Ω
		Common mode ($V_{EE} + 2.5V \leq V_{CM} \leq V_{CC} - 0.9V$)		1M		
Common-Mode Rejection Ratio	CMRR	$V_{EE} + 2.5V \leq V_{CM} \leq V_{CC} - 0.9V$	100	120		dB
Open-Loop Gain	A_{VOL}	$V_{EE} + 2.5 \leq V_{OUT} \leq V_{CC} - 0.9V$; $R_L = 10\text{k}\Omega$ to ground	115	125		dB
		$V_{EE} + 2.5 \leq V_{OUT} \leq V_{CC} - 0.9V$; $R_L = 500\Omega$ to ground	110	125		
Output Voltage Swing	V_{OUT}	$R_L = 10\text{k}\Omega$ to ground	$V_{EE} + 2.5$		$V_{CC} - 0.25$	V
		$R_L = 500\Omega$ to ground	$V_{EE} + 2.6$		$V_{CC} - 0.6$	
Output Current	I_{OUT}	$R_L = 20\Omega$ to ground	±30	±60		mA
Output Short-Circuit Current	I_{SC}	Sinking or sourcing		±100		mA
Power-Supply Rejection Ratio	PSRR-	$V_{EE} = -5.5V$ to $-4.5V$	75	95		dB
	PSRR+	$V_{CC} = +4.5V$ to $+5.5V$				
Operating Supply Voltage Range	V_S	Guaranteed by PSRR test	±4.5		±5.5	V
Quiescent Supply Current (per amplifier)	I_S			11	13.5	mA

Dual-Supply, 180MHz, 16-Bit Accurate, Ultra-Low Distortion Op Amps

MAX4430-MAX4433

AC ELECTRICAL CHARACTERISTICS

($V_{CC} = +5V$, $V_{EE} = -5V$, $R_L = 500\Omega$, $V_{CM} = 0$, $A_{VCL} = +1$, $T_A = +25^\circ C$, unless otherwise noted.)

PARAMETER	SYMBOL	CONDITIONS	MIN	TYP	MAX	UNITS
Small-Signal -3dB Bandwidth	BW _{SS}	V _{OUT} = 100mVp-p, MAX4430/MAX4432		180		MHz
		V _{OUT} = 100mVp-p, MAX4431/MAX4433 (A _{VCL} = +2)		215		
Large-Signal -3dB Bandwidth	BW _{LS}	V _{OUT} = 1Vp-p, MAX4430/MAX4432		45		MHz
		V _{OUT} = 2Vp-p, MAX4430/MAX4432		32		
		V _{OUT} = 2Vp-p, MAX4431/MAX4433 (A _{VCL} = +2)		40		
		V _{OUT} = 4Vp-p, MAX4431/MAX4433 (A _{VCL} = +2)		20		
Bandwidth for 0.1dB Flatness	BW _{0.1dB}	V _{OUT} = 100mVp-p, MAX4430/MAX4432		12		MHz
		V _{OUT} = 100mVp-p, MAX4431/MAX4433 (A _{VCL} = +2)		80		
Slew Rate	SR	V _{OUT} = 2V step, MAX4430/MAX4432		100		V/ μ s
		V _{OUT} = 2V step, MAX4431/MAX4433 (A _{VCL} = +2)		145		
Rise/Fall Time	t _R , t _F	V _{OUT} = 2V step		20		ns
		V _{OUT} = 4V step		40		
Settling Time to 16 Bit (0.0015%)	t _s	V _{OUT} = 0 to 2V step, MAX4430/MAX4432		37		ns
		V _{OUT} = 0 to 2V step, MAX4431/MAX4433 (A _{VCL} = +2)		63		
		V _{OUT} = 0 to 4V step, MAX4430/MAX4432		56		
		V _{OUT} = 0 to 4V step, MAX4431/MAX4433 (A _{VCL} = +2)		140		

Dual-Supply, 180MHz, 16-Bit Accurate, Ultra-Low Distortion Op Amps

AC ELECTRICAL CHARACTERISTICS (continued)

($V_{CC} = +5V$, $V_{EE} = -5V$, $R_L = 500\Omega$, $V_{CM} = 0$, $A_{VCL} = +1$, $T_A = +25^\circ C$, unless otherwise noted.)

PARAMETER	SYMBOL	CONDITIONS	MIN	TYP	MAX	UNITS
Output "Glitch" Settling to 16-Bit (0.0015%)		5pF load; C_L charged from 0 to 4V		24		ns
Output Overload Recovery Time		50% overdrive, settling to 10% accuracy		95		ns
AC Common-Mode Rejection Ratio		$f = 100kHz$		-84		dB
AC Power-Supply Rejection Ratio		$f = 100kHz$		-77		dB
Spurious-Free Dynamic Range	SFDR	$V_{OUT} = 2Vp-p$ centered at 0V, $f_C = 100kHz$		-110		dBc
		$V_{OUT} = 2Vp-p$ centered at 0V, $f_C = 1MHz$		-105		
		$V_{OUT} = 4Vp-p$ centered at 0V, $f_C = 100kHz$		-105		
		$V_{OUT} = 4Vp-p$ centered at 0V, $f_C = 1MHz$		-103		
		$V_{OUT} = 2Vp-p$ centered at 1V, $f_C = 100kHz$		-112		
		$V_{OUT} = 2Vp-p$ centered at 1V, $f_C = 1MHz$		-107		
		$V_{OUT} = 4Vp-p$ centered at 2V, $f_C = 100kHz$		-106		
		$V_{OUT} = 4Vp-p$ centered at 2V, $f_C = 1MHz$		-100		
		$V_{OUT} = 4Vp-p$ centered at 2V, $f_C = 1MHz$ ($R_L = 1k\Omega$)		-99		
		$V_{OUT} = 4Vp-p$ centered at 2V, $f_C = 1MHz$ ($R_L = 10k\Omega$)		-100		
Input Noise Voltage Density	e_n	$f = 100kHz$		2.8		nV/\sqrt{Hz}
Input Noise Current Density	i_n	$f = 100kHz$		1.8		pA/\sqrt{Hz}
Input Capacitance	C_{IN}			2.5		pF
Maximum Capacitive Load Without Sustained Oscillations				47		pF
Output Impedance	Z_{OUT}	$f = 1MHz$		0.2		Ω
Crosstalk		MAX4432/MAX4433 $f_C = 1MHz$		-125		dB

Note 2: All devices are 100% production tested at $T_A = +25^\circ C$. All temperature limits are guaranteed by design.

Dual-Supply, 180MHz, 16-Bit Accurate, Ultra-Low Distortion Op Amps

Typical Operating Characteristics

($V_{CC} = +5V$, $V_{EE} = -5V$, $R_L = 500\Omega$, $C_L = 0pF$, $T_A = +25^\circ C$, unless otherwise noted.)

MAX4430-MAX4433

MAX4430/MAX4432
SMALL-SIGNAL GAIN vs. FREQUENCY
($A_{VCL} = +1V/V$)

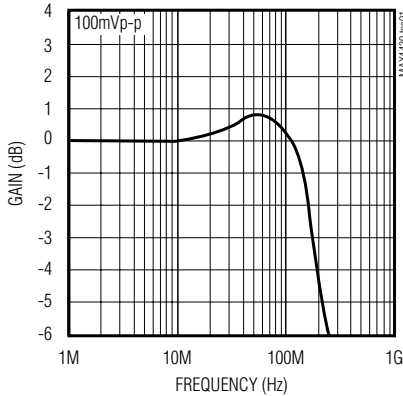

MAX4431/MAX4433
SMALL-SIGNAL GAIN vs. FREQUENCY
($A_{VCL} = +2V/V$)

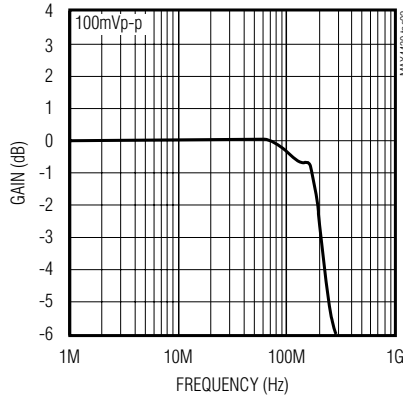

MAX4430/MAX4432
GAIN FLATNESS vs. FREQUENCY
($A_{VCL} = +1V/V$)

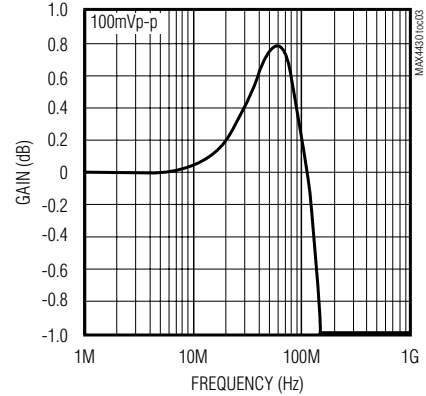

MAX4431/MAX4433
GAIN FLATNESS vs. FREQUENCY
($A_{VCL} = +2V/V$)

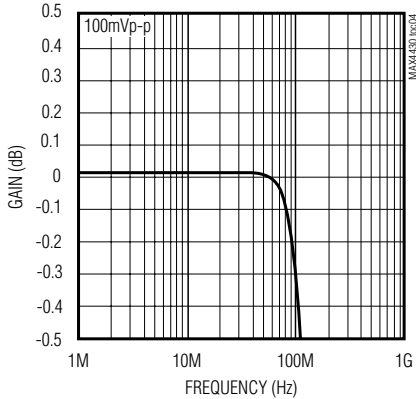

MAX4430/MAX4432
LARGE-SIGNAL GAIN vs. FREQUENCY
($A_{VCL} = +1V/V$)

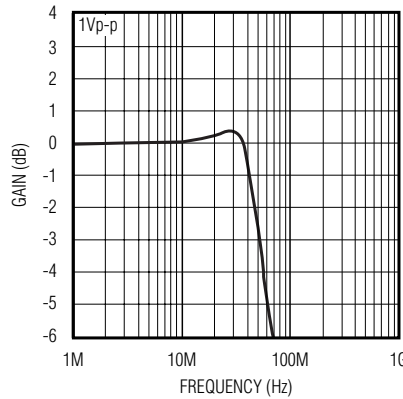

MAX4431/MAX4433
LARGE-SIGNAL GAIN vs. FREQUENCY
($A_{VCL} = +2V/V$)

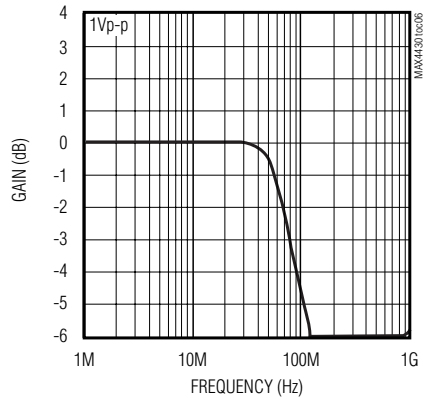

MAX4430/MAX4432
SMALL-SIGNAL PULSE RESPONSE
($A_{VCL} = +1V/V$)

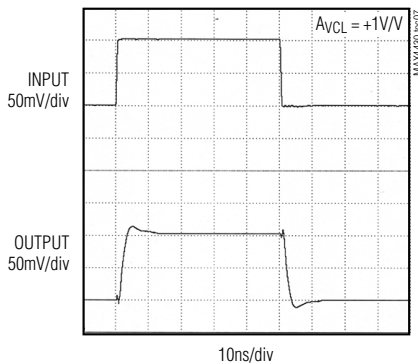

MAX4431/MAX4433
SMALL-SIGNAL PULSE RESPONSE
($A_{VCL} = +2V/V$)

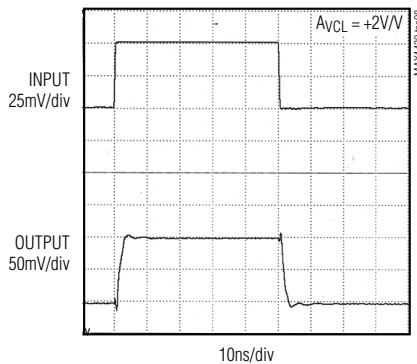

MAX4430/MAX4432
LARGE-SIGNAL PULSE RESPONSE
($A_{VCL} = +1V/V$)

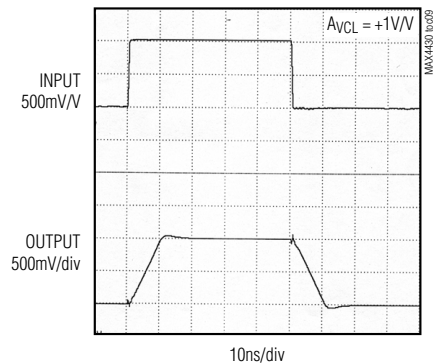

Dual-Supply, 180MHz, 16-Bit Accurate, Ultra-Low Distortion Op Amps

Typical Operating Characteristics (continued)

($V_{CC} = +5V$, $V_{EE} = -5V$, $R_L = 500\Omega$, $C_L = 0pF$, $T_A = +25^\circ C$, unless otherwise noted.)

**MAX4431/MAX4433
LARGE-SIGNAL PULSE RESPONSE**

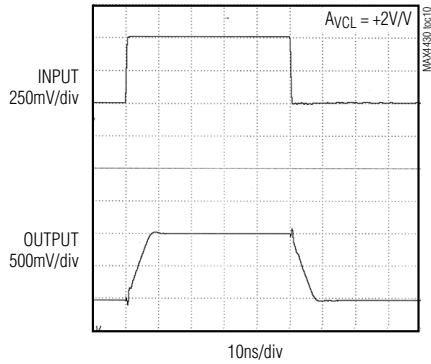

**MAX4430/MAX4432
SMALL-SIGNAL PULSE RESPONSE**

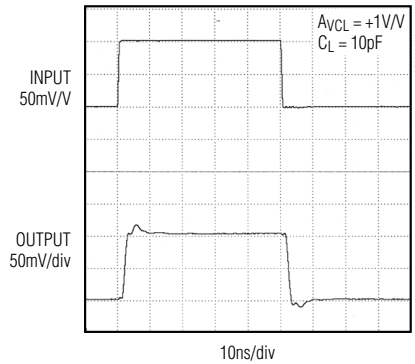

**MAX4431/MAX4433
SMALL-SIGNAL PULSE RESPONSE**

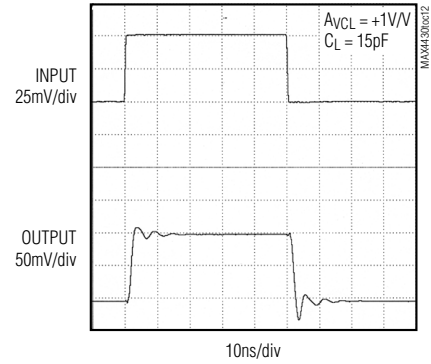

**MAX4430/MAX4432
LARGE-SIGNAL PULSE RESPONSE**

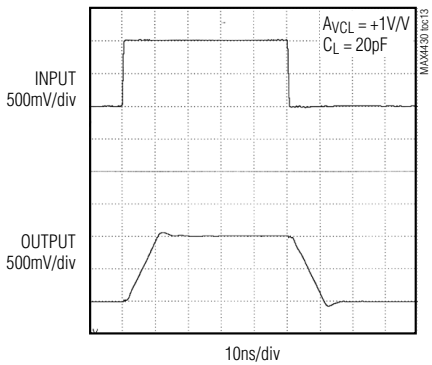

**MAX4431/MAX4433
LARGE-SIGNAL PULSE RESPONSE**

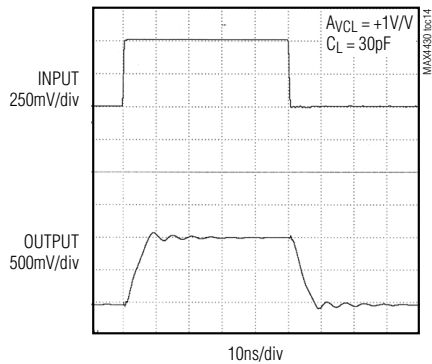

**POWER-SUPPLY REJECTION RATIO
vs. FREQUENCY**

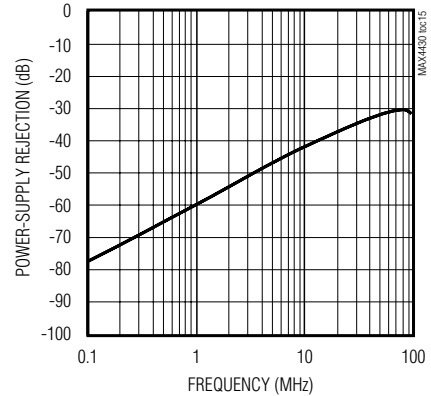

**COMMON-MODE REJECTION RATIO
vs. FREQUENCY**

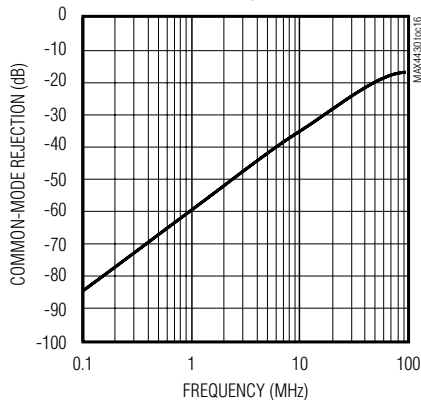

**OUTPUT ISOLATION RESISTANCE
vs. CAPACITIVE LOAD**

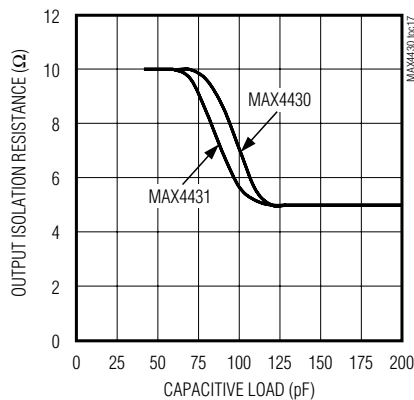

**CLOSED-LOOP OUTPUT IMPEDANCE
vs. FREQUENCY**

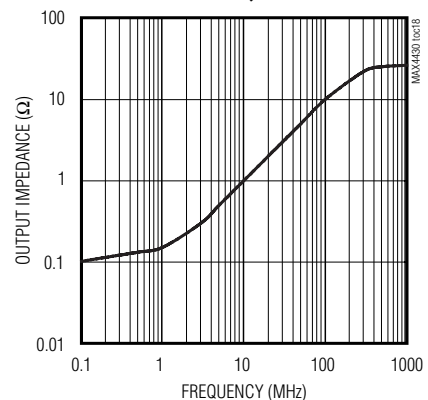

Dual-Supply, 180MHz, 16-Bit Accurate, Ultra-Low Distortion Op Amps

Typical Operating Characteristics (continued)

($V_{CC} = +5V$, $V_{EE} = -5V$, $R_L = 500\Omega$, $C_L = 0pF$, $T_A = +25^\circ C$, unless otherwise noted.)

MAX4430-MAX4433

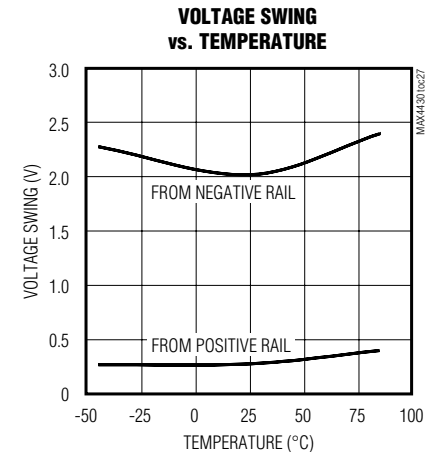
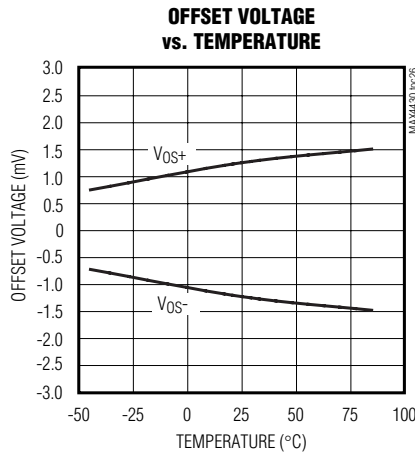
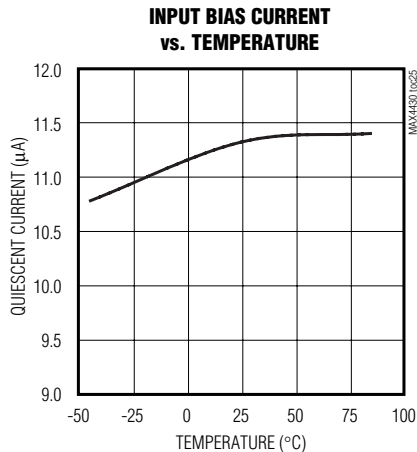
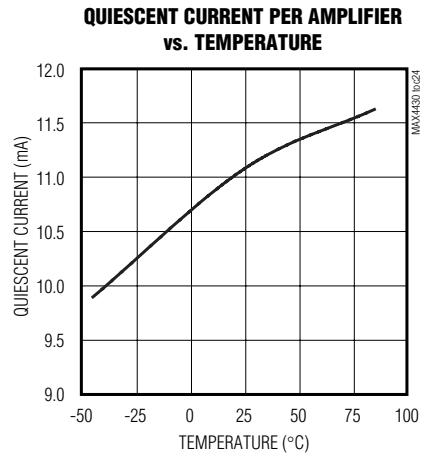
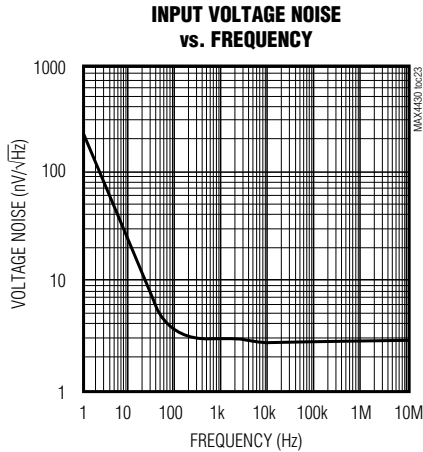
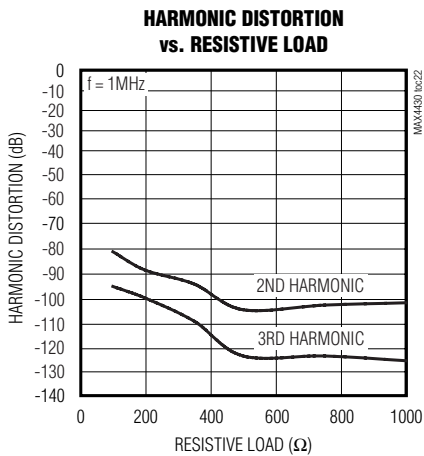
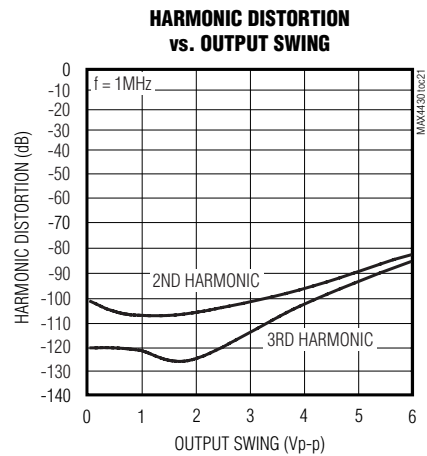
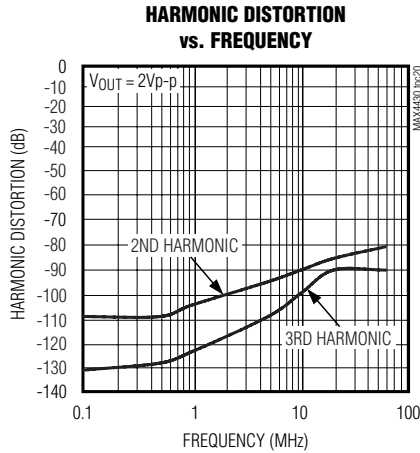
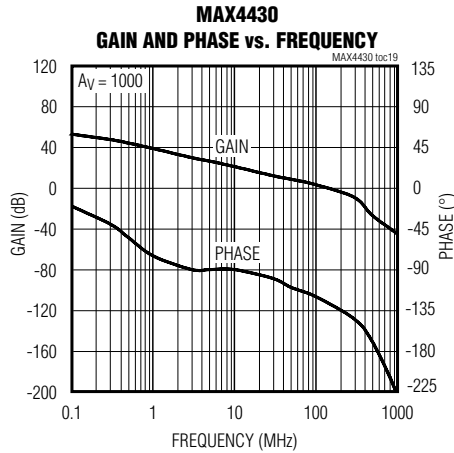

Dual-Supply, 180MHz, 16-Bit Accurate, Ultra-Low Distortion Op Amps

Typical Operating Characteristics (continued)

($V_{CC} = +5V$, $V_{EE} = -5V$, $R_L = 500\Omega$, $C_L = 0pF$, $T_A = +25^\circ C$, unless otherwise noted.)

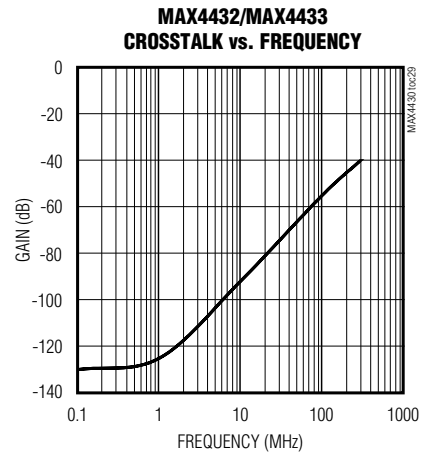
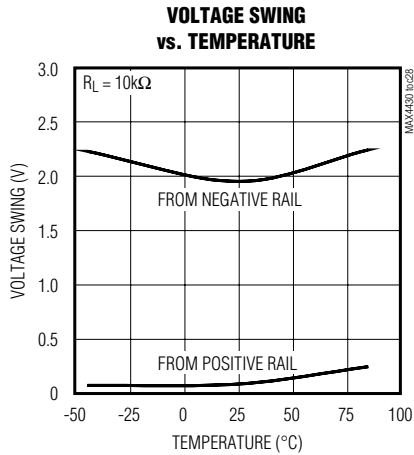

Pin Description

PIN		NAME	FUNCTION
MAX4430/MAX4431			
5 SOT23	8 SO		
1	6	OUT	Output
2	4	V_{EE}	Negative Power Supply
3	3	IN+	Noninverting Input
4	2	IN-	Inverting Input
5	7	V_{CC}	Positive Power Supply
—	1, 5, 8	N.C.	No Connection. Not internally connected.

PIN		NAME	FUNCTION
MAX4432/MAX4433			
8 SO/8 μ MAX			
1		OUTA	Amplifier A Output
2		INA-	Amplifier A Inverting Input
3		INA+	Amplifier A Noninverting Input
4		V_{EE}	Negative Power Supply
5		INB+	Amplifier B Noninverting Input
6		INB-	Amplifier B Inverting Input
7		OUTB	Amplifier B Output
8		V_{CC}	Positive Power Supply

Dual-Supply, 180MHz, 16-Bit Accurate, Ultra-Low Distortion Op Amps

Detailed Description

The MAX4430-MAX4433 are wide-bandwidth, ultra-low-distortion, voltage-feedback amplifiers. The MAX4430/MAX4432 are internally compensated for unity gain. The MAX4431/MAX4433 are internally compensated for gains of +2V/V or greater.

These amplifiers have ultra-fast 37ns (MAX4430/MAX4432) 16-bit settling times, 100dB SFDR at 1MHz, and 4Vp-p output swing with minimum 110dB open-loop gain.

High-Speed ADC Input Driver Application

The MAX4430-MAX4433 op amps are ideal for driving high-speed 14- to 16-bit ADCs. In most cases, these ADCs operate with a charge balance scheme, with capacitive loads internally switched on and off from the input. The driver used must withstand these changing capacitive loads while holding the signal amplitude stability consistent with the ADC's resolution and, at the same time, have a frequency response compatible with the sampling speed of the ADC (Figure 1).

Inverting and Noninverting Configurations

The circuits typically used for the inverting and non-inverting configurations of the MAX4430-MAX4433 are shown in Figures 2a and 2b. The minimum unconditionally stable gain values are 1 for the MAX4430/MAX4432

and 2 for the MAX4431/MAX4433. Use care in selecting the value for the resistor marked R_S in both circuits. From dynamic stability considerations (based on the part's frequency response and the input capacitance of the MAX4430-MAX4433), the maximum recommended value for R_S is 500Ω. In general, lower R_S values will yield a higher bandwidth and better dynamic stability, at the cost of higher power consumption, higher power dissipation in the IC, and reduced output drive availability. For a minimum R_S value, take into consideration that the current indicated as I_F is supplied by the output stage and must be discounted from the maximum output current to calculate the maximum current available to the load. I_F can be found using the following equation:

$$I_F = V_{IN(MAX)} / R_S$$

If DC thermal stability is an important design concern, the Thevenin resistance seen by both inputs at DC must be balanced. This includes the resistance of the signal source and termination resistors if the amplifier signal input is fed from a transmission line. The capacitance associated with the feedback resistors must also be considered as a possible limitation to the available bandwidth or to the dynamic stability. Only resistors with small parallel capacitance specifications should be considered.

Applications Information

Layout and Power-Supply Bypassing

The MAX4430-MAX4433 have wide bandwidth and consequently require careful board layout. To realize the full AC performance of these high-speed amplifiers, pay careful attention to power-supply bypassing and board layout. The PC board should have a large low-impedance ground plane that is as free of voids as possible. Do not use commercial breadboards. Keep signal lines as short and straight as possible. Observe high-frequency bypassing techniques to maintain the

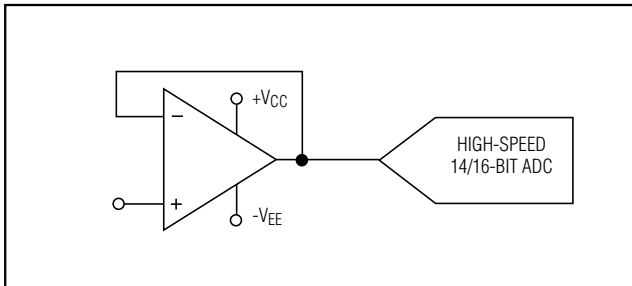

Figure 1. Typical Application Circuit

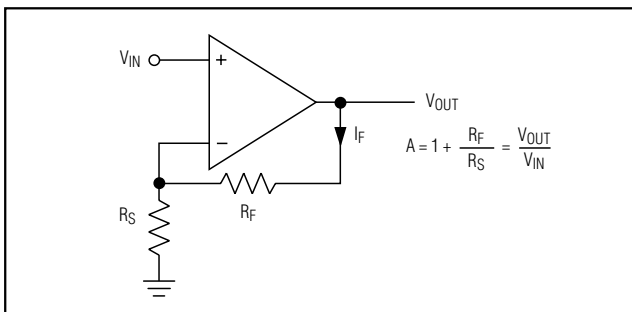

Figure 2a. Noninverting Configuration

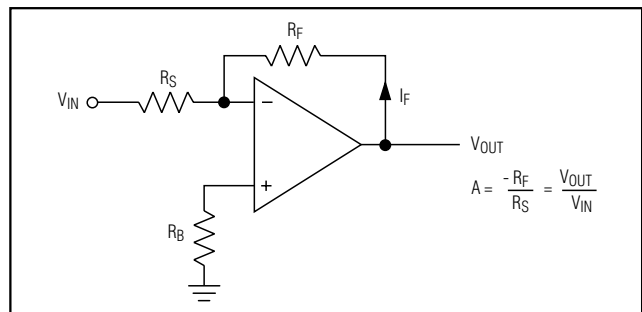

Figure 2b. Inverting Configuration

Dual-Supply, 180MHz, 16-Bit Accurate, Ultra-Low Distortion Op Amps

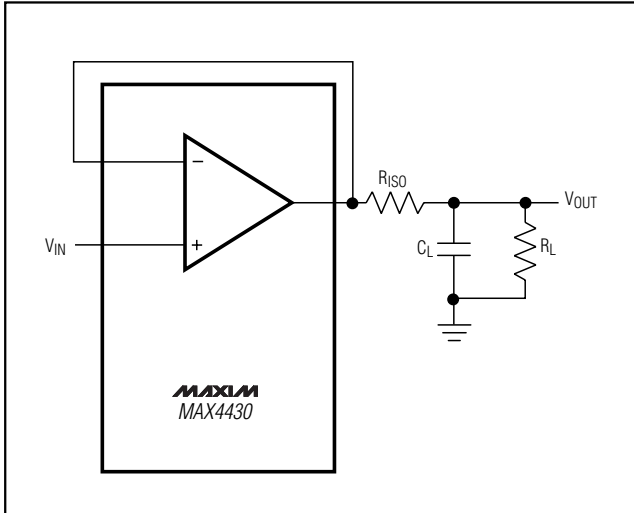

Figure 3. Capacitive-Load Driving Circuit

amplifier's accuracy and stability. In general, use surface-mount components since they have shorter bodies and lower parasitic reactance. This will result in improved performance over through-hole components. The bypass capacitors should include 1nF and/or 0.1μF surface-mount ceramic capacitors between each supply pin and the ground plane, located as close to the package as possible. Place a 10μF tantalum capacitor at the power supply's point of entry to the PC board to ensure the integrity of the incoming supplies. Input termination resistors and output back-termination resistors, if used, should be surface-mount types and should be placed as close to the IC pins as possible.

Driving Capacitive Loads

MAX4430-MAX4433 can drive capacitive loads. However, excessive capacitive loads may cause ringing or instability at the output as phase margin is reduced. Adding a small isolation resistor in series with the output capacitive load helps reduce the ringing but slightly increases gain error (see *Typical Operating Characteristics* and Figure 3).

Ordering Information (continued)

PART	TEMP. RANGE	PIN-PACKAGE
MAX4431EUK-T	-40°C to +85°C	5 SOT23-5
MAX4431ESA	-40°C to +85°C	8 SO
MAX4432EUA	-40°C to +85°C	8 μMAX
MAX4432ESA	-40°C to +85°C	8 SO
MAX4433EUA	-40°C to +85°C	8 μMAX
MAX4433ESA	-40°C to +85°C	8 SO

Pin Configurations (continued)

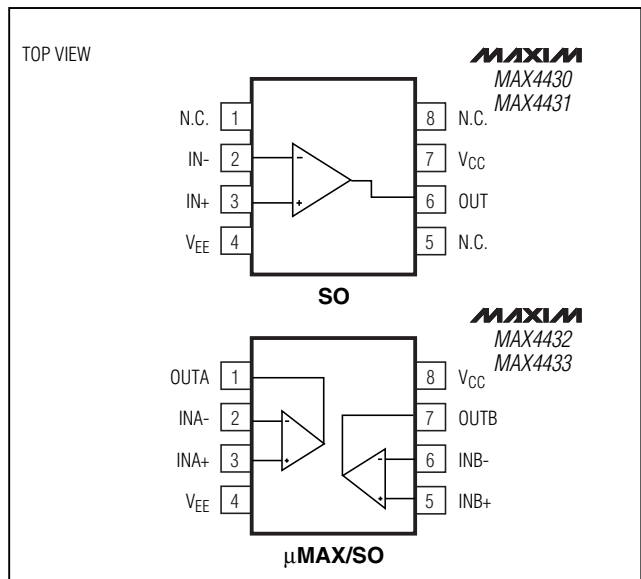

Chip Information

TRANSISTOR COUNT: MAX4430/MAX4431: 103

MAX4432/MAX4433: 248

Dual-Supply, 180MHz, 16-Bit Accurate, Ultra-Low Distortion Op Amps

Package Information

MAX4430-MAX4433

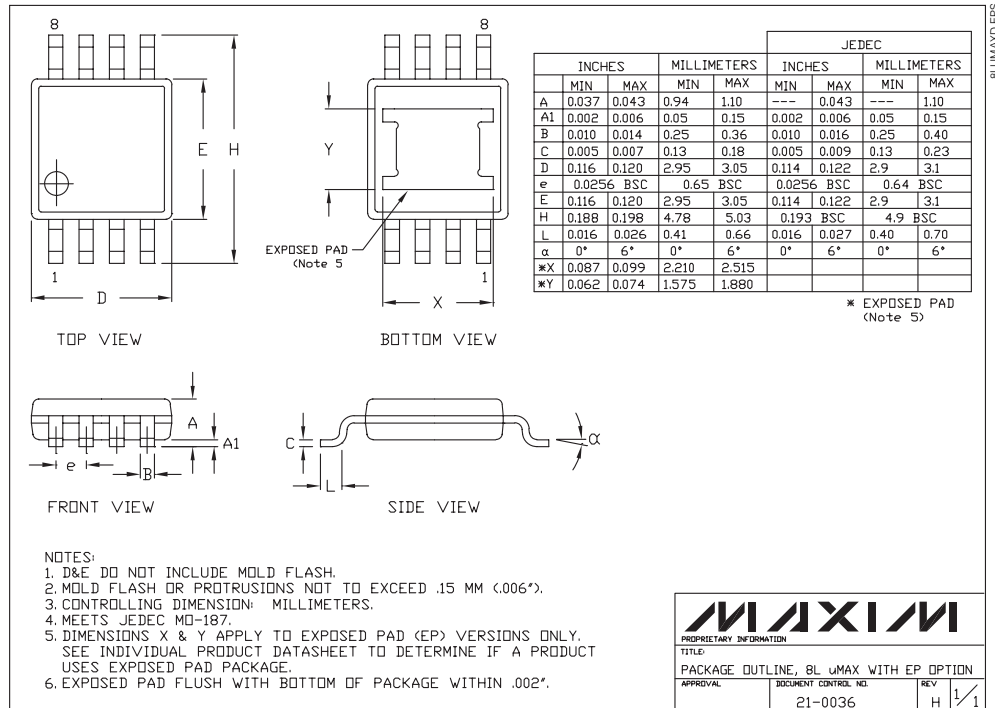
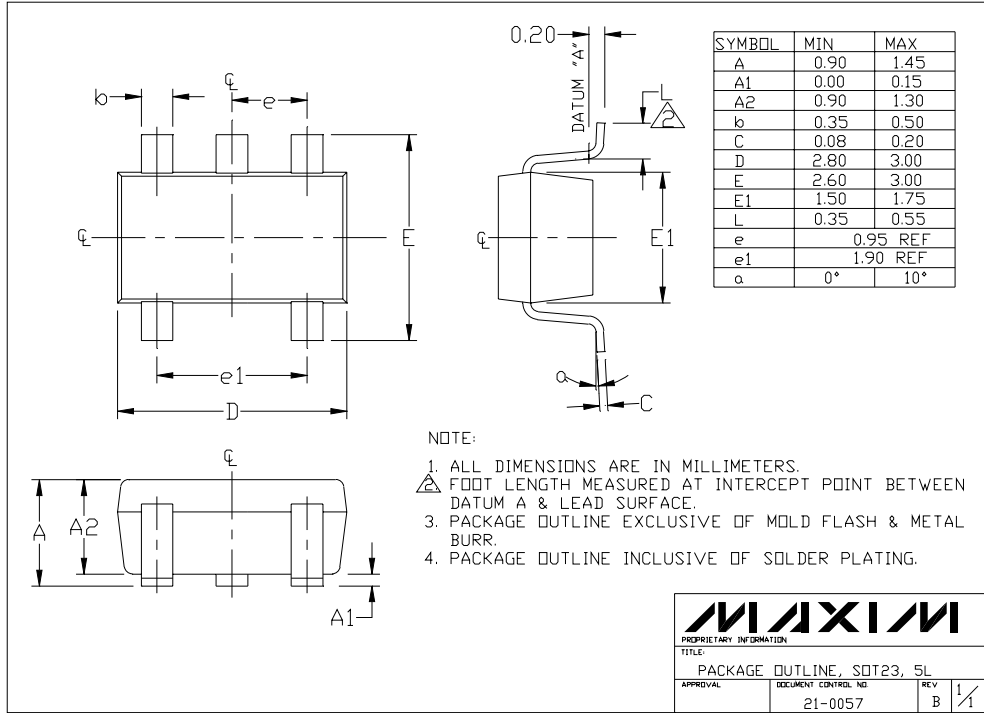

Dual-Supply, 180MHz, 16-Bit Accurate, Ultra-Low Distortion Op Amps

Package Information (continued)

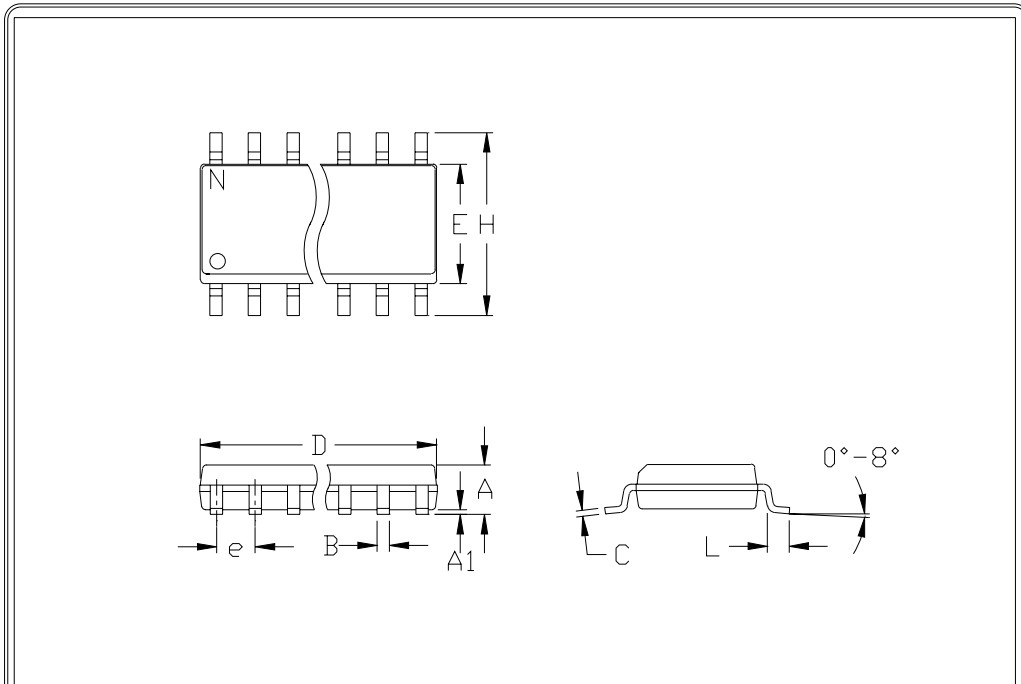

	INCHES		MILLIMETERS	
	MIN	MAX	MIN	MAX
A	0.053	0.069	1.35	1.75
A1	0.004	0.010	0.10	0.25
B	0.014	0.019	0.35	0.49
C	0.007	0.010	0.19	0.25
e	0.050		1.27	
E	0.150	0.157	3.80	4.00
H	0.228	0.244	5.80	6.20
h	0.010	0.020	0.25	0.50
L	0.016	0.050	0.40	1.27

	INCHES		MILLIMETERS		N	MS012
	MIN	MAX	MIN	MAX		
D	0.189	0.197	4.80	5.00	8	A
D	0.337	0.344	8.55	8.75	14	B
D	0.386	0.394	9.80	10.00	16	C

NOTES:

1. D&E DO NOT INCLUDE MOLD FLASH
2. MOLD FLASH OR PROTRUSIONS NOT TO EXCEED .15mm (.006")
3. LEADS TO BE COPLANAR WITHIN .102mm (.004")
4. CONTROLLING DIMENSION: MILLIMETER
5. MEETS JEDEC MS012-XX AS SHOWN IN ABOVE TABLE
6. N = NUMBER OF PINS

 <small>120 SAN GABRIEL DR. SUNNYVALE CA 94086 FAX (408) 737 7154 PROPRIETARY INFORMATION</small>	PACKAGE FAMILY OUTLINE: SOIC .150"	$\frac{1}{1}$	21-0041 A <small>DOCUMENT CONTROL NUMBER REV</small>
------------------------------------------------------------------------------------------------------------------------------------------------------------------------------------------------------	------------------------------------	---------------	---------------------------------------------------------

Maxim cannot assume responsibility for use of any circuitry other than circuitry entirely embodied in a Maxim product. No circuit patent licenses are implied. Maxim reserves the right to change the circuitry and specifications without notice at any time.

12 _____ **Maxim Integrated Products, 120 San Gabriel Drive, Sunnyvale, CA 94086 408-737-7600**

Looking for pricing, stock, or lifecycle information?

Click below to explore more details on WIN SOURCE:

- ⊖ [View MAX4432ESA on WIN SOURCE](#)
- ⊖ [Maxim Integrated Information](#)

Optimize Your Supply Chain with WIN SOURCE Solutions

- ✓ Global Sourcing Solution
- ✓ Obsolete Management
- ✓ Cost Control Management
- ✓ Shortage Management
- ✓ Alternative Solution
- ✓ Excess Inventory Management