



**THE DATASHEET OF  
LM4970SDX/NOPB**



**LM4970 Boomer® Audio Power Amplifier Series Audio Synchronized Color LED Driver**Check for Samples: [LM4970](#)**FEATURES**

- **Audio Synchronized Color LED Driver**
- **User Defined LED Pattern, Color, and Intensity Capability**
- **Programmable:**
  - **LED Drive Current**
  - **PWM Frequency**
  - **High Pass Filter Frequency Select**
  - **Audio Input Signal Gain**
- **Eliminates External LED Current Limiting Resistors**
- **I<sup>2</sup>C Compatible Interface**
- **Ultra Low Shutdown Current**

**APPLICATIONS**

- **Cell Phones**
- **Portable MP3, CD, DVD, AAC players**
- **PDA's**

**KEY SPECIFICATIONS**

- **LED Drive Current per Channel (V<sub>DD</sub> = 5V): 42mA (2X Setting)**
- **Shutdown Current, V<sub>DD</sub> = 5V: 1.5µA (Typ)**

**DESCRIPTION**

The LM4970 is a LED driver with an audio synchronization mode that virtually eliminates the need for real time software processing for LED lighting effects. The LM4970 includes three individual PWM color LED drivers that provide up to 42mA of current drive for each PWM LED output.

The LM4970 features an audio synchronization mode where the audio input signal that is mixed in from three audio inputs is filtered into three frequency bands, with each frequency band assigned to a specific PWM LED driver.

The PWM LED drivers can also be directly programmed through an I<sup>2</sup>C compatible interface for applications where user defined LED pattern, color, and intensity programmability is a priority.

The LM4970 also features an audio input gain control which allows the user to increase the gain if the audio input signal does not create a bright enough effect on the LEDs. The LM4970 is a feature rich LED driver that is available in a space saving 14 pin non-pullback WSON package.



Please be aware that an important notice concerning availability, standard warranty, and use in critical applications of Texas Instruments semiconductor products and disclaimers thereto appears at the end of this data sheet.

All trademarks are the property of their respective owners.

**Block Diagram**

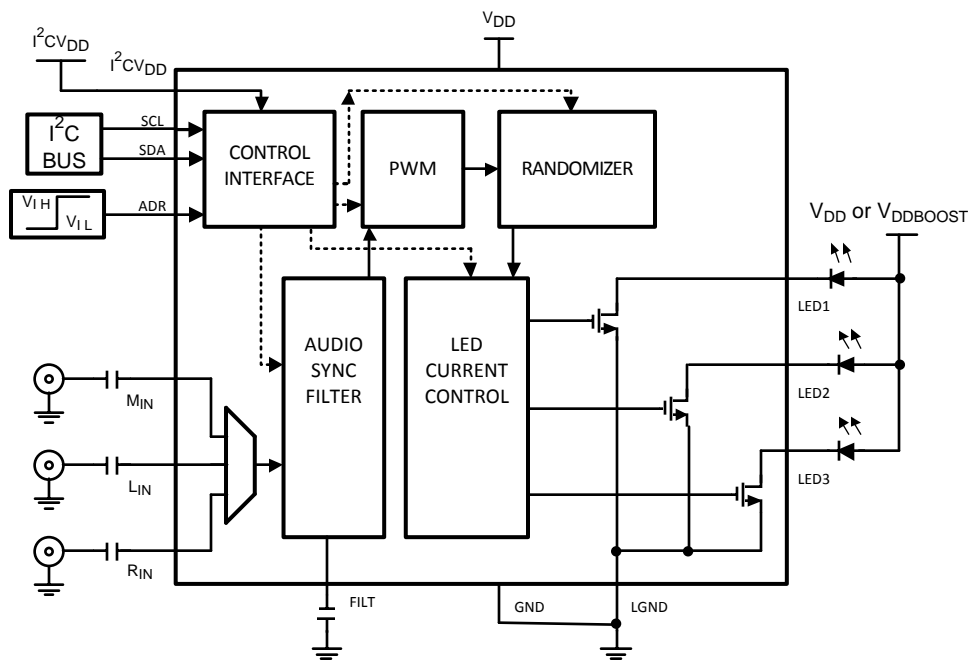

**Figure 1. Block Diagram**

**Connection Diagram**

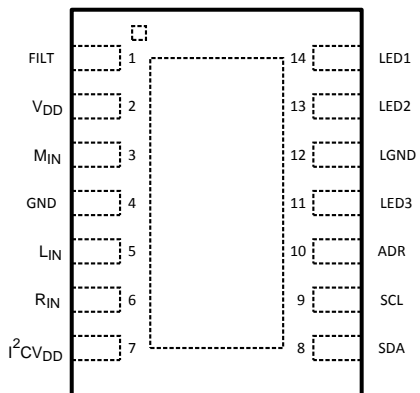

**Figure 2. 14 pin NHK Package (Top View)  
See Package Number NHK0014A**

**PIN DESCRIPTIONS**

Pin	Name	Pin Description
1	FILT	Low Pass Filter Input
2	V <sub>DD</sub>	Power Supply Pin
3	M <sub>IN</sub>	Mono Audio Input
4	GND	Ground
5	L <sub>IN</sub>	Left Audio Input
6	R <sub>IN</sub>	Right Audio Input
7	I <sup>2</sup> C V <sub>DD</sub>	I <sup>2</sup> C Interface Power Supply
8	SDA	I <sup>2</sup> C Data
9	SCL	I <sup>2</sup> C Clock
10	ADR	I <sup>2</sup> C Address Select
11	LED3	LED output 3
12	LGND	LED ground
13	LED2	LED output 2
14	LED1	LED output 1



These devices have limited built-in ESD protection. The leads should be shorted together or the device placed in conductive foam during storage or handling to prevent electrostatic damage to the MOS gates.

**Absolute Maximum Ratings**<sup>(1)(2)(3)</sup>

Supply Voltage	6.0V	
Storage Temperature	–65°C to +150°C	
Input Voltage	–0.3V to V <sub>DD</sub> + 0.3V	
Power Dissipation <sup>(4)</sup>	Internally Limited	
ESD Susceptibility <sup>(5)</sup>	2000V	
ESD Susceptibility <sup>(6)</sup>	200V	
ESD Susceptibility <sup>(7)</sup>	100V	
Junction Temperature	150°C	
Thermal Resistance	$\theta_{JA}$ (NHK0014A) <sup>(8)</sup>	57°C/W
	$\theta_{JC}$ (NHK0014A)	12°C/W

- (1) All voltages are measured with respect to the GND pin unless otherwise specified.
- (2) Absolute Maximum Ratings indicate limits beyond which damage to the device may occur. Operating Ratings indicate conditions for which the device is functional but do not ensure specific performance limits. Electrical Characteristics state DC and AC electrical specifications under particular test conditions which specify specific performance limits. This assumes that the device is within the Operating Ratings. Specifications are not ensured for parameters where no limit is given, however, the typical value is a good indication of device performance.
- (3) If Military/Aerospace specified devices are required, please contact the Texas Instruments Sales Office/Distributors for availability and specifications.
- (4) The maximum power dissipation must be derated at elevated temperatures and is dictated by T<sub>JMAX</sub>,  $\theta_{JA}$ , and the ambient temperature, T<sub>A</sub>. The maximum allowable power dissipation is P<sub>DMAX</sub> = (T<sub>JMAX</sub> - T<sub>A</sub>) /  $\theta_{JA}$  or the number given in Absolute Maximum Ratings, whichever is lower.
- (5) Human body model, 100pF discharged through a 1.5k $\Omega$  resistor.
- (6) Machine Model, 200pF–220pF discharged through all pins, except pins 13 and 14.
- (7) Machine Model, 200pF–220pF discharge through pins 13 and 14 (LED1 and LED2).
- (8) The given  $\theta_{JA}$  is for an LM4970SD mounted on a PCB with a 2in<sup>2</sup> area of 1oz printed circuit board copper ground plane.

**Operating Ratings**

Temperature Range (T <sub>MIN</sub> ≤ T <sub>A</sub> ≤ T <sub>MAX</sub> )	–40°C ≤ T <sub>A</sub> ≤ +85°C
Supply Voltage	2.7V ≤ V <sub>DD</sub> ≤ 5.5V <sup>(1)</sup>
	2.5V ≤ I <sup>2</sup> C V <sub>DD</sub> ≤ 5.5V

- (1) V<sub>DD</sub> may be used to power the LEDs. It may be necessary to drive the LEDs from a boost (V<sub>DDBOOST</sub>) found within the system.

## Control Interface Electrical Characteristics<sup>(1)(2)</sup>

The following specifications apply for  $3V \leq V_{DD} \leq 5V$  unless otherwise specified. Limits apply for  $T_A = 25^\circ\text{C}$ .

Symbol	Parameter	Conditions	LM4970		Units (Limits)
			Typical <sup>(3)</sup>	Limits <sup>(4)(5)</sup>	
$t_1$	SCL period			2.5	$\mu\text{s}$ (min)
$t_2$	SDA Setup Time			100	ns (min)
$t_3$	SDA Stable Time			0	ns (min)
$t_4$	Start Condition Time			100	ns (min)
$t_5$	Stop Condition Time			100	ns (min)
$V_{IH}$	Digital Input High Voltage			$0.7 \times I^2CV_{DD}$	V (min)
$V_{IL}$	Digital Input Low Voltage			$0.3 \times I^2CV_{DD}$	V (max)

- (1) All voltages are measured with respect to the GND pin unless otherwise specified.
- (2) Absolute Maximum Ratings indicate limits beyond which damage to the device may occur. Operating Ratings indicate conditions for which the device is functional but do not ensure specific performance limits. Electrical Characteristics state DC and AC electrical specifications under particular test conditions which specify specific performance limits. This assumes that the device is within the Operating Ratings. Specifications are not ensured for parameters where no limit is given, however, the typical value is a good indication of device performance.
- (3) Typicals are measured at  $+25^\circ\text{C}$  and represent the parametric norm.
- (4) Limits are ensured to AOQL (Average Outgoing Quality Level).
- (5) Datasheet min/max specification limits are ensured by design, test, or statistical analysis.

## Color LED Driver Electrical Characteristics $V_{DD} = 5.0V$ <sup>(1)(2)(3)</sup>

The following specifications apply for  $V_{DD} = 5.0V$  unless otherwise specified. Limits apply for  $T_A = 25^\circ\text{C}$ .

Symbol	Parameter	Conditions	LM4970		Units (Limits)
			Typical <sup>(4)</sup>	Limits <sup>(5)(6)</sup>	
$I_{DDRGB}$	Supply Current		2.5	4	mA (max)
$I_{SDRGB}$	Shutdown Current	Shutdown Mode	1.5	3.5	$\mu\text{A}$ (max)
$I_{LED}$	LED Drive Current	.66X current drive setting	14		mA
		1X current drive setting	21		mA
		1.33X current drive setting	30		mA
		2X current drive setting	42	23	mA (min)
$f_{PWM}$	PWM Frequency	$PWM\_F<1:0> = '01'$	60		Hz
	Input Signal Level Gain Control	Maximum setting	12		dB
		Minimum setting	-11		dB

- (1) All voltages are measured with respect to the GND pin unless otherwise specified.
- (2) Absolute Maximum Ratings indicate limits beyond which damage to the device may occur. Operating Ratings indicate conditions for which the device is functional but do not ensure specific performance limits. Electrical Characteristics state DC and AC electrical specifications under particular test conditions which specify specific performance limits. This assumes that the device is within the Operating Ratings. Specifications are not ensured for parameters where no limit is given, however, the typical value is a good indication of device performance.
- (3) Shutdown current and supply current are measured in a normal room environment. All digital input pins are connected to  $I^2CV_{DD}$ .
- (4) Typicals are measured at  $+25^\circ\text{C}$  and represent the parametric norm.
- (5) Limits are ensured to AOQL (Average Outgoing Quality Level).
- (6) Datasheet min/max specification limits are ensured by design, test, or statistical analysis.

## Color LED Driver Electrical Characteristics $V_{DD} = 3.0V^{(1)(2)(3)}$

The following specifications apply for  $V_{DD} = 3.0V$  unless otherwise specified. Limits apply for  $T_A = 25^\circ C$ .

Symbol	Parameter	Conditions	LM4970		Units (Limits)
			Typical <sup>(4)</sup>	Limits <sup>(5)(6)</sup>	
$I_{DDRGB}$	Supply Current		2.2	3	mA (max)
$I_{SDRGB}$	Shutdown Current <sup>(3)</sup>	Shutdown Mode	0.5	2	$\mu A$ (max)
$I_{LED}$	LED Drive Current	.66X current drive setting	12		mA
		1X current drive setting	18		mA
		1.33X current drive setting	27		mA
		2X current drive setting	35	21	mA (min)
$f_{PWM}$	PWM Frequency	PWM_F<1:0> = '01'	60		Hz
	Input Signal Level Gain Control	Maximum setting	12		dB
		Minimum setting	-11		dB

- (1) All voltages are measured with respect to the GND pin unless otherwise specified.
- (2) Absolute Maximum Ratings indicate limits beyond which damage to the device may occur. Operating Ratings indicate conditions for which the device is functional but do not ensure specific performance limits. Electrical Characteristics state DC and AC electrical specifications under particular test conditions which specify specific performance limits. This assumes that the device is within the Operating Ratings. Specifications are not ensured for parameters where no limit is given, however, the typical value is a good indication of device performance.
- (3) Shutdown current and supply current are measured in a normal room environment. All digital input pins are connected to  $I^2CV_{DD}$ .
- (4) Typical values are measured at  $+25^\circ C$  and represent the parametric norm.
- (5) Limits are ensured to AOQL (Average Outgoing Quality Level).
- (6) Datasheet min/max specification limits are ensured by design, test, or statistical analysis.

## External Components Description

Components		Functional Description
1.	$C_i$	This is the input coupling capacitor. It blocks the DC voltage and couples the input signal to the amplifier's input terminals. $C_{IN}$ also creates a highpass filter with an internal $20k\Omega$ resistor at $f_c = 1/(2\pi \cdot 20000 \cdot C_i)$ .
2.	$C_S$	This is the supply bypass capacitor. It filters the supply voltage applied to the $V_{DD}$ pin and helps reduce the noise at the $V_{DD}$ pin.
3.	$C_{filt}$	This capacitor creates a low pass filter with an internal $4k\Omega$ resistor at $f_c = 1/(2\pi \cdot 4000 \cdot C_{filt})$ . This pole set at $f_c$ determines the high cutoff frequency for the low band PWM color LED driver output, LED1.

## Typical Performance Characteristics<sup>(1)</sup>

**Audio Sync LED Frequency Response**  
(Left - lowband, Mid - midband, Right - highband)  
(Cfilt = 0.047 $\mu$ F, HPF = 3.5kHz setting)

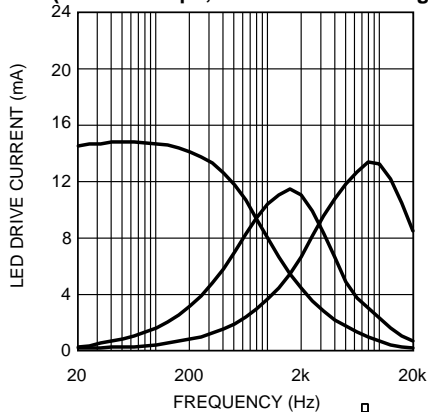

Figure 3.

**Audio Sync LED Frequency Response**  
(Left - lowband, Mid - midband, Right - highband)  
(Cfilt = 0.068 $\mu$ F, HPF = 3.5kHz setting)

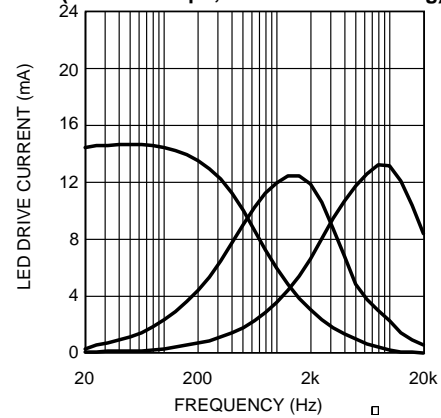

Figure 4.

**Audio Sync LED Frequency Response**  
(Left - lowband, Mid - midband, Right - highband)  
(Cfilt = 0.1 $\mu$ F, HPF = 3.5kHz setting)

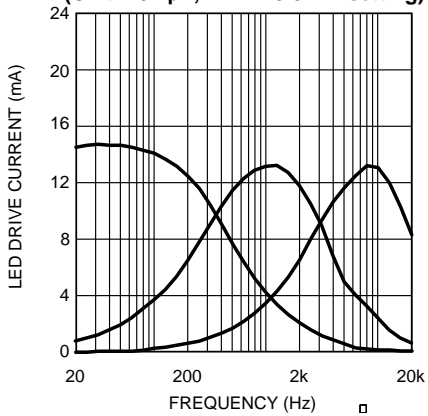

Figure 5.

**Audio Sync LED Frequency Response**  
(Left - lowband, Mid - midband, Right - highband)  
(Cfilt = 0.22 $\mu$ F, HPF = 3.5kHz setting)

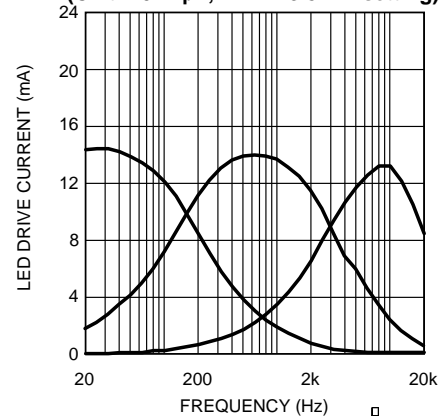

Figure 6.

**Audio Sync LED Frequency Response**  
(Left - lowband, Mid - midband, Right - highband)  
(Cfilt = 0.47 $\mu$ F, HPF = 3.5kHz setting)

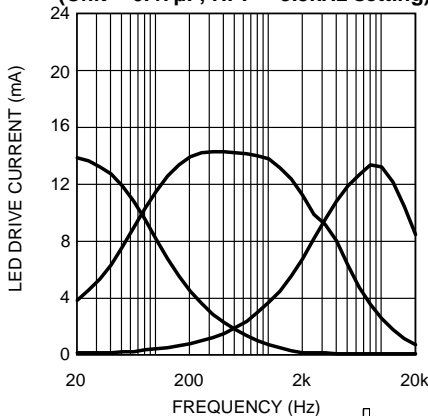

Figure 7.

**Audio Sync LED Frequency Response**  
(Left - lowband, Mid - midband, Right - highband)  
(Cfilt = 0.68 $\mu$ F, HPF = 3.5kHz setting)

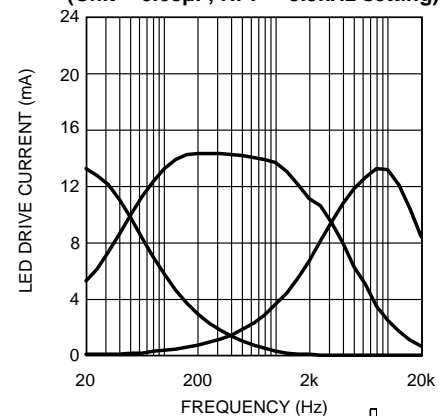

Figure 8.

(1) Audio input level set at 1V<sub>RMS</sub>. The input summing amplifier gain is set to 12dB.

Typical Performance Characteristics<sup>(1)</sup> (continued)

Audio Sync LED Frequency Response  
(Left - lowband, Mid - midband, Right - highband)  
(Cfilt = 1 $\mu$ F, HPF = 3.5kHz setting)

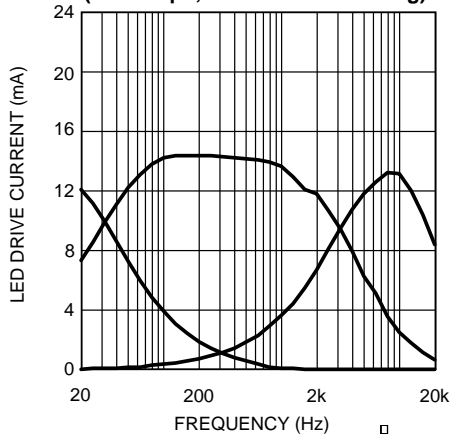

Figure 9.

Audio Sync LED Frequency Response  
(Left - lowband, Mid - midband, Right - highband)  
(Cfilt = 2.2 $\mu$ F, HPF = 3.5kHz setting)

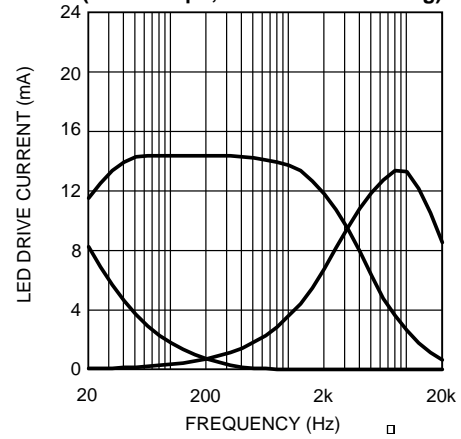

Figure 10.

Highpass Filter Frequency Response  
vs HPF\_F<1:0> setting  
(Top - 3.5kHz setting, Mid - 6.3kHz setting, Bot - 8.9kHz  
setting)

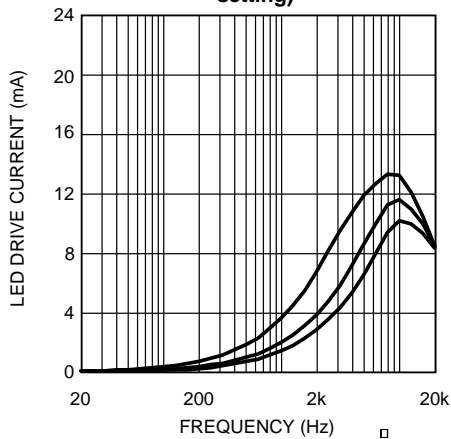

Figure 11.

Low Pass Filter Frequency Response vs Cfilt  
(From Left to Right: Cfilt ( $\mu$ F) = 2.2, 1.0, 0.68, 0.47, 0.22,  
0.1, 0.068, 0.047, No Cfilt)

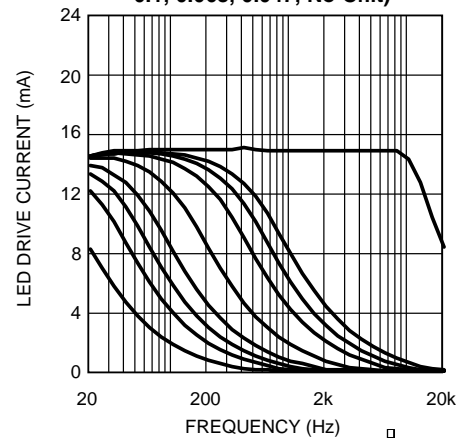
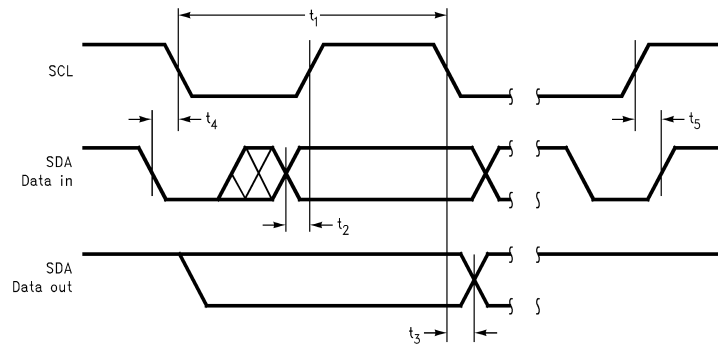
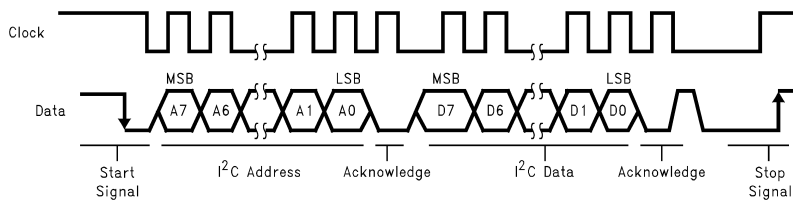

Figure 12.

**APPLICATION INFORMATION**



**Figure 13. I<sup>2</sup>C Timing Diagram**



**Figure 14. I<sup>2</sup>C Bus Format**

**Table 1. Color LED Driver Chip Address<sup>(1)</sup>**

	A7	A6	A5	A4	A3	A2	A1	A0
Chip Address	1	1	1	1	0	1	EC	0
ADR = 0	1	1	1	1	0	1	0	0
ADR = 1	1	1	1	1	0	1	1	0

(1) EC - externally configured by ADR pin

**Table 2. Color LED Driver Control Registers**

Register Name	D7	D6	D5	D4	D3	D2	D1	D0
Mode Select	0	0	0	MS4	MS3	MS2	MS1	MS0
Frequency Select	0	1	0	FS4	FS3	FS2	FS1	FS0
Pattern Select	0	1	1	PS4	PS3	PS2	PS1	PS0
Current Select	1	0	CS5	CS4	CS3	CS2	CS1	CS0
Gain Select	1	1	GS5	GS4	GS3	GS2	GS1	GS0

**Table 3. Mode Select Register**

Data Bit	Bit Name	Default Value	Condition	Function
MS0	I <sup>2</sup> C_SD	1	0	Enables device power up mode
			1	Enables device shutdown mode
MS1	I <sup>2</sup> C_RST	0	0	Enables device normal operation
			1	Enables device RESET, excluding the I <sup>2</sup> C register settings
MS2	RAND	1	0	Disables the audio synchronization randomizer
			1	Enables the audio synchronization randomizer
MS3	RSVD	0	0	RESERVED
			1	
MS4	RSVD	0	0	RESERVED
			1	

**Table 4. Frequency Select Register**

Data Bit	Bit Name	Default Value	Condition	Function	
FS0	PWM_F0	0	0	Programs the oscillation frequency of the PWM. PWM oscillation frequency is set as follows:	
			1	<b>PWM_F&lt;1:0&gt;</b>	<b>PWM Frequency</b>
FS1	PWM_F1	0	0	00	15kHz
				01	60Hz
			1	10	7Hz
				11	4Hz
FS2	RSVD	0	0	RESERVED	
			1		
FS3	HPF_F0	0	0	Programs the internal high pass filter cutoff frequency. High pass filter cutoff frequency is set as follows:	
			1		
FS4	HPF_F1	1	0	<b>HPF_F&lt;1:0&gt;</b>	High Pass Filter Cutoff Frequency
				1	00
			01		6.3kHz
			10		6.3kHz
				11	8.9kHz

**Table 5. Pattern Select Register**

Data Bit	Bit Name	Default Value	Condition	Function
PS0	I <sup>2</sup> C_SEL	0	0	Enables LED drivers to be controlled by audio synchronization
			1	Enables LED drivers to be controlled through I <sup>2</sup> C
PS1	I <sup>2</sup> C_LED1	0	0	Disables the LED1 driver, if I <sup>2</sup> C_SEL is set
			1	Enables the LED1 driver, if I <sup>2</sup> C_SEL is set
PS2	I <sup>2</sup> C_LED2	0	0	Disables the LED2 driver, if I <sup>2</sup> C_SEL is set
			1	Enables the LED2 driver, if I <sup>2</sup> C_SEL is set
PS3	I <sup>2</sup> C_LED3	0	0	Disables the LED3 driver, if I <sup>2</sup> C_SEL is set
			1	Enables the LED3 driver, if I <sup>2</sup> C_SEL is set
PS4	RSVD	0	0	RESERVED
			1	RESERVED

**Table 6. Current Select Register**

Data Bit	Bit Name	Default Value	Condition	Function	
CS0	ILED1_0	0	0	Programs the current drive of the LED1 driver. Current drive for LED1 is set as follows:	
			1	<b>ILED1&lt;1:0&gt;</b>	<b>Current Drive Setting</b>
CS1	ILED1_1	1	0	00	0.66X
				01	1X
			1	10	1.33X
				11	2X
CS2	ILED2_0	0	0	Programs the current drive of the LED2 driver. Current drive for LED2 is set as follows:	
			1	<b>ILED2&lt;1:0&gt;</b>	<b>Current Drive Setting</b>
CS3	ILED2_1	1	0	00	0.66X
				01	1X
			1	10	1.33X
				11	2X

**Table 6. Current Select Register (continued)**

Data Bit	Bit Name	Default Value	Condition	Function	
CS4	ILED3_0	0	0	Programs the current drive of the LED3 driver. Current drive for LED3 is set as follows:	
			1	<b>ILED3&lt;1:0&gt;</b>	<b>Current Drive Setting</b>
CS5	ILED3_1	1	0	00	0.66X
				01	1X
			1	10	1.33X
				11	2X

**Table 7. Gain Select Register**

Data Bit	Bit Name	Default Value	Condition	Function	
GSO	MGAIN0	0	0	Programs the gain response of the midband audio synchronized filter which drives the LED2 PWM color LED driver for the midband audio frequencies. Gain is set as follows:	
			1		
GS1	MGAIN1	1	0	<b>MGAIN&lt;2:0&gt;</b>	<b>Midband Filter Gain</b>
			1		
GS2	MGAIN2	0	1	000	minimum
				001	low
				010	medium
				011	high
				100	maximum
GS3	SGAIN0	0	0	Programs the audio gain of the input summing amplifier. Gain is set as follows:	
			1	<b>SGAIN&lt;2:0&gt;</b>	<b>Input Signal Gain</b>
GS4	SGAIN1	1	0	000	-11dB
			1	001	-6.5dB
GS5	SGAIN2	0	0	010	0dB
				011	3.5dB
			1	100	6dB
				101	10dB
				110	12dB

## I<sup>2</sup>C COMPATIBLE INTERFACE

The LM4970 uses a serial bus which conforms to the I<sup>2</sup>C protocol to control the chip's functions with two wires: clock (SCL) and data (SDA). The clock line is uni-directional. The data line is bi-directional (open-collector) with a pullup resistor (typically 10kΩ). The maximum clock frequency specified by the I<sup>2</sup>C standard is 400kHz. In this discussion, the master is the controlling microcontroller and the slave is the LM4970.

The I<sup>2</sup>C address for the LM4970 is determined using the ADR pin. The LM4970's two possible I<sup>2</sup>C chip addresses are of the form 111101X<sub>1</sub>0 (binary), where X<sub>1</sub> = 0, if ADR is logic low; and X<sub>1</sub> = 1, if ADR is logic high. If the I<sup>2</sup>C interface is used to address a number of chips in a system, the LM4970's chip address can be changed to avoid any possible address conflicts.

The bus format for the I<sup>2</sup>C interface is shown in [Figure 14](#). The data is latched in on the rising edge of the clock. The bus format diagram is broken up into six major sections:

The "start" signal is generated by lowering the data signal while the clock signal is high. The start signal will alert all devices attached to the I<sup>2</sup>C bus to check the incoming address against their own address.

The 8-bit chip address is sent next, most significant bit first. Each address bit must be stable while the clock level is high.

After the last bit of the address bit is sent, the master checks for the LM4970's acknowledge. The master releases the data line high (through a pullup resistor). Then the master sends a clock pulse. If the LM4970 has received the address correctly, then it holds the data line low during the clock pulse. If the data line is not low, then the master should send a "stop" signal (discussed later) and abort the transfer.

The 8 bits of data are sent next, most significant bit first. Each data bit should be valid while the clock level is stable high.

After the data byte is sent, the master must check for another acknowledge to see if the LM4970 received the data.

If the master has more data bytes to send to the LM4970, then the master can repeat the previous two steps until all data bytes have been sent.

The "stop" signal ends the transfer. To signal "stop", the data signal goes high while the clock signal is high. The data line should be held high when not in use.

## AUDIO SYNCHRONIZATION MODE

The LM4970 features an audio synchronization mode where each PWM color LED driver output is dependent on the audio input signal. The audio synchronization mode allows each LED output to react to the amplitude of the audio input signal, according to the LED output's assigned frequency band. Audio synchronization mode is activated by clearing the I2C\_SEL bit in the Pattern Select Register.

The audio synchronization filter separates the mixed audio signal into three frequency bands: lowband, midband, and highband. Each frequency band is assigned to a particular PWM LED output, with lowband controlling the duty cycle of the LED1 output, midband controlling the duty cycle of the LED2 output, and highband controlling the duty cycle of the LED3 output. This occurs whenever the audio synchronization randomizer is not turned on. The operation of the audio synchronization randomizer is explained in the [AUDIO SYNCHRONIZATION RANDOMIZER](#) section. The duty cycle of any given LED output is dependent upon the amplitude of the audio signal for its particular frequency band. An increase in the amplitude of the audio signal will increase the duty cycle of the PWM LED driver. LEDs driven with a higher duty cycle results in a brighter lighting effect.

The LM4970 has three single-ended analog audio inputs designated  $M_{IN}$ ,  $L_{IN}$ , and  $R_{IN}$ , where mono voice data is routed to  $M_{IN}$  and stereo MP3 or stereo FM radio data is routed to  $L_{IN}$  and  $R_{IN}$ . Audio signals coupled in from  $M_{IN}$ ,  $L_{IN}$ , and  $R_{IN}$  are mixed together by an audio input summing amplifier. The gain of the audio input summing amplifier is programmed by the SGAIN<2:0> bits of the Gain Select Register. Increasing the gain of the audio input summing amplifier will increase the intensity of the LEDs in audio synchronization mode.

The pole of the low pass filter band is set by the filter cap,  $C_{filt}$ , and an internal 4k $\Omega$  resistor. The pole of the high pass filter band is internally set by programming the HPF\_F<1:0> bits of the Frequency Select Register. The midband frequency band is a function of the lowband and highband poles. The gain response of the midband frequency band can be set by programming the MGAIN<2:0> bits of the Gain Select Register.

To minimize LED leakage between audio bands, care should be taken when selecting input gain, midband gain,  $C_{filt}$ , and LED current drive. There is a trade off between LED brightness and LED leakage in other audio bands. Leakage can be minimized by reducing LED current drive and input gain. Please refer to the frequency response graphs found in the [Typical Performance Characteristics](#) section as a guideline to minimize LED leakage.

## AUDIO SYNCHRONIZATION RANDOMIZER

The LM4970 features a randomizer block that randomizes the frequency band assigned to each PWM LED driver during audio synchronization operation. The randomizer is activated by setting the RAND bit in the Mode Select Register. Clearing the RAND bit will disable the randomizer. The randomizer can only be activated when the LM4970 is programmed to audio synchronization mode. The interval at which randomizer assigns a new frequency band is set to occur once every 3.2 seconds. The randomizer ensures that all the colored LEDs will light up over a long duration even if the audio input has a fixed frequency.

## I<sup>2</sup>C PATTERN MODE

The LM4970 features an I<sup>2</sup>C pattern mode for applications where direct control of the LED outputs is required. I<sup>2</sup>C pattern mode is activated by setting the I2C\_SEL bit in the Pattern Select Register. The LED1 output duty cycle can be programmed to 100% by setting the I2C\_LED1 bit in the Pattern Select Register. Clearing the I2C\_LED1 bit sets the LED1 output duty cycle to 0%. The LED2 output duty cycle can be programmed to 100% by setting the I2C\_LED2 bit in the Pattern Select Register. Clearing the I2C\_LED2 bit sets the LED2 output duty cycle to 0%. The LED3 output duty cycle can be programmed to 100% by setting the I2C\_LED3 bit in the Pattern Select Register. Clearing the I2C\_LED3 bit sets the LED3 output duty cycle to 0%. Color LEDs driven at 100% duty cycle are fully on, and driven at 0% duty cycle are fully off.

## PWM FREQUENCY

The PWM frequency of the color LED drivers is programmed through the PWM\_F<1:0> bits of the Frequency Select Register. The LM4970 features four different PWM frequency settings: 15kHz, 60Hz, 7Hz, and 4Hz. PWM frequency is analogous to the sampling rate of the audio input signal. A higher PWM frequency setting will result in a more accurate LED representation of the audio input signal in the audio synchronization mode. However, a PWM frequency that is set too high will decrease the ON time of the LED which will result in reduced LED intensity. A PWM frequency setting of 60Hz results in an optimal balance between LED accuracy and intensity.

## DRIVING RGB LED MODULES

The LM4970's PWM LED outputs can be used to drive individual color LEDs or RGB LED modules. When driving RGB LED modules in audio synchronization mode, the color and intensity of the RGB LED module will be dependent on the audio input signal. In I<sup>2</sup>C pattern mode, the RGB LED module can be set to any of seven distinct colors, based on the status of the I2C\_LED1, I2C\_LED2, and I2C\_LED3 bit settings.

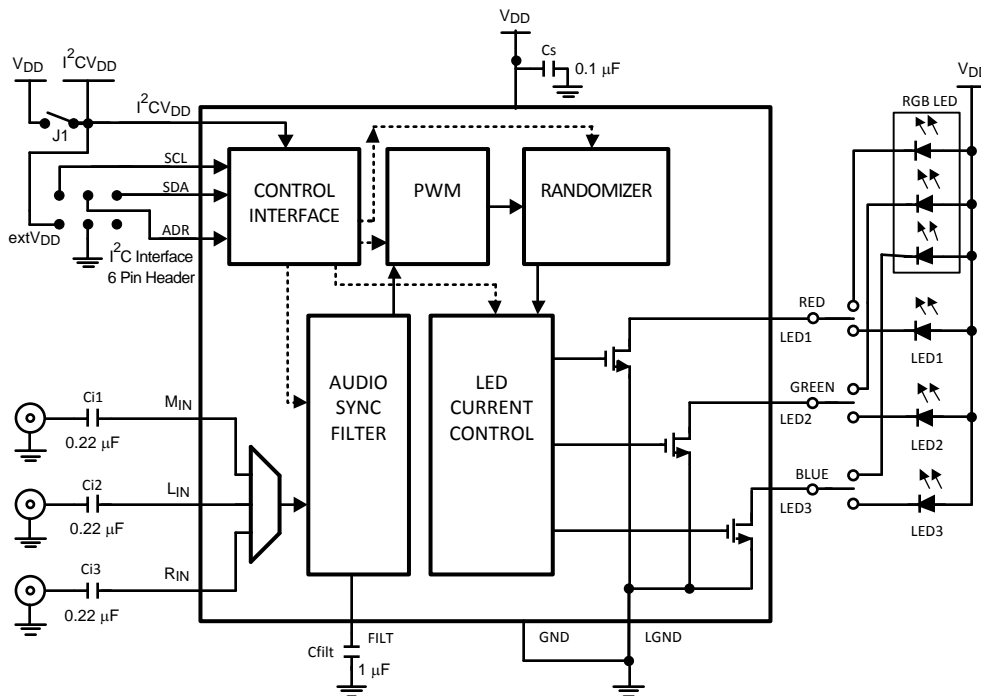

**Figure 15. Reference Design Board Schematic**

### Demonstration Board NHK PCB Layout

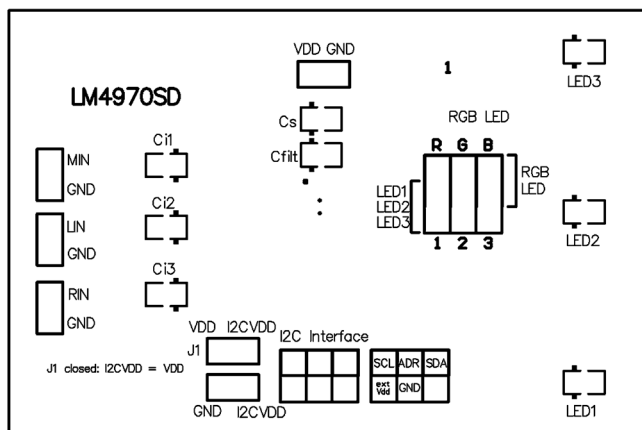

Figure 16. Recommended NHK PCB Layout: Top Silkscreen

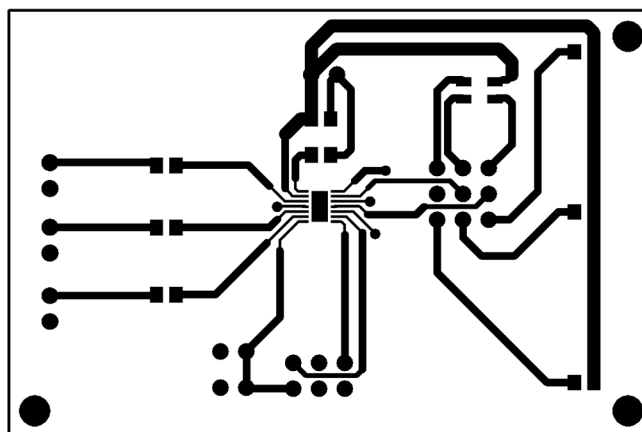

Figure 17. Recommended NHK PCB Layout: Top Layer

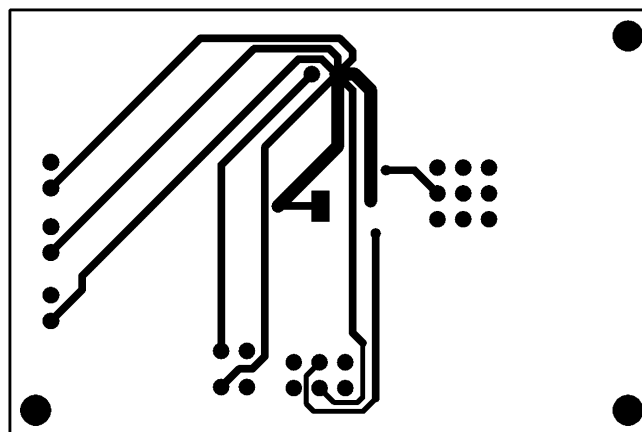

Figure 18. Recommended NHK PCB Layout: Bottom Layer

### Revision History

Rev	Date	Description
1.1	5/26/06	On Table 2 (pg 8), col D7 for Pattern Select, changed the '1' into '0'.
1.2	04/01/08	Added the last paragraph under the AUDIO SYNCHRONIZATION MODE.
D	05/03/13	Changed layout of National Data Sheet to TI format.

**PACKAGING INFORMATION**

Orderable Device	Status (1)	Package Type	Package Drawing	Pins	Package Qty	Eco Plan (2)	Lead/Ball Finish	MSL Peak Temp (3)	Op Temp (°C)	Device Marking (4/5)	Samples
LM4970SD/NOPB	ACTIVE	WSON	NHK	14	1000	Green (RoHS & no Sb/Br)	CU SN	Level-1-260C-UNLIM	-40 to 85	L4970	Samples

(1) The marketing status values are defined as follows:

**ACTIVE:** Product device recommended for new designs.

**LIFEBUY:** TI has announced that the device will be discontinued, and a lifetime-buy period is in effect.

**NRND:** Not recommended for new designs. Device is in production to support existing customers, but TI does not recommend using this part in a new design.

**PREVIEW:** Device has been announced but is not in production. Samples may or may not be available.

**OBSOLETE:** TI has discontinued the production of the device.

(2) Eco Plan - The planned eco-friendly classification: Pb-Free (RoHS), Pb-Free (RoHS Exempt), or Green (RoHS & no Sb/Br) - please check <http://www.ti.com/productcontent> for the latest availability information and additional product content details.

**TBD:** The Pb-Free/Green conversion plan has not been defined.

**Pb-Free (RoHS):** TI's terms "Lead-Free" or "Pb-Free" mean semiconductor products that are compatible with the current RoHS requirements for all 6 substances, including the requirement that lead not exceed 0.1% by weight in homogeneous materials. Where designed to be soldered at high temperatures, TI Pb-Free products are suitable for use in specified lead-free processes.

**Pb-Free (RoHS Exempt):** This component has a RoHS exemption for either 1) lead-based flip-chip solder bumps used between the die and package, or 2) lead-based die adhesive used between the die and leadframe. The component is otherwise considered Pb-Free (RoHS compatible) as defined above.

**Green (RoHS & no Sb/Br):** TI defines "Green" to mean Pb-Free (RoHS compatible), and free of Bromine (Br) and Antimony (Sb) based flame retardants (Br or Sb do not exceed 0.1% by weight in homogeneous material)

(3) MSL, Peak Temp. -- The Moisture Sensitivity Level rating according to the JEDEC industry standard classifications, and peak solder temperature.

(4) There may be additional marking, which relates to the logo, the lot trace code information, or the environmental category on the device.

(5) Multiple Device Markings will be inside parentheses. Only one Device Marking contained in parentheses and separated by a "~" will appear on a device. If a line is indented then it is a continuation of the previous line and the two combined represent the entire Device Marking for that device.

**Important Information and Disclaimer:** The information provided on this page represents TI's knowledge and belief as of the date that it is provided. TI bases its knowledge and belief on information provided by third parties, and makes no representation or warranty as to the accuracy of such information. Efforts are underway to better integrate information from third parties. TI has taken and continues to take reasonable steps to provide representative and accurate information but may not have conducted destructive testing or chemical analysis on incoming materials and chemicals. TI and TI suppliers consider certain information to be proprietary, and thus CAS numbers and other limited information may not be available for release.

In no event shall TI's liability arising out of such information exceed the total purchase price of the TI part(s) at issue in this document sold by TI to Customer on an annual basis.

## TAPE AND REEL INFORMATION



### QUADRANT ASSIGNMENTS FOR PIN 1 ORIENTATION IN TAPE

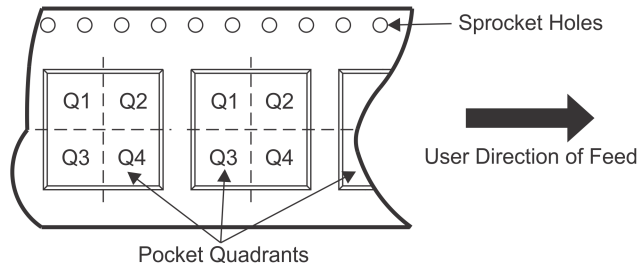

\*All dimensions are nominal

Device	Package Type	Package Drawing	Pins	SPQ	Reel Diameter (mm)	Reel Width W1 (mm)	A0 (mm)	B0 (mm)	K0 (mm)	P1 (mm)	W (mm)	Pin1 Quadrant
LM4970SD/NOPB	WSON	NHK	14	1000	178.0	12.4	3.3	4.3	1.0	8.0	12.0	Q1

**TAPE AND REEL BOX DIMENSIONS**



\*All dimensions are nominal

Device	Package Type	Package Drawing	Pins	SPQ	Length (mm)	Width (mm)	Height (mm)
LM4970SD/NOPB	WSON	NHK	14	1000	210.0	185.0	35.0



## IMPORTANT NOTICE

Texas Instruments Incorporated and its subsidiaries (TI) reserve the right to make corrections, enhancements, improvements and other changes to its semiconductor products and services per JESD46, latest issue, and to discontinue any product or service per JESD48, latest issue. Buyers should obtain the latest relevant information before placing orders and should verify that such information is current and complete. All semiconductor products (also referred to herein as "components") are sold subject to TI's terms and conditions of sale supplied at the time of order acknowledgment.

TI warrants performance of its components to the specifications applicable at the time of sale, in accordance with the warranty in TI's terms and conditions of sale of semiconductor products. Testing and other quality control techniques are used to the extent TI deems necessary to support this warranty. Except where mandated by applicable law, testing of all parameters of each component is not necessarily performed.

TI assumes no liability for applications assistance or the design of Buyers' products. Buyers are responsible for their products and applications using TI components. To minimize the risks associated with Buyers' products and applications, Buyers should provide adequate design and operating safeguards.

TI does not warrant or represent that any license, either express or implied, is granted under any patent right, copyright, mask work right, or other intellectual property right relating to any combination, machine, or process in which TI components or services are used. Information published by TI regarding third-party products or services does not constitute a license to use such products or services or a warranty or endorsement thereof. Use of such information may require a license from a third party under the patents or other intellectual property of the third party, or a license from TI under the patents or other intellectual property of TI.

Reproduction of significant portions of TI information in TI data books or data sheets is permissible only if reproduction is without alteration and is accompanied by all associated warranties, conditions, limitations, and notices. TI is not responsible or liable for such altered documentation. Information of third parties may be subject to additional restrictions.

Resale of TI components or services with statements different from or beyond the parameters stated by TI for that component or service voids all express and any implied warranties for the associated TI component or service and is an unfair and deceptive business practice. TI is not responsible or liable for any such statements.

Buyer acknowledges and agrees that it is solely responsible for compliance with all legal, regulatory and safety-related requirements concerning its products, and any use of TI components in its applications, notwithstanding any applications-related information or support that may be provided by TI. Buyer represents and agrees that it has all the necessary expertise to create and implement safeguards which anticipate dangerous consequences of failures, monitor failures and their consequences, lessen the likelihood of failures that might cause harm and take appropriate remedial actions. Buyer will fully indemnify TI and its representatives against any damages arising out of the use of any TI components in safety-critical applications.

In some cases, TI components may be promoted specifically to facilitate safety-related applications. With such components, TI's goal is to help enable customers to design and create their own end-product solutions that meet applicable functional safety standards and requirements. Nonetheless, such components are subject to these terms.

No TI components are authorized for use in FDA Class III (or similar life-critical medical equipment) unless authorized officers of the parties have executed a special agreement specifically governing such use.

Only those TI components which TI has specifically designated as military grade or "enhanced plastic" are designed and intended for use in military/aerospace applications or environments. Buyer acknowledges and agrees that any military or aerospace use of TI components which have **not** been so designated is solely at the Buyer's risk, and that Buyer is solely responsible for compliance with all legal and regulatory requirements in connection with such use.

TI has specifically designated certain components as meeting ISO/TS16949 requirements, mainly for automotive use. In any case of use of non-designated products, TI will not be responsible for any failure to meet ISO/TS16949.

### Products

Audio	<a href="http://www.ti.com/audio">www.ti.com/audio</a>
Amplifiers	<a href="http://amplifier.ti.com">amplifier.ti.com</a>
Data Converters	<a href="http://dataconverter.ti.com">dataconverter.ti.com</a>
DLP® Products	<a href="http://www.dlp.com">www.dlp.com</a>
DSP	<a href="http://dsp.ti.com">dsp.ti.com</a>
Clocks and Timers	<a href="http://www.ti.com/clocks">www.ti.com/clocks</a>
Interface	<a href="http://interface.ti.com">interface.ti.com</a>
Logic	<a href="http://logic.ti.com">logic.ti.com</a>
Power Mgmt	<a href="http://power.ti.com">power.ti.com</a>
Microcontrollers	<a href="http://microcontroller.ti.com">microcontroller.ti.com</a>
RFID	<a href="http://www.ti-rfid.com">www.ti-rfid.com</a>
OMAP Applications Processors	<a href="http://www.ti.com/omap">www.ti.com/omap</a>
Wireless Connectivity	<a href="http://www.ti.com/wirelessconnectivity">www.ti.com/wirelessconnectivity</a>

### Applications

Automotive and Transportation	<a href="http://www.ti.com/automotive">www.ti.com/automotive</a>
Communications and Telecom	<a href="http://www.ti.com/communications">www.ti.com/communications</a>
Computers and Peripherals	<a href="http://www.ti.com/computers">www.ti.com/computers</a>
Consumer Electronics	<a href="http://www.ti.com/consumer-apps">www.ti.com/consumer-apps</a>
Energy and Lighting	<a href="http://www.ti.com/energy">www.ti.com/energy</a>
Industrial	<a href="http://www.ti.com/industrial">www.ti.com/industrial</a>
Medical	<a href="http://www.ti.com/medical">www.ti.com/medical</a>
Security	<a href="http://www.ti.com/security">www.ti.com/security</a>
Space, Avionics and Defense	<a href="http://www.ti.com/space-avionics-defense">www.ti.com/space-avionics-defense</a>
Video and Imaging	<a href="http://www.ti.com/video">www.ti.com/video</a>

### TI E2E Community

[e2e.ti.com](http://e2e.ti.com)

## Looking for pricing, stock, or lifecycle information?

Click below to explore more details on WIN SOURCE:

 [View LM4970SDX/NOPB on WIN SOURCE](#)

 [Texas Instruments](#) Information

## Optimize Your Supply Chain with WIN SOURCE Solutions

-  Global Sourcing Solution
-  Obsolete Management
-  Cost Control Management
-  Shortage Management
-  Alternative Solution
-  Excess Inventory Management