



**THE DATASHEET OF
LT1792ACS8#PBF**



FEATURES

- **100% Tested Low Voltage Noise: $6\text{nV}/\sqrt{\text{Hz}}$ Max**
- **A Grade 100% Temperature Tested**
- Voltage Gain: 1.2 Million Min
- Offset Voltage Over Temp: $800\mu\text{V}$ Max
- Gain-Bandwidth Product: 5.6MHz Typ
- Guaranteed Specifications with $\pm 5\text{V}$ Supplies

APPLICATIONS

- Photocurrent Amplifiers
- Hydrophone Amplifiers
- High Sensitivity Piezoelectric Accelerometers
- Low Voltage and Current Noise Instrumentation Amplifier Front Ends
- Two and Three Op Amp Instrumentation Amplifiers
- Active Filters

DESCRIPTION

The LT[®]1792 achieves a new standard of excellence in noise performance for a JFET op amp. The $4.2\text{nV}/\sqrt{\text{Hz}}$ voltage noise combined with low current noise and picoampere bias currents make the LT1792 an ideal choice for amplifying low level signals from high impedance capacitive transducers.

The LT1792 is unconditionally stable for gains of 1 or more, even with load capacitances up to 1000pF . Other key features are $600\mu\text{V}$ V_{OS} and a voltage gain of over 4 million. Each individual amplifier is 100% tested for voltage noise, slew rate and gain bandwidth.

The design of the LT1792 has been optimized to achieve true precision performance with an industry standard pinout in the SO-8 package. Specifications are also provided for $\pm 5\text{V}$ supplies.

 LTC and LT are registered trademarks of Linear Technology Corporation.

TYPICAL APPLICATION

Low Noise Hydrophone Amplifier with DC Servo

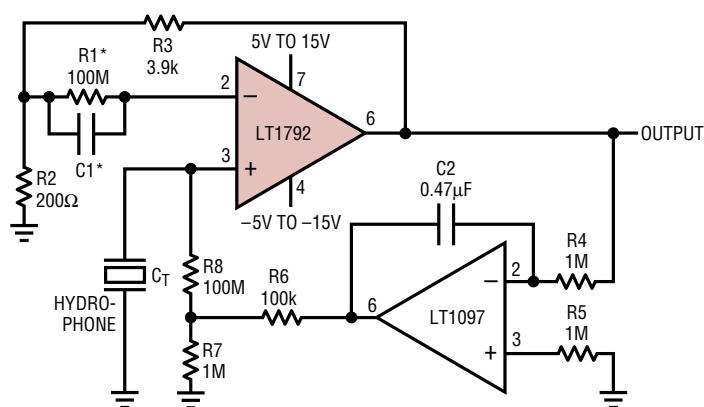

DC OUTPUT $\leq 2.5\text{mV}$ FOR $T_A < 70^\circ\text{C}$
 OUTPUT VOLTAGE NOISE = $128\text{nV}/\sqrt{\text{Hz}}$ AT 1kHz (GAIN = 20)
 $C_1 = C_T = 100\text{pF}$ TO 5000pF ; $R_4C_2 > R_8C_T$; *OPTIONAL

1792 TA01

1kHz Input Noise Voltage Distribution

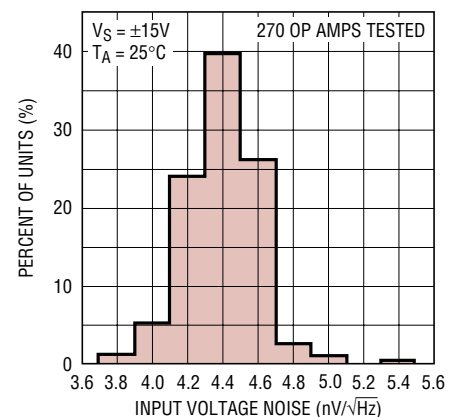

1792 TA02

ABSOLUTE MAXIMUM RATINGS (Note 1)

Supply Voltage	±20V	Specified Temperature Range	
Differential Input Voltage	±40V	Commercial (Note 8)	–40°C to 85°C
Input Voltage (Equal to Supply Voltage)	±20V	Industrial	–40°C to 85°C
Output Short-Circuit Duration	Indefinite	Storage Temperature Range	–65°C to 150°C
Operating Temperature Range	–40°C to 85°C	Lead Temperature (Soldering, 10 sec)	300°C

PACKAGE/ORDER INFORMATION

<p>N8 PACKAGE 8-LEAD PDIP</p> <p>$T_{JMAX} = 140^{\circ}C, \theta_{JA} = 130^{\circ}C/W$</p>	ORDER PART NUMBER	<p>S8 PACKAGE 8-LEAD PLASTIC SO</p> <p>$T_{JMAX} = 160^{\circ}C, \theta_{JA} = 190^{\circ}C/W$</p>	ORDER PART NUMBER
	LT1792ACN8 LT1792CN8 LT1792AIN8 LT1792IN8		LT1792ACS8 LT1792CS8 LT1792AIS8 LT1792IS8
		S8 PART MARKING	
		1792A 1792AI 1792 1792I	

Consult factory for Military grade parts.

ELECTRICAL CHARACTERISTICS $T_A = 25^{\circ}C, V_S = \pm 15V, V_{CM} = 0V$, unless otherwise noted. (Note 9)

SYMBOL	PARAMETER	CONDITIONS (Note 2)	LT1792AC/LT1792AI			LT1792C/LT1792I			UNITS
			MIN	TYP	MAX	MIN	TYP	MAX	
V_{OS}	Input Offset Voltage	$V_S = \pm 5V$		0.2	0.6		0.2	0.8	mV
				0.4	1.0		0.4	1.3	mV
I_{OS}	Input Offset Current	Warmed Up (Note 3)		100	400		100	400	pA
I_B	Input Bias Current	Warmed Up (Note 3)		300	800		300	800	pA
e_n	Input Noise Voltage	0.1Hz to 10Hz		2.4			2.4		μV_{p-p}
	Input Noise Voltage Density	$f_0 = 10Hz$		8.3			8.3		nV/\sqrt{Hz}
		$f_0 = 1000Hz$		4.2	6.0		4.2	6.0	nV/\sqrt{Hz}
i_n	Input Noise Current Density	$f_0 = 10Hz, f_0 = 1000Hz$ (Note 4)		10			10		fA/\sqrt{Hz}
R_{IN}	Input Resistance			10^{11}			10^{11}		Ω
	Differential Mode	$V_{CM} = -10V$ to 8V		10^{11}			10^{11}		Ω
	Common Mode	$V_{CM} = 8V$ to 11V		10^{10}			10^{10}		Ω
C_{IN}	Input Capacitance	$V_S = \pm 5V$		14			14		pF
				27			27		pF
V_{CM}	Input Voltage Range (Note 5)		13.0	13.5		13.0	13.5		V
			-10.5	-11.0		-10.5	-11.0		V
CMRR	Common Mode Rejection Ratio	$V_{CM} = -10V$ to 13V	85	105		82	100		dB
PSRR	Power Supply Rejection Ratio	$V_S = \pm 4.5V$ to $\pm 20V$	88	105		83	98		dB

ELECTRICAL CHARACTERISTICS $T_A = 25^\circ\text{C}$, $V_S = \pm 15\text{V}$, $V_{CM} = 0\text{V}$, unless otherwise noted.

SYMBOL	PARAMETER	CONDITIONS	LT1792AC/LT1792AI			LT1792C/LT1792I			UNITS
			MIN	TYP	MAX	MIN	TYP	MAX	
A_{VOL}	Large-Signal Voltage Gain	$V_O = \pm 12\text{V}$, $R_L = 10\text{k}$	1200	4800		1000	4500		V/mV
		$V_O = \pm 10\text{V}$, $R_L = 1\text{k}$	600	4000		500	3000		V/mV
V_{OUT}	Output Voltage Swing	$R_L = 10\text{k}$	± 13.0	± 13.2		± 13.0	± 13.2		V
		$R_L = 1\text{k}$	± 12.0	± 12.3		± 12.0	± 12.3		V
SR	Slew Rate	$R_L \geq 2\text{k}$ (Note 7)	2.3	3.4		2.3	3.4		V/ μs
GBW	Gain-Bandwidth Product	$f_0 = 100\text{kHz}$	4.0	5.6		4.0	5.6		MHz
I_S	Supply Current	$V_S = \pm 5\text{V}$		4.2	5.20		4.2	5.20	mA
				4.2	5.15		4.2	5.15	mA
	Offset Voltage Adjustment Range	R_{POT} (to V_{EE}) = 10k		10			10		mV

The ● denotes specifications which apply over the temperature range $0^\circ\text{C} \leq T_A \leq 70^\circ\text{C}$. $V_S = \pm 15\text{V}$, $V_{CM} = 0\text{V}$, unless otherwise noted. (Note 9)

SYMBOL	PARAMETER	CONDITIONS (Note 2)		LT1792AC			LT1792C			UNITS
				MIN	TYP	MAX	MIN	TYP	MAX	
V_{OS}	Input Offset Voltage	$V_S = \pm 5\text{V}$	●		0.4	0.8		0.8	2.7	mV
			●		0.6	1.2		1.2	3.2	mV
$\frac{\Delta V_{OS}}{\Delta \text{Temp}}$	Average Input Offset Voltage Drift	(Note 6)	●		4	10		7	40	$\mu\text{V}/^\circ\text{C}$
I_{OS}	Input Offset Current		●		180	500		180	500	pA
I_B	Input Bias Current		●		500	1800		500	1800	pA
V_{CM}	Input Voltage Range		●	12.9	13.4		12.9	13.4		V
			●	-10.0	-10.8		-10.0	-10.8		V
CMRR	Common Mode Rejection Ratio	$V_{CM} = -10\text{V}$ to 12.9V	●	81	104		79	99		dB
PSRR	Power Supply Rejection Ratio	$V_S = \pm 4.5\text{V}$ to $\pm 20\text{V}$	●	85	99		81	97		dB
A_{VOL}	Large-Signal Voltage Gain	$V_O = \pm 12\text{V}$, $R_L = 10\text{k}$	●	900	3600		800	3400		V/mV
			●	500	2600		400	2400		V/mV
V_{OUT}	Output Voltage Swing	$R_L = 10\text{k}$	●	± 12.9	± 13.2		± 12.9	± 13.2		V
			●	± 11.9	± 12.15		± 11.9	± 12.15		V
SR	Slew Rate	$R_L \geq 2\text{k}$ (Note 7)	●	2.1	3.1		2.1	3.1		V/ μs
GBW	Gain-Bandwidth Product	$f_0 = 100\text{kHz}$	●	3.2	4.5		3.2	4.5		MHz
I_S	Supply Current	$V_S = \pm 5\text{V}$	●		4.2	5.30		4.2	5.30	mA
			●		4.2	5.25		4.2	5.25	mA

ELECTRICAL CHARACTERISTICS The ● denotes specifications which apply over the temperature range $-40^{\circ}\text{C} \leq T_A \leq 85^{\circ}\text{C}$. $V_S = \pm 15\text{V}$, $V_{CM} = 0\text{V}$, unless otherwise noted. (Notes 8, 9)

SYMBOL	PARAMETER	CONDITIONS (Note 2)		LT1792AC/LT1792AI			LT1792C/LT1792I			UNITS
				MIN	TYP	MAX	MIN	TYP	MAX	
V_{OS}	Input Offset Voltage	$V_S = \pm 5\text{V}$	●	0.5	1.0		1.2	3.7	mV	
			●	0.8	1.4		1.5	4.2	mV	
$\frac{\Delta V_{OS}}{\Delta \text{Temp}}$	Average Input Offset Voltage Drift	(Note 6)	●	4	10		7	40	$\mu\text{V}/^{\circ}\text{C}$	
I_{OS}	Input Offset Current		●	300	800		300	800	pA	
I_B	Input Bias Current		●	1200	4000		1200	4000	pA	
V_{CM}	Input Voltage Range		●	12.6	13.0		12.6	13.0	V	
			●	-10.0	-10.5		-10.0	-10.5	V	
CMRR	Common Mode Rejection Ratio	$V_{CM} = -10\text{V}$ to 12.6V	●	80	103		78	98	dB	
PSRR	Power Supply Rejection Ratio	$V_S = \pm 4.5\text{V}$ to $\pm 20\text{V}$	●	83	98		79	96	dB	
A_{VOL}	Large-Signal Voltage Gain	$V_O = \pm 12\text{V}$, $R_L = 10\text{k}$ $V_O = \pm 10\text{V}$, $R_L = 1\text{k}$	●	850	3300		750	3000	V/mV	
			●	400	2200		300	2000	V/mV	
V_{OUT}	Output Voltage Swing	$R_L = 10\text{k}$ $R_L = 1\text{k}$	●	± 12.8	± 13.1		± 12.8	± 13.1	V	
			●	± 11.8	± 12.1		± 11.8	± 12.1	V	
SR	Slew Rate	$R_L \geq 2\text{k}$	●	2.0	3.0		2.0	3.0	$\text{V}/\mu\text{s}$	
GBW	Gain-Bandwidth Product	$f_0 = 100\text{kHz}$	●	2.9	4.3		2.9	4.3	MHz	
I_S	Supply Current	$V_S = \pm 5\text{V}$	●	4.2	5.40		4.2	5.40	mA	
			●	4.2	5.35		4.2	5.35	mA	

Note 1: Absolute Maximum Ratings are those values beyond which the life of a device may be impaired.

Note 2: Typical parameters are defined as the 60% yield of parameter distributions of individual amplifiers.

Note 3: Warmed-up I_B and I_{OS} readings are extrapolated to a chip temperature of 32°C from 25°C measurements and 32°C characterization data.

Note 4: Current noise is calculated from the formula:

$$i_n = (2qI_B)^{1/2}$$

where $q = 1.6 \cdot 10^{-19}$ coulomb. The noise of source resistors up to 200M swamps the contribution of current noise.

Note 5: Input voltage range functionality is assured by testing offset voltage at the input voltage range limits to a maximum of 2.3mV (A grade), to 2.8mV (C grade).

Note 6: This parameter is not 100% tested.

Note 7: Slew rate is measured in $A_V = -1$; input signal is $\pm 7.5\text{V}$, output measured at $\pm 2.5\text{V}$.

Note 8: The LT1792AC and LT1792C are guaranteed to meet specified performance from 0°C to 70°C and are designed, characterized and expected to meet these extended temperature limits, but are not tested at -40°C and 85°C . The LT1792I is guaranteed to meet the extended temperature limits. The LT1792AC and LT1792AI grade are 100% temperature tested for the specified temperature range.

Note 9: The LT1792 is measured in an automated tester in less than one second after application of power. Depending on the package used, power dissipation, heat sinking, and air flow conditions, the fully warmed-up chip temperature can be 10°C to 50°C higher than the ambient temperature.

TYPICAL PERFORMANCE CHARACTERISTICS

0.1Hz to 10Hz Voltage Noise

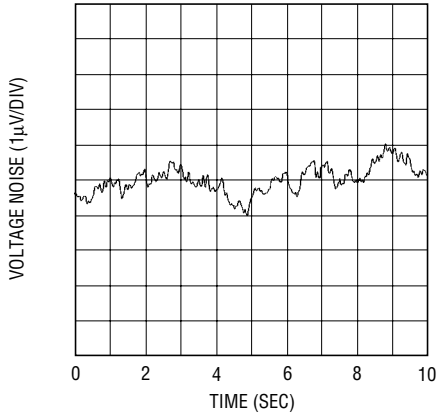

1792 G01

Voltage Noise vs Frequency

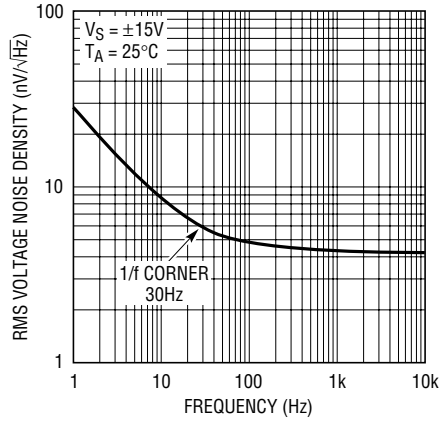

1792 G02

Voltage Noise vs Chip Temperature

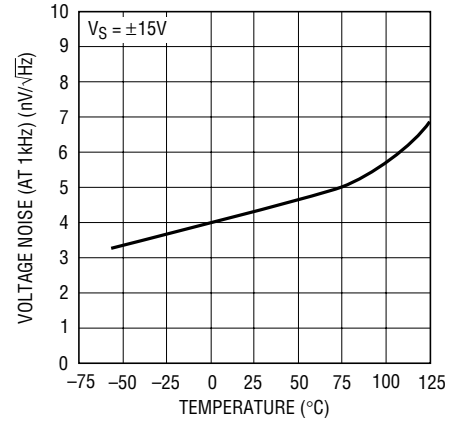

1792 G03

Input Bias and Offset Current Over the Common Mode Range

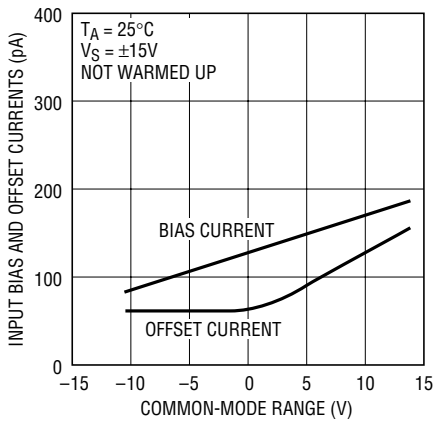

1792 G22

Input Bias and Offset Current vs Chip Temperature

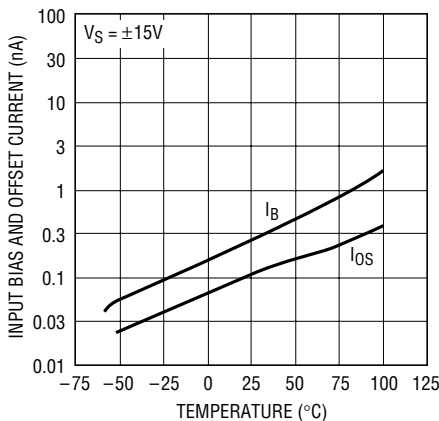

1792 G04

Common Mode Limit vs Temperature

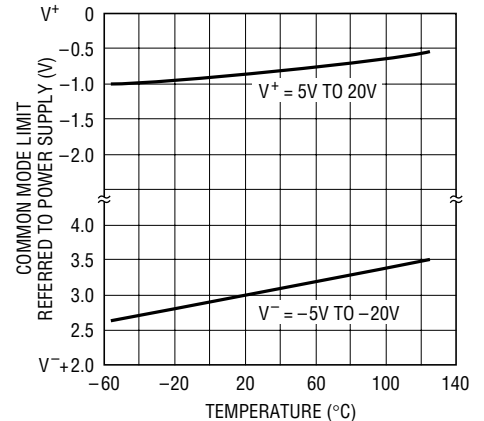

1792 G05

Common Mode Rejection Ratio vs Frequency

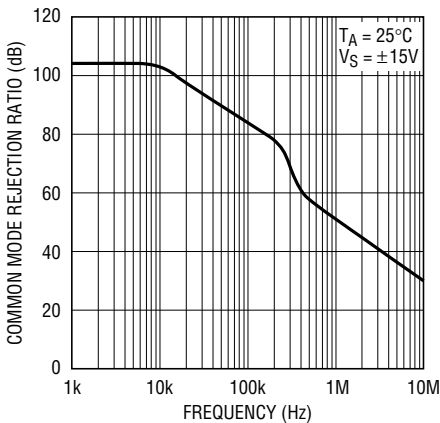

1792 G06

Power Supply Rejection Ratio vs Frequency

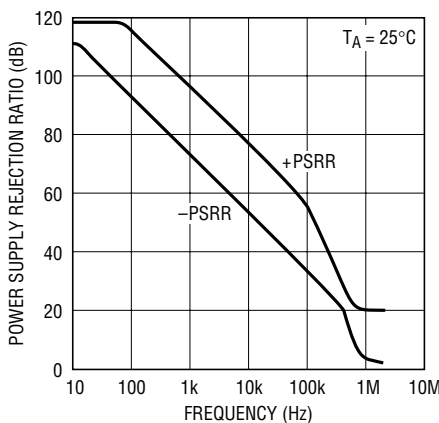

1792 G07

Voltage Gain vs Frequency

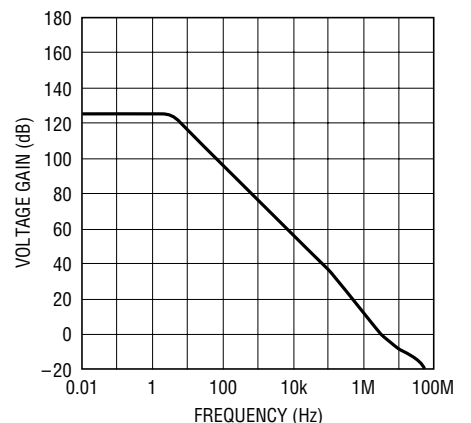

1792 G08

TYPICAL PERFORMANCE CHARACTERISTICS

Gain and Phase Shift vs Frequency

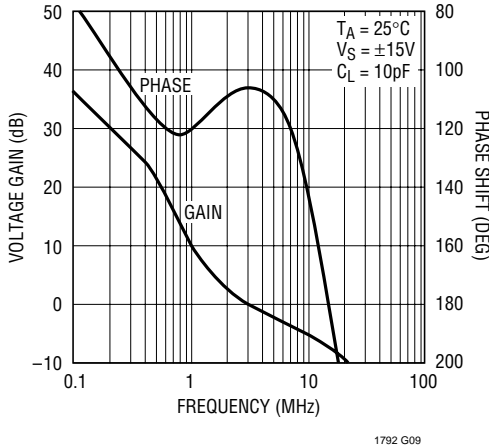

1792 G09

Small-Signal Transient Response

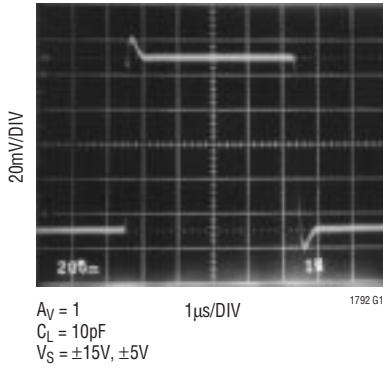

1792 G10

Large-Signal Transient Response

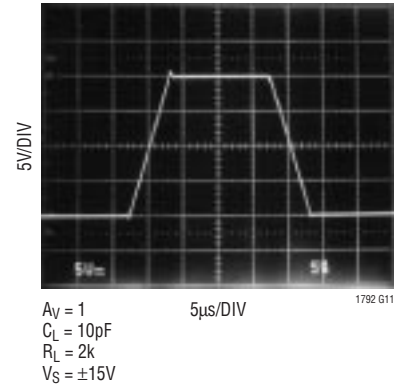

1792 G11

Output Voltage Swing vs Load Current

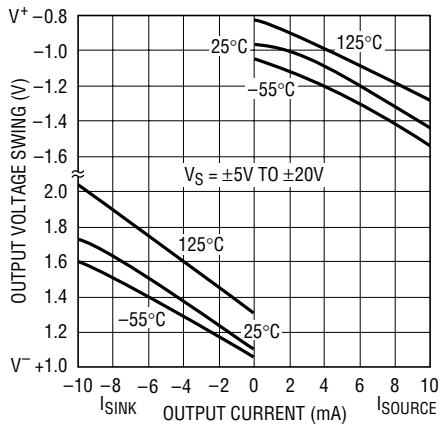

1792 G12

Capacitive Load Handling

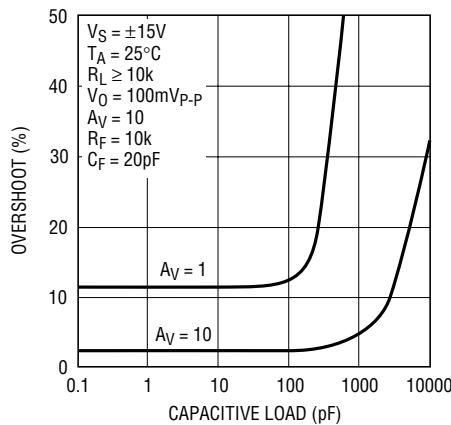

1792 G13

Slew Rate and Gain-Bandwidth Product vs Temperature

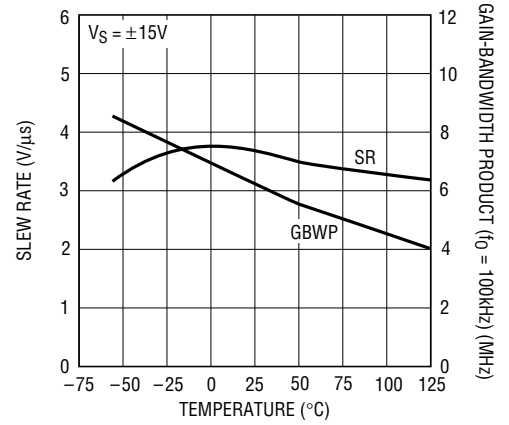

1792 G14

Warm-Up Drift

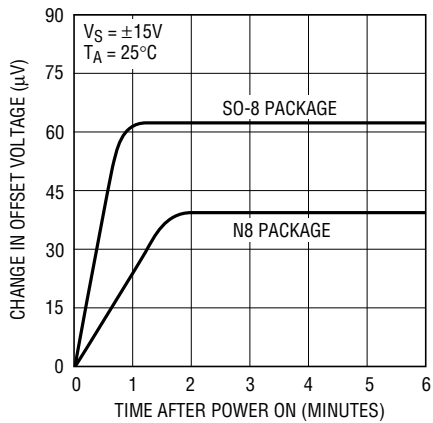

1792 G15

THD and Noise vs Frequency for Noninverting Gain

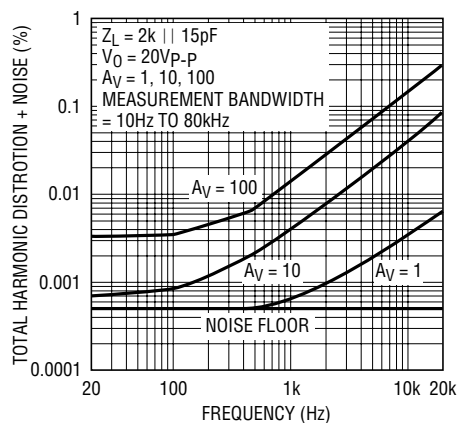

1792 G16

THD and Noise vs Frequency for Inverting Gain

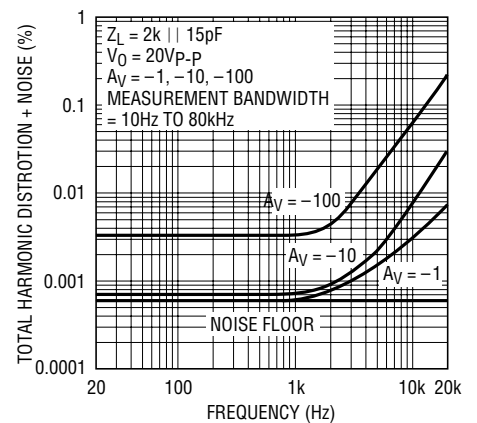

1792 G17

TYPICAL PERFORMANCE CHARACTERISTICS

THD and Noise vs Output Amplitude for Noninverting Gain

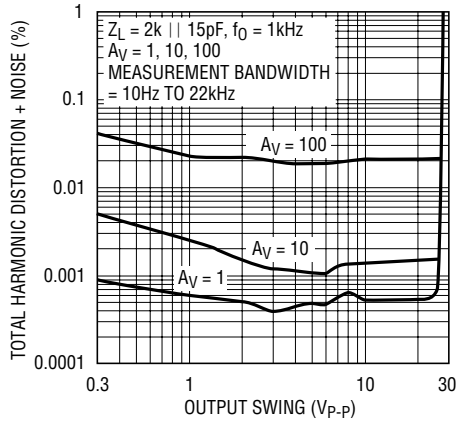

1792 G18

THD and Noise vs Output Amplitude for Inverting Gain

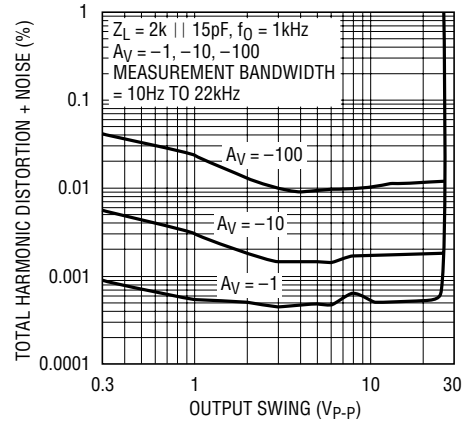

1792 G19

Short-Circuit Output Current vs Temperature

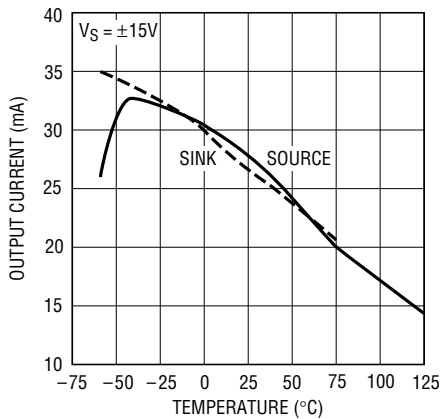

1792 G20

Supply Current vs Temperature

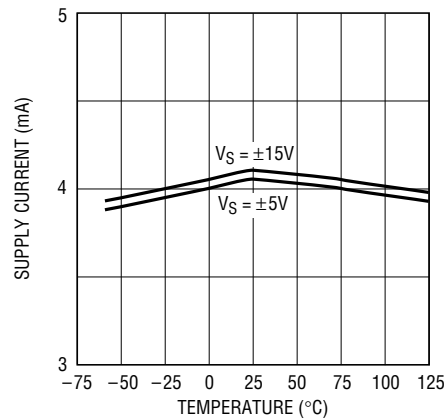

1792 G21

APPLICATIONS INFORMATION

The LT1792 may be inserted directly into OPA124, AD743, AD745, AD645, AD544 and AD820 sockets with improved noise performance. Offset nulling will be compatible with these devices with the wiper of the potentiometer tied to the negative supply (Figure 1a). No appreciable change in offset voltage drift with temperature will occur when the device is nulled with a potentiometer ranging from 10k to 200k. Finer adjustments can be made with resistors in series with the potentiometer (Figure 1b).

Being a low voltage noise JFET op amp, the LT1792 can replace many bipolar op amps that are used in amplifying low level signals from high impedance transducers. The

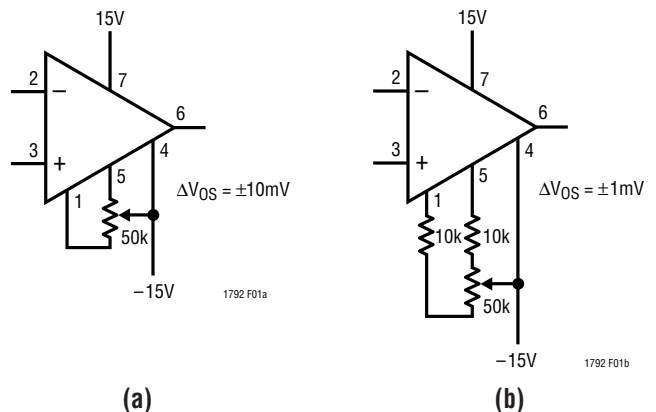

Figure 1

APPLICATIONS INFORMATION

best bipolar op amps, with higher current noise, will eventually lose out to the LT1792 when transducer impedance increases. The low voltage noise of the LT1792 allows it to surpass most single JFET op amps available. For the best performance versus area available anywhere, the LT1792 is offered in the SO-8 surface mount package with no degradation in performance.

The low voltage and current noise offered by the LT1792 makes it useful in a wide range of applications, especially where high impedance, capacitive transducers are used such as hydrophones, precision accelerometers and photo diodes. The total output noise in such a system is the gain times the RMS sum of the op amp input referred voltage noise, the thermal noise of the transducer, and the op amp bias current noise times the transducer impedance. Figure 2 shows total input voltage noise versus source resistance. In a low source resistance (<5k) application the op amp voltage noise will dominate the total noise. This means the LT1792 will beat out any JFET op amp, only the lowest noise bipolar op amps have the edge at low source resistances. As the source resistance increases from 5k to 50k, the LT1792 will match the best bipolar op amps for noise performance, since the thermal noise of the transducer (4kTR) begins to dominate the total noise. A further increase in source resistance, above 50k, is where the op amp's current noise component (2qI_B R_{TRANS}) will eventually dominate the total noise. At these high source resistances, the LT1792 will out perform the lowest noise bipolar op amp due to the inherently low

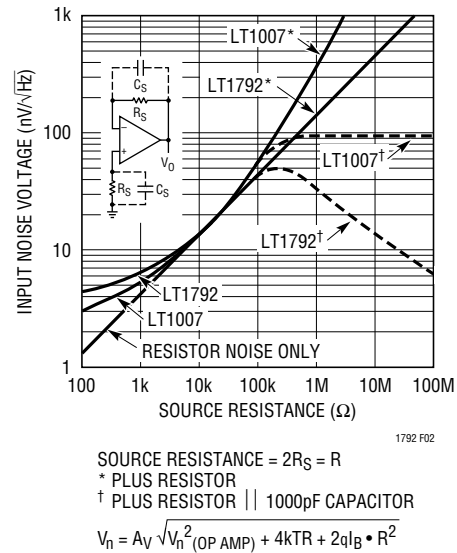

Figure 2. Comparison of LT1792 and LT1007 Total Output 1kHz Voltage Noise Versus Source Resistance

current noise of FET input op amps. Clearly, the LT1792 will extend the range of high impedance transducers that can be used for high signal-to-noise ratios. This makes the LT1792 the best choice for high impedance, capacitive transducers.

The high input impedance JFET front end makes the LT1792 suitable in applications where very high charge sensitivity is required. Figure 3 illustrates the LT1792 in its inverting and noninverting modes of operation. A charge amplifier is shown in the inverting mode example; here the gain depends on the principal of charge conservation at

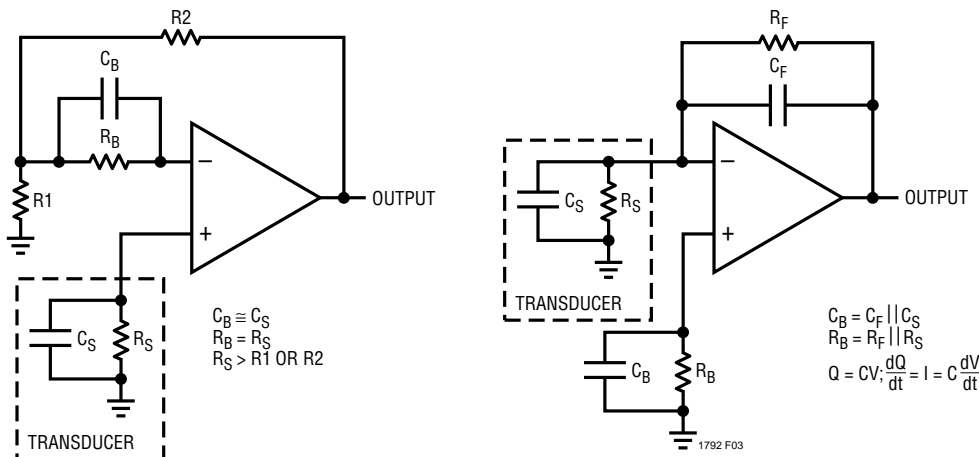

Figure 3. Noninverting and Inverting Gain Configurations

APPLICATIONS INFORMATION

the input of the LT1792. The charge across the transducer capacitance, C_S , is transferred to the feedback capacitor C_F , resulting in a change in voltage, dV , equal to dQ/C_F . The gain therefore is C_F/C_S . For unity gain, the C_F should equal the transducer capacitance plus the input capacitance of the LT1792 and R_F should equal R_S . In the noninverting mode example, the transducer current is converted to a change in voltage by the transducer capacitance; this voltage is then buffered by the LT1792 with a gain of $1 + R1/R2$. A DC path is provided by R_S , which is either the transducer impedance or an external resistor. Since R_S is usually several orders of magnitude greater than the parallel combination of $R1$ and $R2$, R_B is added to balance the DC offset caused by the noninverting input bias current and R_S . The input bias currents, although small at room temperature, can create significant errors at higher temperature, especially with transducer resistances of up to 100M or more. The optimum value for R_S is determined by equating the thermal noise ($4kTR_S$) to the current noise times R_S , $[(2qI_B) \cdot R_S]$, resulting in $R_B = 2V_T/I_B$ ($V_T = 26\text{mV}$ at 25°C). A parallel capacitor, C_B , is used to cancel the phase shift caused by the op amp input capacitance and R_B .

Reduced Power Supply Operation

The LT1792 can be operated from $\pm 5\text{V}$ supplies for lower power dissipation resulting in lower I_B and noise at the

expense of reduced dynamic range. To illustrate this benefit, let's take the following example:

An LT1792CS8 operates at an ambient temperature of 25°C with $\pm 15\text{V}$ supplies, dissipating 159mW of power (typical supply current = 5.3mA). The SO-8 package has a θ_{JA} of 190°C/W , which results in a die temperature increase of 30.2°C or a room temperature die operating temperature of 55.2°C . At $\pm 5\text{V}$ supplies, the die temperature increases by only one third of the previous amount or 10.1°C resulting in a typical die operating temperature of only 35.1°C . A 20 degree reduction of die temperature is achieved at the expense of a 20V reduction in dynamic range.

To take full advantage of a wide input common mode range, the LT1792 was designed to eliminate phase reversal. Referring to the photographs shown in Figure 4, the LT1792 is shown operating in the follower mode ($A_V = 1$) at $\pm 5\text{V}$ supplies with the input swinging $\pm 5.2\text{V}$. The output of the LT1792 clips cleanly and recovers with no phase reversal. This has the benefit of preventing lock-up in servo systems and minimizing distortion components.

High Speed Operation

The low noise performance of the LT1792 was achieved by making the input JFET differential pair large to maximize the first stage gain. Increasing the JFET geometry

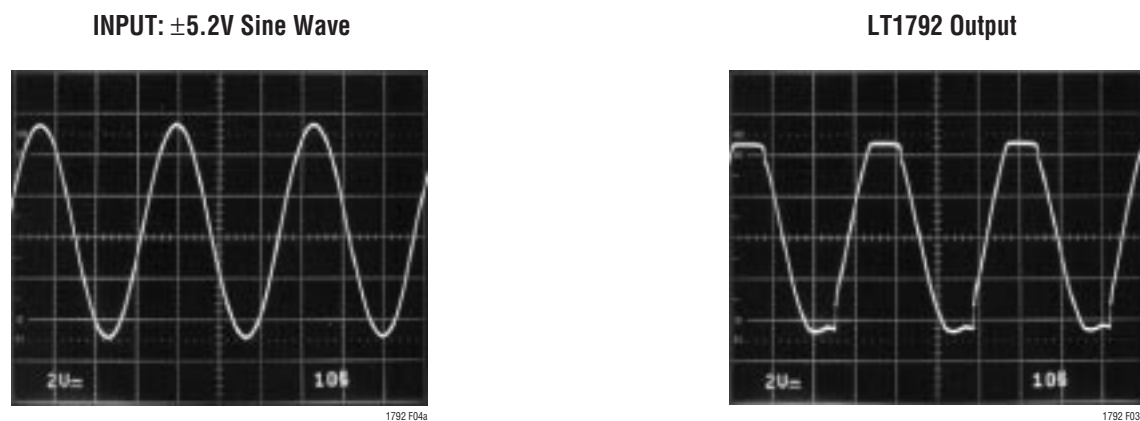
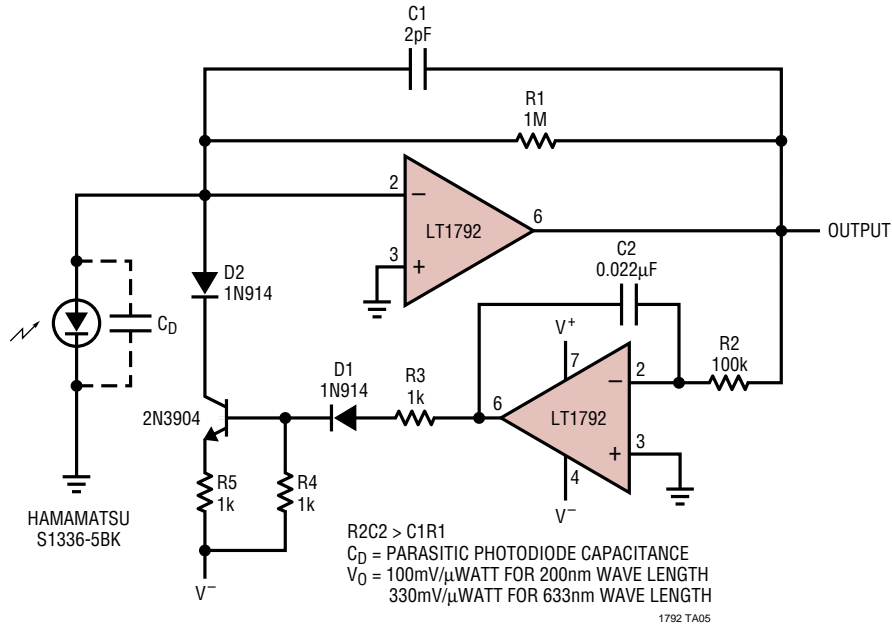

Figure 4. Voltage Follower with Input Exceeding the Common Mode Range ($V_S = \pm 5\text{V}$)

TYPICAL APPLICATIONS

Low Noise Light Sensor with DC Servo



Paralleling Amplifiers to Reduce Voltage Noise

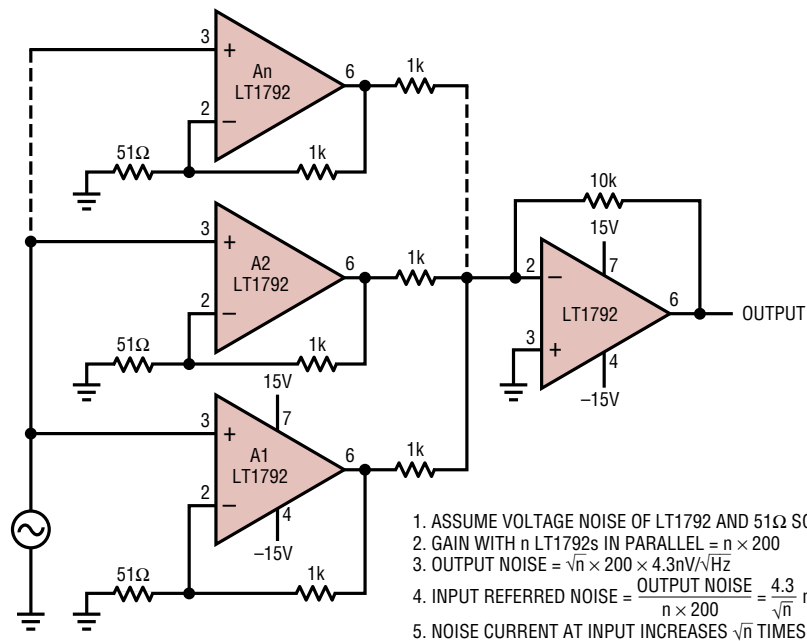

TYPICAL APPLICATIONS

Light Balance Detection Circuit

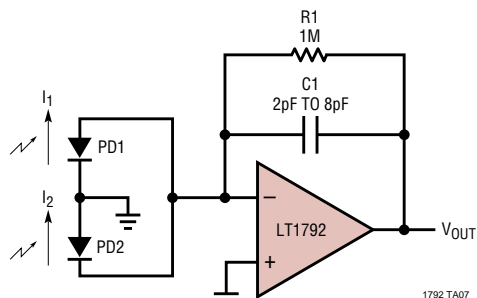

$V_{OUT} = 1M \times (I_1 - I_2)$
 PD1 PD2 = HAMAMATSU S1336-5BK
 WHEN EQUAL LIGHT ENTERS PHOTODIODES, $V_{OUT} < 3mV$.

Unity-Gain Buffer with Extended Load Capacitance Drive Capability

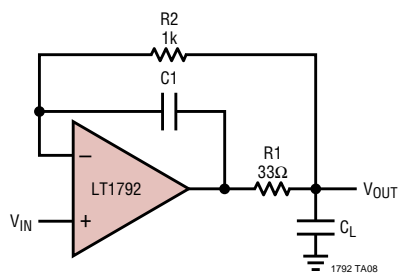

$C1 = C_L \leq 0.1\mu F$
 OUTPUT SHORT-CIRCUIT CURRENT
 (~ 30mA) WILL LIMIT THE RATE AT WHICH THE
 VOLTAGE CAN CHANGE ACROSS LARGE CAPACITORS
 $I = C \left(\frac{dV}{dt} \right)$

PACKAGE DESCRIPTION

Dimensions in inches (millimeters) unless otherwise noted.

N8 Package
8-Lead PDIP (Narrow 0.300)
 (LTC DWG # 05-08-1510)

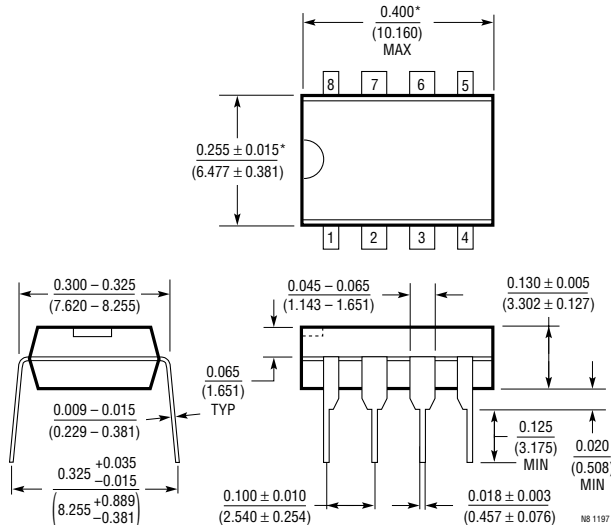

*THESE DIMENSIONS DO NOT INCLUDE MOLD FLASH OR PROTRUSIONS.
 MOLD FLASH OR PROTRUSIONS SHALL NOT EXCEED 0.010 INCH (0.254mm)

S8 Package
8-Lead Plastic Small Outline (Narrow 0.150)
 (LTC DWG # 05-08-1610)

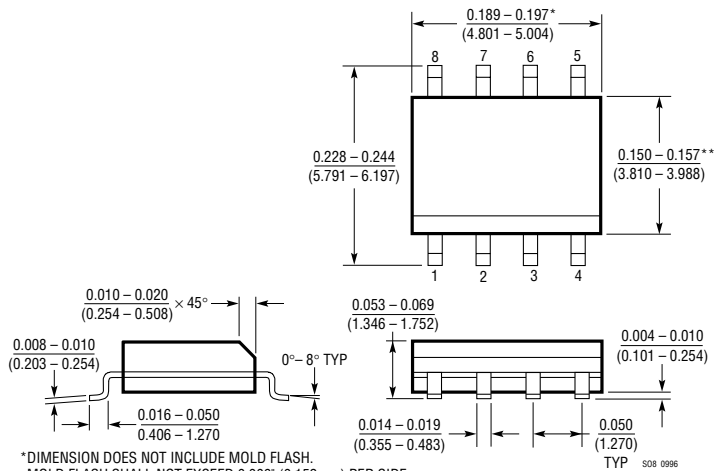

*DIMENSION DOES NOT INCLUDE MOLD FLASH.
 MOLD FLASH SHALL NOT EXCEED 0.006" (0.152mm) PER SIDE
 **DIMENSION DOES NOT INCLUDE INTERLEAD FLASH.
 INTERLEAD FLASH SHALL NOT EXCEED 0.010" (0.254mm) PER SIDE

RELATED PARTS

PART NUMBER	DESCRIPTION	COMMENTS
LT1113	Low Noise Dual JFET Op Amp	Dual Version of LT1792, $V_{NOISE} = 4.5nV/\sqrt{Hz}$
LT1169	Low Noise Dual JFET Op Amp	Dual Version of LT1793, $I_B = 10pA$, $V_{NOISE} = 6nV/\sqrt{Hz}$
LT1793	Low Noise Single Op Amp	Lower I_B Version of LT1792, $I_B = 10pA$, $V_{NOISE} = 6nV/\sqrt{Hz}$

Looking for pricing, stock, or lifecycle information?

Click below to explore more details on WIN SOURCE:

 [View LT1792ACS8#PBF on WIN SOURCE](#)

 [Linear Technology](#) Information

Optimize Your Supply Chain with WIN SOURCE Solutions

-  Global Sourcing Solution
-  Obsolete Management
-  Cost Control Management
-  Shortage Management
-  Alternative Solution
-  Excess Inventory Management