



**THE DATASHEET OF
LTC1662IMS8#PBF**



FEATURES

- **Ultralow Power: 1.5 μ A (Typ) I_{CC} per DAC Plus 0.05 μ A Sleep Mode for Extended Battery Life**
- **Tiny: Two 10-Bit DACs in an 8-Lead MSOP—Half the Size of an SO-8**
- Wide 2.7V to 5.5V Supply Range
- Double Buffered for Simultaneous DAC Updates
- **Rail-to-Rail Voltage Outputs Drive 1000pF**
- Reference Range Includes Supply for Ratiometric 0V to V_{CC} Output
- Reference Input Impedance Is Code-Independent (7.1M Ω Typ)—Eliminates External Buffers
- 3-Wire Serial Interface with Schmitt Trigger Inputs
- Differential Nonlinearity: ± 0.75 LSB Max

APPLICATIONS

- Mobile Communications
- Portable Battery-Powered Instruments
- Remote or Inaccessible Adjustments
- Digitally Controlled Amplifiers and Attenuators
- Factory or Field Calibration

LT, LT, LTC, LTM, Linear Technology and the Linear logo are registered trademarks of Linear Technology Corporation. All other trademarks are the property of their respective owners.

DESCRIPTION

The LTC[®]1662 is an ultralow power, fully buffered voltage output, dual 10-bit digital-to-analog converter (DAC). Each DAC channel draws just 1.7 μ A (typ) total supply-plus-reference operating current, yet is capable of supplying DC output currents in excess of 1mA and reliably driving capacitive loads of up to 1000pF. A programmable sleep mode further reduces total operating current to 0.05 μ A.

Linear Technology's proprietary, inherently monotonic architecture provides excellent linearity and an exceptionally small external form factor. The double-buffered input logic provides simultaneous update capability and can be used to write to the DACs without interrupting sleep mode.

With its tiny operating current and exceptionally small size, the LTC1662 is ideal for use in the most power-constrained products. For most designs, there is no perceptible impact on the power budget; the LTC1662 draws many times less current than even a trimpot, while providing buffered, low impedance (0.5 Ω typical, $V_{CC} = 5$ V) rail-to-rail outputs.

The LTC1662 is pin and software compatible with the LTC1661 dual, 60 μ A 10-bit DAC. It is available in 8-pin MSOP and PDIP packages and is specified over the industrial temperature range.

BLOCK DIAGRAM

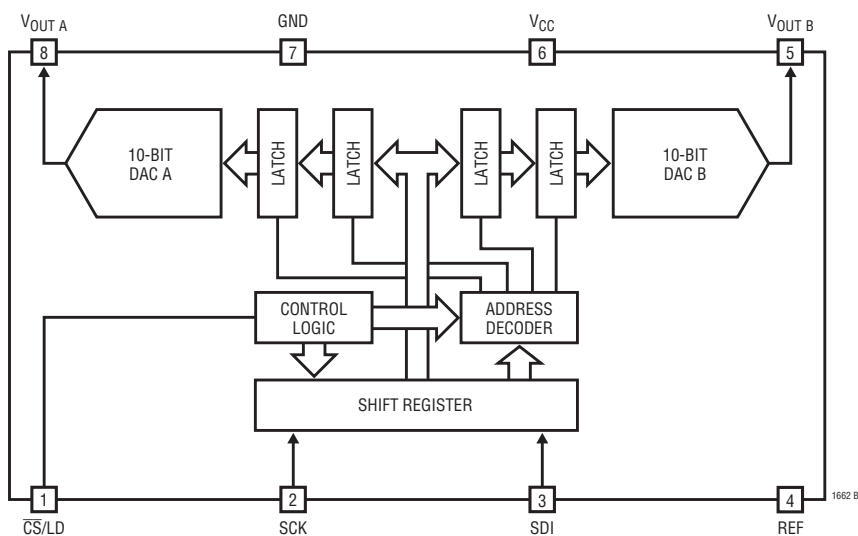

Total Supply-Plus-Reference Operating Current

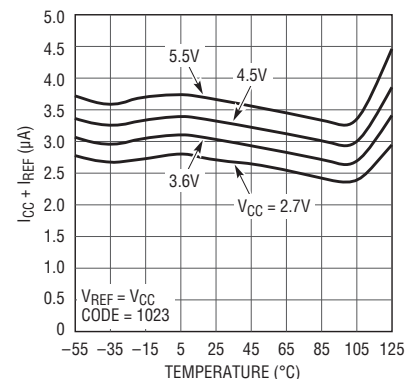

LTC1662

ABSOLUTE MAXIMUM RATINGS

(Note 1)

V_{CC} to GND -0.3V to 7.5V
 Logic Inputs to GND -0.3V to 7.5V
 $V_{OUT A}$, $V_{OUT B}$, REF to GND -0.3V to (V_{CC} + 0.3V)
 Maximum Junction Temperature 125°C
 Storage Temperature Range -65°C to 150°C

Operating Temperature Range
 LTC1662C 0°C to 70°C
 LTC1662I -40°C to 85°C
 Lead Temperature (Soldering, 10 sec)..... 300°C

PIN CONFIGURATION

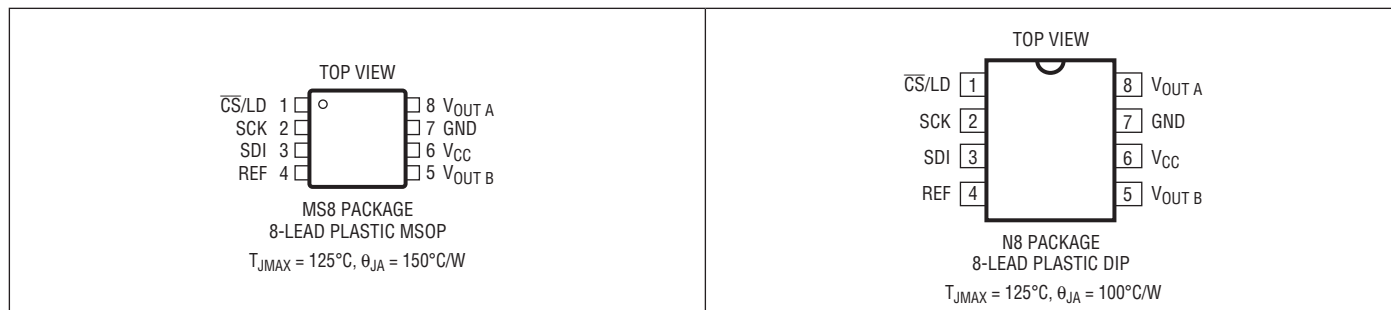

ORDER INFORMATION

LEAD FREE FINISH	TAPE AND REEL	PART MARKING	PACKAGE DESCRIPTION	TEMPERATURE RANGE
LTC1662CMS8#PBF	LTC1662CMS8#TRPBF	LTKB	8-Lead Plastic MSOP	0°C to 70°C
LTC1662IMS8#PBF	LTC1662IMS8#TRPBF	LTKC	8-Lead Plastic MSOP	-40°C to 85°C
LTC1662CN8#PBF	LTC1662CN8#TRPBF	LTC1662CN8	8-Lead Plastic DIP	0°C to 70°C
LTC1662IN8#PBF	LTC1662IN8#TRPBF	LTC1662IN8	8-Lead Plastic DIP	-40°C to 85°C
LEAD BASED FINISH	TAPE AND REEL	PART MARKING	PACKAGE DESCRIPTION	TEMPERATURE RANGE
LTC1662CMS8	LTC1662CMS8#TR	LTKB	8-Lead Plastic MSOP	0°C to 70°C
LTC1662IMS8	LTC1662IMS8#TR	LTKC	8-Lead Plastic MSOP	-40°C to 85°C
LTC1662CN8	LTC1662CN8#TR	LTC1662CN8	8-Lead Plastic DIP	0°C to 70°C
LTC1662IN8	LTC1662IN8#TR	LTC1662IN8	8-Lead Plastic DIP	-40°C to 85°C

Consult LTC Marketing for parts specified with wider operating temperature ranges.

For more information on lead free part marking, go to: <http://www.linear.com/leadfree/>

For more information on tape and reel specifications, go to: <http://www.linear.com/tapeandreeel/>

ELECTRICAL CHARACTERISTICS

The ● denotes the specifications which apply over the full operating temperature range ($T_A = T_{MIN}$ to T_{MAX}), otherwise specifications are at $T_A = 25^\circ\text{C}$. $V_{CC} = 2.7\text{V}$ to 5.5V , $V_{REF} \leq V_{CC}$, V_{OUT} unloaded unless otherwise noted.

SYMBOL	PARAMETER	CONDITIONS	MIN	TYP	MAX	UNITS	
Accuracy							
	Resolution		●	10		Bits	
	Monotonicity	(Note 2)	●	10		Bits	
DNL	Differential Nonlinearity	(Note 2)	●	±0.12	±0.75	LSB	
INL	Integral Nonlinearity	(Note 2)	●	±0.8	±4	LSB	
V_{OS}	Offset Error	$V_{CC} = 5\text{V}$, $V_{REF} = 4.096\text{V}$, Measured at Code 20	●	±5	±25	mV	
V_{OS} TC	V_{OS} Temperature Coefficient			±15		$\mu\text{V}/^\circ\text{C}$	
GE	Gain Error	$V_{CC} = 5\text{V}$, $V_{REF} = 4.096\text{V}$	●	±1	±8	LSB	
GE TC	Gain Error Temperature Coefficient			±12		$\mu\text{V}/^\circ\text{C}$	
PSR	Power Supply Rejection	$V_{REF} = 2.5\text{V}$		0.18		LSB/V	
Reference Input							
	Input Voltage Range		●	0	V_{CC}	V	
	Input Resistance	Active Mode Sleep Mode	●	3.9	7.1 2.5	$\text{M}\Omega$ $\text{G}\Omega$	
	Input Capacitance			10		pF	
Power Supply							
V_{CC}	Positive Supply Voltage	For Specified Performance	●	2.7	5.5	V	
I_{CC}	Supply Current	$V_{CC} = 3\text{V}$ (Note 3) $V_{CC} = 5\text{V}$ (Note 3) $V_{CC} = 3\text{V}$ (Note 3) $V_{CC} = 5\text{V}$ (Note 3)	● ● ● ●		3.0 4.0 3.5 4.5 5.0 5.5	μA μA μA μA	
	Sleep Mode Operating Current	Supply Plus Reference Current, $V_{CC} = V_{REF} = 5\text{V}$ (Note 3)	●		0.05 0.10 0.18	μA μA μA	
DC Performance							
	Short-Circuit Current Low	$V_{OUT} = 0\text{V}$, $V_{CC} = V_{REF} = 5\text{V}$, Code = 1023 (Note 7)	●	5	12	70	mA
	Short-Circuit Current High	$V_{OUT} = V_{CC} = V_{REF} = 5\text{V}$, Code = 0 (Note 7)	●	3	10	80	mA
AC Performance							
	Voltage Output Slew Rate	Rising (Notes 4, 5) Falling (Notes 4, 5)			20 7	V/ms V/ms	
	Voltage Output Settling Time	Rising $0.1V_{FS}$ to $0.9V_{FS} \pm 0.5\text{LSB}$ (Notes 4, 5) Falling $0.9V_{FS}$ to $0.1V_{FS} \pm 0.5\text{LSB}$ (Notes 4, 5)			0.40 0.75	ms ms	
	Capacitive Load Driving				1000	pF	
Digital I/O							
V_{IH}	Digital Input High Voltage	$V_{CC} = 2.7\text{V}$ to 5.5V $V_{CC} = 2.7\text{V}$ to 3.6V	● ●	2.4 2.0		V V	
V_{IL}	Digital Input Low Voltage	$V_{CC} = 4.5\text{V}$ to 5.5V $V_{CC} = 2.7\text{V}$ to 5.5V	● ●		0.8 0.6	V V	
I_{LK}	Digital Input Leakage	$V_{IN} = \text{GND}$ to V_{CC}	●		±0.05	±1.0	μA
C_{IN}	Digital Input Capacitance				1.5	pF	

TIMING CHARACTERISTICS

The ● denotes the specifications which apply over the full operating temperature range, otherwise specifications are at $T_A = 25^\circ\text{C}$.

SYMBOL	PARAMETER	CONDITIONS	MIN	TYP	MAX	UNITS
$V_{CC} = 4.5\text{V to } 5.5\text{V}$						
t_1	SDI Setup	Relative to SCK Positive Edge	●	55		ns
t_2	SDI Hold	Relative to SCK Positive Edge	●	0		ns
t_3	SCK High Time	(Note 6)	●	30		ns
t_4	SCK Low Time	(Note 6)	●	30		ns
t_5	$\overline{\text{CS}}/\text{LD}$ Pulse Width	(Note 6)	●	100		ns
t_6	LSB SCK High to $\overline{\text{CS}}/\text{LD}$ High	(Note 6)	●	30		ns
t_7	$\overline{\text{CS}}/\text{LD}$ Low to SCK High	(Note 6)	●	20		ns
t_9	SCK Low to $\overline{\text{CS}}/\text{LD}$ Low	(Note 6)	●	0		ns
t_{11}	$\overline{\text{CS}}/\text{LD}$ High to SCK Positive Edge	(Note 6)	●	20		ns
	SCK Frequency	Square Wave (Note 6)	●		16.7	MHz
$V_{CC} = 2.7\text{V to } 5.5\text{V}$						
t_1	SDI Setup	Relative to SCK Positive Edge (Note 6)	●	75		ns
t_2	SDI Hold	Relative to SCK Positive Edge (Note 6)	●	0		ns
t_3	SCK High Time	(Note 6)	●	50		ns
t_4	SCK Low Time	(Note 6)	●	50		ns
t_5	$\overline{\text{CS}}/\text{LD}$ Pulse Width	(Note 6)	●	150		ns
t_6	LSB SCK High to $\overline{\text{CS}}/\text{LD}$ High	(Note 6)	●	50		ns
t_7	$\overline{\text{CS}}/\text{LD}$ Low to SCK High	(Note 6)	●	30		ns
t_9	SCK Low to $\overline{\text{CS}}/\text{LD}$ Low	(Note 6)	●	0		ns
t_{11}	$\overline{\text{CS}}/\text{LD}$ High to SCK Positive Edge	(Note 6)	●	30		ns
	SCK Frequency	Square Wave (Note 6)	●		10	MHz

Note 1: Stresses beyond those listed under Absolute Maximum Ratings may cause permanent damage to the device. Exposure to any Absolute Maximum Rating condition for extended periods may affect device reliability and lifetime.

Note 2: Nonlinearity and monotonicity are defined and tested at $V_{CC} = 5\text{V}$, $V_{REF} = 4.096\text{V}$, from code 20 to code 1023. See Figure 2.

Note 3: Digital inputs at 0V or V_{CC} .

Note 4: Load is $10\text{k}\Omega$ in parallel with 100pF .

Note 5: $V_{CC} = V_{REF} = 5\text{V}$. DAC switched between $0.1V_{FS}$ and $0.9V_{FS}$; i.e., codes $k = 102$ and $k = 922$.

Note 6: Guaranteed by design, not subject to test.

Note 7: One DAC output loaded.

TYPICAL PERFORMANCE CHARACTERISTICS

Supply Current vs Temperature

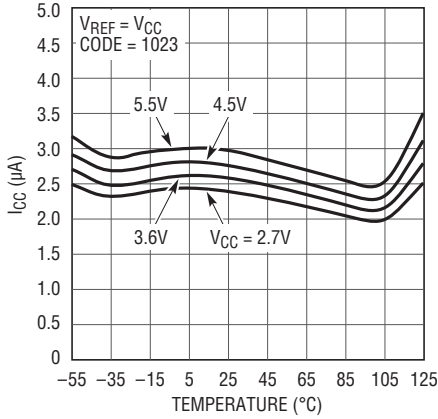

1662 G01

Total Supply-Plus-Reference Operating Current

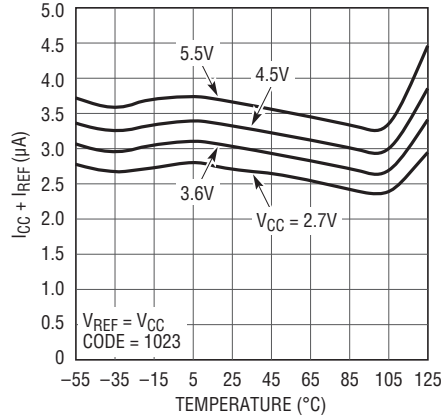

1662 G02

Supply Current vs Clock Frequency

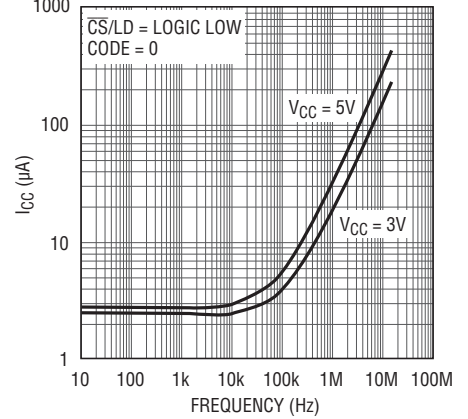

1662 G03

Supply Current vs Logic Input Voltage

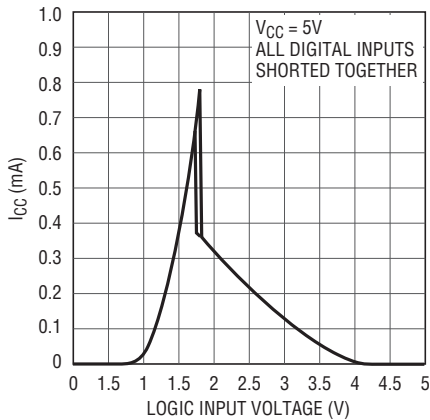

1662 G04

Integral Nonlinearity (INL)

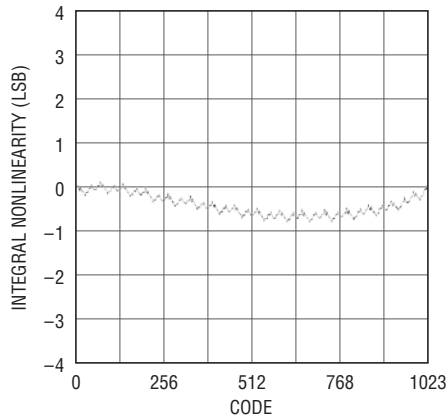

1662 G05

Differential Nonlinearity (DNL)

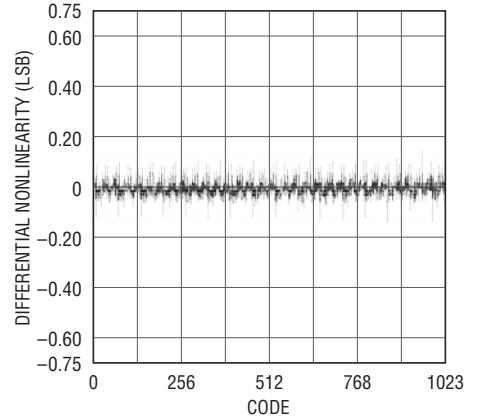

1662 G06

Integral Nonlinearity (INL) vs Reference Voltage

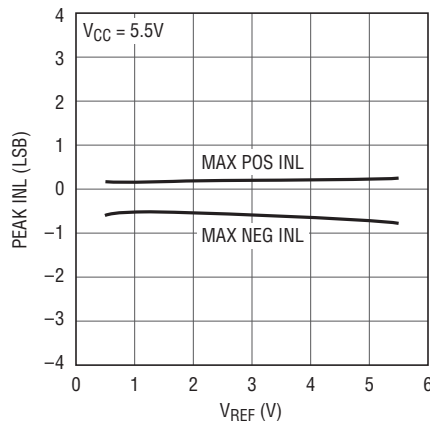

1662 G07

Differential Nonlinearity (DNL) vs Reference Voltage

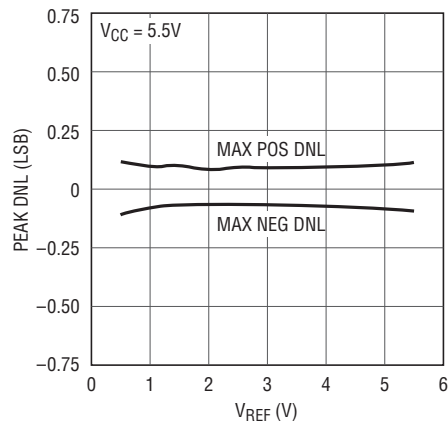

1662 G08

Offset Voltage vs Temperature

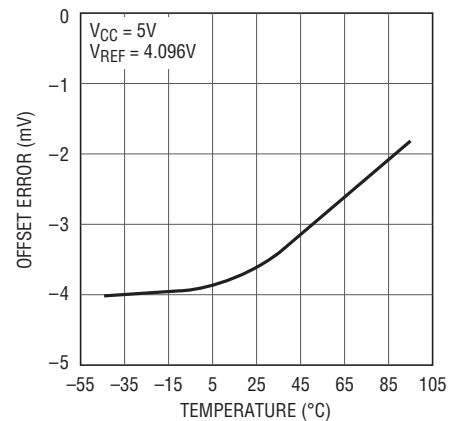

1662 G09

TYPICAL PERFORMANCE CHARACTERISTICS

Gain Error vs Temperature

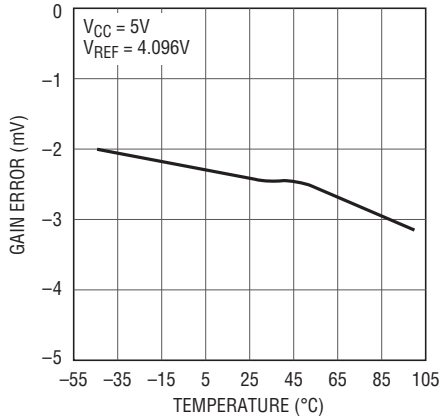

1662 G10

Load Regulation vs Output Current at 5V

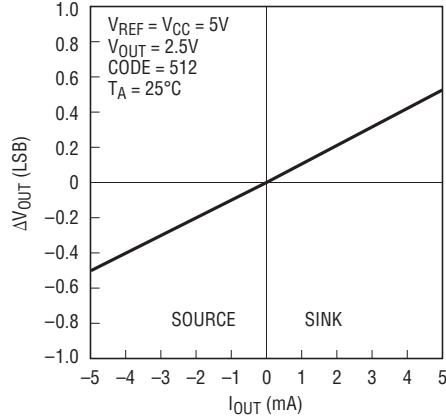

1662 G11

Load Regulation vs Output Current at 3V

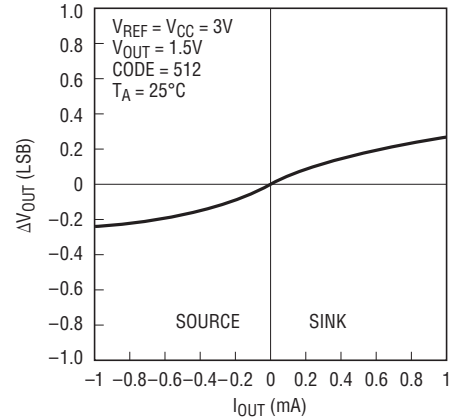

1662 G12

Output Amplifier Current Sourcing Capability (Mid-Scale)

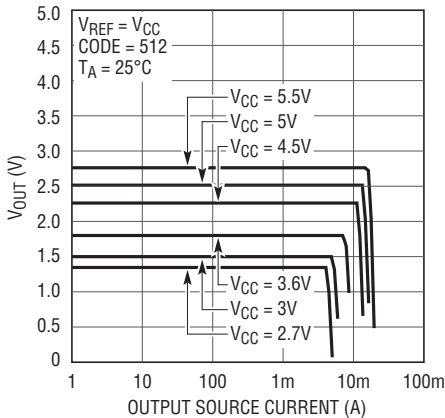

1662 G13

Output Amplifier Current Sinking Capability (Mid-Scale)

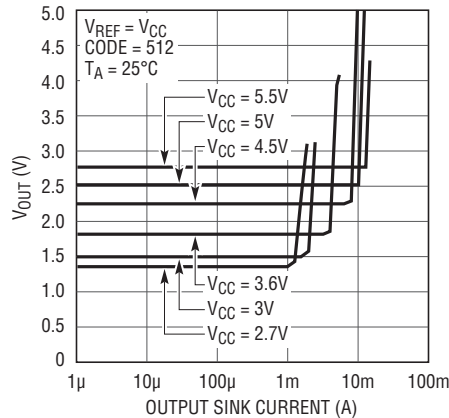

1662 G14

Max/Min Output Voltage vs Source/Sink Output Current ($V_{CC} = 5V$)

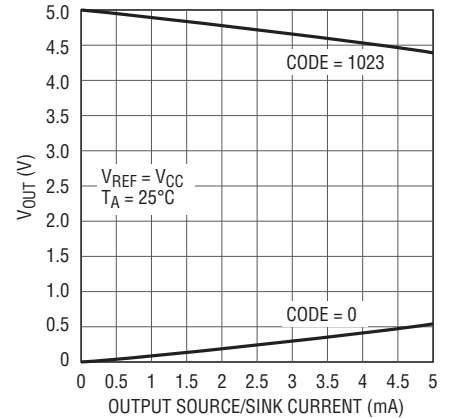

1662 G15

Max/Min Output Voltage vs Source/Sink Output Current ($V_{CC} = 3V$)

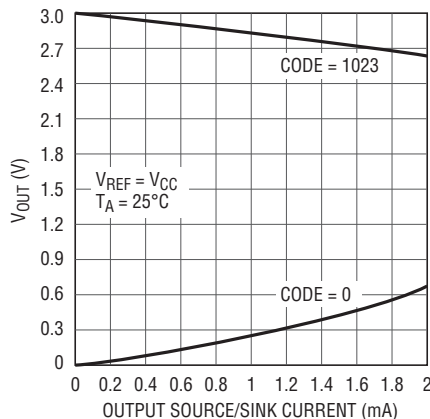

1662 G16

Large-Signal Step Response

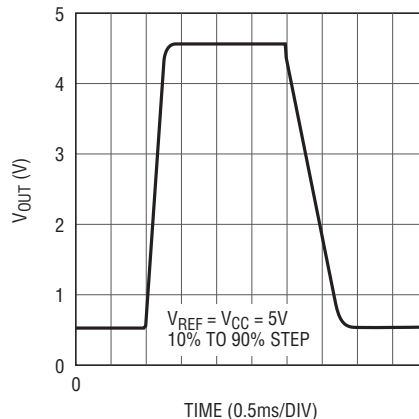

1662 G17

Output Minimum Series Resistance vs Load Capacitance

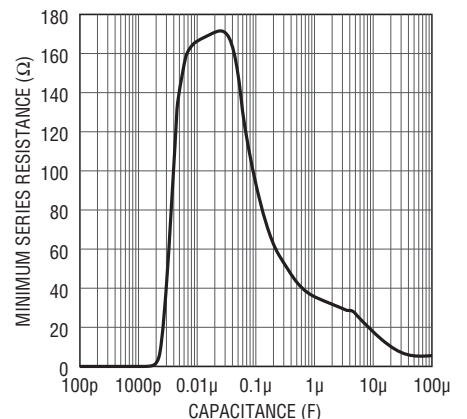

1662 G18

PIN FUNCTIONS

$\overline{\text{CS/LD}}$ (Pin 1): Serial Interface Chip Select/Load Input. When $\overline{\text{CS/LD}}$ is low, SCK is enabled for shifting data on SDI into the register. When $\overline{\text{CS/LD}}$ is pulled high, SCK is disabled and the operation(s) specified in the control code, A3-A0, is (are) performed. CMOS and TTL compatible.

SCK (Pin 2): Serial Interface Clock Input. CMOS and TTL compatible.

SDI (Pin 3): Serial Interface Data Input. Input word data on the SDI pin is shifted into the 16-bit register on the rising edge of SCK. CMOS and TTL compatible.

REF (Pin 4): Reference Voltage Input. $0V \leq V_{\text{REF}} \leq V_{\text{CC}}$.

V_{OUTA} , V_{OUTB} (Pin 8, Pin 5): DAC Analog Voltage Outputs. The output range is

$$0 \leq V_{\text{OUTA}}, V_{\text{OUTB}} \leq V_{\text{REF}} \left(\frac{1023}{1024} \right)$$

V_{CC} (Pin 6): Supply Voltage Input. $2.7V \leq V_{\text{CC}} \leq 5.5V$.

GND (Pin 7): System Ground.

DEFINITIONS

Differential Nonlinearity (DNL): The difference between the measured change and the ideal 1LSB change for any two adjacent codes. The DNL error between any two codes is calculated as follows:

$$\text{DNL} = (\Delta V_{\text{OUT}} - \text{LSB}) / \text{LSB}$$

where ΔV_{OUT} is the measured voltage difference between two adjacent codes.

Full-Scale Error (FSE): The deviation of the actual full-scale voltage from ideal. FSE includes the effects of offset and gain errors (see Figure 2).

Gain Error (GE): The deviation from the slope of the ideal DAC transfer function, expressed in LSBs at full-scale.

Integral Nonlinearity (INL): The deviation from a straight line passing through the endpoints of the DAC transfer curve (endpoint INL). Because the output cannot go below zero, the linearity is measured between full-scale and the lowest code which guarantees the output will be greater than zero. The INL error at a given input code is calculated as follows:

$$\text{INL} = [V_{\text{OUT}} - V_{\text{OS}} - (V_{\text{FS}} - V_{\text{OS}})(\text{code}/1023)] / \text{LSB}$$

where V_{OUT} is the output voltage of the DAC measured at the given input code.

Least Significant Bit (LSB): The ideal voltage difference between two successive codes.

$$\text{LSB} = V_{\text{REF}} / 1024$$

Resolution (n): Defines the number of DAC output states (2^n) that divide the full-scale range. Resolution does not imply linearity.

Voltage Offset Error (V_{OS}): Nominally, the voltage at the output when the DAC is loaded with all zeros. A single supply DAC can have a true negative offset, but the output cannot go below zero (see Figure 2).

For this reason, single supply DAC offset is measured at the lowest code that guarantees the output will be greater than zero.

TIMING DIAGRAM

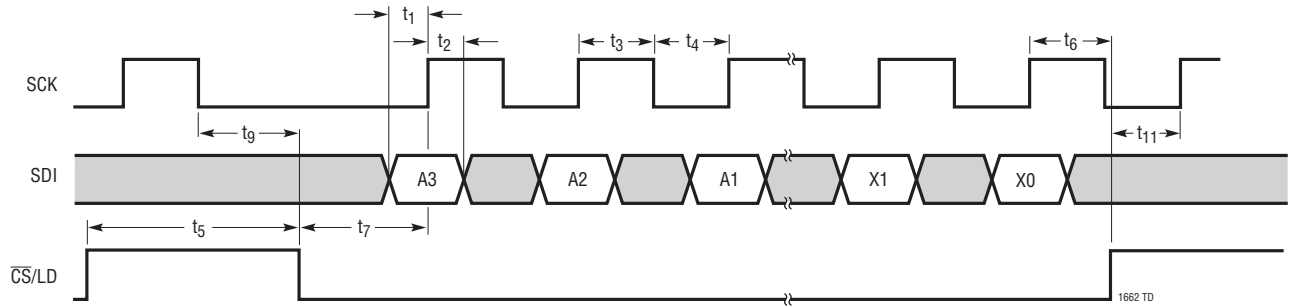

OPERATION

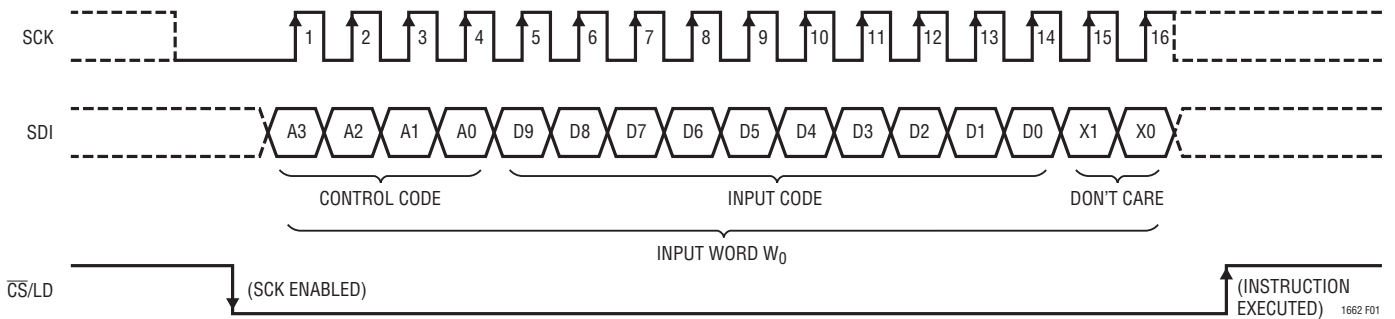

Figure 1. Register Loading Sequence

OPERATION

Table 1. DAC Control Functions

CONTROL				INPUT REGISTER STATUS	DAC REGISTER STATUS	POWER-DOWN STATUS (SLEEP/WAKE)	COMMENTS
A3	A2	A1	A0				
0	0	0	0	No Change	No Update	No Change	No Operation. Power-Down Status Unchanged (Part Stays In Wake or Sleep Mode)
0	0	0	1	Load DAC A	No Update	No Change	Load Input Register A with Data. DAC Outputs Unchanged. Power-Down Status Unchanged
0	0	1	0	Load DAC B	No Update	No Change	Load Input Register B with Data. DAC Outputs Unchanged. Power-Down Status Unchanged
1	0	0	0	No Change	Update Outputs	Wake	Load Both DAC Regs with Existing Contents of Input Regs. Outputs Update. Part Wakes Up
1	0	0	1	Load DAC A	Update Outputs	Wake	Load Input Reg A. Load DAC Regs with New Contents of Input Reg A and Existing Contents of Reg B. Outputs Update. Part Wakes Up
1	0	1	0	Load DAC B	Update Outputs	Wake	Load Input Reg B. Load DAC Regs with Existing Contents of Input Reg A and New Contents of Reg B. Outputs Update. Part Wakes Up
1	1	0	1	No Change	No Update	Wake	Part Wakes Up. Input and DAC Regs Unchanged. DAC Outputs Reflect Existing Contents of DAC Regs
1	1	1	0	No Change	No Update	Sleep	Part Goes to Sleep. Input and DAC Regs Unchanged. DAC Outputs Set to High Impedance State
1	1	1	1	Load DACs A, B with Same 10-Bit Code	Update Outputs	Wake	Load Both Input Regs. Load Both DAC Regs with New Contents of Input Regs. Outputs Update. Part Wakes Up

Note: All control codes other than those shown are undefined and not subject to test.

Transfer Function

The transfer function for the LTC1662 is:

$$V_{\text{OUT(IDEAL)}} = \left(\frac{k}{1024} \right) V_{\text{REF}}$$

where k is the decimal equivalent of the binary DAC input code D9-D0 and V_{REF} is the voltage at REF (Pin 4).

Power-On Reset

The LTC1662 actively clears the outputs to zero-scale when power is first applied, making system initialization consistent and repeatable.

Power Supply Sequencing

The voltage at REF (Pin 4) should be kept within the range $-0.3V \leq V_{\text{REF}} \leq V_{\text{CC}} + 0.3V$ (see the Absolute Maximum Ratings). Particular care should be taken during power supply turn-on and turn-off sequences, when the voltage at

V_{CC} (Pin 6) is in transition. If it is not possible to sequence the supplies, clamp the voltage at REF by connecting a Schottky diode between Pin 4 (anode) and Pin 6 (cathode).

Serial Interface

See Table 2. The 16-bit input word consists of the 4-bit control code, the 10-bit input code and two don't-care bits.

Table 2. LTC1662 Input Word

Input Word															
A3	A2	A1	A0	D9	D8	D7	D6	D5	D4	D3	D2	D1	D0	X1	X0
Control Code				Input Code										Don't Care	

After the input word is loaded into the register (see Figure 1), it is internally converted from serial to parallel format. The parallel 10-bit-wide input code data path is then buffered by two latch registers.

OPERATION

The first of these, the input register, is used for loading new input codes. The second buffer, the DAC register, is used for updating the DAC outputs. Each DAC has its own 10-bit input register and 10-bit DAC register.

By selecting the appropriate 4-bit control code (see Table 1) it is possible to perform single operations, such as loading one DAC or changing power-down status (sleep/wake). In addition, some control codes perform two or more operations at the same time. For example, one such code loads DAC A, updates both outputs and Wakes the part up. The DACs can be loaded separately or together, but the outputs are always updated together.

Register Loading Sequence

See Figure 1. With \overline{CS}/LD held low, data on the SDI input is shifted into the 16-bit shift register on the positive edge of SCK. The 4-bit control code, A3-A0, is loaded first, then the 10-bit input code, D9-D0, ordered MSB to LSB in each case. Two don't-care bits, X1 and X0, are loaded last. When the full 16-bit input word has been shifted in, \overline{CS}/LD is pulled high, causing the system to respond according to Table 1. The clock is disabled internally when \overline{CS}/LD is high. Note: SCK must be low when \overline{CS}/LD is pulled low.

Sleep Mode

DAC control code 1110_b is reserved for the special sleep instruction (see Table 1). In this mode, static power consumption is greatly reduced. The reference input and analog outputs are set in a high impedance state and all DAC settings are retained in memory so that when sleep mode is exited, the outputs of DACs not updated by the Wake command are restored to their last active state.

Sleep mode is initiated by performing a load sequence using control code 1110_b (the DAC input code D9-D0 is ignored).

To save instruction cycles, the DACs may be prepared with new input codes during sleep (control codes 0001_b

and 0010_b); then, a single command (1000_b) can be used both to wake the part and to update the output values.

Alternatively, one DAC may be loaded with a new input code during sleep; then with just one command, the other DAC is loaded, the part is awakened and both outputs are updated.

For example, control code 0001_b is used to load DAC A during sleep. Then control code 0101_b loads DAC B, wakes the part and simultaneously updates both DAC outputs.

Voltage Outputs

Each of the rail-to-rail output amplifiers contained in the LTC1662 can typically source or sink at least 1mA ($V_{CC} = 5V$). The outputs swing to within a few millivolts of either supply when unloaded and have an equivalent output resistance of 130 Ω (typical) when driving a load to the rails. The output amplifiers are stable driving capacitive loads of up to 1000pF.

A small resistor placed in series with the output can be used to achieve stability for any load capacitance. Please see the Output Minimum Resistance vs Load Capacitance curve in the Typical Performance Characteristics section.

Rail-to-Rail Output Considerations

In any rail-to-rail DAC, the output swing is limited to voltages within the supply range.

If the DAC offset is negative, the output for the lowest codes limits at 0V as shown in Figure 2b.

Similarly, limiting can occur near full-scale when the REF pin is tied to V_{CC} . If $V_{REF} = V_{CC}$ and the DAC full-scale error ($FSE = V_{OS} + GE$) is positive, the output for the highest codes limits at V_{CC} as shown in Figure 2c. No full-scale limiting can occur if V_{REF} is less than $V_{CC} - FSE$.

Offset and linearity are defined and tested over the region of the DAC transfer function where no output limiting can occur.

OPERATION

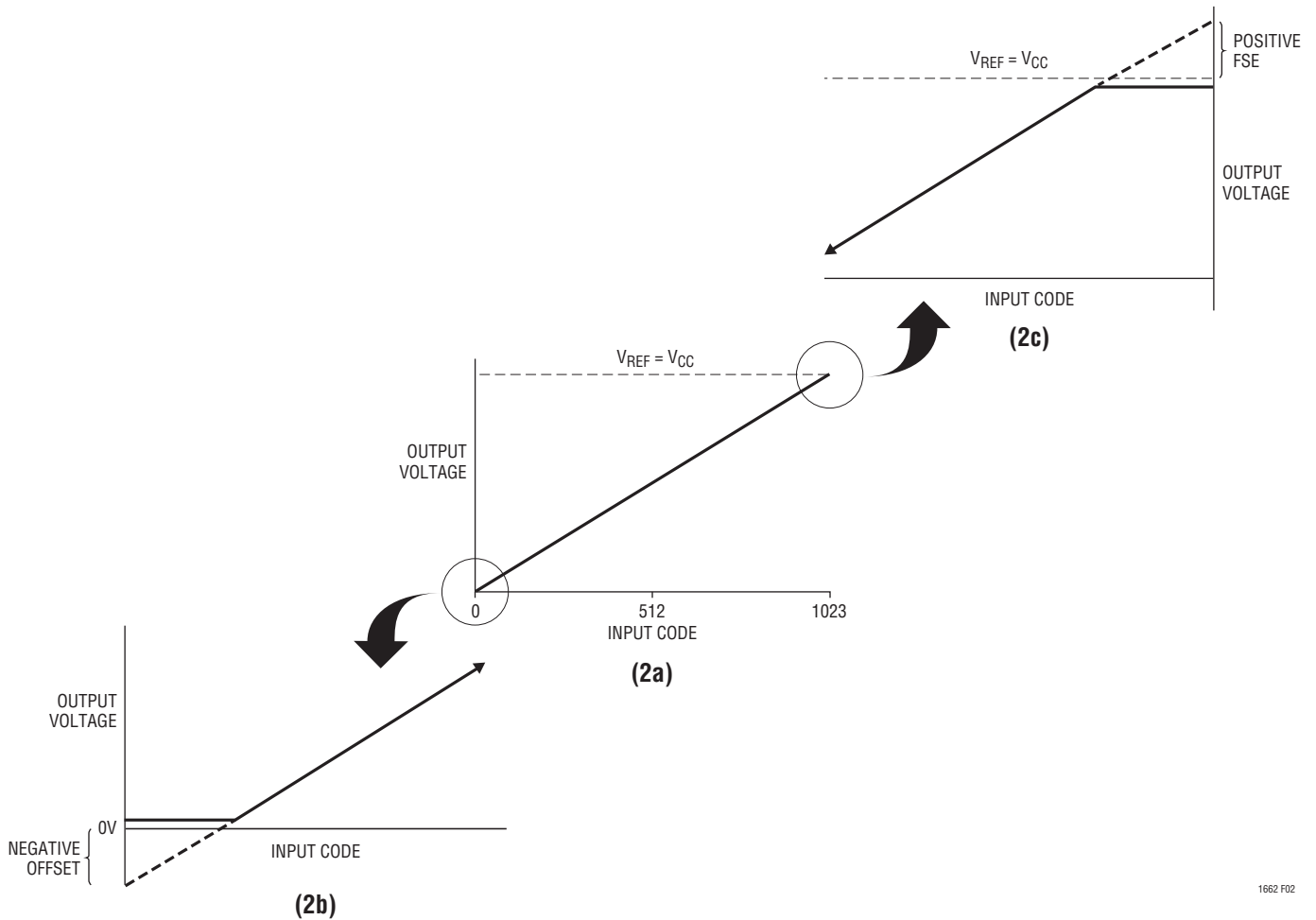

1662 F02

Figure 2. Effects of Rail-to-Rail Operation On a DAC Transfer Curve. (a) Overall Transfer Function (b) Effect of Negative Offset for Codes Near Zero-Scale (c) Effect of Positive Full-Scale Error for Input Codes Near Full-Scale When $V_{REF} = V_{CC}$

TYPICAL APPLICATIONS

Micropower Trim Circuit with Coarse/Fine Adjustment. Total Supply Current Is 9.5µA

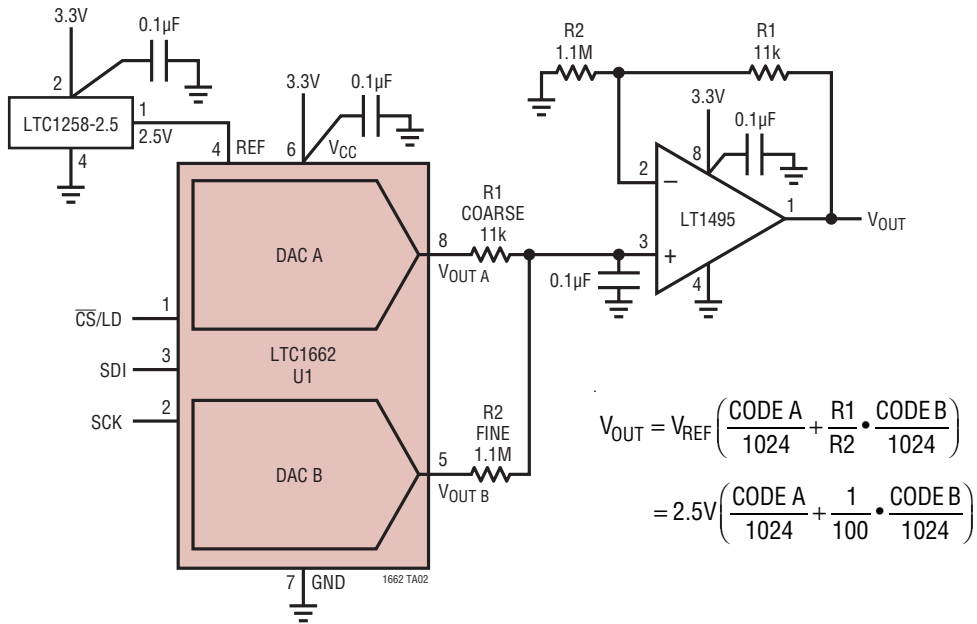

Using the LTC1258 and the LTC1662 in a Portable Application Powered by a Single Li-Ion Battery. Total Supply Current Is 8.2µA

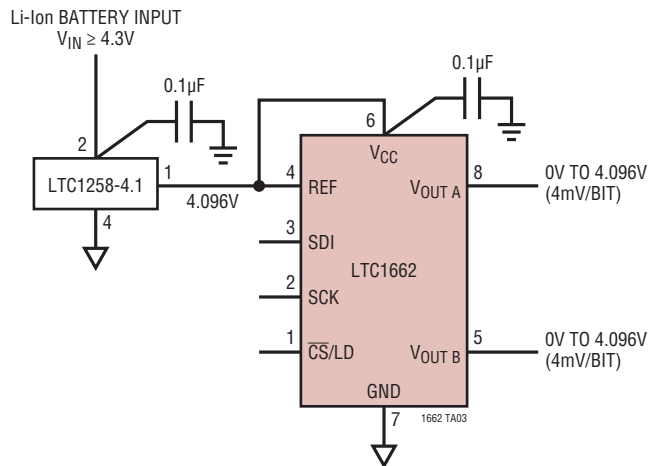

PACKAGE DESCRIPTION

Please refer to <http://www.linear.com/designtools/packaging/> for the most recent package drawings.

MS8 Package 8-Lead Plastic MSOP

(Reference LTC DWG # 05-08-1660 Rev F)

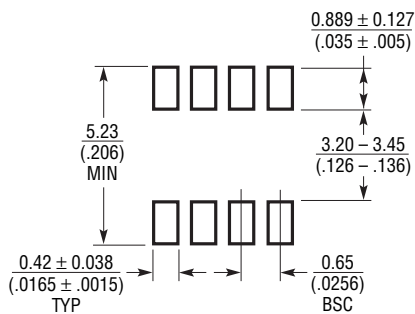

RECOMMENDED SOLDER PAD LAYOUT

NOTE:

1. DIMENSIONS IN MILLIMETER/(INCH)
2. DRAWING NOT TO SCALE
3. DIMENSION DOES NOT INCLUDE MOLD FLASH, PROTRUSIONS OR GATE BURRS.
MOLD FLASH, PROTRUSIONS OR GATE BURRS SHALL NOT EXCEED 0.152mm (.006") PER SIDE
4. DIMENSION DOES NOT INCLUDE INTERLEAD FLASH OR PROTRUSIONS.
INTERLEAD FLASH OR PROTRUSIONS SHALL NOT EXCEED 0.152mm (.006") PER SIDE
5. LEAD COPLANARITY (BOTTOM OF LEADS AFTER FORMING) SHALL BE 0.102mm (.004") MAX

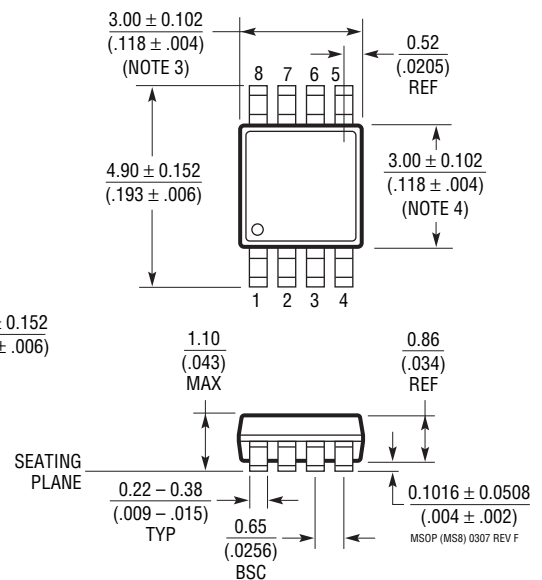
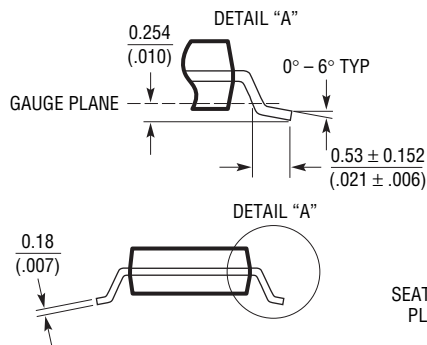

PACKAGE DESCRIPTION

Please refer to <http://www.linear.com/designtools/packaging/> for the most recent package drawings.

N Package
8-Lead PDIP (Narrow .300 Inch)
 (Reference LTC DWG # 05-08-1510 Rev I)

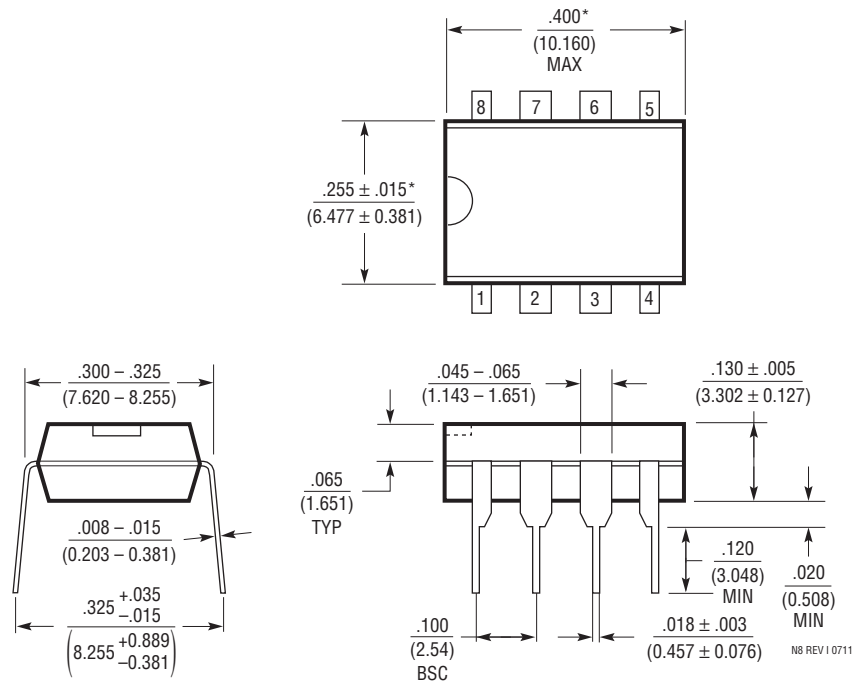

NOTE:
 1. DIMENSIONS ARE $\frac{\text{INCHES}}{\text{MILLIMETERS}}$
 *THESE DIMENSIONS DO NOT INCLUDE MOLD FLASH OR PROTRUSIONS.
 MOLD FLASH OR PROTRUSIONS SHALL NOT EXCEED .010 INCH (0.254mm)

REVISION HISTORY

REV	DATE	DESCRIPTION	PAGE NUMBER
A	01/12	Removed Typical values in the Timing Characteristics section. Corrected Related Parts listing for the LTC1659.	4 16

TYPICAL APPLICATION

Ultralow Power DAC Optimizes Mixer Performance

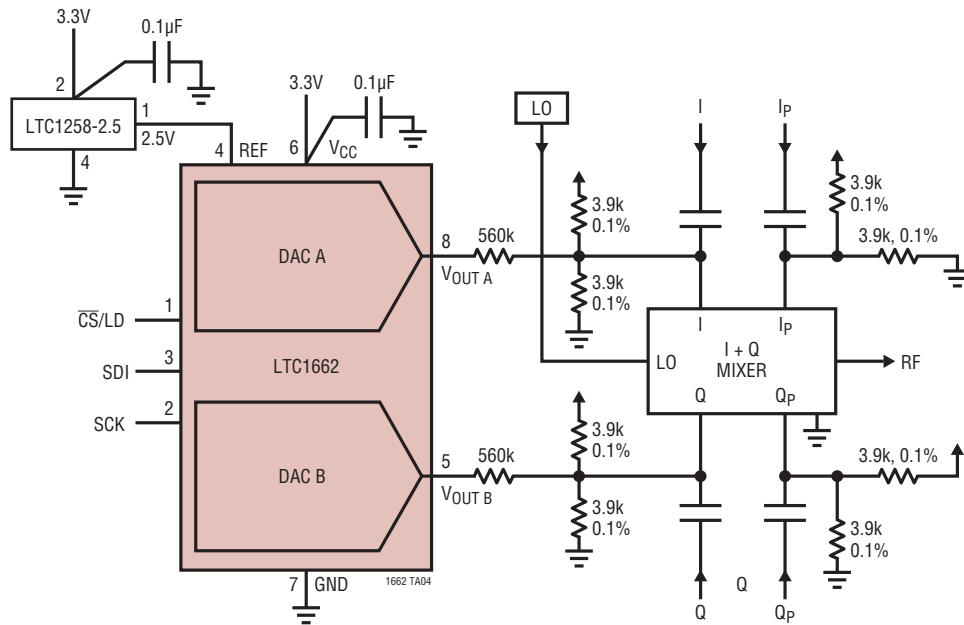

RELATED PARTS

PART NUMBER	DESCRIPTION	COMMENTS
LTC1661	Dual 10-Bit V _{OUT} DAC in 8-Lead MSOP Package	V _{CC} = 2.7V to 5.5V, 60μA per DAC, Rail-to-Rail Output
LTC1663	Single 10-Bit V _{OUT} DAC with 2-Wire Interface in SOT-23 Package	V _{CC} = 2.7V to 5.5V, Internal Reference, 60μA
LTC1664	Quad 10-Bit V _{OUT} DAC in 16-Pin Narrow SSOP	V _{CC} = 2.7V to 5.5V, 60μA per DAC, Rail-to-Rail Output
LTC1665/LTC1660	Octal 8-/10-Bit V _{OUT} DAC in 16-Pin Narrow SSOP	V _{CC} = 2.7V to 5.5V, 60μA per DAC, Rail-to-Rail Output
LTC1446/LTC1446L	Dual 12-Bit V _{OUT} DACs in SO-8 Package with Internal Reference	LTC1446: V _{CC} = 4.5V to 5.5V, V _{OUT} = 0V to 4.095V LTC1446L: V _{CC} = 2.7V to 5.5V, V _{OUT} = 0V to 2.5V
LTC1448	Dual 12-Bit V _{OUT} DAC in SO-8 Package	V _{CC} = 2.7V to 5.5V, External Reference Can Be Tied to V _{CC}
LTC1454/LTC1454L	Dual 12-Bit V _{OUT} DACs in SO-16 Package with Added Functionality	LTC1454: V _{CC} = 4.5V to 5.5V, V _{OUT} = 0V to 4.095V LTC1454L: V _{CC} = 2.7V to 5.5V, V _{OUT} = 0V to 2.5V
LTC1458/LTC1458L	Quad 12-Bit Rail-to-Rail Output DACs with Added Functionality	LTC1458: V _{CC} = 4.5V to 5.5V, V _{OUT} = 0V to 4.095V LTC1458L: V _{CC} = 2.7V to 5.5V, V _{OUT} = 0V to 2.5V
LTC1659	Single Rail-to-Rail 12-Bit V _{OUT} DAC in 8-Lead MSOP Package	V _{CC} = 2.7V to 5.5V, Low Power Multiplying V _{OUT} DAC. Output Swings from GND to REF. REF Input Can Be Tied to V _{CC}

Looking for pricing, stock, or lifecycle information?

Click below to explore more details on WIN SOURCE:

 [View LTC1662IMS8#PBF on WIN SOURCE](#)

 [Linear Technology](#) Information

Optimize Your Supply Chain with WIN SOURCE Solutions

-  Global Sourcing Solution
-  Obsolete Management
-  Cost Control Management
-  Shortage Management
-  Alternative Solution
-  Excess Inventory Management