



**3.3V/5V PECL/ECL  
3GHz DIFFERENTIAL  
4:1 MULTIPLEXER**

**ECL Pro™  
SY100EP57V**

**FEATURES**

- Fully differential 4:1 PECL/ECL multiplexer
- Guaranteed AC-parameters over temp/voltage:
  - > 3GHz Fmax (toggle)
  - < 220ps rise/fall Time
  - < 520ps propagation delay (D-to-Q)
- Flexible power supply: 3.0V to 5.5V
- Wide operating temp range: -40°C to +85°C
- V<sub>BB</sub> reference for AC-coupled and single-ended applications
- 100k PECL/ECL compatible logic
- Available in 20-pin TSSOP package

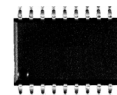

**ECL Pro™**

**DESCRIPTION**

The SY100EP57V is a high-speed, low-skew, fully differential PECL/ECL 4:1 multiplexer in a 20-pin TSSOP package. This device is a pin-for-pin, plug-in replacement to the MC10/100EP57DT. The signal-path inputs (D0:D3) accept differential signals as low as 150mVpk-pk. All I/O pins are 100K EP PECL/ECL logic compatible.

AC-performance is guaranteed over the industrial -40°C to +85°C temperature range and 3.0V to 5.5V supply voltage range. This device will operate in PECL/LVPECL or ECL/LVECL mode. The SY100EP57 propagation delay is less than 520ps, and the Select-to-valid output delay is less than 575ps over temperature and voltage. For clock applications, the high-speed design combined with an extremely fast rise/fall time of less than 220ps produces a toggle frequency as high as 3GHz (400mVpk-pk swing). Two V<sub>BB</sub> output reference pins (approx equal to V<sub>CC</sub>-1.4V) are available for AC-coupled or single-ended applications.

The SY100EP57V is part of Micrel's high-speed, Precision Edge timing and distribution family. For applications that require a different I/O combination, consult the Micrel website at [www.micrel.com](http://www.micrel.com), and choose from a comprehensive product line of high-speed, low skew fanout buffers, translators, and clock dividers.

**CROSS REFERENCE TABLE**

Micrel Semiconductor	ON Semiconductor
SY100EP57VK4I	MC100EP57DT
SY100EP57VK4ITR	MC100EP57DTR2

**PACKAGE/ORDERING INFORMATION**

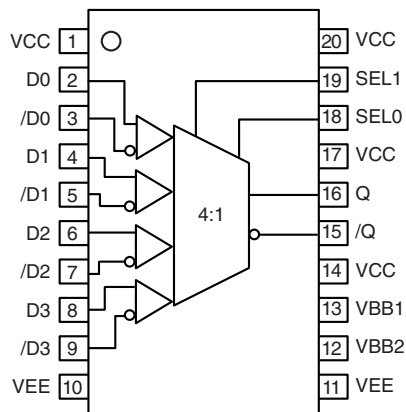

**20-Pin TSSOP (K4-20-1)**

**Ordering Information<sup>(1)</sup>**

Part Number	Package Type	Operating Range	Package Marking	Lead Finish
SY100EP57VK4I	K4-20-1	Industrial	XEP57V	Sn-Pb
SY100EP57VK4ITR <sup>(2)</sup>	K4-20-1	Industrial	XEP57V	Sn-Pb
SY100EP57VK4G <sup>(3)</sup>	K4-20-1	Industrial	XEP57V with Pb-Free bar-line indicator	Pb-Free NiPdAu
SY100EP57VK4GTR <sup>(2, 3)</sup>	K4-20-1	Industrial	XEP57V with Pb-Free bar-line indicator	Pb-Free NiPdAu

**Notes:**

1. Contact factory for die availability. Dice are guaranteed at  $T_A = 25^\circ\text{C}$ , DC Electricals only.
2. Tape and Reel.
3. Pb-Free package is recommended for new designs.

**PIN DESCRIPTION**

Pin	Pin Number	Function
D0: D3 /D0: /D3	2, 4, 6, 8 3, 5, 7, 9	Input Channels 0-3 PECL/ECL differential signal inputs. Multiplexing of these 4 differential inputs is controlled by SEL0, SEL1. The signal inputs include internal 75kΩ pull-down resistors. Default condition is LOW when left floating. The input signal should be terminated externally. See "Termination" section
VEE	10, 11	Negative Power Supply: For PECL/LVPECL applications, connect to Ground. Both $V_{EE}$ pins must be connected together, externally on the PCB, for proper operation.
VBB1, VBB2	13, 12	Reference output voltage. This reference is typically used to bias the unused inverting input for single-ended input applications, or as the termination point for AC-coupled differential input applications. $V_{BB}$ reference value is approximately $V_{CC} - 1.4\text{V}$ , and tracks $V_{CC}$ 1:1. Maximum sink/source capability for each $V_{BB}$ reference pin is 0.50mA. For single ended PECL inputs, connect to the unused input through a 50Ω resistor. Decouple the $V_{BB}$ pin with a 0.01μF capacitor. For PECL/LVPECL inputs, the decoupling capacitor is connected to $V_{CC}$ , since PECL signals are referenced to $V_{CC}$ . Leave floating if not used.
/Q, Q	15, 16	100KEP PECL/ECL compatible differential output. PECL/ECL termination is with a 50Ω resistor to $V_{CC} - 2\text{V}$ . Unused single-ended outputs must have a balanced load. For AC-coupled applications, the output stage emitter follower must have a DC current path to ground. See "Termination" section.
SEL0, SEL1	18, 19	100KEP PECL/ECL compatible 4:1 MUX select control. See "MUX Select Truth Table." Each pin includes an internal 75kΩ pull-down resistor. Default condition when left floating is LOW.
VCC	1, 14, 17, 20	Positive Power Supply. All $V_{CC}$ pins must be connected to the same power supply externally. Bypass with 0.1μF//0.01μF low ESR capacitors.

**MUX SELECT TRUTH TABLE**

SEL1	SEL0	DATA OUT
L	L	D0, /D0
L	H	D1, /D1
H	L	D2, /D2
H	H	D3, /D3

**ABSOLUTE MAXIMUM RATINGS<sup>(1)</sup>**

Symbol	Rating	Value	Unit
$V_{CC} - V_{EE}$	Power Supply Voltage	6.0	V
$V_{IN}$	Input Voltage ( $V_{CC} = 0V$ , $V_{IN}$ not more negative than $V_{EE}$ )	-6.0 to 0	V
	Input Voltage ( $V_{EE} = 0V$ , $V_{IN}$ not more positive than $V_{CC}$ )	+6.0 to 0	V
$I_{OUT}$	Output Current	-Continuous	50
		-Surge	100
$I_{BB}$	$V_{BB}$ Sink/Source Current <sup>(2)</sup>	±0.5	mA
$T_{LEAD}$	Lead Temperature (soldering, 20sec.)	+260	°C
$T_A$	Operating Temperature Range	-40 to +85	°C
$T_{store}$	Storage Temperature Range	-65 to +150	°C
$\theta_{JA}$	Package Thermal Resistance (Junction-to-Ambient)	-Still-Air (single-layer PCB)	115
		-Still-Air (multi-layer PCB)	75
		-500lfpm (multi-layer PCB)	65
$\theta_{JC}$	Package Thermal Resistance (Junction-to-Case)	21	°C/W

**Notes:**

1. Permanent device damage may occur if absolute maximum ratings are exceeded. This is a stress rating only and functional operation is not implied at conditions other than those detailed in the operational sections of this data sheet. Exposure to absolute maximum rating conditions for extended periods may affect device reliability.
2. Due to the limited drive capability, the  $V_{BB}$  reference should only be used for inputs from the same package device (i.e., do not sue for other devices).

**DC ELECTRICAL CHARACTERISTICS<sup>(1)</sup>**

Symbol	Parameter	$T_A = -40^\circ\text{C}$			$T_A = +25^\circ\text{C}$			$T_A = +85^\circ\text{C}$			Unit	Condition
		Min.	Typ.	Max.	Min.	Typ.	Max.	Min.	Typ.	Max.		
$V_{CC}$	Power Supply Voltage										V	
	(PECL)	4.5	5.0	5.5	4.5	5.0	5.5	4.5	5.0	5.5		
	(LVPECL)	3.0	—	3.8	3.0	—	3.8	3.0	—	3.8		
	(ECL)	-5.5	-5.0	-4.5	-5.5	-5.0	-4.5	-5.5	-5.0	-4.5		
	(LVECL)	-3.8	-3.3	-3.0	-3.8	-3.3	-3.0	-3.8	-3.3	-3.0		
$I_{EE}$	Supply Current	—	35	50	—	35	50	—	35	50	mA	No Load
$I_{IH}$	Input HIGH Current	—	—	75	—	—	75	—	—	80	μA	$V_{IN} = V_{IH}$
$I_{IL}$	Input LOW Current											
	All Inputs	0.5	—	—	0.5	—	—	0.5	—	—	μA	$V_{IN} = V_{IL}$
$C_{IN}$	Input Capacitance (TSSOP)	—	—	—	—	1.0	—	—	—	—	pF	

**Note:**

1. 100KEP circuits are designed to meet the DC specifications shown in the above table after thermal equilibrium has been established. The circuit is in a test socket or mounted on a printed circuit board and traverse airflow greater than 500lfpm is maintained.

**(100KEP) LVPECL DC ELECTRICAL CHARACTERISTICS<sup>(1)</sup>** $V_{CC} = 3.3V \pm 10\%$ ,  $V_{EE} = 0V$ 

Symbol	Parameter	$T_A = -40^\circ C$			$T_A = +25^\circ C$			$T_A = +85^\circ C$			Unit	Condition
		Min.	Typ.	Max.	Min.	Typ.	Max.	Min.	Typ.	Max.		
$V_{IL}$	Input LOW Voltage (Single-Ended)	1355	—	1675	1355	—	1675	1355	—	1675	mV	
$V_{IH}$	Input HIGH Voltage (Single-Ended)	2075	—	2420	2075	—	2420	2075	—	2420	mV	
$V_{OL}$	Output LOW Voltage	1355	1480	1605	1355	1480	1605	1355	1480	1605	mV	50Ω to $V_{CC}-2V$
$V_{OH}$	Output HIGH Voltage	2155	2280	2405	2155	2280	2405	2155	2280	2405	mV	50Ω to $V_{CC}-2V$
$V_{BB}$	Output Reference Voltage	1775	1875	1975	1775	1875	1975	1775	1875	1975	mV	
$V_{IHCMR}$	Input HIGH Voltage <sup>(2)</sup> Common Mode Range	2.0	—	$V_{CC}$	2.0	—	$V_{CC}$	2.0	—	$V_{CC}$	V	

**Notes:**

- 100KEP circuits are designed to meet the DC specifications shown in the above table after thermal equilibrium has been established. The circuit is in a test socket or mounted on a printed circuit board and traverse airflow greater than 500fpm is maintained. Input and output parameters are at  $V_{CC} = 3.3V$ . They vary 1:1 with  $V_{CC}$ .
- The  $V_{IHCMR}$  range is referenced to the most positive side of the differential input signal.

**(100KEP) PECL DC ELECTRICAL CHARACTERISTICS<sup>(1)</sup>** $V_{CC} = 5.0V \pm 10\%$ ,  $V_{EE} = 0V$ 

Symbol	Parameter	$T_A = -40^\circ C$			$T_A = +25^\circ C$			$T_A = +85^\circ C$			Unit	Condition
		Min.	Typ.	Max.	Min.	Typ.	Max.	Min.	Typ.	Max.		
$V_{IL}$	Input LOW Voltage (Single-Ended)	3055	—	3375	3055	—	3375	3055	—	3375	mV	
$V_{IH}$	Input HIGH Voltage (Single-Ended)	3775	—	4120	3775	—	4120	3775	—	4120	mV	
$V_{OL}$	Output LOW Voltage	3055	3180	3305	3055	3180	3305	3055	3180	3305	mV	50Ω to $V_{CC}-2V$
$V_{OH}$	Output HIGH Voltage	3855	3980	4105	3855	3980	4105	3855	3980	4105	mV	50Ω to $V_{CC}-2V$
$V_{BB}$	Output Reference Voltage	3475	3575	3675	3475	3575	3675	3475	3575	3675	mV	
$V_{IHCMR}$	Input HIGH Voltage <sup>(2)</sup> Common Mode Range	2.0	—	$V_{CC}$	2.0	—	$V_{CC}$	2.0	—	$V_{CC}$	V	

**Notes:**

- 100KEP circuits are designed to meet the DC specifications shown in the above table after thermal equilibrium has been established. The circuit is in a test socket or mounted on a printed circuit board and traverse airflow greater than 500fpm is maintained. Input and output parameters are at  $V_{CC} = 3.3V$ . They vary 1:1 with  $V_{CC}$ .
- The  $V_{IHCMR}$  range is referenced to the most positive side of the differential input signal.

**(100KEP) ECL/LVECL DC ELECTRICAL CHARACTERISTICS<sup>(1)</sup>** $V_{CC} = 0V$ ,  $V_{EE} = -5.5V$  to  $-3.0V$ 

Symbol	Parameter	$T_A = -40^\circ C$			$T_A = +25^\circ C$			$T_A = +85^\circ C$			Unit	Condition
		Min.	Typ.	Max.	Min.	Typ.	Max.	Min.	Typ.	Max.		
$V_{IL}$	Input LOW Voltage	-1945	—	-1625	-1945	—	-1625	-1945	—	-1625	mV	
$V_{IH}$	Input HIGH Voltage	-1225	—	-880	-1225	—	-880	-1225	—	-880	mV	
$V_{OL}$	Output LOW Voltage	-1945	-1820	-1695	-1945	-1820	-1695	-1945	-1820	-1695	mV	50Ω to $V_{CC}-2V$
$V_{OH}$	Output HIGH Voltage	-1145	-1020	-895	-1145	-1020	-895	-1145	-1020	-895	mV	50Ω to $V_{CC}-2V$
$V_{BB}$	Output Reference Voltage	-1525	-1425	-1325	-1525	-1425	-1325	-1525	-1425	-1325	mV	
$V_{IHCMR}$	Input HIGH Voltage <sup>(2)</sup> Common Mode Range	$V_{EE} + 2.0$		0.0	$V_{EE} + 2.0$		0.0	$V_{EE} + 2.0$		0.0	V	

**Notes:**

- 100KEP circuits are designed to meet the DC specifications shown in the above table after thermal equilibrium has been established. The circuit is in a test socket or mounted on a printed circuit board and traverse airflow greater than 500fpm is maintained. Input and output parameters are at  $V_{CC} = 3.3V$ . They vary 1:1 with  $V_{CC}$ .
- The  $V_{IHCMR}$  range is referenced to the most positive side of the differential input signal.

**AC ELECTRICAL CHARACTERISTICS** $V_{CC} = 0V$ ;  $V_{EE} = -3.0V$  to  $-5.5V$  or  $V_{CC} = 3.0V$  to  $5.5V$ ,  $V_{EE} = 0V$ 

Symbol	Parameter	$T_A = -40^\circ C$			$T_A = +25^\circ C$			$T_A = +85^\circ C$			Unit	Condition
		Min.	Typ.	Max.	Min.	Typ.	Max.	Min.	Typ.	Max.		
$f_{MAX}$	Max. Toggle Frequency <sup>(1)</sup>	3	—	—	3	—	—	3	—	—	GHz	
$t_{PLH}$ $t_{PHL}$	Propagation Delay (Differential) D to Q, /Q SEL to Q, /Q	250 300	310 370	450 500	250 300	315 380	475 520	250 300	320 390	520 575	ps ps	
$t_{SKEW}$	Part-to-Part Skew <sup>(2)</sup>	—	—	200	—	—	200	—	—	200	ps	
$t_{JITTER}$	Cycle-to-Cycle Jitter (rms)	—	0.2	< 1	—	0.2	< 1	—	0.2	< 1	ps <sub>RMS</sub>	
	Random Jitter	—	—	—	—	<1	—	—	—	—	ps <sub>RMS</sub>	<b>Note 3</b>
	Deterministic Jitter @ 1.25Gbps @ 2.5Gbps	—	—	—	—	<25 <50	—	—	—	—	ps <sub>PP</sub>	<b>Note 4</b>
$V_{DIFF}$	Input Voltage (Differential)	150	800	1200	150	800	1200	150	800	1200	mV	
$t_r$ , $t_f$	Output Rise/Fall Time Q, /Q (20% to 80%)	—	120	170	—	140	200	—	150	220	ps	

**Notes:**

- Measured with 750mV input signal, 50% duty cycle. Output swing  $\geq 400mV$ . All loading with a 50Ω to  $V_{CC} - 2.0V$ .
- Skew is measured between outputs under identical transitions. Duty cycle skew is defined only for differential operation when the delays are measured from the cross point of the inputs to the cross point of the outputs.
- RJ is measured with a K28.7 comma detect character pattern, measured at 1.25Gbps and 2.5Gbps.
- DJ is measured at 1.25Gbps and 2.5Gbps, with both K28.5 and 2<sup>23</sup>-1 PRBS pattern.

**TYPICAL OPERATING CHARACTERISTICS**

V<sub>CC</sub> = 3.3V, V<sub>EE</sub> = GND, T<sub>A</sub> = 25°C, unless otherwise stated.

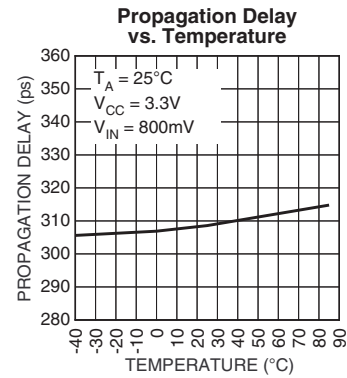
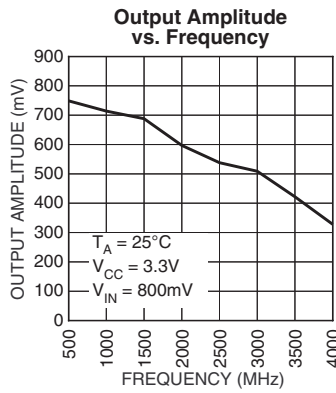

**500MHz Output**

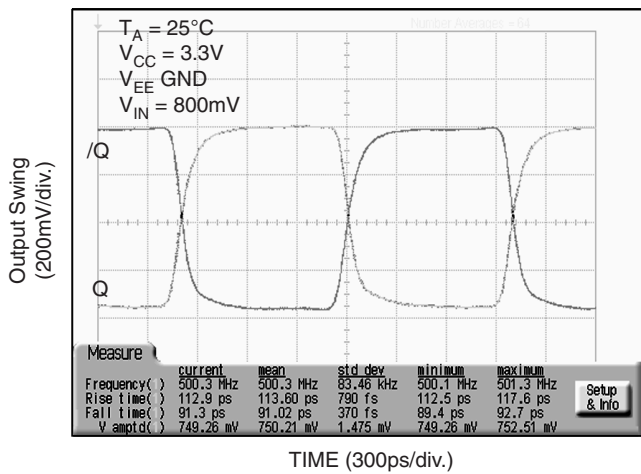

TIME (300ps/div.)

**1.5GHz Output**

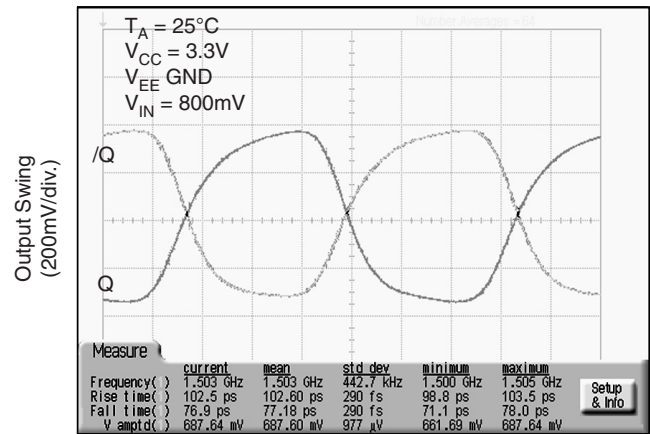

TIME (100ps/div.)

**2.5GHz Output**

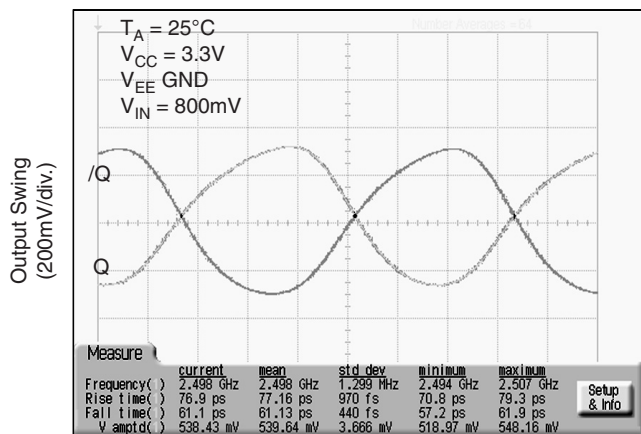

TIME (60ps/div.)

**3.0GHz Output**

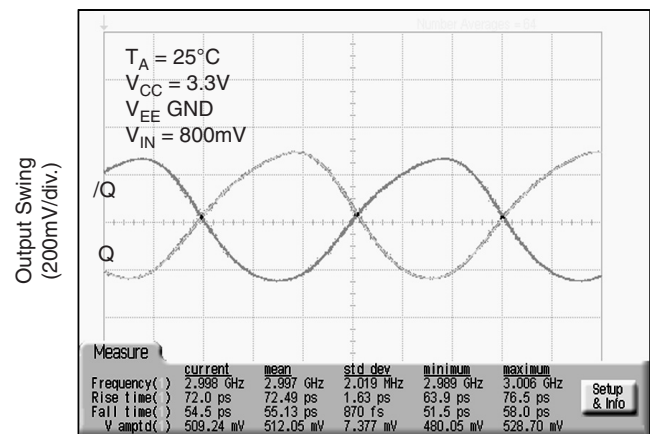

TIME (55ps/div.)

**TERMINATION RECOMMENDATIONS**

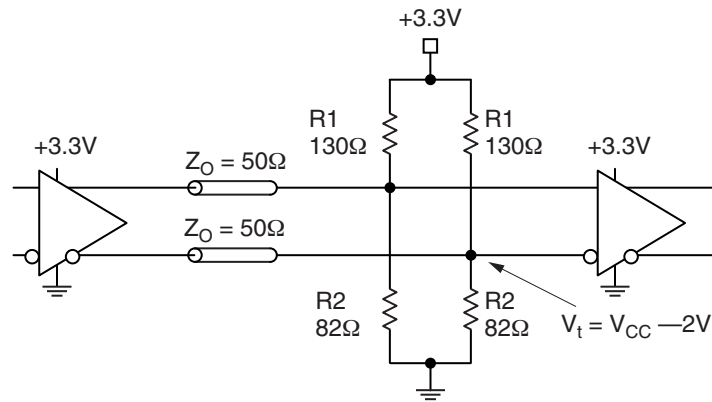

**Figure 1. Parallel Termination–Thevenin Equivalent**

**Note:**

- 1. For +5.0V systems: R1 = 82Ω, R2 = 130Ω.

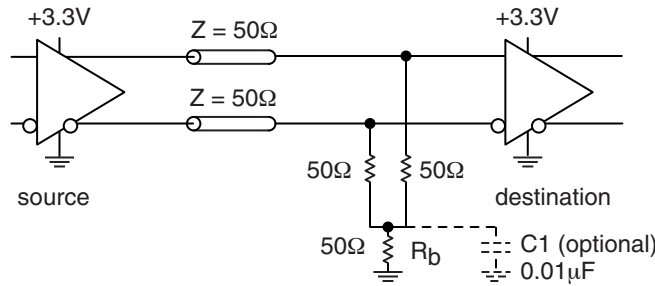

**Figure 2. Three-Resistor “Y-Termination”**

**Notes:**

- 1. Power-saving alternative to Thevenin termination.
- 2. Place termination resistors as close to destination inputs as possible.
- 3. R<sub>b</sub> resistor sets the DC bias voltage, equal to V<sub>t</sub>. For +3.3V systems R<sub>b</sub> = 46Ω to 50Ω. For +5V systems, R<sub>b</sub> = 110Ω.

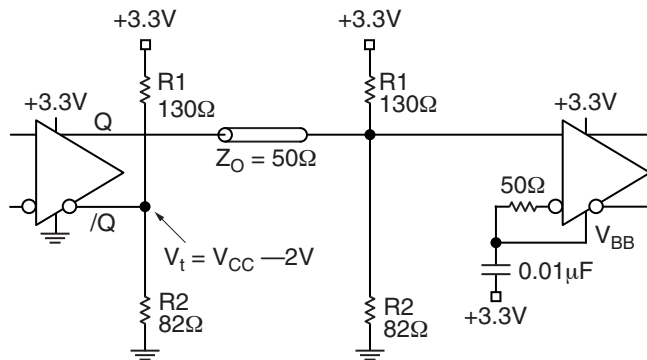
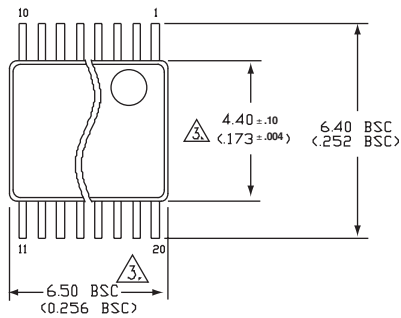

**Figure 3. Terminating Unused I/O**

**Notes:**

- 1. Unused output (/Q) must be terminated to balance the output.
- 2. Micrel's differential I/O logic devices include a V<sub>BB</sub> reference pin .
- 3. Connect unused input through 50Ω to V<sub>BB</sub>. Bypass with a 0.01μF capacitor to V<sub>CC</sub>, not GND.
- 4. For +2.5V systems: R1 = 250Ω, R2 = 62.5Ω.

**20-PIN TSSOP (K4-20-1)**



TOP VIEW

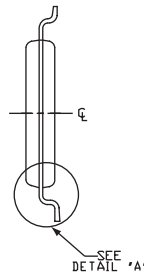

END VIEW

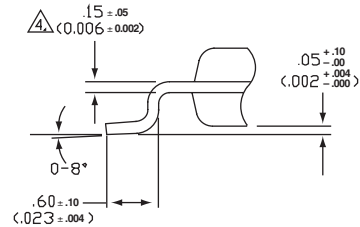

DETAIL 'A'  
(VIEW ROTATED 90° C.W.)

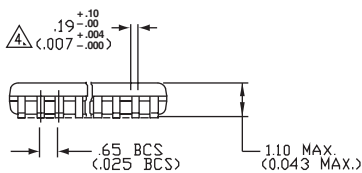

SIDE VIEW

- NOTES:
1. DIMENSIONS ARE IN MM(INCHES).
  2. CONTROLLING DIMENSION: MM.
  3. DIMENSION DOES NOT INCLUDE MOLD FLASH OF 0.254[0.010] MAX.
  4. THIS DIMENSION INCLUDES LEAD FINISH.

Rev.01

**MICREL, INC. 2180 FORTUNE DRIVE SAN JOSE, CA 95131 USA**

TEL + 1 (408) 944-0800 FAX + 1 (408) 474-1000 WEB <http://www.micrel.com>



The information furnished by Micrel in this datasheet is believed to be accurate and reliable. However, no responsibility is assumed by Micrel for its use. Micrel reserves the right to change circuitry and specifications at any time without notification to the customer.

Micrel Products are not designed or authorized for use as components in life support appliances, devices or systems where malfunction of a product can reasonably be expected to result in personal injury. Life support devices or systems are devices or systems that (a) are intended for surgical implant into the body or (b) support or sustain life, and whose failure to perform can be reasonably expected to result in a significant injury to the user. A Purchaser's use or sale of Micrel Products for use in life support appliances, devices or systems is at Purchaser's own risk and Purchaser agrees to fully indemnify Micrel for any damages resulting from such use or sale.

© 2005 Micrel, Incorporated.

## Looking for pricing, stock, or lifecycle information?

Click below to explore more details on WIN SOURCE:

-  [View SY100EP57VK4G-TR on WIN SOURCE](#)
-  [Microchip Technology](#) Information

## Optimize Your Supply Chain with WIN SOURCE Solutions

-  Global Sourcing Solution
-  Obsolete Management
-  Cost Control Management
-  Shortage Management
-  Alternative Solution
-  Excess Inventory Management