



**THE DATASHEET OF  
HV9861ANG-G**



---

---

## LED Driver with Average-Mode Constant Current Control

---

---

### Features

- Fast average current control
- Programmable constant off-time switching
- PWM / linear dimming input
- Output short circuit protection with skip mode
- Ambient operating temperature -40°C to +125°C
- Pin-compatible with the HV9910B and HV9961

### Applications

- DC/DC or AC/DC LED driver applications
- LED back-light driver for LCD displays
- General purpose constant current source
- LED signage and displays
- Architectural and decorative LED lighting
- LED street lighting

### Description

HV9861A is a patented, average-mode, constant-current control, LED driver IC operating in a constant off-time mode. Unlike the HV9910B, this control IC does not produce a peak-to-average error, which therefore greatly improves the accuracy, line and load regulation of the LED current without any need for loop compensation or high-side current sensing. The output LED current accuracy is  $\pm 3\%$ .

The IC is equipped with a current limit comparator for hiccup-mode output short circuit protection. Internal over-temperature protection is provided. The internally regulated voltage ( $V_{DD}$ ) for the HV9861A is 7.5V.

The IC can be powered from a 15 - 450V supply. A PWM dimming input is provided that accepts an external control TTL-compatible signal. The output current can be programmed by an internal 270mV reference, or controlled externally through a 0 - 1.5V dimming input.

HV9861A is pin-to-pin compatible with the HV9910B and HV9961, and can be used as a drop-in replacement for many applications to improve the LED current accuracy and regulation.

# HV9861A

## Package Types

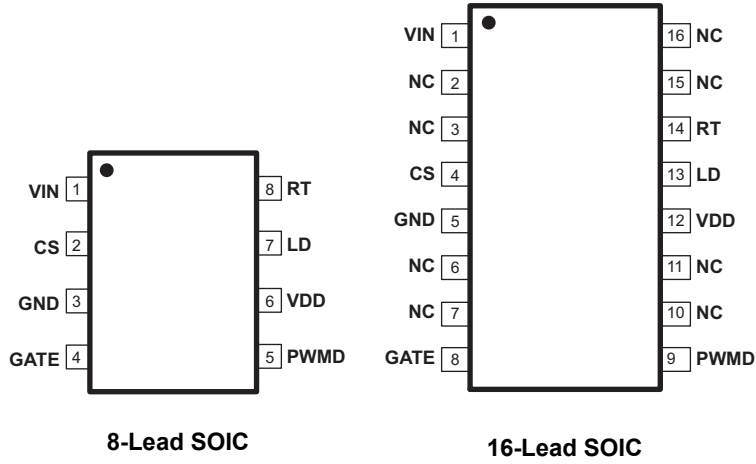

See [Table 2-1](#) for pin information

## Typical Application Circuit

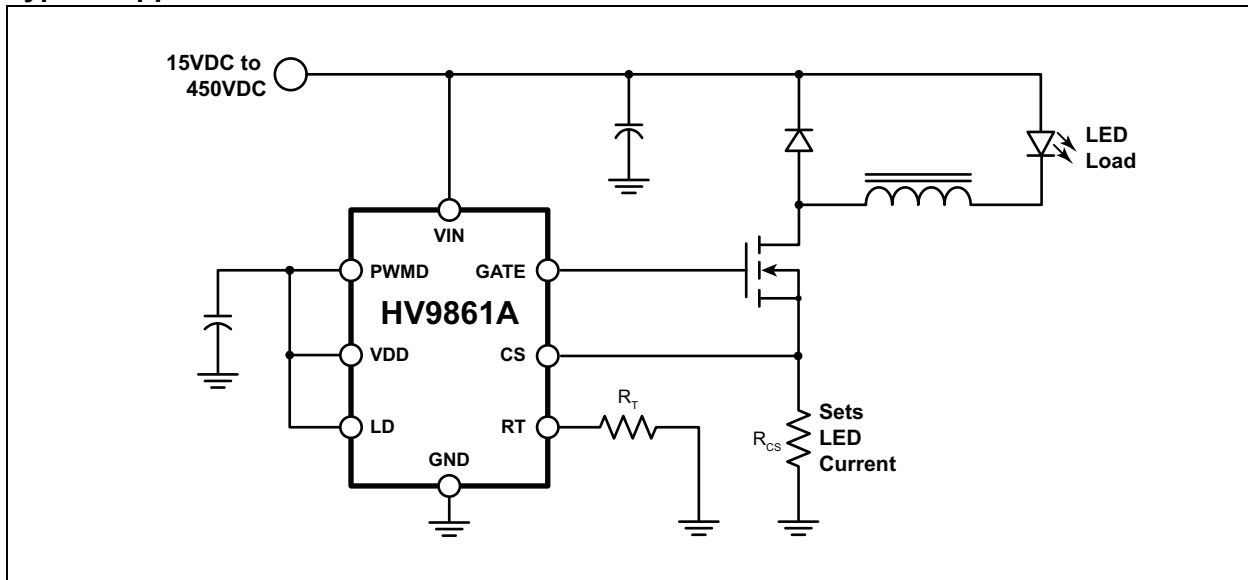

## 1.0 ELECTRICAL CHARACTERISTICS

### ABSOLUTE MAXIMUM RATINGS

$V_{IN}$ to GND.....	-0.5V to +470V
$V_{DD}$ to GND.....	12V
LD, PWM, GATE to GND.....	-0.3V to ( $V_{DD} + 0.3V$ )
CS, RT to GND .....	-0.3V to 5.0V
Operating temperature.....	-40°C to +125°C
Storage temperature .....	-65°C to +150°C
Continuous power dissipation ( $T_A = +25^\circ\text{C}$ )	
8-lead SOIC .....	650 mW
16-lead SOIC .....	1000 mW

**Note:** Stresses above those listed under “Absolute Maximum Ratings” may cause permanent damage to the device. This is a stress rating only and functional operation of the device at those or any other conditions, above those indicated in the operational listings of this specification, is not implied. Exposure to maximum rating conditions for extended periods may affect device reliability.

### 1.1 ELECTRICAL SPECIFICATIONS

**TABLE 1-1: ELECTRICAL CHARACTERISTICS (SHEET 1 OF 2)<sup>1</sup>**

Symbol	Parameter	Note	Min	Typ	Max	Units	Conditions
<b>Input</b>							
$V_{INDC}$	Input DC supply voltage range <sup>2</sup>	3	15	-	450	V	DC input voltage
$I_{INSD}$	Shut-down mode supply current	3	-	0.5	1.1	mA	Pin PWM to GND
<b>Internal Regulator</b>							
$V_{DD}$	Internally regulated voltage	-	7.25	7.50	8.20	V	500pF at GATE; RT = 226k $\Omega$
$\Delta V_{DD, \text{line}}$	Line regulation of $V_{DD}$	-	-	-	1	V	$V_{IN} = 15 - 450V$ , 500pF at GATE; RT = 226k $\Omega$
$\Delta V_{DD, \text{load}}$	Load regulation of $V_{DD}$	-	-	-	100	mV	$I_{DD(\text{ext})} = 0 - 1mA$ , 500pF at GATE; RT = 226k $\Omega$
UVLO	$V_{DD}$ under-voltage lockout threshold	3	6.45	-	-	V	$V_{IN}$ rising
$\Delta UVLO$	$V_{DD}$ under-voltage lockout hysteresis	-	-	500	-	mV	$V_{IN}$ falling
$\Delta V_{DD(UV)}$	$V_{DD}$ voltage margin	3	500	-	-	mV	$\Delta V_{DD(UV)} = V_{DD} - UVLO$
$I_{IN,MAX}$	Maximum input current (limited by UVLO)	4	3.5	-	-	mA	$V_{IN} = 15V, T_A = 25^\circ\text{C}$
		4	1.5	-	-		$V_{IN} = 15V, T_A = 125^\circ\text{C}$
<b>PWM Dimming</b>							
$V_{EN(lo)}$	PWM input low voltage	3	-	-	0.8	V	$V_{IN} = 15 - 450V$
$V_{EN(hi)}$	PWM input high voltage	3	2.2	-	-	V	$V_{IN} = 15 - 450V$
$I_{EN}$	Internal pull-down current at PWM	-	8.5	-	13.5	$\mu\text{A}$	$V_{PWM} = 0.8V$

# HV9861A

**TABLE 1-1: ELECTRICAL CHARACTERISTICS (CONTINUED) (SHEET 2 OF 2)<sup>1</sup>**

Symbol	Parameter	Note	Min	Typ	Max	Units	Conditions
<b>Average Current Sense Logic</b>							
$V_{CS}$	Current sense reference voltage	-	262	-	280	mV	
$A_{V(LD)}$	LD-to-CS voltage ratio	-	0.175	-	0.182	-	
$A_V \cdot V_{LD(OFFSET)}$	LD-to-CS voltage offset	-	-10	-	10	mV	Offset = $V_{CS} - (A_{V(LD)} \cdot V_{LD})$ ; $V_{LD} = 1.2V$
$\Delta V_{CS(TEMP)}$	CS threshold temp regulation	4	-	-	5	mV	
$V_{LD(OFF)}$	LD input voltage, shutdown	-	-	150	-	mV	$V_{LD}$ falling
$\Delta V_{LD(OFF)}$	LD input voltage, enable	-	-	200	-	mV	$V_{LD}$ rising
$T_{BLANK}$	Current sense blanking interval	3	140	-	290	ns	
$T_{ON(min)}$	Minimum on-time	-	-	-	760	ns	$CS = V_{CS} + 30mV$
$D_{MAX}$	Maximum steady-state duty cycle	3	80	-	-	%	Reduction in output LED current may occur beyond this duty cycle
<b>Short Circuit Protection</b>							
$V_{CS}$	Hiccup threshold voltage	3	410	-	510	mV	
$T_{DELAY}$	Current limit delay CS-to-GATE	-	-	-	150	ns	$CS = V_{CS} + 30mV$
$T_{HICCUP}$	Short circuit hiccup time	-	400	-	850	$\mu s$	
$T_{ON(min)}$	Minimum on-time (short circuit)	-	-	-	430	ns	$CS = 4V$
<b>TOFF Timer</b>							
$T_{OFF}$	Off-time	-	32	40	48	$\mu s$	$R_T = 1M\Omega$
		-	8	10	12		$R_T = 226k\Omega$
<b>GATE Driver</b>							
$I_{SOURCE}$	Sourcing current	-	0.165	-	-	A	$V_{GATE} = 0V, V_{DD} = 7.5V$
$I_{SINK}$	Sinking current	-	0.165	-	-	A	$V_{GATE} = V_{DD}, V_{DD} = 7.5V$
$t_{RISE}$	Output rise time	-	-	30	50	ns	$C_{GATE} = 500pF, V_{DD} = 7.5V$
$t_{FALL}$	Output fall time	-	-	30	50	ns	$C_{GATE} = 500pF, V_{DD} = 7.5V$
<b>Over-Temperature Protection</b>							
$T_{SD}$	Shut-down temperature	4	128	140	-	$^{\circ}C$	---
$\Delta T_{SD}$	Hysteresis	4	-	20	-	$^{\circ}C$	---

- Specifications are  $T_A = 25^{\circ}C$ ,  $V_{IN} = 15V$ ,  $V_{LD} = V_{DD}$ ,  $PWMD = V_{DD}$  unless otherwise noted.
- Also limited by package-power dissipation limit; Whichever is lower.
- Applies over the full operating ambient temperature range of  $-40^{\circ}C < T_A < +125^{\circ}C$ .
- For design guidance only

**TABLE 1-2: THERMAL RESISTANCE**

Package	$\theta_{ja}$
8-Lead SOIC	101 $^{\circ}C/W$
16-Lead SOIC	83 $^{\circ}C/W$

## 2.0 PIN DESCRIPTION

The locations of the pins are listed in [Package Types](#).

**TABLE 2-1: PIN DESCRIPTION**

Pin #		Function	Description
8-Lead SOIC	16-Lead SOIC		
1	1	VIN	Input of a 15 - 450V linear regulator.
2	4	CS	Current sense pin used to sense the FET current by means of an external sense resistor.
3	5	GND	Ground return for all internal circuitry. This pin must be electrically connected to the ground of the power train.
4	8	GATE	Output GATE driver for an external N-channel power MOSFET.
5	9	PWMD	PWM-dimming input of the IC. When this pin is pulled to GND, the gate driver is turned off. When the pin is pulled high, the gate driver operates normally.
6	12	VDD	Power supply pin for all internal circuits. It must be bypassed with a low ESR capacitor to GND (at least 0.1 $\mu$ F).
7	13	LD	Linear-dimming input. Sets the current sense threshold as long as the voltage at this pin is less than 1.5V. If voltage at LD falls below 150mV, the GATE output is disabled. The GATE signal recovers at 200mV at LD.
8	14	RT	A resistor connected between this pin and GND programs the GATE off-time.
-	2, 3, 6, 7, 10, 11, 15, 16	NC	No connection.

# HV9861A

## 3.0 APPLICATION INFORMATION

Peak-current control (as in the HV9910B) of a buck converter is the most economical and simple way to regulate its output current. However, this method suffers accuracy and regulation problems that arise from the so-called peak-to-average current error, contributed to by the current ripple in the output inductor and the propagation delay in the current-sense comparator. The full inductor-current signal is unavailable for direct sensing at the ground potential in a buck converter when the control switch is referenced to the same ground potential. While it is very simple to detect the peak current in the switch, controlling the average inductor current is usually implemented by level translating the sense signal from the positive supply rail. Though this is practical for relatively low input voltage, this type of average-current control may become excessively complex and expensive in off line AC or other high-voltage DC applications.

HV9861A employs a patented control scheme, achieving fast and very accurate control of average current in the buck inductor through sensing the switch current only. No compensation of the current-control loop is required. The LED current response to PWM input is similar to that of the HV9910B. The inductor-current ripple amplitude does not affect this control scheme significantly. Therefore, the LED current is independent of the variation in inductance, switching frequency, or output voltage. Constant off-time control of the buck converter is used for stability and to improve the LED-current regulation over a wide range of input voltages. (Note that, unlike the HV9910B, this IC does not support the constant-frequency mode of operation.)

### 3.1 OFF Timer

The timing resistor connected to RT determines the off-time of the gate driver, and it must be wired to GND. Wiring this resistor to GATE as with the HV9910B is no longer supported. The equation governing the off-time of the GATE output is given by:

$$T_{OFF}(\mu\text{S}) = \frac{R_T(\text{k}\Omega)}{25} + 0.3$$

Within the range of  $30\text{k}\Omega \leq R_T \leq 1.0\text{M}\Omega$ .

### 3.2 Average Current Control Feedback and Output Short Circuit Protection

The current through the switching MOSFET source is averaged and used to give constant-current feedback. This current is detected using a sense resistor at the

CS pin. The feedback operates in a fast open-loop mode. No compensation is required. Output current is programmed simply as:

$$I_{LED} = \frac{0.27\text{V}}{R_{CS}}$$

When the voltage at the LD input  $V_{LD} \geq 1.5\text{V}$ . Otherwise:

$$I_{LED} = \frac{V_{LD} \cdot 0.18}{R_{CS}}$$

The above equations are only valid for continuous conduction of the output inductor. It is a good practice to design the inductor such that the switching ripple current in it is 30~40% of its average peak-to-peak, full load, DC current. Hence, the recommended inductance can be calculated as:

$$L = \frac{V_{O(\text{MAX})} \cdot T_{OFF}}{0.4 \cdot I_O}$$

The duty-cycle range of the current control feedback is limited to  $D \leq 0.8$ . A reduction in the LED current may occur when the LED string voltage  $V_O$  is greater than 80% of the input voltage  $V_{IN}$  of the HV9861A LED driver.

Reducing the output LED voltage  $V_O$  below  $V_{O(\text{MIN})} = V_{IN} \cdot D_{\text{MIN}}$ , where  $D_{\text{MIN}} = 760\text{ns}/(T_{OFF} + 760\text{ns})$ , may also result in the loss of regulation of the LED current. However, this condition causes an increase in the LED current and can potentially trip the short-circuit protection comparator.

A typical output characteristic of the HV9861A LED driver is shown in Figure 3-1. The corresponding HV9910B characteristic is given for comparison.

**FIGURE 3-1: TYPICAL OUTPUT CHARACTERISTIC OF AN HV9861A LED DRIVER**

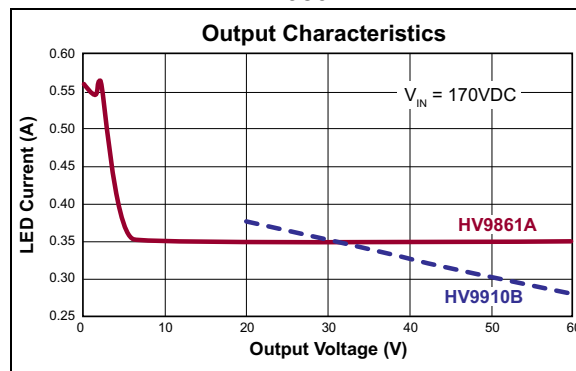

The short circuit protection comparator trips when the voltage at CS exceeds 0.45V. When this occurs, the GATE off-time  $T_{\text{HICCUP}} = 650\mu\text{s}$  is generated to prevent stair-casing of the inductor current, and potentially its saturation, due to insufficient output voltage. The typical short-circuit current is shown in the waveform of Figure 3-2.

**FIGURE 3-2: SHORT-CIRCUIT INDUCTOR CURRENT**

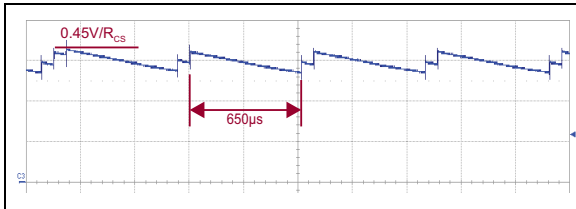

A leading-edge blanking delay is provided at CS to prevent false triggering of the current feedback and the short circuit protection.

### 3.3 Linear Dimming

When the voltage at LD falls below 1.5V, the internal 270mV reference to the constant-current feedback becomes overridden by  $V_{\text{LD}} \cdot 0.18$ . As long as the current in the inductor remains continuous, the LED current is given by the equation in Section 3.2. However, when  $V_{\text{LD}}$  falls below 150mV, the GATE output becomes disabled. The GATE signal recovers, when  $V_{\text{LD}}$  exceeds 200mV. This is required in some applications to be able to shut the LED lamp off with the same signal input that controls the brightness. The typical linear dimming response is shown in Figure 3-3.

**FIGURE 3-3: TYPICAL LINEAR DIMMING RESPONSE OF AN HV9861A LED DRIVER**

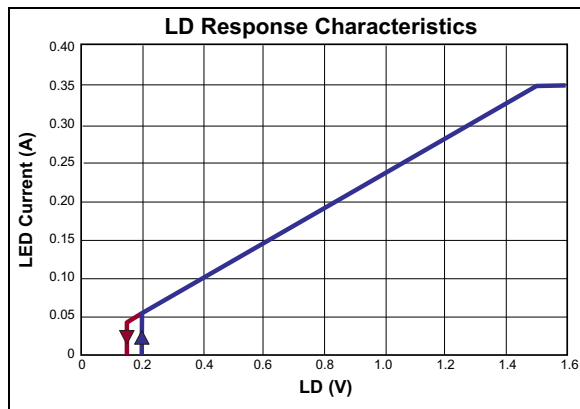

The linear dimming input could also be used for “mixed-mode” dimming to expand the dimming ratio. In such case a pulse-width modulated signal of a measured amplitude below 1.5V should be applied at LD.

### 3.4 Input Voltage Regulator

HV9861A can be powered directly from a 15 – 450VDC supply through its VIN input. When this voltage is applied at the VIN pin, the HV9861A maintains a constant 7.5V level at VDD. This voltage can be used to power the IC and external circuitry connected to VDD within the rated maximum current or within the thermal ratings of the package, whichever limit is lower. The VDD pin must be bypassed by a low ESR capacitor to provide a low impedance path for the high frequency current of the GATE output. The HV9861A can also be powered through the VDD pin directly with a voltage greater than the internally regulated 7.5V, but less than 12V.

Despite the instantaneous voltage rating of 450V, continuous voltage at VIN is limited by the power dissipation in the package. For example, when these ICs draw  $I_{\text{IN}} = 3.0\text{mA}$  from the VIN input, and the 8-lead SOIC package is used, the maximum continuous voltage at VIN is limited to the following:

$$V_{\text{IN(MAX)}} = \frac{T_{\text{J(MAX)}} - T_{\text{A}}}{R_{\theta, \text{J-A}} \cdot I_{\text{IN}}} = 330\text{V}$$

In this instance, the ambient temperature  $T_{\text{A}} = 25^{\circ}\text{C}$ , the maximum working junction temperature  $T_{\text{J(MAX)}} = 125^{\circ}\text{C}$ , and the junction-to-ambient thermal resistance  $R_{\theta, \text{JA}} = 101^{\circ}\text{C/W}$ .

In such cases, when it is needed to operate the HV9861A from a higher voltage, a resistor or a Zener diode can be added in series with the VIN input to divert some of the power loss from the IC. In the above example, using a 100V Zener diode will allow the circuit to work up to 430V. The input current drawn from the VIN pin is represented by the following equation:

$$I_{\text{IN}} \approx 1.0\text{mA} + Q_{\text{G}} \cdot f_{\text{S}}$$

In the above equation,  $f_{\text{S}}$  is the switching frequency, and  $Q_{\text{G}}$  is the GATE charge of the external FET obtained from the manufacturer’s data sheet.

### 3.5 GATE Output

The GATE output of HV9861A is used to drive an external MOSFET. The gate charge,  $Q_{\text{G}}$ , of the external MOSFET should be less than 25nC for switching frequencies  $\leq 100\text{kHz}$  and less than 15nC for switching frequencies  $> 100\text{kHz}$ .

# HV9861A

## 3.6 PWM Dimming

Due to the fast open-loop response of the average-mode, current-control loop of the HV9861A, the PWM dimming performance nearly matches that of the HV9910B. The inductor current waveform comparison is shown in Figure 3-4.

The rising and falling edges are limited by the current slew rate in the inductor. The first switching cycle is terminated upon reaching the 270mV ( $V_{LD} \cdot 0.18$ ) level at CS. The circuit is further reaching its steady-state within 3–4 switching cycles regardless of the switching frequency.

**FIGURE 3-4: TYPICAL PWM DIMMING RESPONSE OF AN HV9861A LED DRIVER**

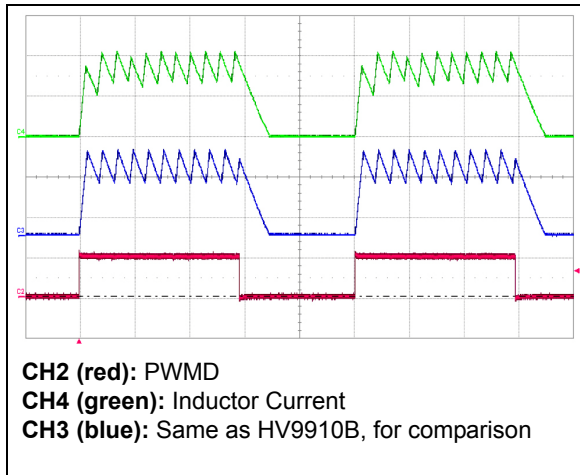

**FIGURE 3-5: FUNCTIONAL BLOCK DIAGRAM**

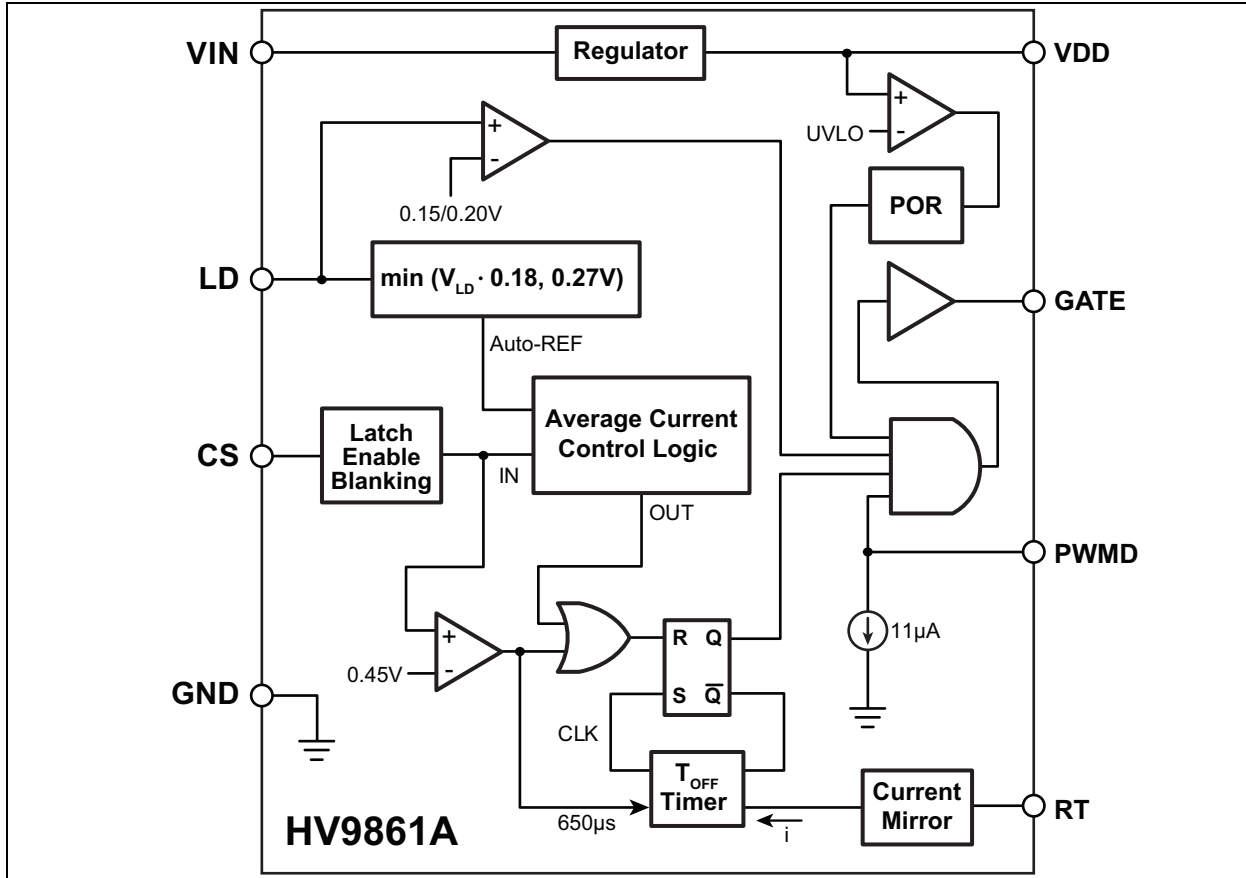

## 4.0 PACKAGING INFORMATION

### 4.1 Package Marking Information

8-lead SOIC

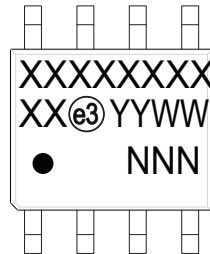

Example

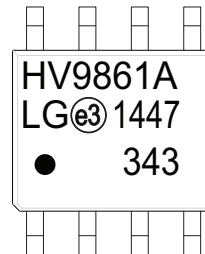

16-lead SOIC

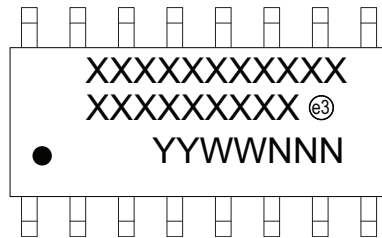

Example

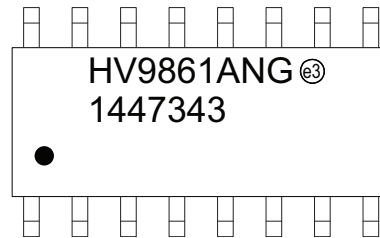

<b>Legend:</b>	XX...X	Product Code or Customer-specific information
	Y	Year code (last digit of calendar year)
	YY	Year code (last 2 digits of calendar year)
	WW	Week code (week of January 1 is week '01')
	NNN	Alphanumeric traceability code
		Pb-free JEDEC <sup>®</sup> designator for Matte Tin (Sn)
	*	This package is Pb-free. The Pb-free JEDEC designator ( ) can be found on the outer packaging for this package.

**Note:** In the event the full Microchip part number cannot be marked on one line, it will be carried over to the next line, thus limiting the number of available characters for product code or customer-specific information. Package may or not include the corporate logo.

# HV9861A

## 8-Lead SOIC (Narrow Body) Package Outline (LG/TG) 4.90x3.90mm body, 1.75mm height (max), 1.27mm pitch

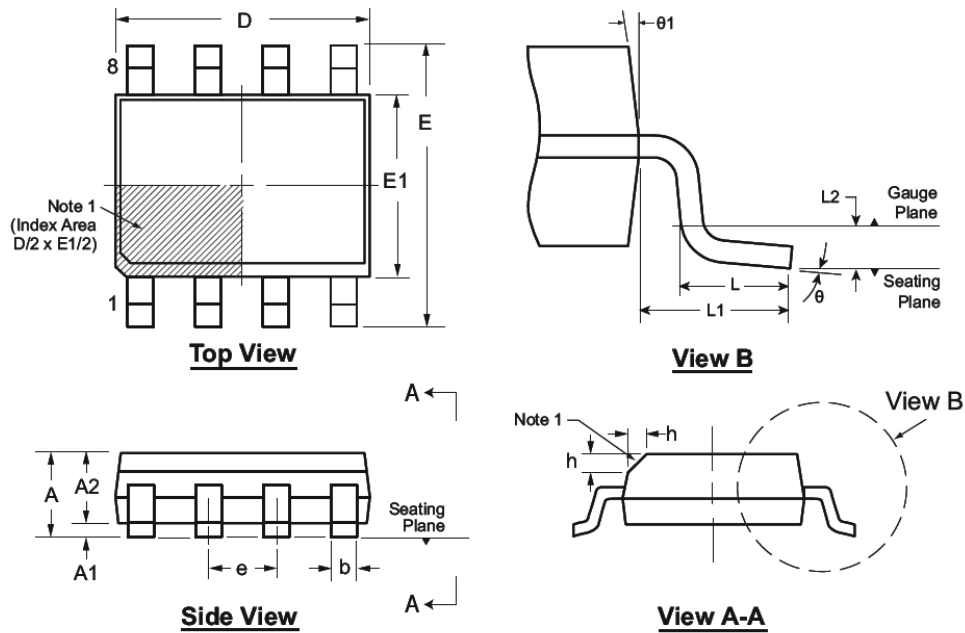

Note: For the most current package drawings, see the Microchip Packaging Specification at [www.microchip.com/packaging](http://www.microchip.com/packaging).

**Note:**

1. This chamfer feature is optional. A Pin 1 identifier must be located in the index area indicated. The Pin 1 identifier can be: a molded mark/identifier, an embedded metal marker, or a printed indicator.

Symbol	A	A1	A2	b	D	E	E1	e	h	L	L1	L2	$\theta$	$\theta_1$		
Dimension (mm)	MIN	1.35*	0.10	1.25	0.31	4.80*	5.80*	3.80*	1.27 BSC	0.25	0.40	1.04 REF	0.25 BSC	0°	5°	
	NOM	-	-	-	-	4.90	6.00	3.90		-	-		-	-	-	-
	MAX	1.75	0.25	1.65*	0.51	5.00*	6.20*	4.00*		0.50	1.27		-	-	8°	15°

JEDEC Registration MS-012, Variation AA, Issue E, Sept. 2005.

\* This dimension is not specified in the JEDEC drawing.

Drawings are not to scale.

## 16-Lead SOIC (Narrow Body) Package Outline (NG) 9.90x3.90mm body, 1.75mm height (max), 1.27mm pitch

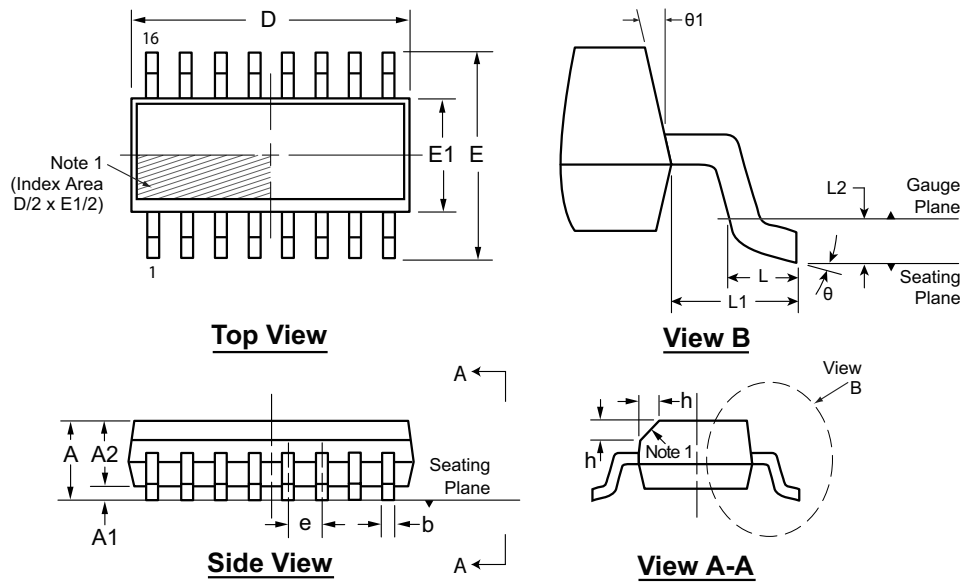

Note: For the most current package drawings, see the Microchip Packaging Specification at [www.microchip.com/packaging](http://www.microchip.com/packaging).

**Note:**

1. This chamfer feature is optional. If it is not present, then a Pin 1 identifier must be located in the index area indicated. The Pin 1 identifier can be: a molded mark/identifier; an embedded metal marker; or a printed indicator.

Symbol	A	A1	A2	b	D	E	E1	e	h	L	L1	L2	$\theta$	$\theta 1$	
Dimension (mm)	MIN	1.35*	0.10	1.25	0.31	9.80*	5.80*	3.80*	1.27 BSC	0.25	0.40	1.04 REF	0.25	8°	5°
	NOM	-	-	-	-	9.90	6.00	3.90		-	-		0.25 BSC		-
	MAX	1.75	0.25	1.65*	0.51	10.00*	6.20*	4.00*		0.50	1.27		15°		

JEDEC Registration MS-012, Variation AC, Issue E, Sept. 2005.

\* This dimension is not specified in the JEDEC drawing.

**Drawings are not to scale.**

# HV9861A

---

## APPENDIX A: REVISION HISTORY

### Revision A (December 2014)

- Original Release of this Document.

## PRODUCT IDENTIFICATION SYSTEM

To order or obtain information, e.g., on pricing or delivery, refer to the factory or the listed sales office.

<u>PART NO.</u>	<u>XX</u>	-	<u>X</u>	-	<u>X</u>
Device	Package Options		Environmental		Media Type
Device:	HV9861A= LED Driver with Average-Mode Constant Current Control				
Package:	LG = 8-lead SOIC NG = 16-lead SOIC				
Environmental	G = Lead (Pb)-free/ROHS-compliant package				
Media Type:	(blank) = Reel for LG package, Tube for NG package				

**Examples:**

a) HV9861ALG-G: 8-lead SOIC package, 2500/Reel.

b) HV9861ANG-G: 16-lead SOIC package, 45/Tube

---

---

**Note the following details of the code protection feature on Microchip devices:**

- Microchip products meet the specification contained in their particular Microchip Data Sheet.
- Microchip believes that its family of products is one of the most secure families of its kind on the market today, when used in the intended manner and under normal conditions.
- There are dishonest and possibly illegal methods used to breach the code protection feature. All of these methods, to our knowledge, require using the Microchip products in a manner outside the operating specifications contained in Microchip's Data Sheets. Most likely, the person doing so is engaged in theft of intellectual property.
- Microchip is willing to work with the customer who is concerned about the integrity of their code.
- Neither Microchip nor any other semiconductor manufacturer can guarantee the security of their code. Code protection does not mean that we are guaranteeing the product as “unbreakable.”

Code protection is constantly evolving. We at Microchip are committed to continuously improving the code protection features of our products. Attempts to break Microchip's code protection feature may be a violation of the Digital Millennium Copyright Act. If such acts allow unauthorized access to your software or other copyrighted work, you may have a right to sue for relief under that Act.

Information contained in this publication regarding device applications and the like is provided only for your convenience and may be superseded by updates. It is your responsibility to ensure that your application meets with your specifications. MICROCHIP MAKES NO REPRESENTATIONS OR WARRANTIES OF ANY KIND WHETHER EXPRESS OR IMPLIED, WRITTEN OR ORAL, STATUTORY OR OTHERWISE, RELATED TO THE INFORMATION, INCLUDING BUT NOT LIMITED TO ITS CONDITION, QUALITY, PERFORMANCE, MERCHANTABILITY OR FITNESS FOR PURPOSE. Microchip disclaims all liability arising from this information and its use. Use of Microchip devices in life support and/or safety applications is entirely at the buyer's risk, and the buyer agrees to defend, indemnify and hold harmless Microchip from any and all damages, claims, suits, or expenses resulting from such use. No licenses are conveyed, implicitly or otherwise, under any Microchip intellectual property rights.

#### **Trademarks**

The Microchip name and logo, the Microchip logo, dsPIC, FlashFlex, KEELOQ, KEELOQ logo, MPLAB, PIC, PICmicro, PICSTART, PIC<sup>32</sup> logo, rPIC, SST, SST Logo, SuperFlash and UNI/O are registered trademarks of Microchip Technology Incorporated in the U.S.A. and other countries.

FilterLab, Hampshire, HI-TECH C, Linear Active Thermistor, MTP, SEEVAL and The Embedded Control Solutions Company are registered trademarks of Microchip Technology Incorporated in the U.S.A.

Silicon Storage Technology is a registered trademark of Microchip Technology Inc. in other countries.

Analog-for-the-Digital Age, Application Maestro, BodyCom, chipKIT, chipKIT logo, CodeGuard, dsPICDEM, dsPICDEM.net, dsPICworks, dsSPEAK, ECAN, ECONOMONITOR, FanSense, HI-TIDE, In-Circuit Serial Programming, ICSP, Mindi, MiWi, MPASM, MPF, MPLAB Certified logo, MPLIB, MPLINK, mTouch, Omniclient Code Generation, PICC, PICC-18, PICDEM, PICDEM.net, PICkit, PICTail, REAL ICE, rFLAB, Select Mode, SQI, Serial Quad I/O, Total Endurance, TSHARC, UniWinDriver, WiperLock, ZENA and Z-Scale are trademarks of Microchip Technology Incorporated in the U.S.A. and other countries.

SQTP is a service mark of Microchip Technology Incorporated in the U.S.A.

GestIC and ULPP are registered trademarks of Microchip Technology Germany II GmbH & Co. KG, a subsidiary of Microchip Technology Inc., in other countries.

All other trademarks mentioned herein are property of their respective companies.

© 2014, Microchip Technology Incorporated, Printed in the U.S.A., All Rights Reserved.

 Printed on recycled paper.

ISBN: 978-1-63276-871-1

*Microchip received ISO/TS-16949:2009 certification for its worldwide headquarters, design and wafer fabrication facilities in Chandler and Tempe, Arizona; Gresham, Oregon and design centers in California and India. The Company's quality system processes and procedures are for its PIC<sup>®</sup> MCUs and dsPIC<sup>®</sup> DSCs, KEELOQ<sup>®</sup> code hopping devices, Serial EEPROMs, microperipherals, nonvolatile memory and analog products. In addition, Microchip's quality system for the design and manufacture of development systems is ISO 9001:2000 certified.*

**QUALITY MANAGEMENT SYSTEM  
CERTIFIED BY DNV  
= ISO/TS 16949 =**



# MICROCHIP

## Worldwide Sales and Service

### AMERICAS

**Corporate Office**  
2355 West Chandler Blvd.  
Chandler, AZ 85224-6199  
Tel: 480-792-7200  
Fax: 480-792-7277  
Technical Support:  
<http://www.microchip.com/support>  
Web Address:  
[www.microchip.com](http://www.microchip.com)

**Atlanta**  
Duluth, GA  
Tel: 678-957-9614  
Fax: 678-957-1455

**Austin, TX**  
Tel: 512-257-3370

**Boston**  
Westborough, MA  
Tel: 774-760-0087  
Fax: 774-760-0088

**Chicago**  
Itasca, IL  
Tel: 630-285-0071  
Fax: 630-285-0075

**Cleveland**  
Independence, OH  
Tel: 216-447-0464  
Fax: 216-447-0643

**Dallas**  
Addison, TX  
Tel: 972-818-7423  
Fax: 972-818-2924

**Detroit**  
Novi, MI  
Tel: 248-848-4000

**Houston, TX**  
Tel: 281-894-5983

**Indianapolis**  
Noblesville, IN  
Tel: 317-773-8323  
Fax: 317-773-5453

**Los Angeles**  
Mission Viejo, CA  
Tel: 949-462-9523  
Fax: 949-462-9608

**New York, NY**  
Tel: 631-435-6000

**San Jose, CA**  
Tel: 408-735-9110

**Canada - Toronto**  
Tel: 905-673-0699  
Fax: 905-673-6509

### ASIA/PACIFIC

**Asia Pacific Office**  
Suites 3707-14, 37th Floor  
Tower 6, The Gateway  
Harbour City, Kowloon  
Hong Kong  
Tel: 852-2943-5100  
Fax: 852-2401-3431

**Australia - Sydney**  
Tel: 61-2-9868-6733  
Fax: 61-2-9868-6755

**China - Beijing**  
Tel: 86-10-8569-7000  
Fax: 86-10-8528-2104

**China - Chengdu**  
Tel: 86-28-8665-5511  
Fax: 86-28-8665-7889

**China - Chongqing**  
Tel: 86-23-8980-9588  
Fax: 86-23-8980-9500

**China - Hangzhou**  
Tel: 86-571-8792-8115  
Fax: 86-571-8792-8116

**China - Hong Kong SAR**  
Tel: 852-2943-5100  
Fax: 852-2401-3431

**China - Nanjing**  
Tel: 86-25-8473-2460  
Fax: 86-25-8473-2470

**China - Qingdao**  
Tel: 86-532-8502-7355  
Fax: 86-532-8502-7205

**China - Shanghai**  
Tel: 86-21-5407-5533  
Fax: 86-21-5407-5066

**China - Shenyang**  
Tel: 86-24-2334-2829  
Fax: 86-24-2334-2393

**China - Shenzhen**  
Tel: 86-755-8864-2200  
Fax: 86-755-8203-1760

**China - Wuhan**  
Tel: 86-27-5980-5300  
Fax: 86-27-5980-5118

**China - Xian**  
Tel: 86-29-8833-7252  
Fax: 86-29-8833-7256

**China - Xiamen**  
Tel: 86-592-2388138  
Fax: 86-592-2388130

**China - Zhuhai**  
Tel: 86-756-3210040  
Fax: 86-756-3210049

### ASIA/PACIFIC

**India - Bangalore**  
Tel: 91-80-3090-4444  
Fax: 91-80-3090-4123

**India - New Delhi**  
Tel: 91-11-4160-8631  
Fax: 91-11-4160-8632

**India - Pune**  
Tel: 91-20-3019-1500

**Japan - Osaka**  
Tel: 81-6-6152-7160  
Fax: 81-6-6152-9310

**Japan - Tokyo**  
Tel: 81-3-6880-3770  
Fax: 81-3-6880-3771

**Korea - Daegu**  
Tel: 82-53-744-4301  
Fax: 82-53-744-4302

**Korea - Seoul**  
Tel: 82-2-554-7200  
Fax: 82-2-558-5932 or  
82-2-558-5934

**Malaysia - Kuala Lumpur**  
Tel: 60-3-6201-9857  
Fax: 60-3-6201-9859

**Malaysia - Penang**  
Tel: 60-4-227-8870  
Fax: 60-4-227-4068

**Philippines - Manila**  
Tel: 63-2-634-9065  
Fax: 63-2-634-9069

**Singapore**  
Tel: 65-6334-8870  
Fax: 65-6334-8850

**Taiwan - Hsin Chu**  
Tel: 886-3-5778-366  
Fax: 886-3-5770-955

**Taiwan - Kaohsiung**  
Tel: 886-7-213-7830

**Taiwan - Taipei**  
Tel: 886-2-2508-8600  
Fax: 886-2-2508-0102

**Thailand - Bangkok**  
Tel: 66-2-694-1351  
Fax: 66-2-694-1350

### EUROPE

**Austria - Wels**  
Tel: 43-7242-2244-39  
Fax: 43-7242-2244-393

**Denmark - Copenhagen**  
Tel: 45-4450-2828  
Fax: 45-4485-2829

**France - Paris**  
Tel: 33-1-69-53-63-20  
Fax: 33-1-69-30-90-79

**Germany - Dusseldorf**  
Tel: 49-2129-3766400

**Germany - Munich**  
Tel: 49-89-627-144-0  
Fax: 49-89-627-144-44

**Germany - Pforzheim**  
Tel: 49-7231-424750

**Italy - Milan**  
Tel: 39-0331-742611  
Fax: 39-0331-466781

**Italy - Venice**  
Tel: 39-049-7625286

**Netherlands - Drunen**  
Tel: 31-416-690399  
Fax: 31-416-690340

**Poland - Warsaw**  
Tel: 48-22-3325737

**Spain - Madrid**  
Tel: 34-91-708-08-90  
Fax: 34-91-708-08-91



**Sweden - Stockholm**  
Tel: 46-8-5090-4654

**UK - Wokingham**  
Tel: 44-118-921-5800  
Fax: 44-118-921-5820

03/25/14

## Looking for pricing, stock, or lifecycle information?

Click below to explore more details on WIN SOURCE:

-  [View HV9861ANG-G on WIN SOURCE](#)
-  [Microchip Technology](#) Information

## Optimize Your Supply Chain with WIN SOURCE Solutions

-  Global Sourcing Solution
-  Obsolete Management
-  Cost Control Management
-  Shortage Management
-  Alternative Solution
-  Excess Inventory Management