



**THE DATASHEET OF
MAX14536EEVB+T**





Low-Resistance DPDT Switches with Negative Rail

General Description

The MAX14535E–MAX14539E are low on-resistance and high ESD-protected DPDT switches that multiplex analog signals, such as AC-coupled audio or video. These devices combine the low on-capacitance (C_{ON}) and low on-resistance (R_{ON}) necessary for high-performance switching applications in portable electronics, and include an internal negative supply to pass audio signals that swing below ground (down to -1.5V).

The MAX14535E/MAX14537E/MAX14539E feature internal shunt resistors on the normally open path (and normally closed path, (MAX14539E)) to reduce clicks and pops heard at the output. The MAX14535E–MAX14539E have an enable input (EN) to reduce supply current and set all channels to high-impedance when driven low. When EN is driven low, the MAX14537E/MAX14538E have the lowest possible current consumption, but cannot withstand negative rail signals. The MAX14535E/MAX14536E/MAX14539E can still withstand a negative signal to NC₋, NO₋, or COM₋ from -1.5V to min (V_{CC} , 3V).

The MAX14535E–MAX14539E operate from a +2.4V to +5.5V supply. These devices can be powered from the typical analog supply voltage in a cell phone (+2.5V to +2.8V) or a lithium-ion (Li+) battery (about 4.3V max). The MAX14535E–MAX14539E have high ESD protection, up to $\pm 15kV$ on COM₋, and the NC₋, NO₋, and COM₋ voltage can go up to 3.6V when $V_{CC} = 0$ without damaging the devices.

All devices are offered in a space-saving, 10-pin, 1.4mm x 1.8mm UTQFN package, and operate over the -40°C to +85°C extended temperature range.

Applications

Cell Phones
MP3 Players

Notebook Computers
PDAs

Features

- ◆ Low 0.135 Ω (typ) On-Resistance
- ◆ Low 0.3m Ω (typ) R_{ON} Flatness
- ◆ Single +2.4V to +5.5V Supply Voltage
- ◆ Pass Audio Signal Between -1.5V and min (V_{CC} , 3V)
- ◆ Internal Shunt Resistors for Click-and-Pop Reduction (MAX14535E/MAX14537E/MAX14539E)
- ◆ Withstand 3.6V (max) Applied to NC₋, NO₋, and COM₋ when $V_{CC} = 0V$
- ◆ High ESD Protection: Up to $\pm 15kV$ on COM₋
- ◆ 10-Pin UTQFN (1.4mm x 1.8mm) Package
- ◆ -40°C to +85°C Operating Temperature Range

Pin Configuration

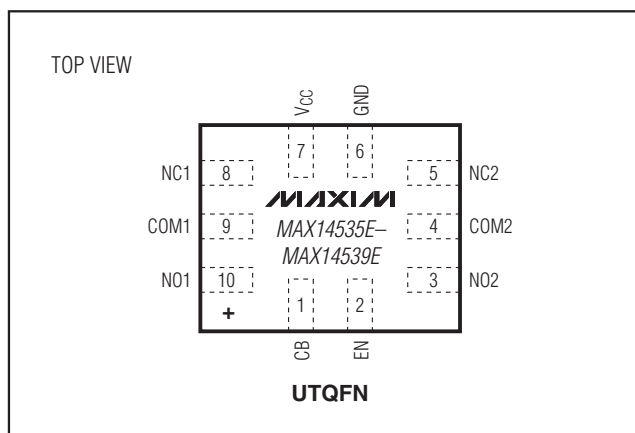

Typical Operating Circuits appear at end of data sheet.

Ordering Information/Selector Guide

PART	PIN-PACKAGE	TOP MARK	SHUNT RESISTORS	SHUTDOWN MODE (EN = LOW) SIGNAL RANGE
MAX14535EEVB+	10 UTQFN	AAS	NO1, NO2 Terminals	-1.5V to min (V_{CC} , 3V)
MAX14536EEVB+	10 UTQFN	AAT	—	-1.5V to min (V_{CC} , 3V)
MAX14537EEVB+*	10 UTQFN	AAU	NO1, NO2 Terminals	0 to V_{CC}
MAX14538EEVB+*	10 UTQFN	AAV	—	0 to V_{CC}
MAX14539EEVB+*	10 UTQFN	AAW	NO ₋ and NC ₋ Terminals	-1.5V to min (V_{CC} , 3V)

Note: All devices are specified over the -40°C to +85°C temperature range.

+Denotes a lead(Pb)-free package/RoHS-compliant package.

*Future product—contact factory for availability.



Low-Resistance DPDT Switches with Negative Rail

ABSOLUTE MAXIMUM RATINGS

(Voltages referenced to GND.)

V _{CC} , CB, EN	-0.3V to +6.0V
NO ₋ , NC ₋ , COM ₋ (V _{CC} > 2.4V, MAX14535E/ MAX14536E/MAX14539E)	-1.8V to +3.6V
NO ₋ , NC ₋ , COM ₋ (V _{CC} < 2.4V, MAX14535E/ MAX14536E/MAX14539E)	-0.3V to +3.6V
NO ₋ , NC ₋ , COM ₋ (V _{EN} < V _{IL} , MAX14537E/ MAX14538E)	-0.3V to +6.0V
NO ₋ , NC ₋ , COM ₋ (V _{EN} > V _{IL} , V _{CC} > 2.4V, MAX14537E/MAX14538E)	-1.8V to +3.6V
NO ₋ , NC ₋ , COM ₋ (V _{EN} < V _{IL} , V _{CC} < 2.4V, MAX14537E/MAX14538E)	-0.3V to +3.6V

Continuous Current into NO ₋ , NC ₋ , COM ₋ Terminals	±300mA
Peak Current into NO ₋ , NC ₋ , COM ₋ Terminals (50% duty cycle)	±500mA
Continuous Power Dissipation (T _A = +70°C)	
10-Pin UTQFN (derate 6.9mW/°C above +70°C)	559mW
Junction-to-Ambient Thermal Resistance (θ _{JA}) (Note 1)	143.1°C/W
Junction-to-Case Thermal Resistance (θ _{JC}) (Note 1)	20.1°C/W
Operating Temperature Range	-40°C to +85°C
Storage Temperature Range	-65°C to +150°C
Junction Temperature Range	-40°C to +150°C
Lead Temperature (soldering, 10s)	+300°C

Note 1: Package thermal resistances were obtained using the method described in JEDEC specification JESD51-7 using a four-layer board. For detailed information on package thermal considerations, refer to www.maxim-ic.com/thermal-tutorial.

Stresses beyond those listed under "Absolute Maximum Ratings" may cause permanent damage to the device. These are stress ratings only, and functional operation of the device at these or any other conditions beyond those indicated in the operational sections of the specifications is not implied. Exposure to absolute maximum rating conditions for extended periods may affect device reliability.

ELECTRICAL CHARACTERISTICS

(V_{CC} = +2.4V to +5.5V, T_A = -40°C to +85°C, unless otherwise noted. Typical values are at V_{CC} = +3.0V, T_A = +25°C.) (Note 2)

PARAMETER	SYMBOL	CONDITIONS	MIN	TYP	MAX	UNITS
Power-Supply Range	V _{CC}		2.4		5.5	V
Supply Current	I _{CC}	V _{CC} = 3.0V	MAX14537E/MAX14538E, V _{EN} = 0		1	μA
			MAX14535E/MAX14536E/ MAX14539E, V _{EN} = 0, V _{EN} = V _{CC}	8	15	
		V _{CC} = 5.5V	MAX14537E/MAX14538E, V _{EN} = 0		1	
			MAX14535E/MAX14536E/ MAX14539E, V _{EN} = 0, V _{EN} = V _{CC}	12	25	
Supply Current Increase with Logic Level		V _{EN} = 0.4V or 1.4V, V _{CB} = 0.4V or 1.4V			5	μA
Analog Signal Range		MAX14537E/MAX14538E, V _{EN} < V _{IL}	0		V _{CC}	V
		MAX14537E/MAX14538E, V _{EN} > V _{IH}	-1.5		Min (3.0V, V _{CC})	
		MAX14535E/MAX14536E/MAX14539E	-1.5		Min (3.0V, V _{CC})	
On-Resistance	R _{ON}	V _{CC} = 3.0V, V _{COM-} = -1.5V, 3.0V; I _{NO-} = 100mA or I _{NC-} = 100mA		0.135	0.35	Ω
On-Resistance Match Between Channels	ΔR _{ON}	V _{CC} = 3.0V, V _{COM-} = 0; I _{COM-} = 100mA (Note 3)			0.05	Ω
On-Resistance Flatness	R _{FLAT(ON)}	V _{CC} = 3.0V, I _{COM-} = 100mA; V _{COM-} = -1.5V to +3.0V (Note 4)		0.3	1	mΩ
Shunt Switch Resistance	R _{SH}	I _{NO-} or I _{NC-} = 1mA		500	1000	Ω

Low-Resistance DPDT Switches with Negative Rail

MAX14535E-MAX14539E

ELECTRICAL CHARACTERISTICS (continued)

(V_{CC} = +2.4V to +5.5V, T_A = -40°C to +85°C, unless otherwise noted. Typical values are at V_{CC} = +3.0V, T_A = +25°C.) (Note 2)

PARAMETER	SYMBOL	CONDITIONS	MIN	TYP	MAX	UNITS
NC_ or NO_ Off-Leakage Current	I _{NC_NO(OFF)}	Switch open, V _{EN} = V _{CC} , V _{NO_} or V _{NC_} = 0 or 2.5V, V _{COM_} = 0V or 2.5V	-10		+10	nA
COM_ Off-Leakage Current	I _{COM(OFF)}	V _{EN} = 0, V _{CC} = 3.0V, V _{COM_} = 3.0V, V _{NC_} = V _{NO_} = 0	-10		+10	nA
		V _{CC} = 0, V _{COM_} = 3.6V, V _{NC_} = V _{NO_} = unconnected	-1.5		+1.5	mA
COM_ On-Leakage Current	I _{COM(ON)}	V _{CC} = 3.0V, V _{COM_} = -1.5V or +2.5V, V _{NC_} or V _{NO_} = -1.5V, 2.5V or unconnected	-100		+100	nA
AC CHARACTERISTICS						
Turn-On Time	t _{ON}	V _{CC} = 3.0V, V _{NC_} or V _{NO_} = 1.5V, R _L = 50Ω, C _L = 100pF, (V _{EN} = 0 to V _{CC}) or (V _{EN} = V _{CC} and V _{CB} transitions), Figure 1		40	90	μs
Turn-Off Time	t _{OFF}	V _{CC} = 3.0V, V _{NC_} or V _{NO_} = 1.5V, R _L = 50Ω, C _L = 100pF, (V _{EN} = V _{CC} to 0) or (V _{EN} = V _{CC} and V _{CB} transitions), Figure 1		18	40	μs
Break-Before-Make Time Delay	t _D	V _{NC_} = V _{NO_} = 1.5V, R _L = 50Ω, Figure 2		28		μs
Off-Isolation	V _{ISO}	f = 100kHz, V _{COM_} = 0dBm, R _L = 50Ω, Figure 3		-70		dB
Crosstalk	V _{CT}	f = 100kHz, V _{COM_} = 0dBm, R _L = 50Ω, Figure 3 (Note 5)		-80		dB
NC_ -3dB Bandwidth	BW _{NC_}	R _S = R _L = 50Ω, V _{NO_} = 0dBm, Figure 3a-3d		100		MHz
NO_ -3dB Bandwidth	BW _{NO_}	R _S = R _L = 50Ω, V _{NO_} = 0dBm, Figure 3a-3d		100		MHz
Power-Supply Rejection Ratio	PSRR	f = 10kHz, V _{CC} = 3V ± 0.3V, R _{COM_} = 50Ω		90		dB
Total Harmonic Distortion	THD	f = 20Hz to 20kHz, V _{COM_} = 0.5VP-P, DC bias = 0, R _L = 32Ω		0.003		%
COM_ On-Capacitance	C _{COM(ON)}	f = 1MHz, V _{COM_} = 0.5VP-P, DC bias = 0		15		pF
NC_, NO_ Off-Capacitance	C _{NC_NO(OFF)}	f = 1MHz, V _{COM_} = 0.5VP-P, DC bias = 0		30		pF
LOGIC INPUT						
Input Logic-High	V _{IH}		1.4			V
Input Logic-Low	V _{IL}				0.4	V
Input Leakage Current	I _{IN}	V _{CB} = 0 or V _{CC} , V _{EN} = 0V or V _{CC}	-1		+1	μA
ESD PROTECTION						
COM1, COM2		Human Body Model		±15		kV
		IEC 61000 Air-Gap Discharge		±15		
		IEC 61000 Contact Discharge		±8		
All Pins		Human Body Model		±2		kV

Note 2: Devices are production tested at T_A = +25°C. Specifications over temperature limits are guaranteed by design.

Note 3: ΔR_{ON(MAX)} = |R_{ON(CH1)} - R_{ON(CH2)}|

Note 4: Flatness is defined as the difference between the maximum and minimum value of on-resistance, as measured over specified analog signal ranges. These values are guaranteed by design.

Note 5: Between two switches.

Low-Resistance DPDT Switches with Negative Rail

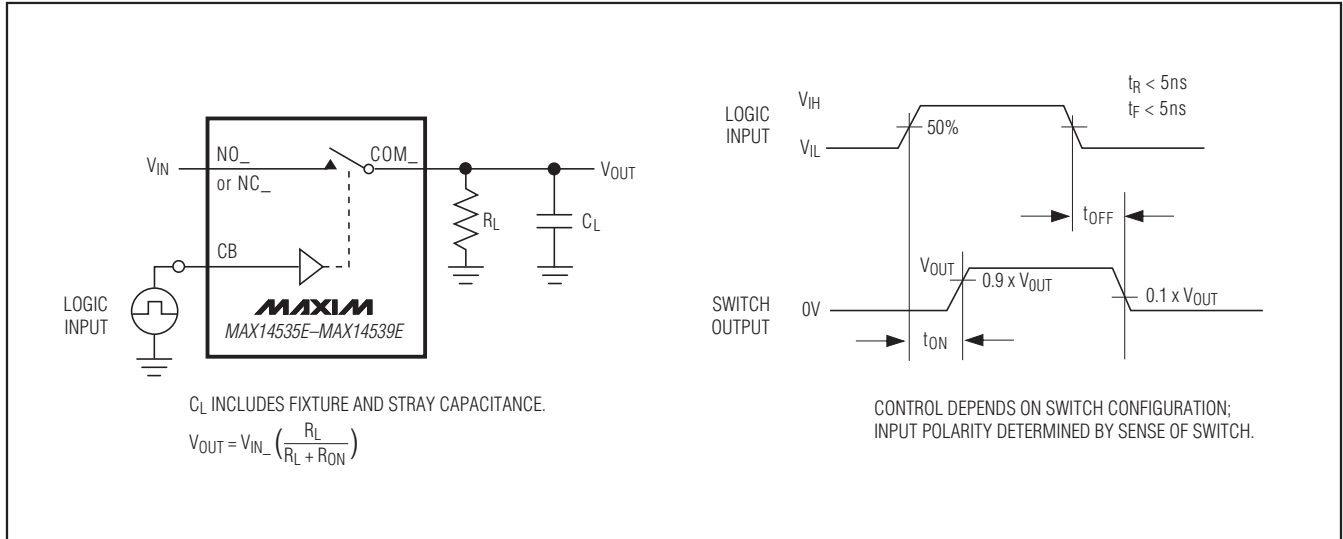

Figure 1. Switching Time

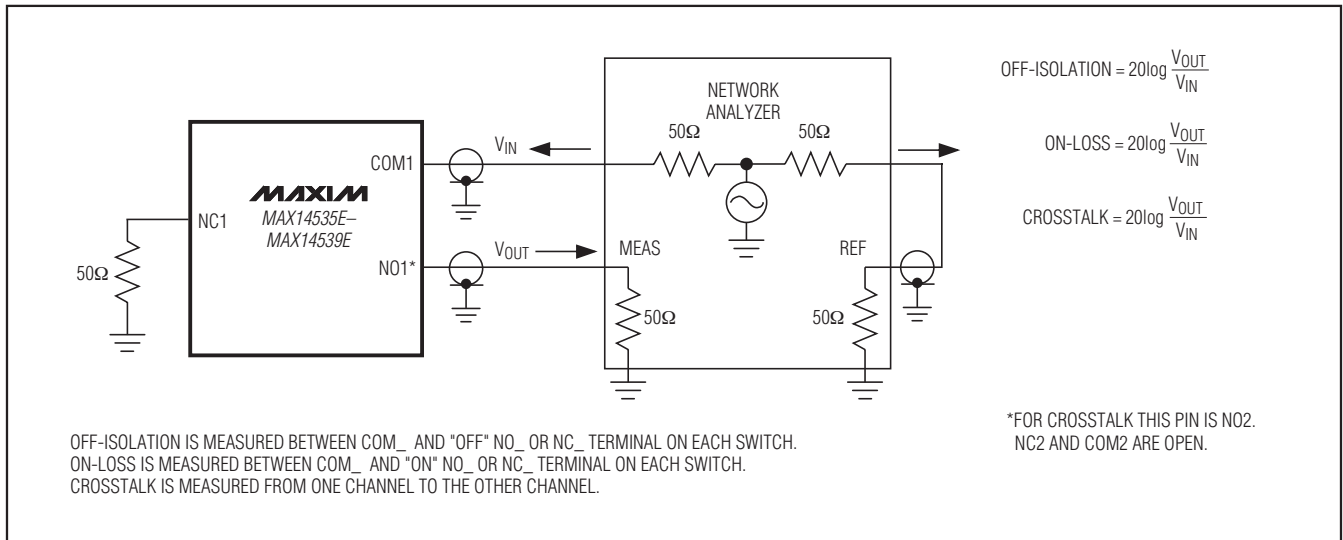

Figure 2. On-Loss, Off-Isolation, and Crosstalk

Low-Resistance DPDT Switches with Negative Rail

Typical Operating Characteristics

($T_A = +25^\circ\text{C}$, $V_{CC} = +3.0\text{V}$, unless otherwise noted.)

MAX14535E-MAX14539E

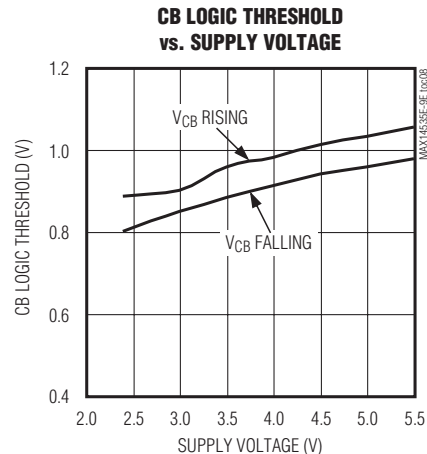
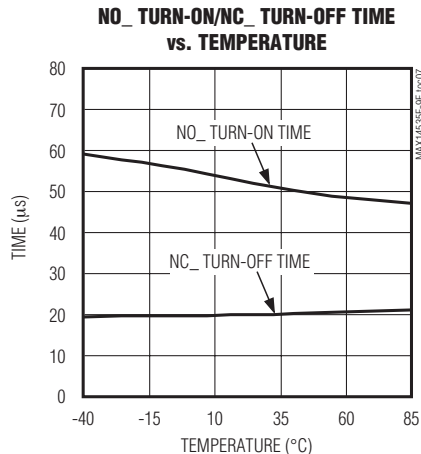
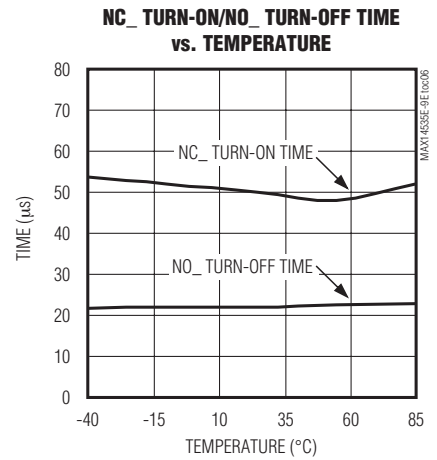
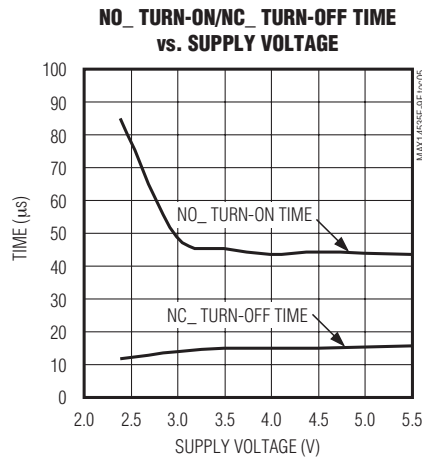
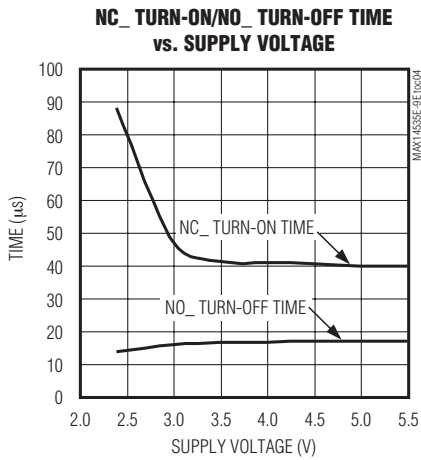
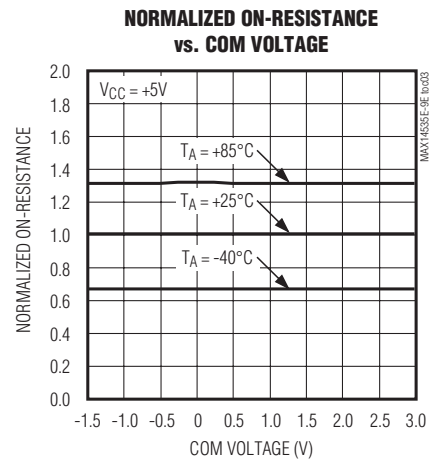
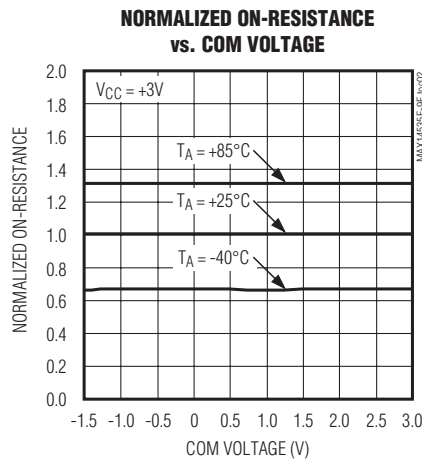
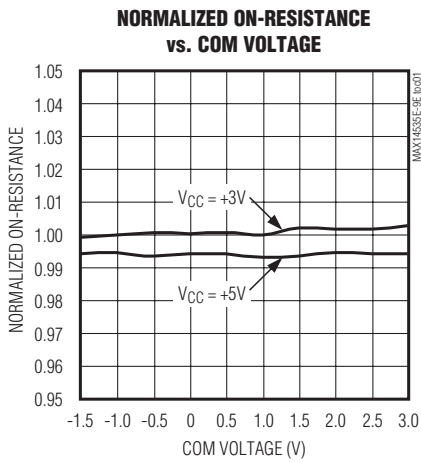

Low-Resistance DPDT Switches with Negative Rail

Typical Operating Characteristics (continued)

($T_A = +25^\circ\text{C}$, $V_{CC} = +3.0\text{V}$, unless otherwise noted.)

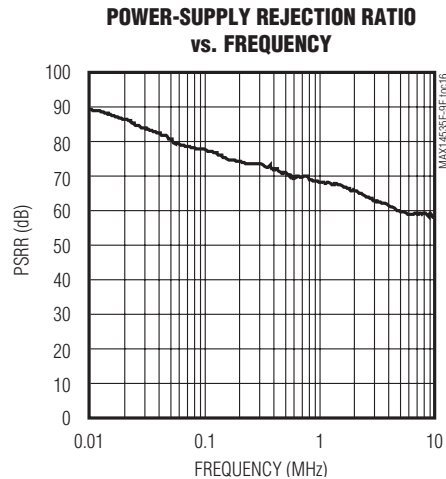
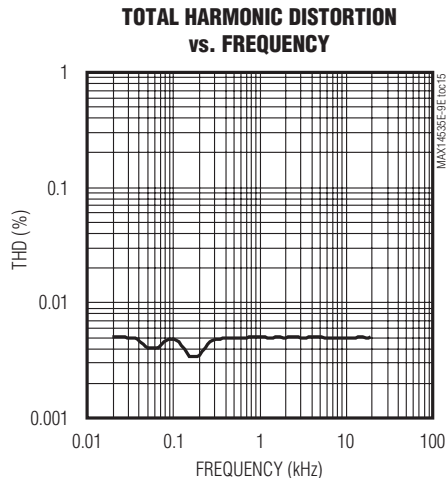
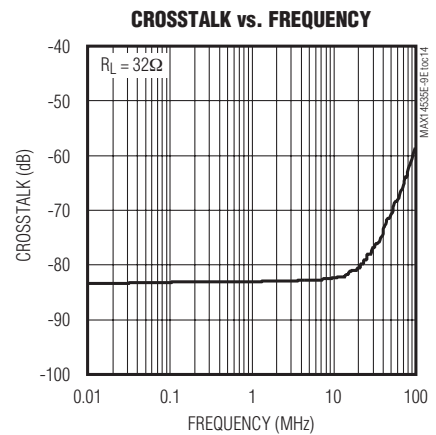
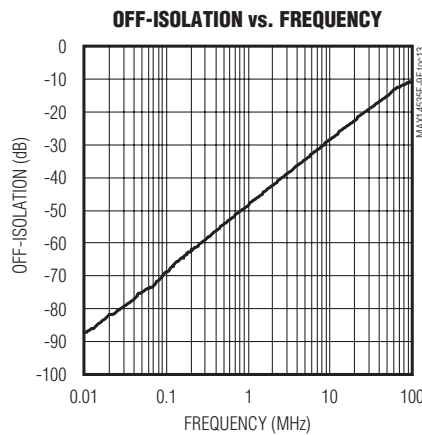
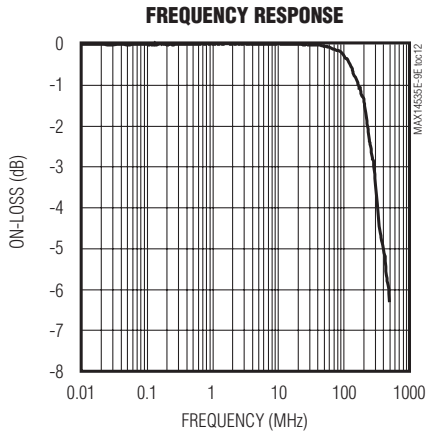
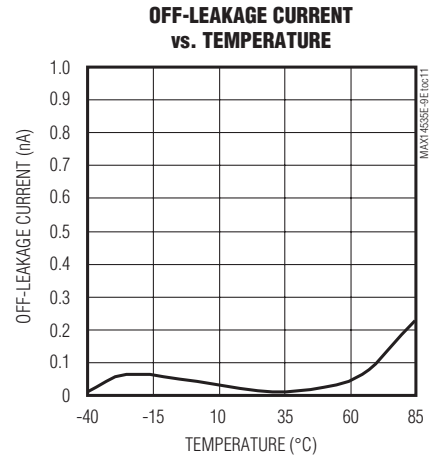
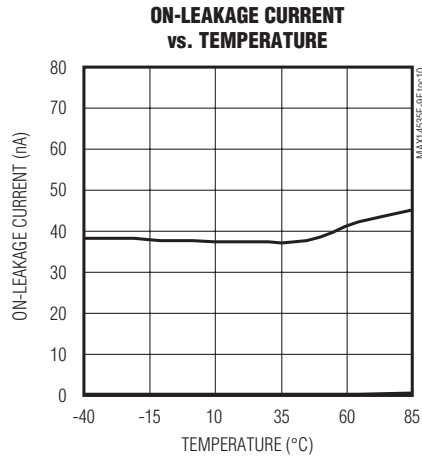
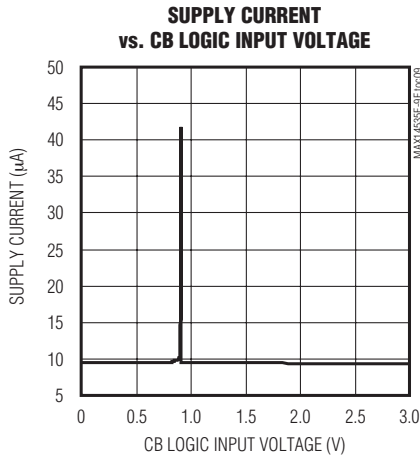

Low-Resistance DPDT Switches with Negative Rail

Pin Description

PIN	NAME	FUNCTION
1	CB	Digital Control Input. Drive CB low to connect COM_ to NC_. Drive CB high to connect COM_ to NO_.
2	EN	Active-High Enable Input. Drive EN high for normal operation. Drive EN low to put switches in high impedance. Do not apply negative signals to NO_ or NC_ when EN is low (MAX14537E/MAX14538E).
3	NO2	Normally Open Terminal for Switch 2
4	COM2	Common Terminal for Switch 2
5	NC2	Normally Close Terminal for Switch 2
6	GND	Ground
7	VCC	Positive Supply Voltage Input. Bypass VCC to GND with a 0.1μF capacitor as close as possible to the device.
8	NC1	Normally Close Terminal for Switch 1
9	COM1	Common Terminal for Switch 1
10	NO1	Normally Open Terminal for Switch 1

Detailed Description

The MAX14535E–MAX14539E are low on-resistance and high ESD-protected single DPDT switches that operate from a +2.4V to +5.5V supply and are designed to multiplex AC-coupled analog signals. These switches combine the low on-capacitance (C_{ON}) and low on-resistance (R_{ON}) necessary for high-performance switching applications. The negative signal capability of the analog channel allows signals below ground to pass through without distortion.

Analog Signal Levels

The MAX14535E–MAX14539E are bidirectional, allowing NO_, NC_, and COM_ to be configured as either inputs or outputs. Note that NC_ and NO_ are only protected against ESD up to $\pm 2\text{kV}$ (Human Body Model) and may require additional ESD protection if used as outputs. These devices feature a charge pump that generates a negative supply to allow analog signals as low as -1.5V to pass through NO_, NC_, or COM_. This allows AC-coupled signals that drop below ground to pass even when operating from a 3.0V to 5.5V supply. For the MAX14537E/MAX14538E, the negative charge pump is controlled by the enable input and is active when EN is high. When EN is driven low, the negative charge pump is disabled, which puts the devices in the lowest possible current consumption, and the signal range is 0 to VCC. The negative charge pump is always active for the MAX14535E/MAX14536E/MAX14539E, therefore, a negative signal (at most -1.5V) can be applied through NC_, NO_, or COM_, even when EN is driven low. A negative rail signal (signal voltage < 0) must not be applied to the switch unless the negative charge pump is active.

Digital Control Input

The MAX14535E–MAX14539E provide a single-bit control logic input, CB. CB controls the switch position as shown in the *Functional Diagrams*. Drive CB rail-to-rail to minimize power consumption.

Enable Input

The MAX14535E–MAX14539E feature a shutdown mode that reduces the supply current (less than 1μA for MAX14537E/MAX14538E) and places the switches in high impedance. Drive EN low to place the device in shutdown mode. Drive EN high for normal operation.

Shunt Resistors (MAX14535E/MAX14537E/MAX14539E)

When EN is high, the shunt resistors are controlled by CB. When CB is low, NC_ is connected to COM_ and NO_ is connected to shunt resistors. When CB is high, NO_ is connected to COM_ and NC_ is connected to shunt resistors (MAX14539E). When EN is low, all the switches are open and all the shunt resistors are active.

Click-and-Pop Suppression

The 500Ω shunt resistors on the MAX14535E/MAX14537E/MAX14539E automatically discharge any capacitance at the NO_ terminals (or NC_ terminals, MAX14539E) when they are unconnected from COM_. This reduces audio click-and-pop sounds that may occur when switching between capacitively coupled audio sources.

Low-Resistance DPDT Switches with Negative Rail

Applications Information

Extended ESD Protection

ESD protection structures are incorporated on all pins to protect against electrostatic discharges up to $\pm 2\text{kV}$ (HBM) encountered during handling and assembly. COM1 and COM2 are further protected against ESD up to $\pm 15\text{kV}$ (HBM) without damage. The ESD structures withstand high ESD both in normal operation and when the device is powered down. After an ESD event, the MAX14535E-MAX14539E continue to function without latchup.

ESD Test Conditions

ESD performance depends on a variety of conditions. Contact Maxim for a reliability report that documents test setup, test methodology, and test results.

Human Body Model

Figure 3a shows the Human Body Model. Figure 3b shows the current waveform it generates when discharged into a low impedance. This model consists of a 100pF capacitor charged to the ESD voltage of interest that is then discharged into the device through a $1.5\text{k}\Omega$ resistor.

IEC 61000-4-2

The main difference between tests done using the Human Body Model and IEC 61000-4-2 is higher peak current in the IEC 61000-4-2. Because series resistance is lower in the IEC 61000-4-2 ESD test model (Figure 3c) the ESD withstand voltage measured using the Human Body Model. Figure 3d shows the current waveform for the $\pm 8\text{kV}$ IEC 61000-4-2 Level 4 ESD Contact Discharge test.

The Air-Gap Discharge test involves approaching the device with a charged probe. The Contact Discharge method connects the probe to the device before the probe is energized.

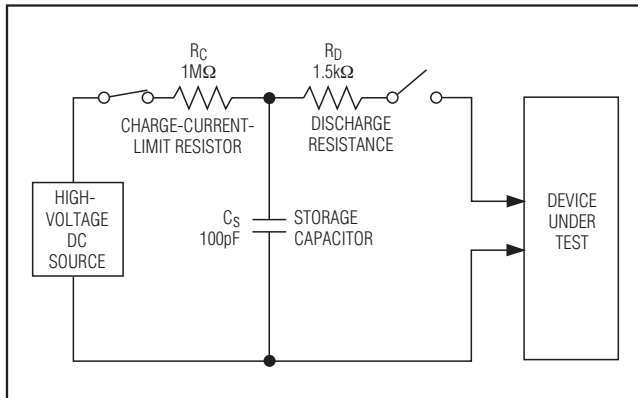

Figure 3a. Human Body ESD Test Model

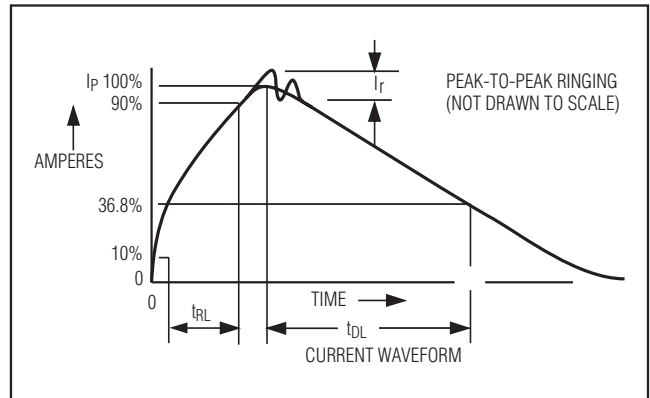

Figure 3b. Human Body Current Waveform

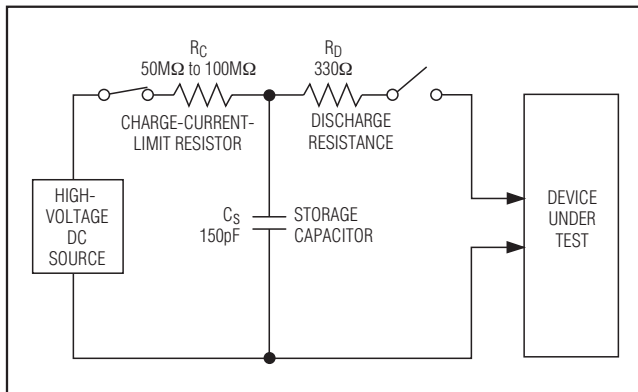

Figure 3c. IEC 61000-4-2 ESD Test Model

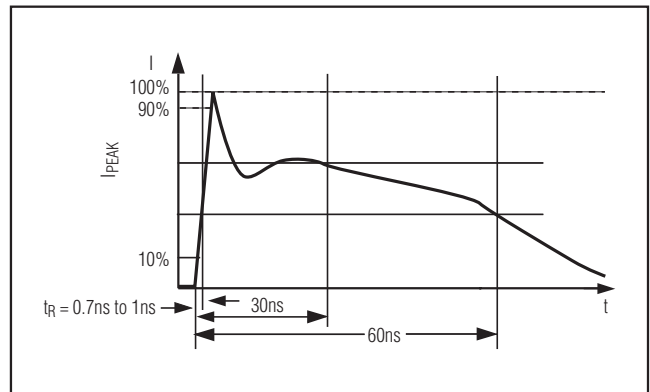

Figure 3d. IEC 61000-4-2 ESD Generator Current Waveform

Low-Resistance DPDT Switches with Negative Rail

Power-Supply Sequencing

Caution: Do not exceed the absolute maximum ratings because stresses beyond the listed ratings may cause permanent damage to the device.

Proper power-supply sequencing is recommended for all devices. Apply V_{CC} before applying analog signals, especially if the analog signal is not current limited.

Functional Diagrams

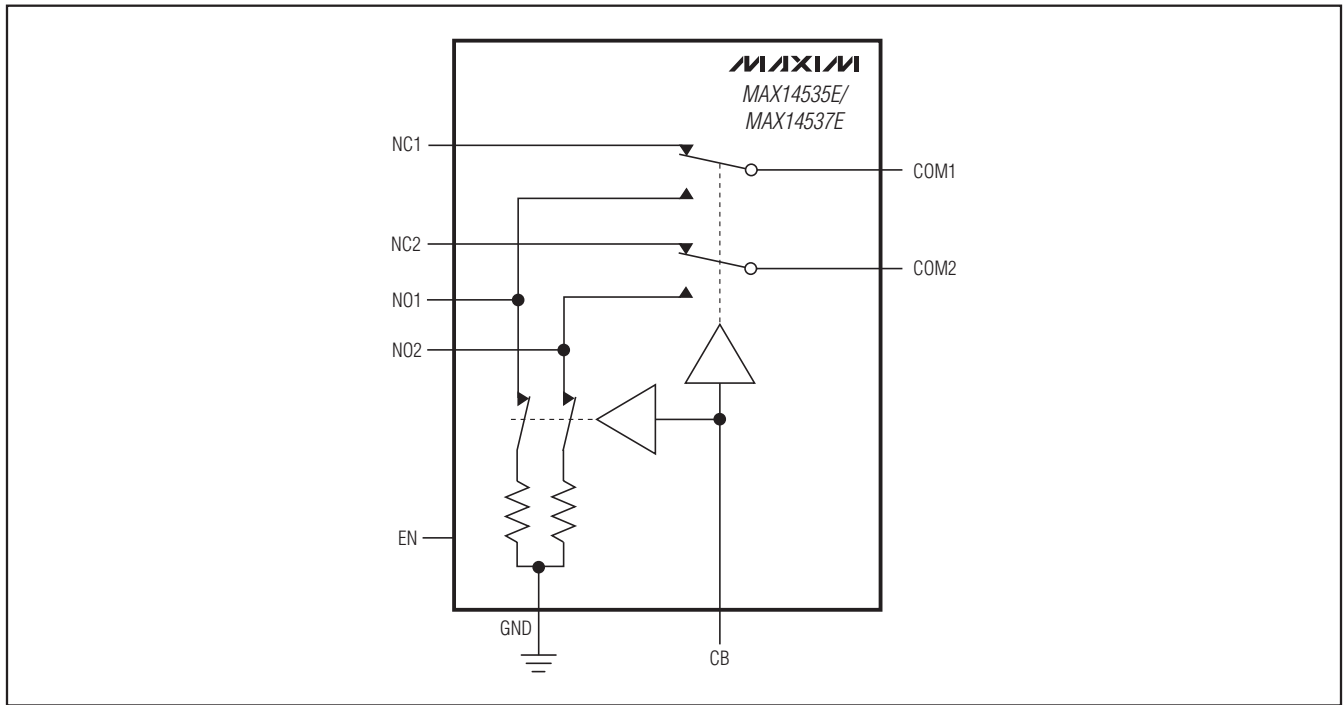

MAX14535E-MAX14539E

Low-Resistance DPDT Switches with Negative Rail

Functional Diagrams (continued)

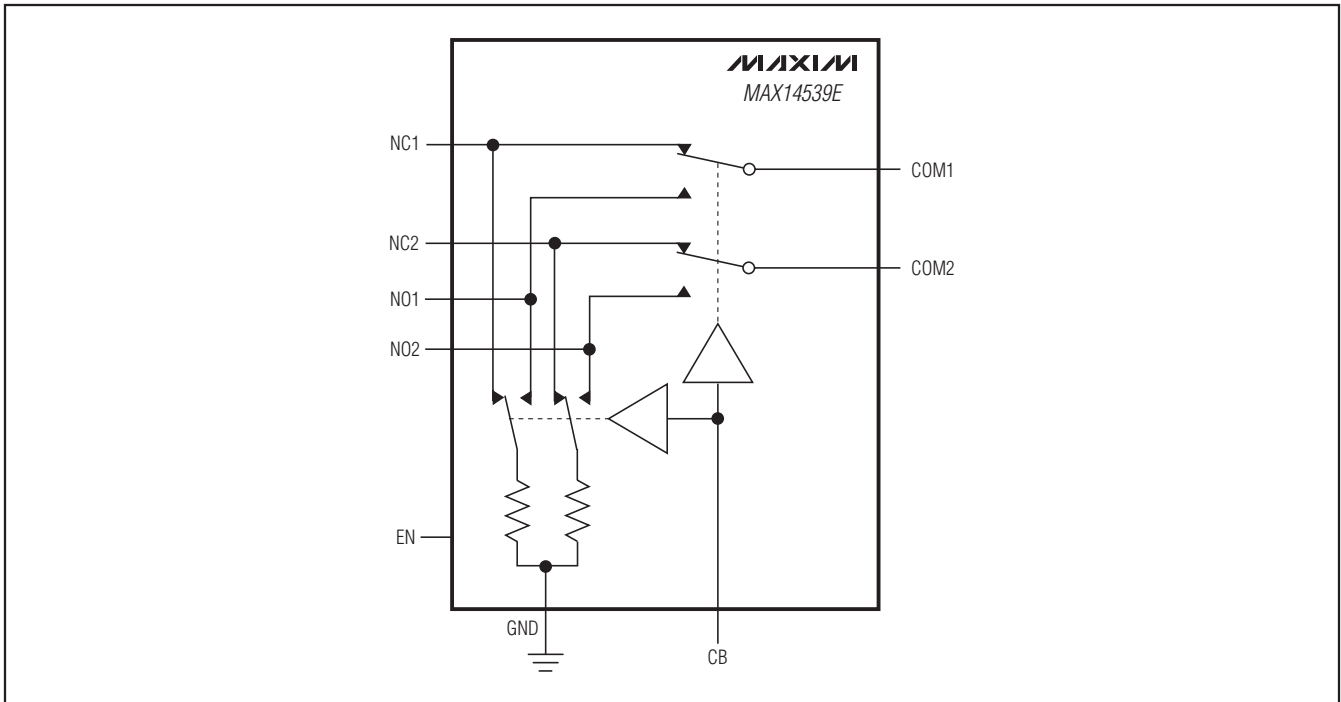
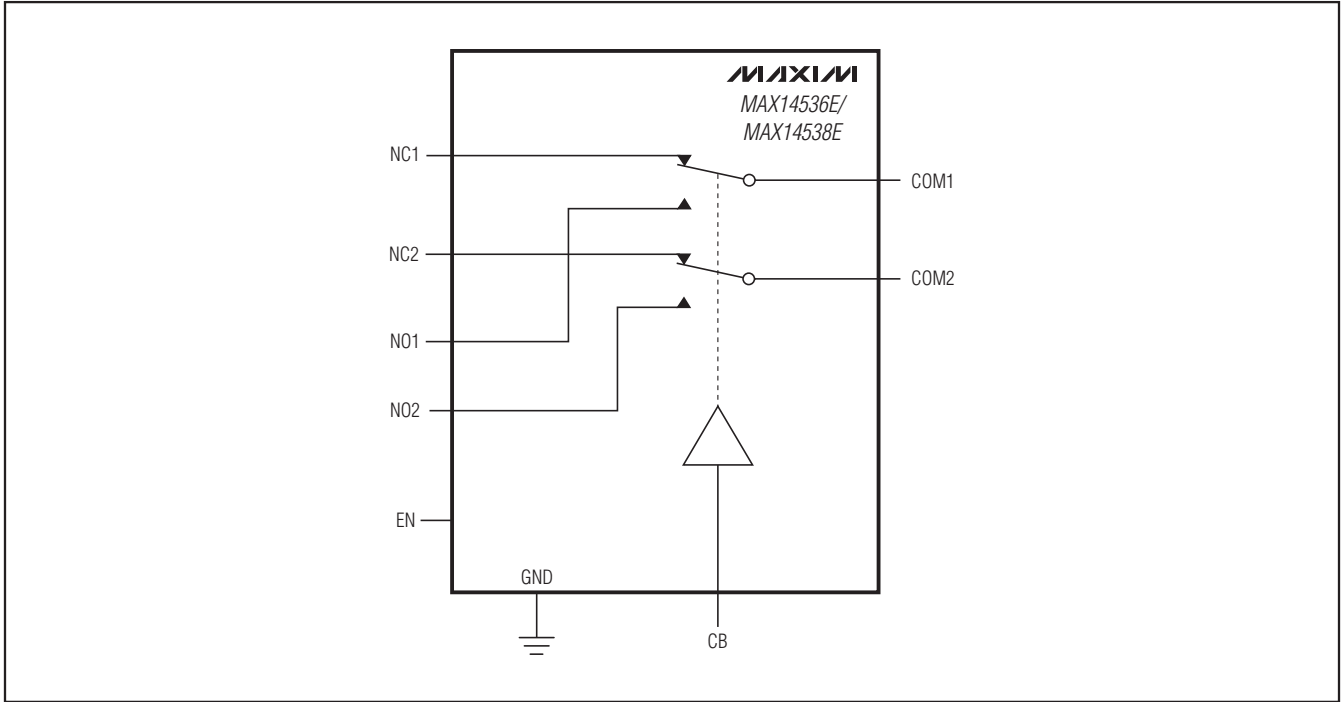

Low-Resistance DPDT Switches with Negative Rail

Typical Operating Circuits

MAX14535E-MAX14539E

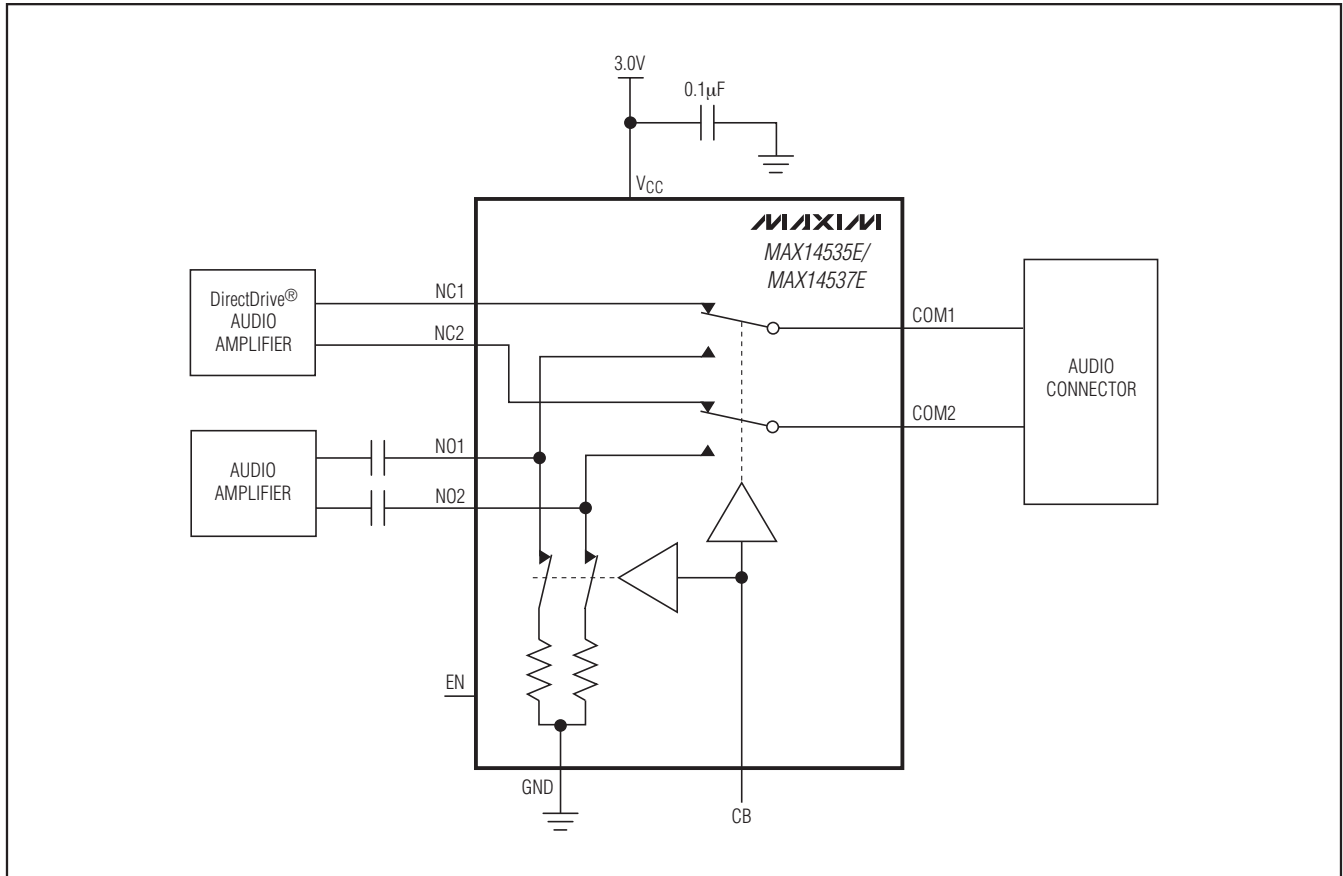

DirectDrive is a registered trademark of Maxim Integrated Products, Inc.

Low-Resistance DPDT Switches with Negative Rail

Typical Operating Circuits (continued)

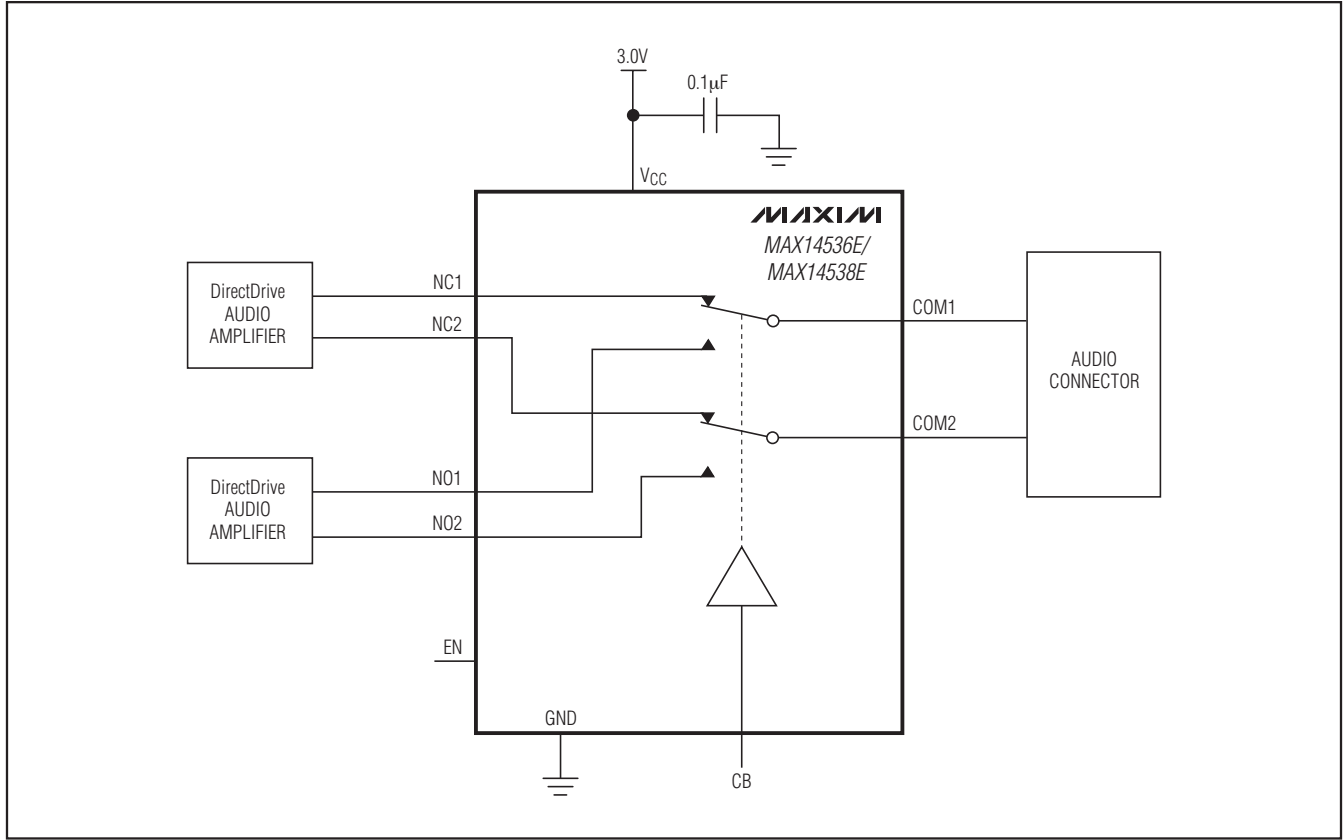

Chip Information

PROCESS: BICMOS

Package Information

For the latest package outline information and land patterns, go to www.maxim-ic.com/packages.

PACKAGE TYPE	PACKAGE CODE	DOCUMENT NO.
10 UTQFN	V101A1CN+1	21-0028

Low-Resistance DPDT Switches with Negative Rail

Revision History

REVISION NUMBER	REVISION DATE	DESCRIPTION	PAGES CHANGED
0	2/09	Initial release	—
1	4/09	Removed future product asterisk for MAX14536E and updated <i>Electrical Characteristics</i> table.	1

MAX14535E-MAX14539E

Maxim cannot assume responsibility for use of any circuitry other than circuitry entirely embodied in a Maxim product. No circuit patent licenses are implied. Maxim reserves the right to change the circuitry and specifications without notice at any time.

Maxim Integrated Products, 120 San Gabriel Drive, Sunnyvale, CA 94086 408-737-7600 _____ 13

Looking for pricing, stock, or lifecycle information?

Click below to explore more details on WIN SOURCE:

- ⊖ [View MAX14536EEVB+T on WIN SOURCE](#)
- ⊖ [Maxim Integrated Information](#)

Optimize Your Supply Chain with WIN SOURCE Solutions

- ✓ Global Sourcing Solution
- ✓ Obsolete Management
- ✓ Cost Control Management
- ✓ Shortage Management
- ✓ Alternative Solution
- ✓ Excess Inventory Management