



# THE DATASHEET OF FMB-24M





SPECIFICATIONS			
<u>DEVICE TYPE NAME</u> SANKEN SILICON SCHOTTKY BARRIER DIODE <b>FMB-24M</b>			
<p>1. Scope The present specifications shall apply to SanKen silicon diode, FMB-24M.</p> <p>2. General</p> <p>2.1 Type Silicon Schottky Barrier Diode</p> <p>2.2 Structure Resin Molded</p> <p>2.3 Application Pulse Rectification, etc</p> <p>3. Flammability UL94V-0 (Equivalent)</p> <p>4. Dimensions, Inner Structure and Marking</p> <p>4.1 Appearance The body shall be clean and shall not bear any stain, rust or flaw. The color of the case will be black.</p> <p>4.2 Dimensions Refer to 9.1</p> <p>4.3 Marking : Refer to 9.2</p> <p>4.4 Inner Structure : Refer to 9.3</p>			
DATE of PROCESSING	September/28/ 2013		
PREPAREE BY	M.TSURUOKA	/	/
CHECKED BY	H.UCHINO	/	/
APPROVED BY	Y.ARAI	/	/
		SPECIFICATION NUMBER	1/8
		<b>SSA-03414</b>	

## 5. Absolute Maximum Ratings

				FMB-24M	
No.	Item	Symbol	Unit	Rating	Conditions
1	Transient Peak Reverse Voltage	$V_{RSM}$	V	45	
2	Peak Reverse Voltage	$V_{RM}$	V	40	
3	Average Forward Current	$I_{F(AV)}$	A	6.0	$T_c \leq 123^\circ\text{C}$ , Sinewave
4	Peak Surge Forward Current	$I_{FSM}$	A	60	half sinewave, one shot
5	$I^2t$ Limiting Value	$I^2t$	$\text{A}^2\text{s}$	18	$1\text{msec} \leq t \leq 10\text{msec}$
6	Junction Temperature	$T_j$	$^\circ\text{C}$	-40~+150	
7	Storage Temperature	$T_{stg}$	$^\circ\text{C}$	-40~+150	
8	Dielectric Strength		kV	A.C. 1.0	Junction and case(1min.)

 6. Electrical Characteristics ( $T_a=25^\circ\text{C}$ , unless otherwise specified)

No.	Item	Symbol	Unit	Value	Conditions
1	Forward Voltage Drop	$V_F$	V	0.55 max.	$I_F=3.0\text{A}$
2	Reverse Leakage Current	$I_R$	mA	3.0 max.	$V_R=V_{RM}$
3	Reverse Leakage Current Under High Temperature	$H \cdot I_{R1}$	mA	30 max.	$V_R=V_{RM}$ , $T_j=125^\circ\text{C}$
		$H \cdot I_{R2}$	mA	100 max.	$V_R=V_{RM}$ , $T_j=150^\circ\text{C}$
4	Thermal Resistance	$R_{th(j-c)}$	$^\circ\text{C}/\text{W}$	4.0 Max.	Between Junction and case

\* No.1,2&3 show characteristics per one chip.

7. Reliability Test

7.1 Test Conditions

No.	Item	Rating	Conditions
1	Thermal Fatigue Test	5000 cycles	$\Delta T_j = 100^\circ\text{C}$
2	High Temperature Reverse Bias Test	1000 hours	$T_a = 80^\circ\text{C}$ , $V_R = V_{RM}(\text{D.C.})$ With Fin
3	Humidity Reverse Bias Test	500 hours	$T_a = 85^\circ\text{C}$ , R.H.=85%, $V_R = V_{RM} \times 0.8(\text{D.C.})$
4	High Temperature Storage Test	1000 hours	$T_a = 150^\circ\text{C}$
5	Moisture Resistance Test	1000 hours	$T_a = 85^\circ\text{C}$ , 85%R.H.
6	Thermal Shock Test	100 cycle	Ice-water(5min.) ~ R.T.(30sec.) ~ Boiling-water(5min.)
7	Temperature Cycle Test	100 cycle	$-40^\circ\text{C}(30\text{min.}) \sim +150^\circ\text{C}(30\text{min.})$
8	Pressure Cooker Test	96 hours	$2.03 \times 10^5 \text{Pa}$ , 100%R.H., Unsaturated equipment
9	Resistance to Soldering Heat Test	10 sec.	$260 \pm 5^\circ\text{C}$ , Dipping up to 1.5mm from case
		3 sec.	$350 \pm 5^\circ\text{C}$ , Dipping up to 1.5mm from case
10	Solderability Test	95%	$235 \pm 5^\circ\text{C}$ , 5sec., Using rosin flux
11	Lead Bend Test	2 times	Apply EIAJ ED-4701 A-111
12	Lead Pull Test	10 sec.	
13	Lead Twist Test	2 times	
14	Drop Test	10 times	Naturally drop from 1m height on maple plate

7.2 Acceptance Criteria

Base on the fulfillment of electrical characteristics of 6. Lead shall be not cut of No.11, 12 and 13.

8. Standard Test Condition

Standard test conditions are at  $T_a = 25^\circ\text{C}$  and R.H.=60%.

But it is also acceptable to do test under ordinary temperature and ordinary R.H. ( $T_a = 5 \sim 35^\circ\text{C}$ , R.H.=45~85%)

9. Dimensions, Inner Structure and Marking  
 9.1 Dimensions Refer

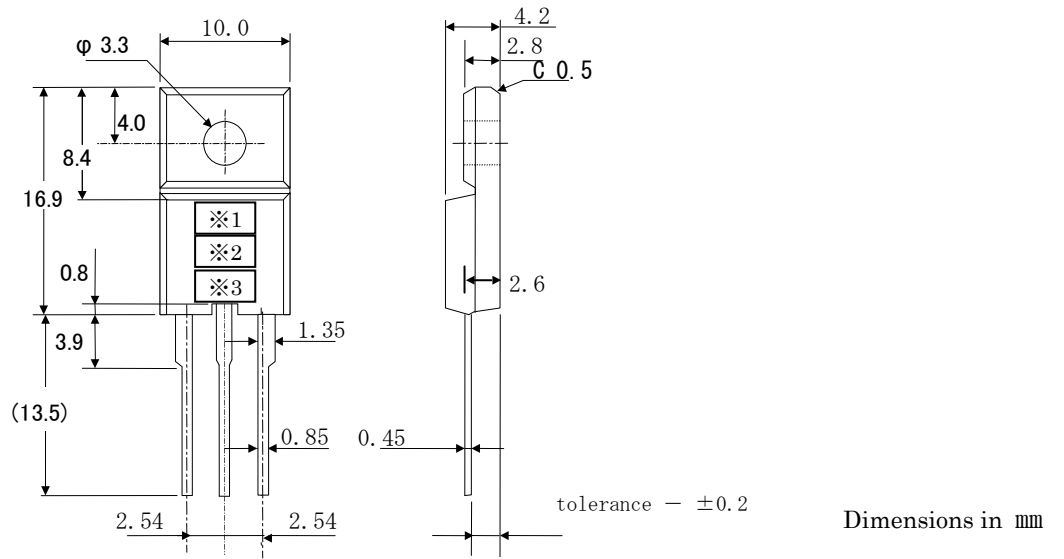

9.2 Marking

Type Name	Marking		
	* 1 Type Name	* 2 Polarity	* 3 Lot number
FMB-24M	FMB24M		1st letter: Last digit of year 2nd letter: Month From 1 to 9 for Jan. to Sep., O for Oct., N for Nov., D for Dec. 3rd & 4th letter: Day ex. 0125 (Jan.25, 2000)

9.3 Inner Structure and Material List

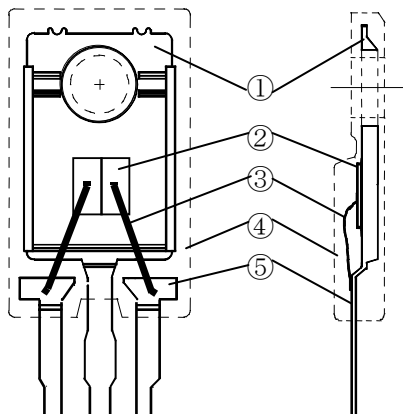

No.	Name of part	Materials
①	Frame: Heat Sink	Nickel Plated Copper
②	Chip	Silicon
③	Inner Leads	Aluminum Wire
④	Resin body	Epoxy Resin
⑤	Frame: Pin	Nickel Plated Copper + Solder Dipped

Weight of products: Approx. 2.1g

10. Characteristics

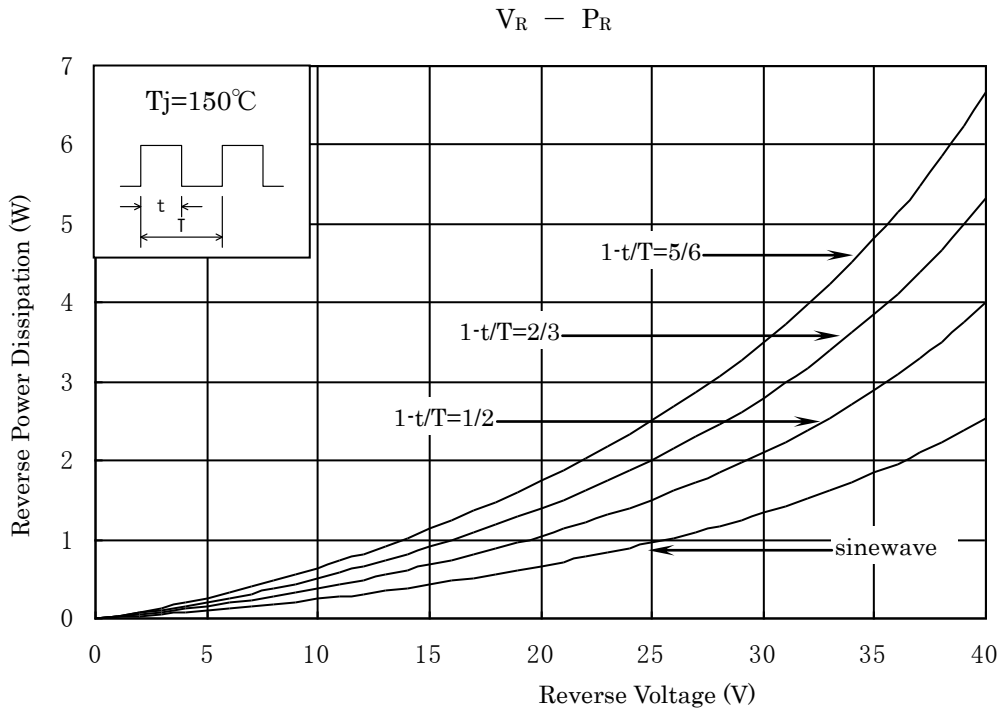
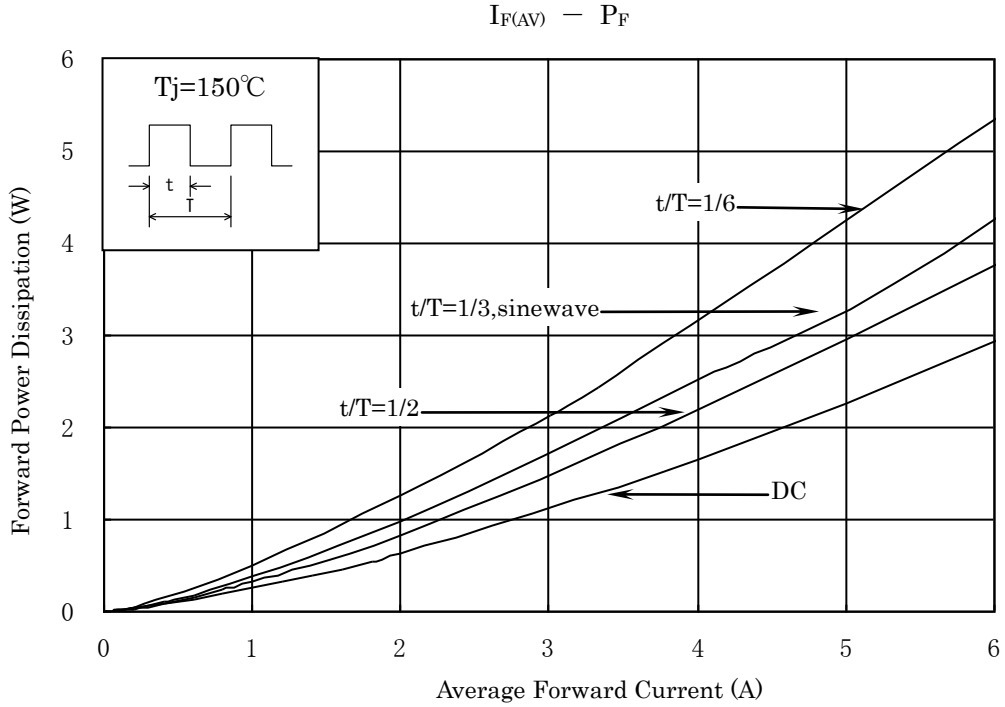

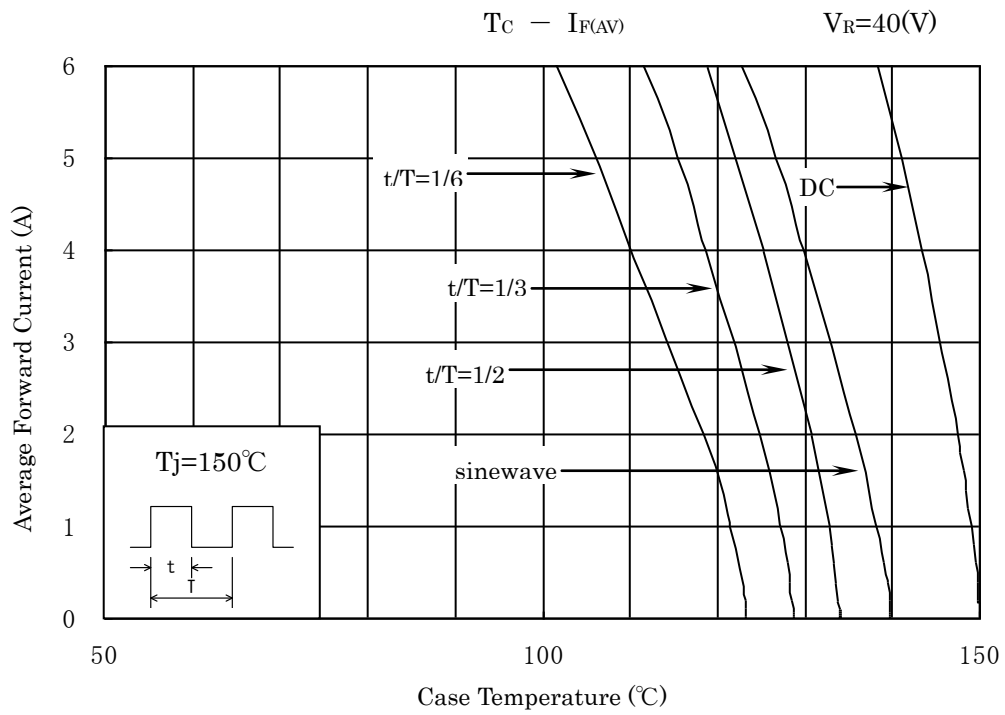

## † CAUTION/ WARNING

### Remarks in using silicone grease for a heat-sink

When silicone grease is used in mounting this product on a heat-sink, it shall be applied evenly and thinly. If more silicone grease than required is applied, it may produce forced stress.

Volatile type silicone grease may produce cracks after elapse of long term, resulting in reducing heat radiation effect. Silicone grease with low consistency (hard grease) may cause cracks in the mold resin when screwing the product to a heat-sink.

Depending on silicone grease to be used base oil separated from the silicone grease may penetrate into the product through possible thinner gaps between the mold resin and the lead-frame to cause wire breakage or cracks in the mold resin by swelling the coating material inside the product, resulting in the shorter product life. Therefore, silicone grease which contains base oil not causing swelling of coating materials must be selected.

Our recommended silicone grease for heat radiation purpose which will not cause any adverse effect on the product life is indicated below:

Type	Suppliers
<b>G746</b>	Shin-Etsu Chemical Co., Ltd.
<b>YG6260</b>	Toshiba Silicone Co., Ltd.
<b>SC102</b>	Dow Corning Toray Silicone Co., Ltd.

### (2) Mounting Method of Heatsink

- Torque when Tightening Screws Mounting

Thermal resistance increases when tightening torque is small, and radiation effects are decreased. When the torque is too high, the screw can cut, the heatsink can be deformed, and/or distortion can be arise in the product's frame. To avoid these problems, Table1. show the recommended tightening torque for each product type.

Table1. Screw Tightening Torque

Package			Screw Tightening Torque
MT25	FM20	(TO-220 & Full Mold)	0.490 to 0.686 N · m (5 to 7 kgf · cm)
MT100	FM100	(TO-3P & Full Mold)	0.686 to 0.882 N · m (7 to 9 kgf · cm)

- Diameter of hole of heatsink: Less than 4mm φ



As the slack of press mold for making the hole will be the cause of resin crack at the mounting, please pay special attention for that.

(3) Others

- Application and operation examples described in this document are quoted for the sole purpose of reference for the use of the products herein and SanKen can assume no responsibility for any infringement of industrial property rights, intellectual property rights or any other rights of SanKen or any third party which may result from its use.
- When using the products herein, the applicability and suitability of such products for the intended purpose object shall be reviewed at the users responsibility.
- Although SanKen undertakes to enhance the quality and reliability of its products, the occurrence of failure and defect of semiconductor products at a certain rate is inevitable. Users of SanKen products are requested to take, at their own risk, preventative measures including safety design of the equipment or systems against any possible injury, death, fires or damages to the society due to device failure or malfunction.
- SanKen products listed in this document are designed and intended for the use as components in general purpose electronic equipment or apparatus (home appliances, office equipment, telecommunication equipment, measuring equipment, etc.). Please return to us this document with your signature(s) or seal(s) prior to the use of the products herein.  
When considering the use of SanKen products in the applications where higher reliability is required (traffic signal control systems o equipment, fire/crime alarm systems, various safety devices, etc.), please contact your nearest SanKen sales representative to discuss, and then return to us this document with your signature(s) or seal(s) prior to the use of the products herein.  
The use of SanKen products without the written consent of SanKen in the applications where extremely high reliability is required (aerospace equipment, nuclear power control systems, life support systems, etc.) is strictly prohibited.
- Anti radioactive ray design is not considered for the products listed herein.

## Looking for pricing, stock, or lifecycle information?

Click below to explore more details on WIN SOURCE:

-  [View FMB-24M on WIN SOURCE](#)
-  [Sanken Information](#)

## Optimize Your Supply Chain with WIN SOURCE Solutions

-  Global Sourcing Solution
-  Obsolete Management
-  Cost Control Management
-  Shortage Management
-  Alternative Solution
-  Excess Inventory Management