



**THE DATASHEET OF  
MC10H330FN**



# MC10H330

## Quad Bus Driver/Receiver with 2-to-1 Output Multiplexers

### Description

The MC10H330 is a Quad Bus Driver/Receiver with two-to-one output multiplexers. These multiplexers have a common select and output enable. When disabled, ( $\overline{OE} = \text{high}$ ) the bus outputs go to  $-2.0\text{ V}$ . Their output can be brought to a low state ( $V_{OL}$ ) by applying a high level to the receiver enable ( $\overline{RE} = \text{High}$ ). The parameters specified are with  $25\ \Omega$  loading on the bus drivers and  $50\ \Omega$  loads on the receivers.

### Features

- Propagation Delay, 1.5 ns Typical Data-to-Output
- Improved Noise Margin 150 mV (Over Operating Voltage and Temperature Range)
- Voltage Compensated
- MECL 10K™ Compatible
- Pb-Free Packages are Available\*

### DIP PIN ASSIGNMENT

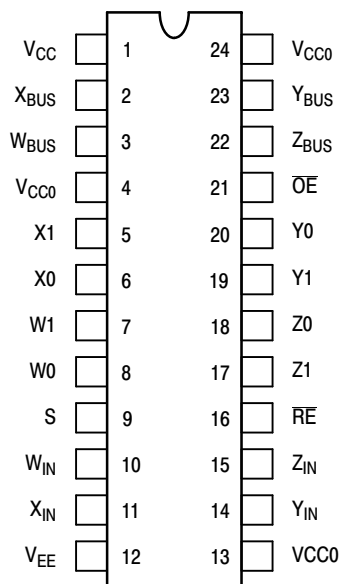

Pin assignment is for Dual-in-Line Package.  
For PLCC pin assignment, see the Pin Conversion Tables on page 18 of the ON Semiconductor MECL Data Book (DL122/D).



ON Semiconductor®

<http://onsemi.com>

### MARKING DIAGRAMS\*

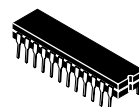

CDIP-24  
L SUFFIX  
CASE 758

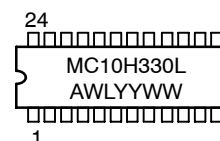

PDIP-24  
P SUFFIX  
CASE 724

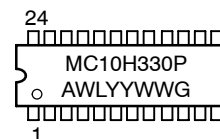

PLCC-28  
P SUFFIX  
CASE 776

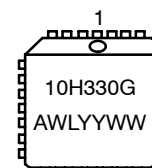

- A = Assembly Location
- WL = Wafer Lot
- YY = Year
- WW = Work Week
- G = Pb-Free Package

### ORDERING INFORMATION

See detailed ordering and shipping information in the package dimensions section on page 3 of this data sheet.

\*For additional information on our Pb-Free strategy and soldering details, please download the ON Semiconductor Soldering and Mounting Techniques Reference Manual, SOLDERRM/D.

# MC10H330

**Table 1. MAXIMUM RATINGS**

Symbol	Characteristic	Rating	Unit
V <sub>EE</sub>	Power Supply (V <sub>CC</sub> = 0)	-8.0 to 0	Vdc
V <sub>I</sub>	Input Voltage (V <sub>CC</sub> = 0)	0 to V <sub>EE</sub>	Vdc
I <sub>out</sub>	Output Current – Continuous – Surge	50 100	mA
T <sub>A</sub>	Operating Temperature Range	0 to +75	°C
T <sub>stg</sub>	Storage Temperature Range – Plastic – Ceramic	-55 to +150 -55 to +165	°C °C

Maximum ratings are those values beyond which device damage can occur. Maximum ratings applied to the device are individual stress limit values (not normal operating conditions) and are not valid simultaneously. If these limits are exceeded, device functional operation is not implied, damage may occur and reliability may be affected.

**Table 2. ELECTRICAL CHARACTERISTICS** (V<sub>EE</sub> = -5.2 V ±5%) (Note 1)

Symbol	Characteristic	0°		25°		75°		Unit
		Min	Max	Min	Max	Min	Max	
I <sub>E</sub>	Power Supply Current	-	157	-	143	-	157	mA
I <sub>inH</sub>	Input Current High							μA
	Pins 5-8, 17-20	-	667	-	417	-	417	
	Pins 16, 21	-	514	-	321	-	321	
	Pin 9	-	475	-	297	-	297	
I <sub>inL</sub>	Input Current Low	0.5	-	0.5	-	0.3	-	μA
V <sub>OH</sub>	High Output Voltage	-1.02	-0.84	-0.98	-0.81	-0.92	-0.735	Vdc
V <sub>OL</sub>	Low Output Voltage	-1.95	-1.63	-1.95	-1.63	-1.95	-1.60	Vdc
V <sub>IH</sub>	High Input Voltage	-1.17	-0.84	-1.13	-0.81	-1.07	-0.735	Vdc
V <sub>IL</sub>	Low Input Voltage	-1.95	-1.48	-1.95	-1.48	-1.95	-1.45	Vdc

1. Each MECL 10H™ series circuit has been designed to meet the dc specifications shown in the test table, after thermal equilibrium has been established. The circuit is in a test socket or mounted on a printed circuit board and transverse air flow greater than 500 lfpm is maintained. Receiver outputs are terminated through a 50 Ω resistor to -2.0 Vdc. Bus outputs are terminated through a 25 Ω resistor to -2.0 Vdc.

**Table 3. AC PARAMETERS**

Symbol	Characteristic	0°		25°		75°		Unit
		Min	Max	Min	Max	Min	Max	
t <sub>pd</sub>	Propagation Delay							ns
	Select-to-Input	1.8	5.3	1.8	5.3	1.8	5.3	
	Data-to-Bus Output	0.5	2.0	0.5	2.0	0.5	2.0	
	Select-to-Bus							
	Output	1.0	3.2	1.0	3.2	1.0	3.2	
	OE-to-Bus Output	0.8	2.2	0.8	2.2	0.8	2.2	
	Bus-to-Input	0.8	2.1	0.8	2.1	0.8	2.4	
	RE-to-Input	0.5	2.2	0.5	2.2	0.5	2.2	
	Data-to-Receiver							
	Input	1.3	4.0	1.3	4.0	1.3	4.0	
t <sub>r</sub>	Rise Time	0.5	2.0	0.5	2.0	0.5	2.0	ns
t <sub>f</sub>	Fall Time	0.5	2.0	0.5	2.0	0.5	2.0	ns

NOTE: Device will meet the specifications after thermal equilibrium has been established when mounted in a test socket or printed circuit board with maintained transverse airflow greater than 500 lfpm. Electrical parameters are guaranteed only over the declared operating temperature range. Functional operation of the device exceeding these conditions is not implied. Device specification limit values are applied individually under normal operating conditions and not valid simultaneously.

# MC10H330

## LOGIC DIAGRAM

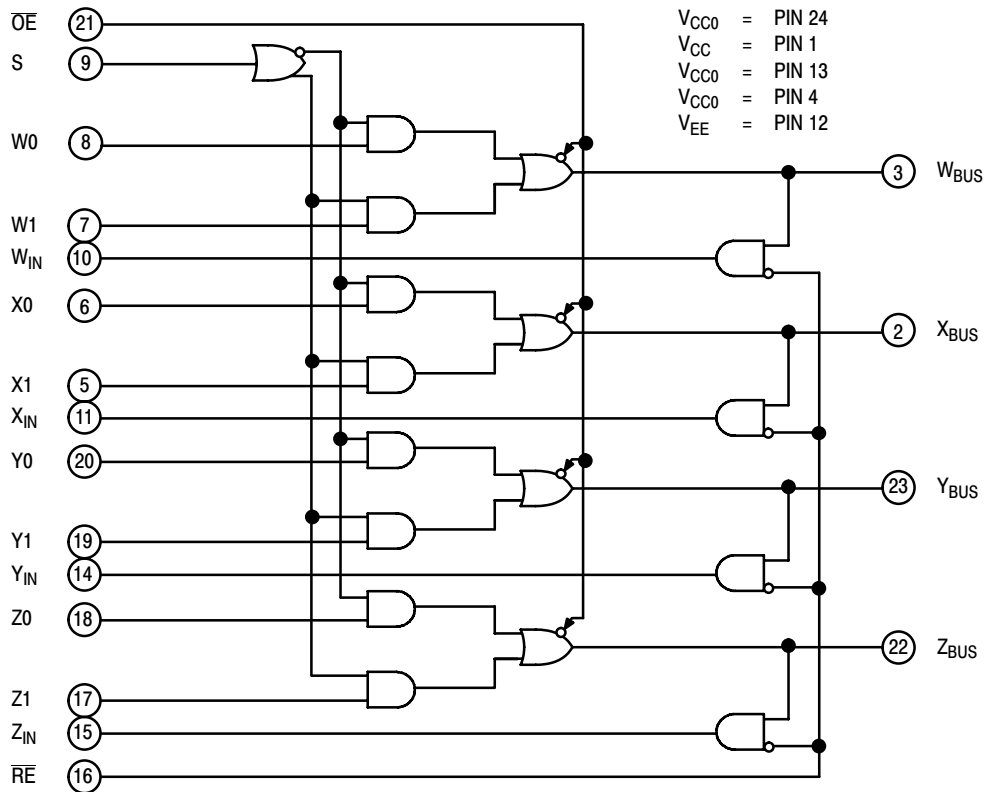

**MULTIPLEXER TRUTH TABLE**

$\overline{OE}$	S	W <sub>Bus</sub>	X <sub>Bus</sub>	Y <sub>Bus</sub>	Z <sub>Bus</sub>
H	X	-2.0 V	-2.0 V	-2.0 V	-2.0 V
L	L	W <sub>0</sub>	X <sub>0</sub>	Y <sub>0</sub>	Z <sub>0</sub>
L	H	W <sub>1</sub>	X <sub>1</sub>	Y <sub>1</sub>	Z <sub>1</sub>

**RECEIVER TRUTH TABLE**

RE	W <sub>in</sub>	X <sub>in</sub>	Y <sub>in</sub>	Z <sub>in</sub>
H	L	L	L	L
L	W <sub>Bus</sub>	X <sub>Bus</sub>	Y <sub>Bus</sub>	Z <sub>Bus</sub>

## ORDERING INFORMATION

Device	Package	Shipping <sup>†</sup>
MC10H330FN	PLCC-28	37 Units / Rail
MC10H330FNG	PLCC-28 (Pb-Free)	37 Units / Rail
MC10H330FNR2	PLCC-28	500 / Tape & Reel
MC10H330FNR2G	PLCC-28 (Pb-Free)	500 / Tape & Reel
MC10H330L	CDIP-24	15 Unit / Rail
MC10H330P	PDIP-24	15 Unit / Rail
MC10H330PG	PDIP-24 (Pb-Free)	15 Unit / Rail

# MC10H330

## PACKAGE DIMENSIONS

PLCC-28  
FN SUFFIX  
PLASTIC PLCC PACKAGE  
CASE 776-02  
ISSUE D

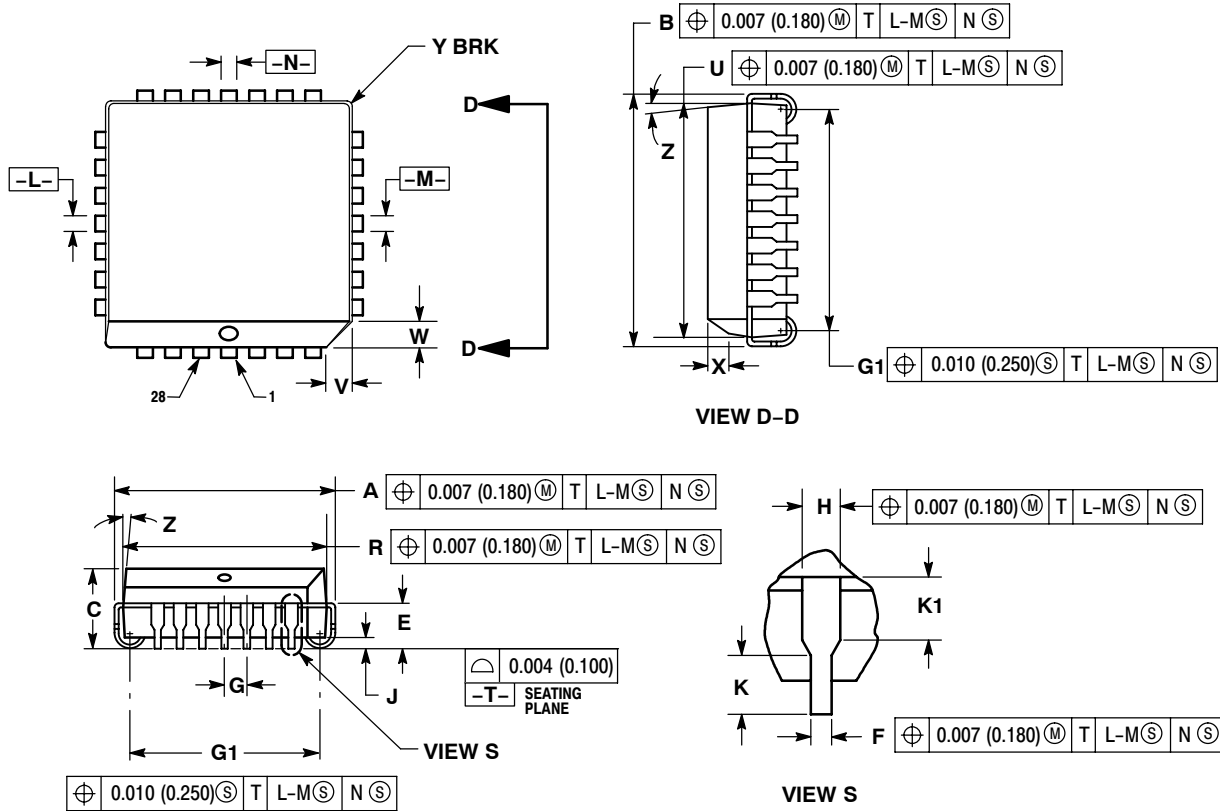

- NOTES:
- DATUMS -L-, -M-, AND -N- DETERMINED WHERE TOP OF LEAD SHOULDER EXITS PLASTIC BODY AT MOLD PARTING LINE.
  - DIMENSION G1, TRUE POSITION TO BE MEASURED AT DATUM -T-, SEATING PLANE.
  - DIMENSIONS R AND U DO NOT INCLUDE MOLD FLASH. ALLOWABLE MOLD FLASH IS 0.010 (0.250) PER SIDE.
  - DIMENSIONING AND TOLERANCING PER ANSI Y14.5M, 1982.
  - CONTROLLING DIMENSION: INCH.
  - THE PACKAGE TOP MAY BE SMALLER THAN THE PACKAGE BOTTOM BY UP TO 0.012 (0.300). DIMENSIONS R AND U ARE DETERMINED AT THE OUTERMOST EXTREMES OF THE PLASTIC BODY EXCLUSIVE OF MOLD FLASH, TIE BAR BURRS, GATE BURRS AND INTERLEAD FLASH, BUT INCLUDING ANY MISMATCH BETWEEN THE TOP AND BOTTOM OF THE PLASTIC BODY.
  - DIMENSION H DOES NOT INCLUDE DAMBAR PROTRUSION OR INTRUSION. THE DAMBAR PROTRUSION(S) SHALL NOT CAUSE THE H DIMENSION TO BE GREATER THAN 0.037 (0.940). THE DAMBAR INTRUSION(S) SHALL NOT CAUSE THE H DIMENSION TO BE SMALLER THAN 0.025 (0.635).

DIM	INCHES		MILLIMETERS	
	MIN	MAX	MIN	MAX
A	0.485	0.495	12.32	12.57
B	0.485	0.495	12.32	12.57
C	0.165	0.180	4.20	4.57
E	0.090	0.110	2.29	2.79
F	0.013	0.019	0.33	0.48
G	0.050 BSC		1.27 BSC	
H	0.026	0.032	0.66	0.81
J	0.020	---	0.51	---
K	0.025	---	0.64	---
R	0.450	0.456	11.43	11.58
U	0.450	0.456	11.43	11.58
V	0.042	0.048	1.07	1.21
W	0.042	0.048	1.07	1.21
X	0.042	0.056	1.07	1.42
Y	---	0.020	---	0.50
Z	2°	10°	2°	10°
G1	0.410	0.430	10.42	10.92
K1	0.040	---	1.02	---

# MC10H330

## PACKAGE DIMENSIONS

### CDIP-24 L SUFFIX CERAMIC DIP PACKAGE CASE 758-02 ISSUE A

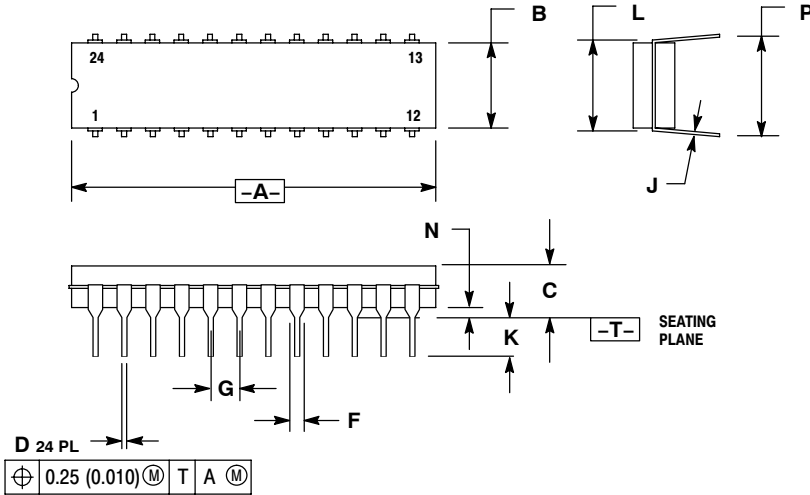

- NOTES:
- DIMENSIONING AND TOLERANCING PER ANSI Y14.5M, 1982.
  - CONTROLLING DIMENSION: INCH.
  - DIMENSION L TO CENTER OF LEADS WHEN FORMED PARALLEL.

DIM	INCHES		MILLIMETERS	
	MIN	MAX	MIN	MAX
A	1.240	1.285	31.50	32.64
B	0.285	0.305	7.24	7.75
C	0.160	0.200	4.07	5.08
D	0.015	0.021	0.38	0.53
F	0.045	0.062	1.14	1.57
G	0.100 BSC		2.54 BSC	
J	0.008	0.013	0.20	0.33
K	0.100	0.165	2.54	4.19
L	0.300	0.310	7.62	7.87
N	0.020	0.050	0.51	1.27
P	0.360	0.400	9.14	10.16

### PDIP-24 P SUFFIX PLASTIC DIP PACKAGE CASE 724-03 ISSUE D

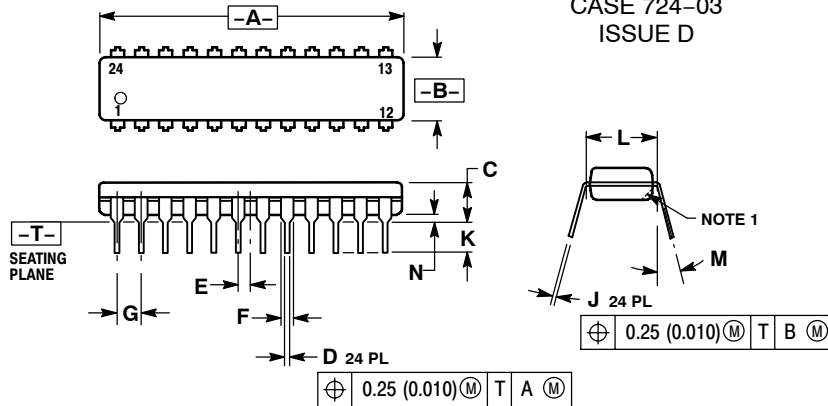

- NOTES:
- CHAMFERED CONTOUR OPTIONAL.
  - DIMENSION L TO CENTER OF LEADS WHEN FORMED PARALLEL.
  - DIMENSIONING AND TOLERANCING PER ANSI Y14.5M, 1982.
  - CONTROLLING DIMENSION: INCH.

DIM	INCHES		MILLIMETERS	
	MIN	MAX	MIN	MAX
A	1.230	1.265	31.25	32.13
B	0.250	0.270	6.35	6.85
C	0.145	0.175	3.69	4.44
D	0.015	0.020	0.38	0.51
E	0.050 BSC		1.27 BSC	
F	0.040	0.060	1.02	1.52
G	0.100 BSC		2.54 BSC	
J	0.007	0.012	0.18	0.30
K	0.110	0.140	2.80	3.55
L	0.300 BSC		7.62 BSC	
M	0°	15°	0°	15°
N	0.020	0.040	0.51	1.01

MECL 10H and MECL 10K are trademarks of Motorola, Inc.

**ON Semiconductor** and **UN** are registered trademarks of Semiconductor Components Industries, LLC (SCILLC). SCILLC reserves the right to make changes without further notice to any products herein. SCILLC makes no warranty, representation or guarantee regarding the suitability of its products for any particular purpose, nor does SCILLC assume any liability arising out of the application or use of any product or circuit, and specifically disclaims any and all liability, including without limitation special, consequential or incidental damages. "Typical" parameters which may be provided in SCILLC data sheets and/or specifications can and do vary in different applications and actual performance may vary over time. All operating parameters, including "Typicals" must be validated for each customer application by customer's technical experts. SCILLC does not convey any license under its patent rights nor the rights of others. SCILLC products are not designed, intended, or authorized for use as components in systems intended for surgical implant into the body, or other applications intended to support or sustain life, or for any other application in which the failure of the SCILLC product could create a situation where personal injury or death may occur. Should Buyer purchase or use SCILLC products for any such unintended or unauthorized application, Buyer shall indemnify and hold SCILLC and its officers, employees, subsidiaries, affiliates, and distributors harmless against all claims, costs, damages, and expenses, and reasonable attorney fees arising out of, directly or indirectly, any claim of personal injury or death associated with such unintended or unauthorized use, even if such claim alleges that SCILLC was negligent regarding the design or manufacture of the part. SCILLC is an Equal Opportunity/Affirmative Action Employer. This literature is subject to all applicable copyright laws and is not for resale in any manner.

## PUBLICATION ORDERING INFORMATION

**LITERATURE FULFILLMENT:**  
Literature Distribution Center for ON Semiconductor  
P.O. Box 61312, Phoenix, Arizona 85082-1312 USA  
**Phone:** 480-829-7710 or 800-344-3860 Toll Free USA/Canada  
**Fax:** 480-829-7709 or 800-344-3867 Toll Free USA/Canada  
**Email:** orderlit@onsemi.com

**N. American Technical Support:** 800-282-9855 Toll Free USA/Canada

**Japan:** ON Semiconductor, Japan Customer Focus Center  
2-9-1 Kamimeguro, Meguro-ku, Tokyo, Japan 153-0051  
**Phone:** 81-3-5773-3850

**ON Semiconductor Website:** <http://onsemi.com>

**Order Literature:** <http://www.onsemi.com/litorder>

For additional information, please contact your local Sales Representative.

## Looking for pricing, stock, or lifecycle information?

Click below to explore more details on WIN SOURCE:

 [View MC10H330FN](#) on WIN SOURCE

 [ON Semiconductor](#) Information

## Optimize Your Supply Chain with WIN SOURCE Solutions

-  Global Sourcing Solution
-  Obsolete Management
-  Cost Control Management
-  Shortage Management
-  Alternative Solution
-  Excess Inventory Management