



FC4B21300L1

Gate resistor installed Dual N-channel MOS FET

For lithium-ion secondary battery protection circuits

■ Features

- Source-source ON resistance: $R_{ss(on)}$ typ. = 80 m Ω (VGS = 3.8 V)
- CSP (Chip Size Package)
- RoHS compliant (EU RoHS / MSL: Level 1 compliant)

■ Marking Symbol: 29

■ Packaging

Embossed type (Thermo-compression sealing) : 1 000 pcs / reel (standard)

■ Absolute Maximum Ratings $T_a = 25\text{ }^\circ\text{C}$

Parameter	Symbol	Rating	Unit
Source-source Voltage	VSS	12	V
Gate-source Voltage	VGS	± 8	V
Source Current (DC)	I_S^{*1}	1.5	A
	I_S^{*2}	2	A
Source Current (Pulsed)	I_{Sp}^{*3}	15	A
Total Power Dissipation	PD^{*1}	0.32	W
	PD^{*2}	0.6	W
Channel Temperature	Tch	150	$^\circ\text{C}$
Storage Temperature Range	Tstg	-55 to +150	$^\circ\text{C}$
Thermal Resistance (ch-a)	R_{th}^{*1}	390	$^\circ\text{C/W}$
	R_{th}^{*2}	208	$^\circ\text{C/W}$

Note *1 Mounted on FR4 board (25.4 mm \times 25.4 mm \times t1.0 mm)

using the minimum recommended pad size (36 μm Copper).

*2 Mounted on Ceramic substrate (70 mm \times 70 mm \times t1.0 mm).

*3 $t = 10\ \mu\text{s}$, Duty Cycle $\leq 1\%$

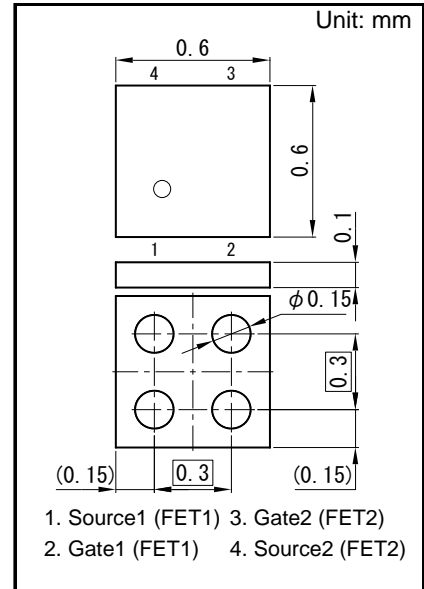

Panasonic	ALGA004-W-0606-RA
JEITA	—
Code	—

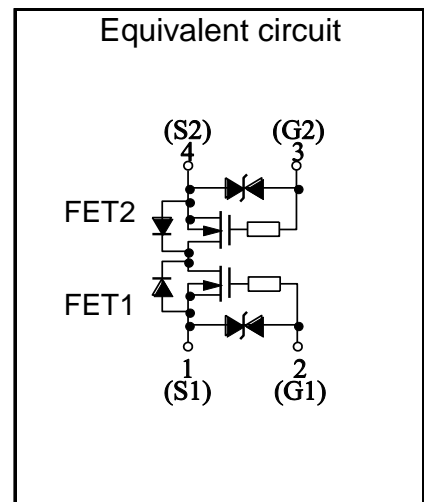

■ Electrical Characteristics Ta = 25 °C ± 3 °C

Parameter	Symbol	Conditions	Min	Typ	Max	Unit
Source-source Breakdown Voltage	VSSS	IS = 1 mA, VGS = 0 V	12			V
Zero Gate Voltage Source Current	ISSS	VSS = 12 V, VGS = 0 V			1.0	μA
Gate-source Leakage Current	IGSS	VGS = ±8 V, VSS = 0 V			±10	μA
		VGS = ±5 V, VSS = 0 V			±1.0	
Gate-source Threshold Voltage	Vth	IS = 0.03 mA, VSS = 10 V	0.35	0.90	1.4	V
Source-source On-state Resistance	RSS(on)1	IS = 0.75 A, VGS = 4.5 V	55	70	95	mΩ
	RSS(on)2	IS = 0.75 A, VGS = 3.8 V	60	80	110	
	RSS(on)3	IS = 0.75 A, VGS = 3.1 V	65	90	150	
	RSS(on)4	IS = 0.75 A, VGS = 2.5 V	70	115	225	
Body Diode Forward Voltage	VF(s-s)	IF = 0.75 A, VGS = 0 V		0.6	1.2	V
Input Capacitance ^{*1}	Ciss	VSS = 10 V, VGS = 0 V, f = 1 MHz		115		pF
Output Capacitance ^{*1}	Coss			25		
Reverse Transfer Capacitance ^{*1}	Crss			18		
Turn-on delay Time ^{*1,*2}	td(on)	VDD = 10 V, VGS = 0 to 4.0 V		0.10		μs
Rise Time ^{*1,*2}	tr	IS = 0.75 A		0.20		
Turn-off delay Time ^{*1,*2}	td(off)	VDD = 10 V, VGS = 4.0 to 0 V		0.27		μs
Fall Time ^{*1,*2}	tf	IS = 0.75 A		0.22		
Total Gate Charge ^{*1}	Qg	VDD = 10 V		1.7		nC
Gate-source Charge ^{*1}	Qgs	VGS = 0 to 4.0 V,		0.5		
Gate-drain Charge ^{*1}	Qgd	IS = 0.75 A		0.45		

Note Measuring methods are based on JAPANESE INDUSTRIAL STANDARD JIS C 7030 Measuring methods for transistors.

*1 Guaranteed by design, not subject to production testing

*2 Measurement circuit for Turn-on Delay Time / Rise Time / Turn-off Delay Time / Fall Time

Note2 : Measurement circuit

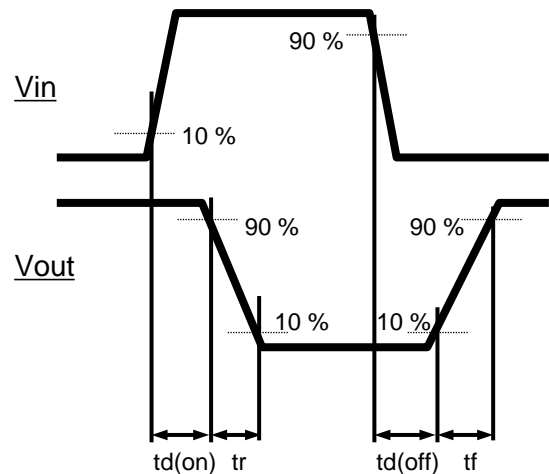
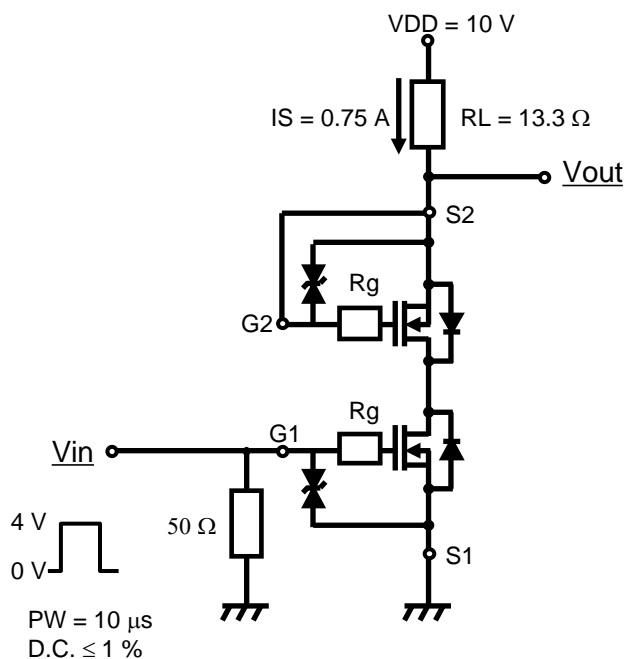

Technical Data (reference)

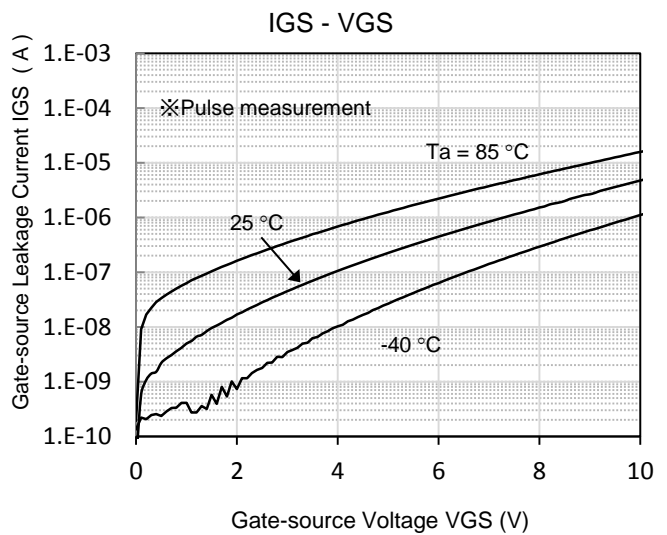
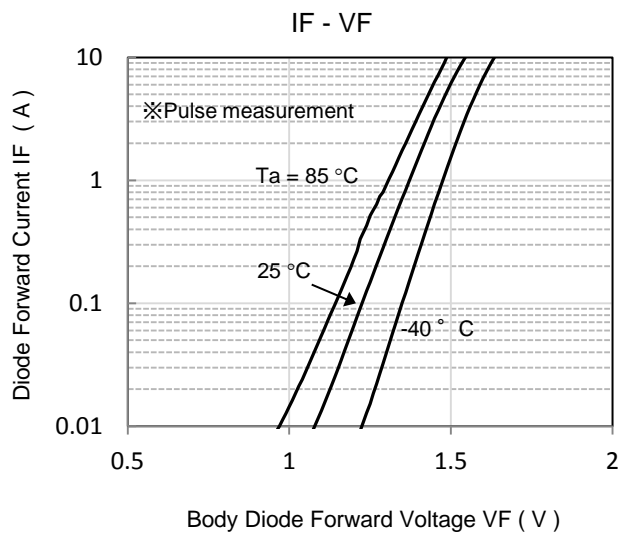
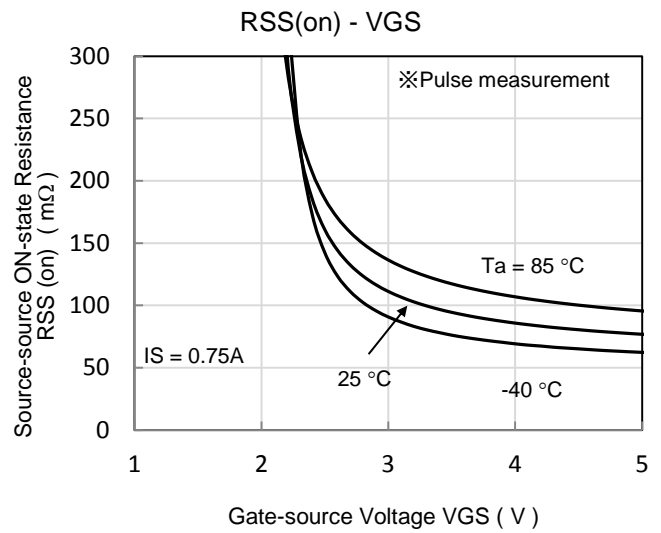
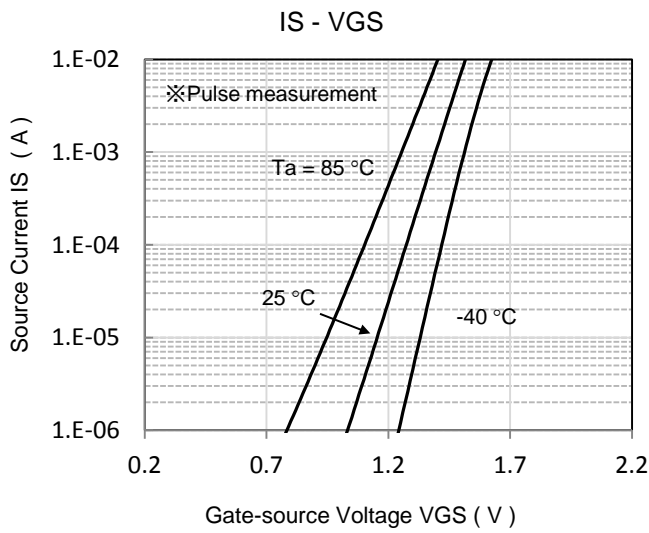
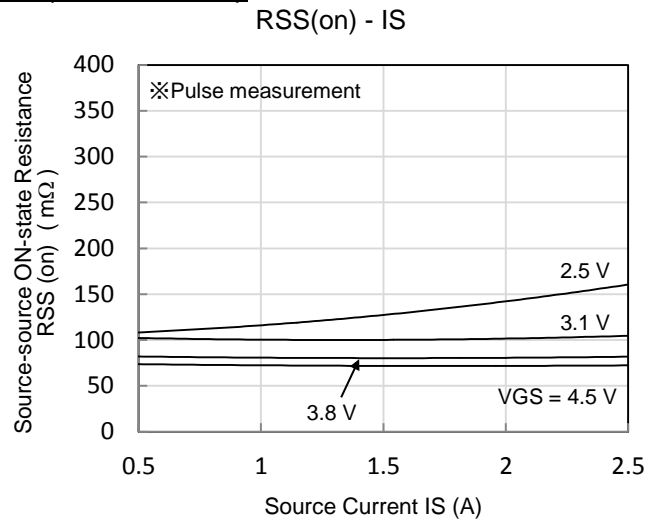
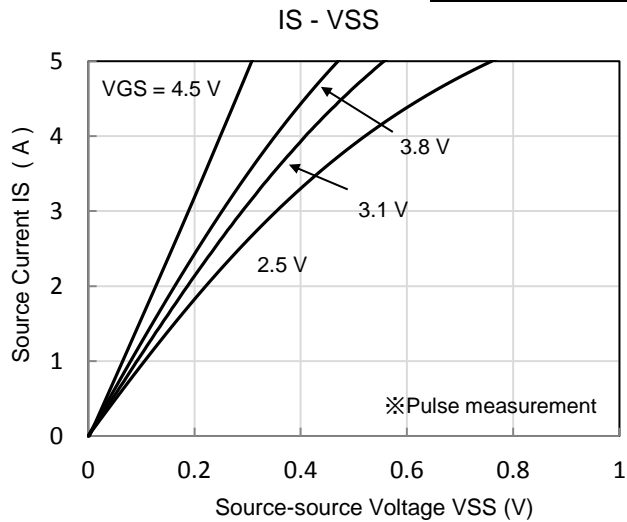



Technical Data (reference)

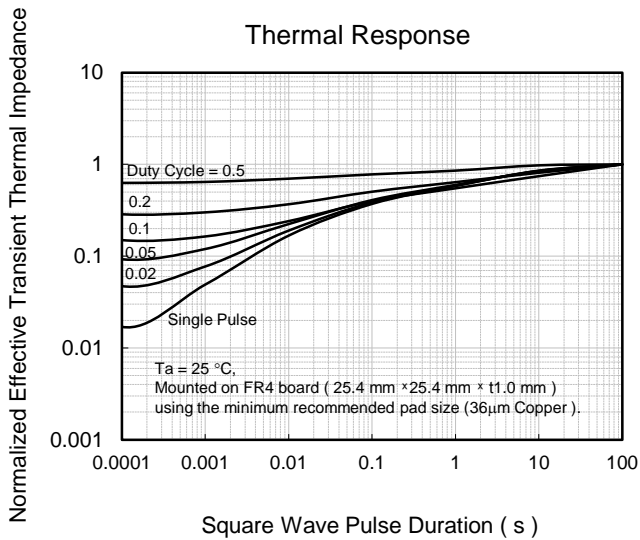
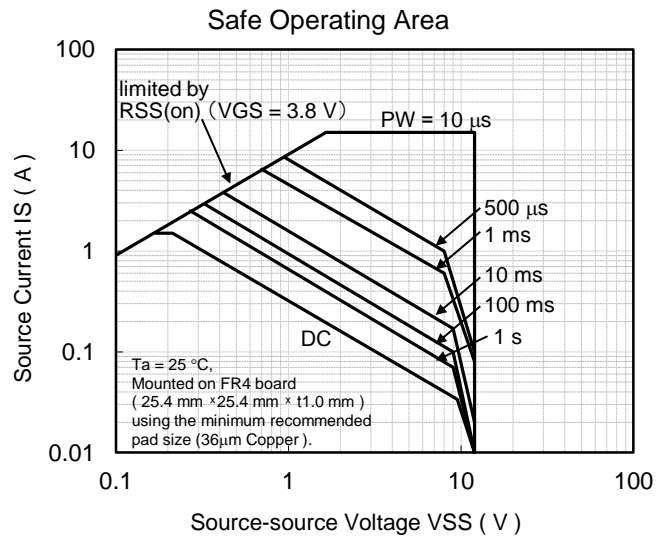
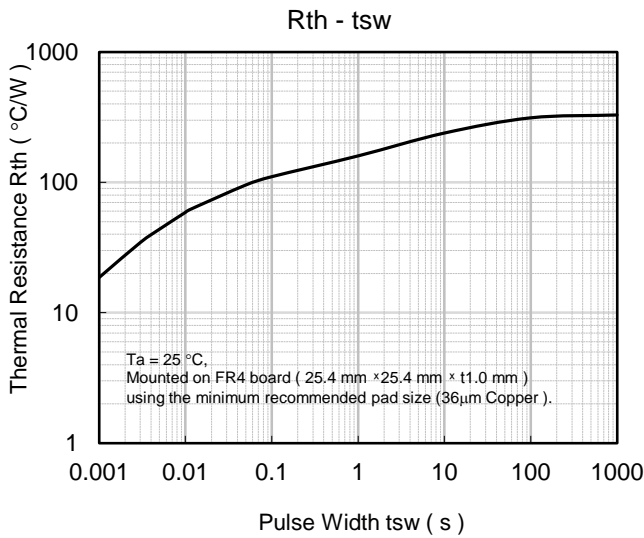
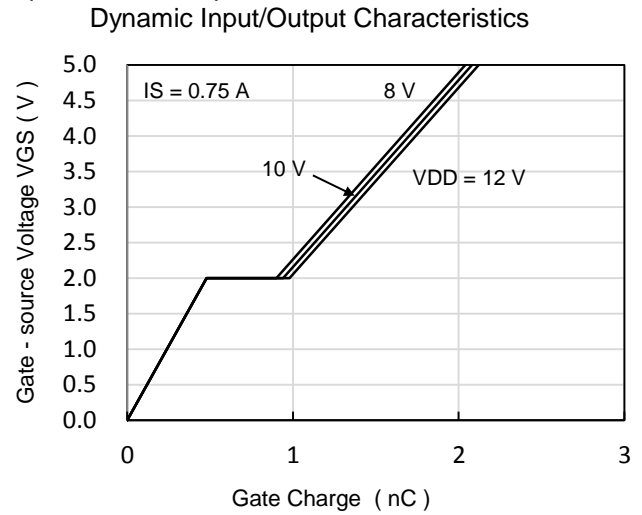
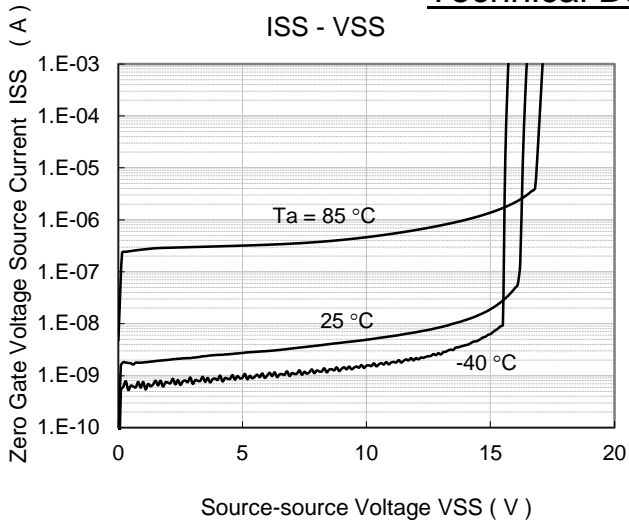

■ Outline (ALGA004-W-0606-RA)

Unit: mm

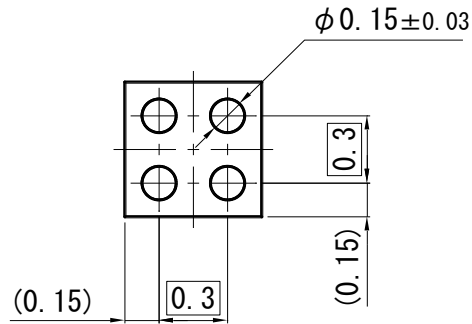
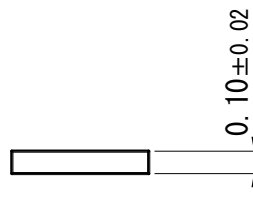
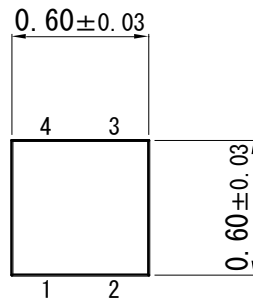

■ Land Pattern (Reference)

Unit: mm

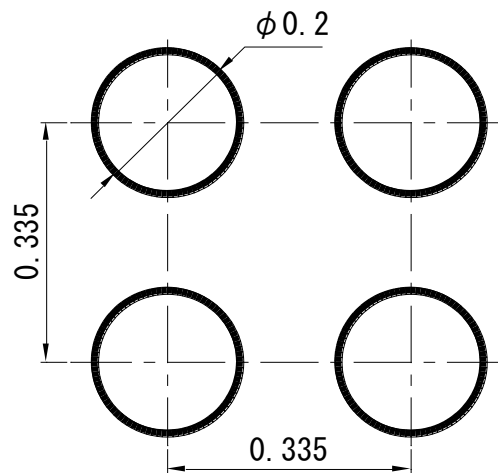

utions in using the technical information and scribed in this book

s book is to be exported or provided to non-residents, the laws and
rd to security export control, must be observed.

ly to show the main characteristics and application circuit examples
roperty right or other right owned by Panasonic Corporation or any
company as to the infringement upon any such right owned by any
l information described in this book.

or general applications (such as office equipment, communications
r for specific applications as expressly stated in this book.

ng applications:

ative equipment, traffic signaling equipment, combustion equipment,
quality and reliability are required, or if the failure or malfunction of
ody.

nsible for any damage incurred as a result of or in connection with
pplication, unless our company agrees to your using the products in

k are subject to change without notice for modification and/or im-
use of the products, therefore, ask for the most up-to-date Product
atisfy your requirements.

bsolute maximum rating and the guaranteed operating conditions
(.). Especially, please be careful not to exceed the range of absolute
er-off and mode-switching. Otherwise, we will not be liable for any



take into the consideration of incidence of break down and failure
n the systems such as redundant design, arresting the spread of fire
al injury, fire, social damages, for example, by using the products.

own and characteristics change due to external factors (ESD, EOS,
mounting or at customer's process. When using products for which
shelf life and the elapsed time since first opening the packages.







partially, without the prior written permission of our company.

Looking for pricing, stock, or lifecycle information?

Click below to explore more details on WIN SOURCE:

-  [View FC4B21300L1 on WIN SOURCE](#)
-  [Panasonic Information](#)

Optimize Your Supply Chain with WIN SOURCE Solutions

-  Global Sourcing Solution
-  Obsolete Management
-  Cost Control Management
-  Shortage Management
-  Alternative Solution
-  Excess Inventory Management