



SY89853U

Precision Low-Power Dual 2:1 LVPECL MUX with Internal Termination

General Description

The SY89853U features two, low jitter 2:1 differential multiplexers with 100K LVPECL (800mV) compatible outputs, capable of handling clocks up to 2.5GHz and data streams up to 2.5Gbps.

The SY89853U differential inputs include Micrel's unique, 3-input termination architecture that allows users to interface to any differential signal (AC- or DC-Coupled) as small as 100mV without any level shifting or termination resistors networks in the signal path. The result is a clean, stub-free, low jitter interface solution. The differential 800mV LVPECL outputs have fast rise/fall times guaranteed to be less than 180ps.

The SY89853U operates from a 2.5V $\pm 5\%$ or a 3.3V $\pm 10\%$ supply, and is guaranteed over the full industrial temperature range (-40°C to $+85^{\circ}\text{C}$). For applications that require higher performance, consider the SY58026U. The SY89853U is part of Micrel's Precision Edge[®] product family.

All support documentation can be found on Micrel's web site at www.micrel.com.



Precision Edge[®]

Features

- Dual 2:1 MUX, each channel selects from inputs
- Unique, patent-pending input isolation design minimizes crosstalk
- Low power 210mW ($V_{CC} = 2.5\text{V}$)
- Guaranteed AC performance over temperature and voltage:
 - DC-to->2.5Gbps data rate throughput
 - $<360\text{ps}$ IN-to-Q t_{pd}
 - $<180\text{ps}$ t_r/t_f times
- Ultra-low jitter design:
 - $<1\text{ps}_{RMS}$ random jitter
 - $<10\text{ps}_{PP}$ deterministic jitter
 - $<10\text{ps}_{PP}$ total jitter (clock)
 - $<0.7\text{ps}_{RMS}$ crosstalk-induced jitter
- Unique, patent-pending 50 Ω input termination and VT pin accepts DC- and AC-coupled inputs (CML, LVDS, PECL)
- 800mV LVPECL output swing
- Power supply 2.5V $\pm 5\%$ or 3.3V $\pm 10\%$
- -40°C to $+85^{\circ}\text{C}$ temperature range
- Available in 32-pin (5mm x 5mm) QFN package

Applications

- Data communication systems
- All SONET OC-3 to OC-48 applications
- All Fibre Channel applications
- All GigE applications

Markets

- LAN/WAN communication
- Enterprise servers
- ATE
- Test and measurement

United States Patent No. RE44,134

Precision Edge is a registered trademark of Micrel, Inc

Micrel Inc. • 2180 Fortune Drive • San Jose, CA 95131 • USA • tel +1 (408) 944-0800 • fax + 1 (408) 474-1000 • <http://www.micrel.com>

August 2007

M9999-082907-C
hbwhelp@micrel.com or (408) 955-1690

Functional Block Diagram

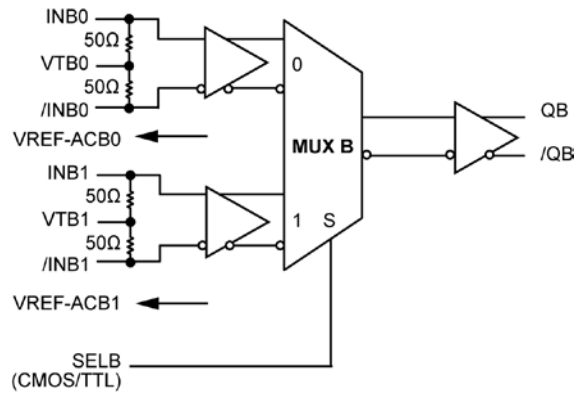
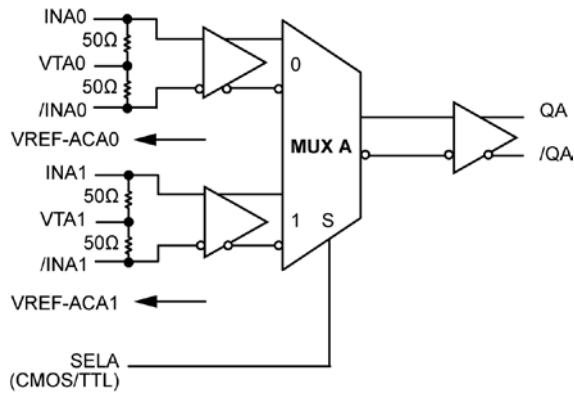

Truth Table

| SEL | Q |
|-----|------------------|
| 0 | IN0 Input Select |
| 1 | IN1 Input Select |

Ordering Information⁽¹⁾

| Part Number | Package Type | Operating Range | Package Marking | Lead Finish |
|-----------------------------|--------------|-----------------|--|----------------|
| SY89853UMG | QFN-32 | Industrial | SY89853U with Pb-Free bar-line indicator | NiPdAu Pb-Free |
| SY89853UMGTR ⁽²⁾ | QFN-32 | Industrial | SY89853U with Pb-Free bar-line indicator | NiPdAu Pb-Free |

Notes:

- Contact factory for die availability. Dice are guaranteed at T_A = 25°C, DC Electricals only.
- Tape and Reel.

Pin Configuration

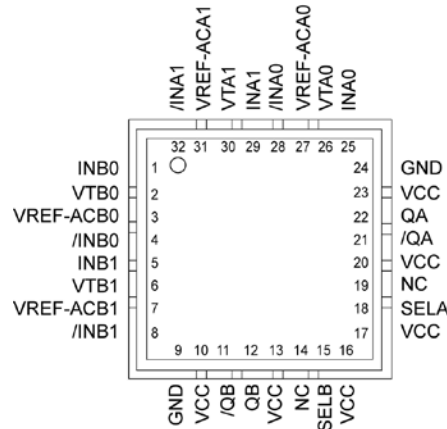

32-Pin QFN

Pin Description

| Pin Number | Pin Name | Pin Function |
|-----------------------------------|---|--|
| 25, 28, 29, 32 1, 4 5, 8 | INA0, /INA0, INA1, /INA1, INB0, /INB0, INB1, /INB1 | Differential Inputs: These input pairs are the differential signal inputs to the device. Inputs accept AC- or DC-coupled signals as small as 100mV. Each pin of a pair internally terminates to a VT pin through 50Ω. Note that these inputs will default to an indeterminate state if left open. Connecting one input to VCC and the complementary input-to-GND through 1kΩ resistor can terminate unused differential input pairs. The VT pin is to be left open in this configuration. Please refer to the “Input Interface Applications” section for more details. |
| 10, 13, 16, 17, 20, 23 | VCC | Positive power supply. Bypass with 0.1μF//0.01μF low ESR capacitors. The 0.01μF capacitor should be as close to VCC pin as possible. |
| 14, 19 | NC | Not connected. |
| 18 15 | SELA, SELB | Bank A and Bank B Input Channel Select (TTL/CMOS): These TTL/CMOS-compatible inputs select the inputs to the multiplexers. These inputs are internally connected to a 25kΩ pull-up resistor and will default to logic HIGH state if left open. |
| 22, 21 12, 11 | QA, /QA, QB, /QB | Differential Outputs: These LVPECL output pairs are the outputs of the device. They are a logic function of the INA0, INA1, INB0, INB1 and SELA and SELB inputs. Please refer to the “Truth Table” below for details. |
| 26, 30 2, 6 | VTA0, VTA1 VTB0, VTB1 | Input Termination Center-Tap: Each side of the differential input pair terminates to a VT pin. The VTA0, VTA1, VTB0, VTB1 pins provide a center-tap to a termination network for maximum interface flexibility. See “Input Interface Applications” section for details. |
| 27 31 3 7 | VREF-ACA0, VREF-ACA1, VREF-ACB0, VREF-ACB1 | Reference Voltages: These reference voltage outputs are equivalent to V _{CC} -1.2V. They are used for AC-coupled inputs. Connect VREF-AC directly to the VT pin and bypass with 0.01μF low ESR capacitor to V _{CC} . See “Input Interface Applications” section. Maximum sink/source current is ±1.5mA. |
| 9, 24 | GND, Exposed Pad | Ground: Ground pins and exposed pad must be connected to the same ground plane. |

Absolute Maximum Ratings⁽¹⁾

| | |
|--|-------------------|
| Supply Voltage (V_{CC}) | -0.5V to +4.0V |
| Input Voltage (V_{IN}) | -0.5V to V_{CC} |
| LVPECL Output Current (I_{OUT}) | |
| Continuous | ± 50 mA |
| Surge | ± 100 mA |
| Termination Current | |
| Source or Sink Current on V_T | ± 50 mA |
| Input Current | |
| Source or Sink Current on IN, /IN | ± 50 mA |
| Current (V_{REF-AC}) | |
| Source or Sink Current on V_{REF-AC} | ± 2 mA |
| Lead Temperature (soldering, 20sec.) | 260°C |
| Storage Temperature (T_s) | -65°C to +150°C |

Operating Ratings⁽²⁾

| | |
|---|--------------------|
| Supply Voltage (V_{CC}) | +2.375V to +2.625V |
| | +3.0V to +3.6V |
| Ambient Temperature (T_A) | -40°C to +85°C |
| Package Thermal Resistance ⁽³⁾ | |
| QFN (θ_{JA}) | |
| Still-Air | 35°C/W |
| 500lfpm | 28°C/W |
| QFN (ψ_{JB}) | |
| Junction-to-Board | 16°C/W |

DC Electrical Characteristics⁽⁴⁾

$T_A = -40^\circ\text{C}$ to $+85^\circ\text{C}$, unless otherwise noted.

| Symbol | Parameter | Condition | Min | Typ | Max | Units |
|----------------|---|--|----------------|----------------|----------------|----------|
| V_{CC} | Power Supply | $V_{CC} = 2.5\text{V}$ $V_{CC} = 3.3\text{V}$ | 2.375 3.0 | 2.5 3.3 | 2.625 3.6 | V V |
| I_{CC} | Power Supply Current | No load, max. V_{CC} . | | 65 | 85 | mA |
| R_{IN} | Input Resistance (IN-to- V_T) | | 45 | 50 | 55 | Ω |
| R_{DIFF_IN} | Differential Input Resistance (IN-to-/IN) | | 90 | 100 | 110 | Ω |
| V_{IH} | Input High Voltage (IN, /IN) | Note 5 | $V_{CC} - 1.6$ | | V_{CC} | V |
| V_{IL} | Input Low Voltage (IN, /IN) | | 0 | | $V_{IH} - 0.1$ | V |
| V_{IN} | Input Voltage Swing (IN-to-/IN) | See Figure 1a. | 0.1 | | 1.7 | V |
| V_{DIFF_IN} | Differential Input Voltage Swing IN - /IN | See Figure 1b. | 0.2 | | | V |
| V_{T_IN} | Maximum Input Voltage (IN-to- V_T) | | | | 1.28 | V |
| V_{REF-AC} | Output Reference Voltage | | $V_{CC} - 1.3$ | $V_{CC} - 1.2$ | $V_{CC} - 1.1$ | V |

Notes:

1. Permanent device damage may occur if absolute maximum ratings are exceeded. This is a stress rating only and functional operation is not implied at conditions other than those detailed in the operational sections of this data sheet. Exposure to absolute maximum ratings conditions for extended periods may affect device reliability.
2. The data sheet limits are not guaranteed if the device is operated beyond the operating ratings.
3. Package thermal resistance assumes exposed pad is soldered (or equivalent) to the devices most negative potential on the PCB. θ_{JA} and ψ_{JB} values are determined for a 4-layer board in still-air, unless otherwise stated.
4. The circuit is designed to meet the DC specifications shown in the above table after thermal equilibrium has been established.
5. V_{IH} (min) not lower than 1.2V.

LVPECL Outputs DC Electrical Characteristics⁽⁵⁾

$V_{CC} = 2.5V \pm 5\%$ or $3.3V \pm 10\%$; $R_L = 50\Omega$ to $V_{CC}-2V$; $T_A = -40^\circ C$ to $+85^\circ C$, unless otherwise noted.

| Symbol | Parameter | Condition | Min | Typ | Max | Units |
|----------------|--|----------------|----------------|------|----------------|-------|
| V_{OH} | Output High Voltage (Q, /Q) | | $V_{CC}-1.145$ | | $V_{CC}-0.895$ | V |
| V_{OL} | Output Low Voltage (Q, /Q) | | $V_{CC}-1.945$ | | $V_{CC}-1.695$ | V |
| V_{OUT} | Output Voltage Swing (Q, /Q) | See Figure 1a. | 400 | 800 | | mV |
| $V_{DIFF-OUT}$ | Differential Output Voltage Swing (Q, /Q) | See Figure 1b. | 800 | 1600 | | mV |

LVTTL/CMOS DC Electrical Characteristics⁽⁵⁾

$V_{CC} = 2.5V \pm 5\%$ or $3.3V \pm 10\%$; $T_A = -40^\circ C$ to $+85^\circ C$, unless otherwise noted.

| Symbol | Parameter | Condition | Min | Typ | Max | Units |
|----------|--------------------|-------------------|------|-----|-----|---------|
| V_{IH} | Input High Voltage | | 2.0 | | | V |
| V_{IL} | Input Low Voltage | | | | 0.8 | V |
| I_{IH} | Input High Current | $V_{IN} = V_{CC}$ | | | 75 | μA |
| I_{IL} | Input Low Current | $V_{IN} = 0.5V$ | -300 | | | μA |

Notes:

5. The circuit is designed to meet the DC specifications shown in the above table after thermal equilibrium has been established.

AC Electrical Characteristics⁽⁶⁾

$V_{CC} = 2.5V \pm 5\%$ or $3.3V \pm 10\%$; $T_A = -40^\circ C$ to $+85^\circ C$, $R_L = 50\Omega$ to $V_{CC} - 2V$, unless otherwise stated.

| Symbol | Parameter | Condition | Min | Typ | Max | Units |
|--------------------|--|--------------------------|-----|-----|-----|-------------------|
| f_{MAX} | Maximum Operating Frequency | NRZ Data | 2.5 | | | Gbps |
| | | Clock, $V_{OUT} > 400mV$ | 2.5 | | | GHz |
| t_{pd} | Propagation Delay IN-to-Q SEL-to-Q | | | | | |
| | | | 160 | 250 | 360 | ps |
| | | | 100 | 260 | 400 | ps |
| t_{pd} Tempco | Differential Propagation Delay Temperature Coefficient | | | 143 | | fs/°C |
| t_{SKEW} | Input-to-Input Skew (Within-bank) Bank-to-Bank Skew | Note 7 | | 10 | 20 | ps |
| | | Note 8 | | 12 | 25 | ps |
| t_{JITTER} | Data Random Jitter (RJ) Deterministic Jitter (DJ) | Note 9 | | | 1 | ps _{RMS} |
| | | Note 10 | | | 10 | ps _{PP} |
| | Clock Cycle-to-Cycle Jitter Total Jitter (TJ) | Note 11 | | | 1 | ps _{RMS} |
| | | Note 12 | | | 10 | ps _{PP} |
| | Crosstalk-Induced Jitter Channel-to-Channel (Within-bank) | Note 13, within-bank | | | 0.7 | ps _{RMS} |
| | | | | | | |
| t_r, t_f | Output Rise/Fall Time (20% to 80%) | At full output swing. | 50 | 100 | 180 | ps |

Notes:

6. High-speed AC parameters are guaranteed by design and characterization. V_{IN} swing $\geq 100mV$, unless otherwise stated.
7. Input-to-input skew is the difference in time between two inputs to the output within a bank.
8. Bank-to-bank skew is the difference in time from input to the output between banks.
9. Random jitter is measured with a K28.7 character pattern, measured at $<f_{MAX}$.
10. Deterministic jitter is measured at 2.5Gbps with both K28.5 and $2^{23}-1$ PRBS pattern.
11. Cycle-to-cycle jitter definition: the variation of periods between adjacent cycles, $T_n - T_{n-1}$ where T is the time between rising edges of the output signal.
12. Total jitter definition: with an ideal clock input of frequency $<f_{MAX}$, no more than one output edge in 10^{12} output edges will deviate by more than the specified peak-to-peak jitter value.
13. Crosstalk is measured at the output while applying two similar differential clock frequencies that are asynchronous with respect to each other at the inputs.

Typical Operating Characteristics

$V_{CC} = 3.3V \pm 10\%$; $T_A = -40^\circ C$ to $+85^\circ C$, $R_L = 50\Omega$ to $V_{CC} - 2V$, unless otherwise stated.

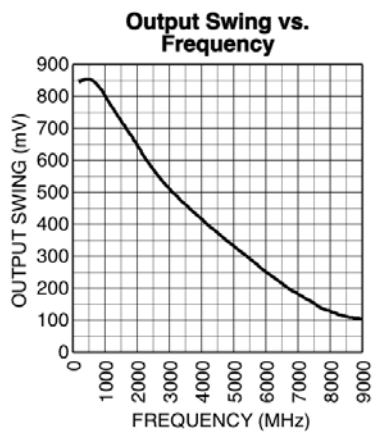

Functional Characteristics

$V_{CC} = 3.3V \pm 10\%$; $T_A = -40^{\circ}C$ to $+85^{\circ}C$, $R_L = 50\Omega$ to $V_{CC}-2V$, unless otherwise stated.

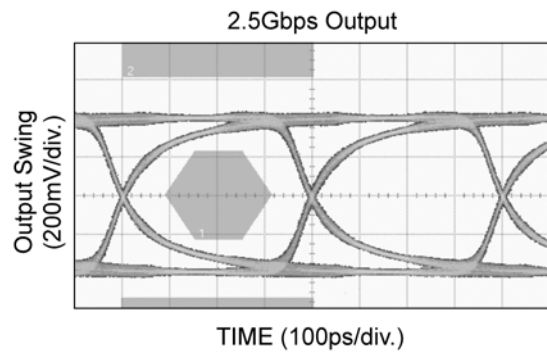
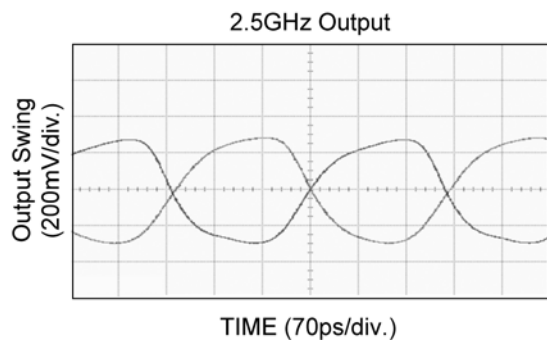
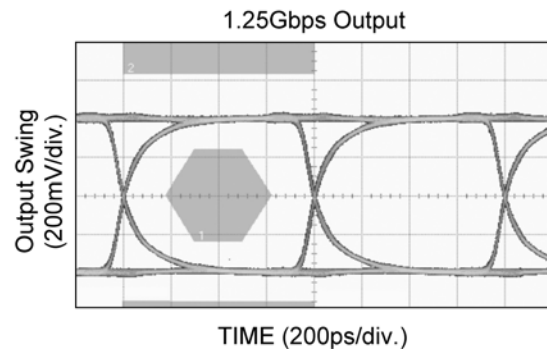
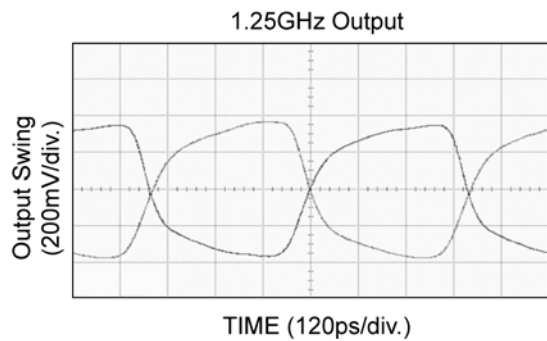
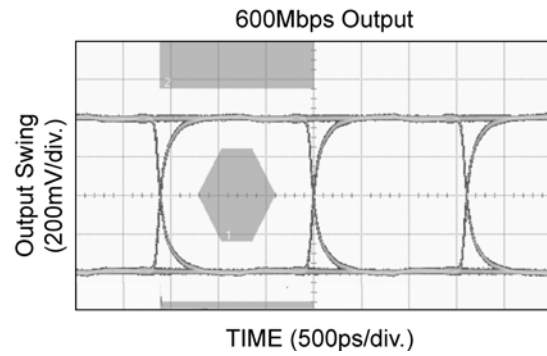
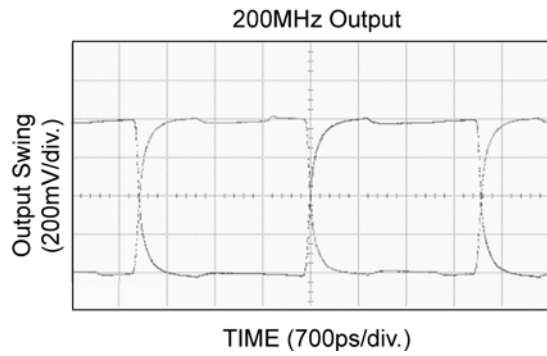

Single-Ended and Differential Swings

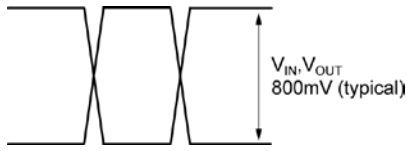

Figure 1a. Single-Ended Voltage Swing

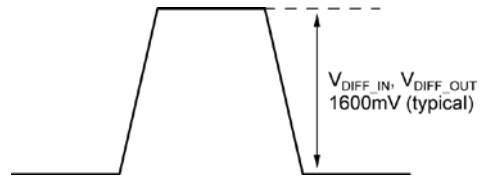
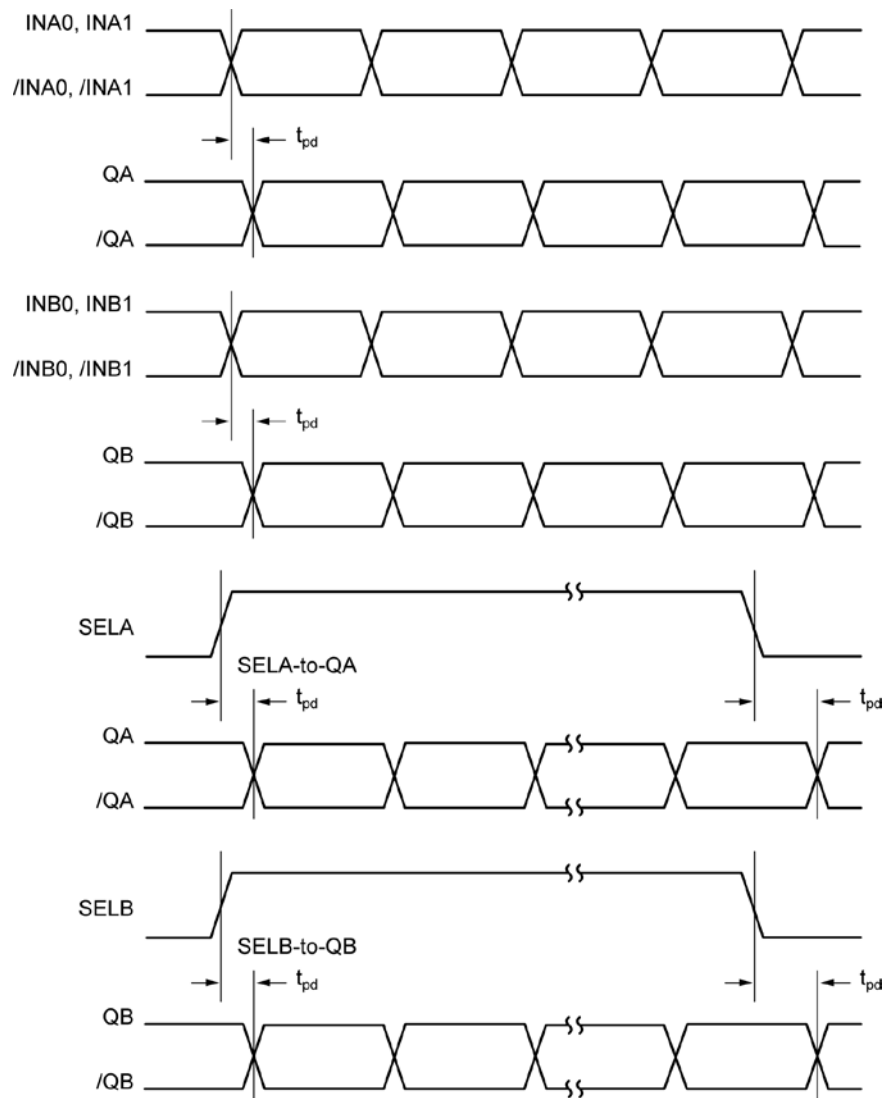

Figure 1b. Differential Voltage Swing

Timing Diagram



Input and Output Stages

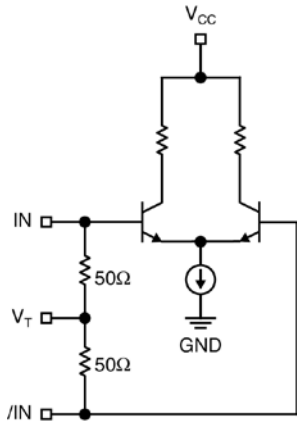

Figure 2a. Simplified Differential Input Stage

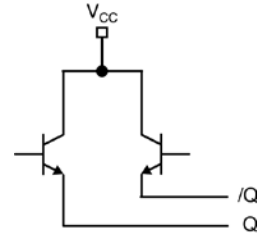

Figure 2b. Simplified LVPECL Output Stage

Input Interface Applications

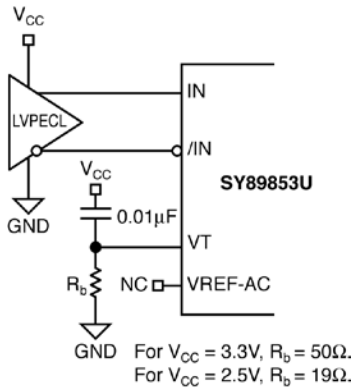

Figure 3a. LVPECL Interface (DC-Coupled)

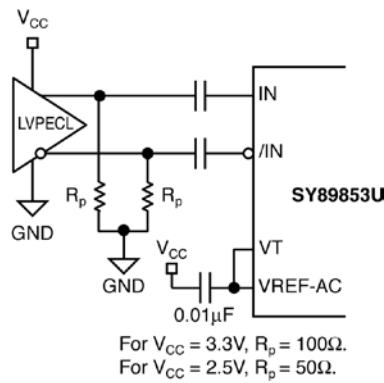

Figure 3b. LVPECL Interface (AC-Coupled)

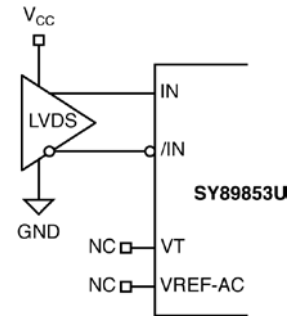
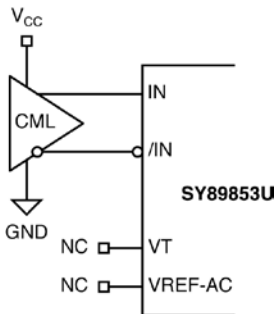

Figure 3c. LVDS Interface



option: may connect V_T to V_{CC} .

Figure 3d. CML Interface (DC-Coupled)

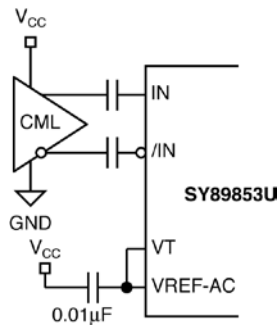
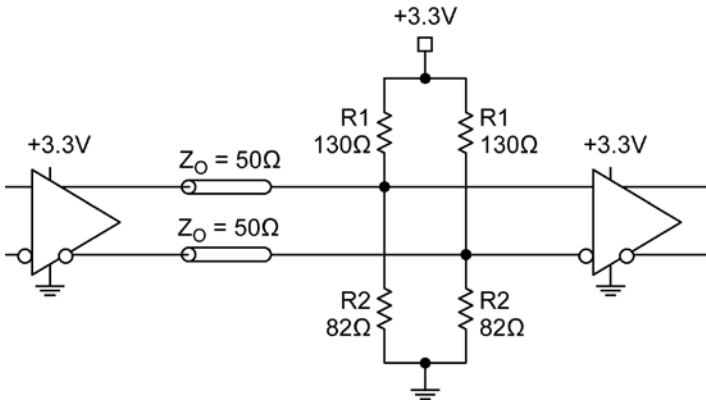

Figure 3e. CML Interface (AC-Coupled)

Output Interface Applications

LVPECL has high input impedance, very low output (open emitter) impedance, and small signal swing, which result in low EMI. LVPECL is ideal for driving 50Ω and 100Ω controlled impedance transmission lines. There are different techniques for terminating

LVPECL outputs: Parallel Termination Thevenin-Equivalent, Parallel Termination (3-resistor), and AC-coupled termination. Unused output pairs may be left floating; however, single-ended outputs must be terminated or balanced.



Note:

1. For a 2.5V system, R1 = 250Ω, R2 = 62.5 Ω.
2. For a 3.3V system, R1 = 130Ω, R2 = 82Ω.

Figure 4a. Parallel Thevenin-Equivalent Termination

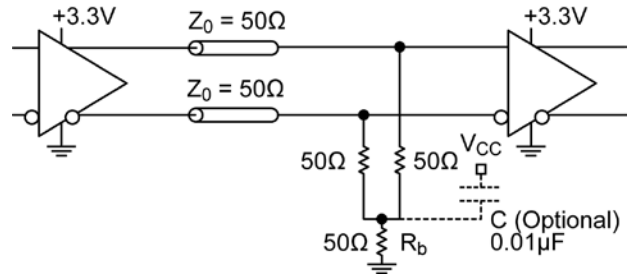

Note:

1. For a 2.5V system, R_b = 19Ω.
2. For a 3.3V system, R_b = 50Ω.

Figure 4b. Parallel Termination (3-Resistor)

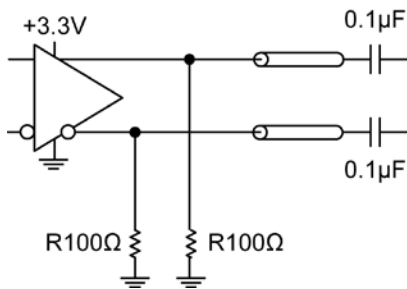

Note:

For a 2.5V system, R = 50Ω.

Figure 4c. AC-Coupled Termination

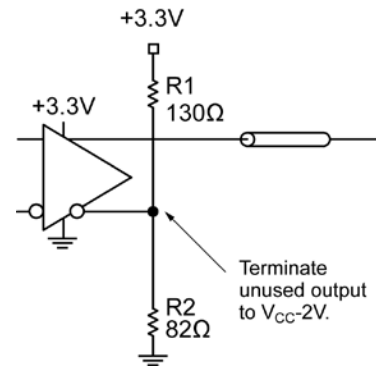

Note:

For a 2.5V system, R1 = 250Ω, R2 = 62.5 Ω.

Figure 4d. Parallel Thevenin-Equivalent Termination

Related Product and Support Documentation

| Part Number | Function | Data Sheet Link |
|---------------|--|--|
| SY58026U | 5Gbps Dual 2 :1 400mV LVPECL MUX with Internal Termination | www.micrel.com/product-info/products/sy58026u.shtml |
| HBW Solutions | New Products and Applications | www.micrel.com/product-info/products/solutions.shtml |

Package Information

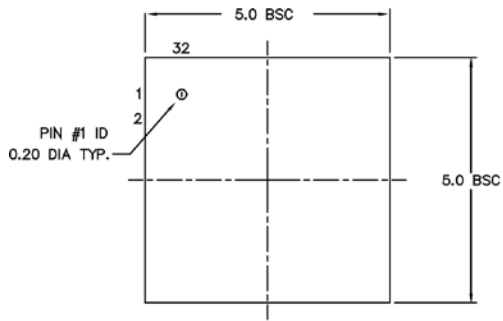

TOP VIEW

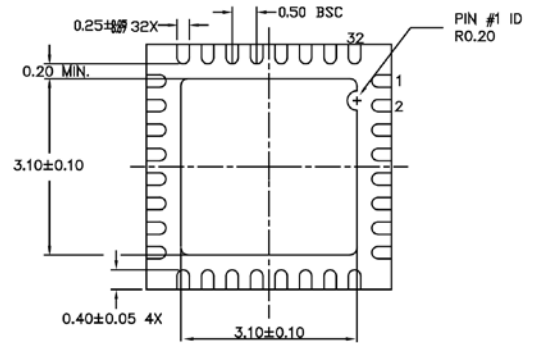

BOTTOM VIEW

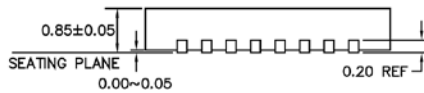

SIDE VIEW

NOTE:

1. ALL DIMENSIONS ARE IN MILLIMETERS.
2. MAX. PACKAGE WARPAGE IS 0.05 mm.
3. MAXIMUM ALLOWABLE BURRS IS 0.076 mm IN ALL DIRECTIONS.
4. PIN #1 ID ON TOP WILL BE LASER/INK MARKED.

32-Pin QFN

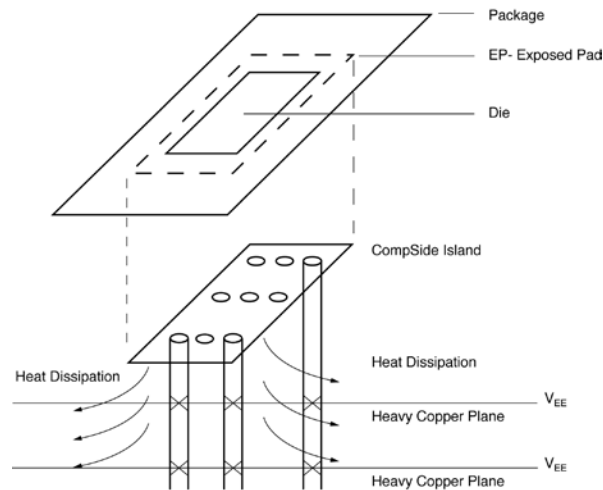

**PCB Thermal Consideration for 32-Pin QFN Package
(Always solder, or equivalent, the exposed pad to the PCB)**

Packages Notes:

1. Package meets Level 2 Moisture Sensitivity Classification.
2. All parts are dry-packed before shipment.
3. Exposed pads must be soldered to a ground for proper thermal management.

MICREL, INC. 2180 FORTUNE DRIVE SAN JOSE, CA 95131 USA
TEL +1 (408) 944-0800 FAX +1 (408) 474-1000 WEB <http://www.micrel.com>

The information furnished by Micrel in this data sheet is believed to be accurate and reliable. However, no responsibility is assumed by Micrel for its use. Micrel reserves the right to change circuitry and specifications at any time without notification to the customer.

Micrel Products are not designed or authorized for use as components in life support appliances, devices or systems where malfunction of a product can reasonably be expected to result in personal injury. Life support devices or systems are devices or systems that (a) are intended for surgical implant into the body or (b) support or sustain life, and whose failure to perform can be reasonably expected to result in a significant injury to the user. A Purchaser's use or sale of Micrel Products for use in life support appliances, devices or systems is a Purchaser's own risk and Purchaser agrees to fully indemnify Micrel for any damages resulting from such use or sale.

© 2005 Micrel, Incorporated.

Looking for pricing, stock, or lifecycle information?

Click below to explore more details on WIN SOURCE:

- ⊖ [View SY89853UMG-TR on WIN SOURCE](#)
- ⊖ [Microchip Technology](#) Information

Optimize Your Supply Chain with WIN SOURCE Solutions

- ✓ Global Sourcing Solution
- ✓ Obsolete Management
- ✓ Cost Control Management
- ✓ Shortage Management
- ✓ Alternative Solution
- ✓ Excess Inventory Management