



THE DATASHEET OF RT9712AGF



90mΩ, 1A/1.5A High-Side Dual Power Switches with Flag

General Description

The RT9712 power-distribution switches are designed to fulfill the applications in heavy capacitive loads and short-circuit situations. The device incorporates two 90mΩ N-MOSFET power switches to fit power distribution systems requiring multiple power switches in a single package. During switching process, an internal charge pump is designed to provide the gate drive for the purpose of power-switch rise times and fall times controlling to minimize the current surges. The charge pump can operate in supply voltage as low as 2.7V and needs no external components.

If the output load exceeds the current-limit threshold or a short-circuit occurs. The RT9712 series pull the overcurrent (FLGx) logic output low by switching into the constant-current mode to maintain the output current in a safe level, A thermal protection circuit turns off the switch to prevent the device from damage when power dissipation is increased by continuous heavy overloads and short-circuits in the switch and finally cause the rise of the junction temperature. The device automatically recovers when it has sufficiently cooled down. The RT9712A/B are designed for the current limit at typically 2A and RT9712C/D are designed for the current limit at typically 1.5A. Internal circuitry controls the switch to remain off until valid input voltage is presented.

Pin Configurations

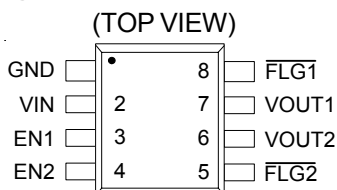

RT9712A/C

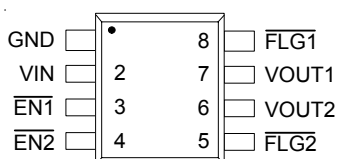

RT9712B/D

SOP-8/MSOP-8

Features

- 90mΩ N-MOSFET Switch
- Operating Voltage Range : 2.7V to 5.5V
- Reverse Blocking Current
- Under Voltage Lockout
- Deglitched Fault Report (FLGx)
- Thermal Protection with Foldback
- Over Current Protection
- Short Circuit Protection
- UL Approved—E219878 
- Nemko Approved-NO49352
- RoHS Compliant and Halogen Free

Applications

- USB Peripherals
- Notebook PCs

Ordering Information

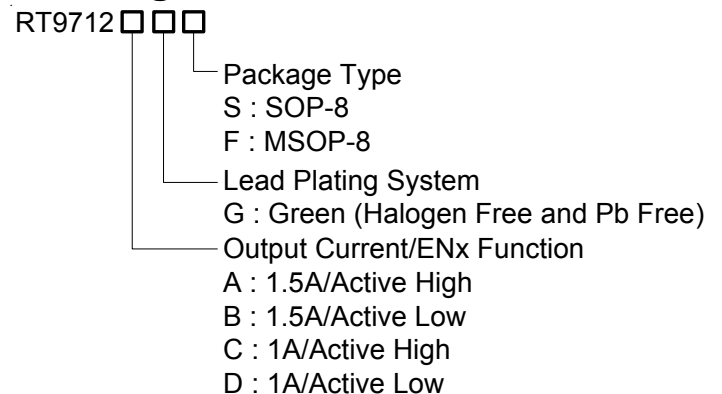

Note :

Richtek products are :

- ▶ RoHS compliant and compatible with the current requirements of IPC/JEDEC J-STD-020.
- ▶ Suitable for use in SnPb or Pb-free soldering processes.

Marking Information

For marking information, contact our sales representative directly or through a Richtek distributor located in your area.

Typical Application Circuit

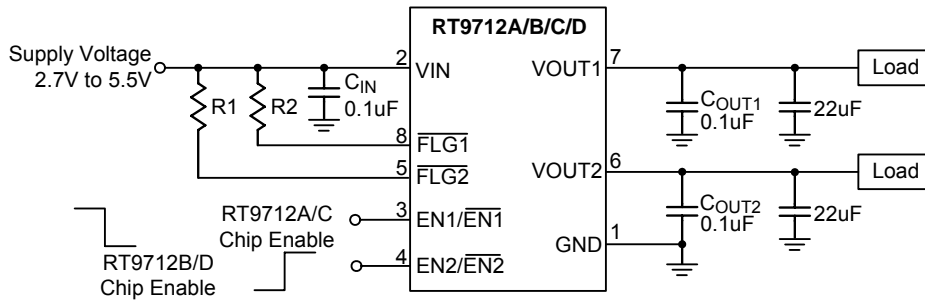

Note : R1, R2 : Pull-Up Resistance (10k to 100k)

Functional Pin Description

Pin No.		Pin Name	Pin Function
RT9712A/C	RT9712B/D		
1	1	GND	Ground.
2	2	VIN	Input Voltage.
--	3	$\overline{\text{EN1}}$	Chip Enable (Active Low) turns on power switch in VOUT1.
--	4	$\overline{\text{EN2}}$	Chip Enable (Active Low) turns on power switch in VOUT2.
3	--	EN1	Chip Enable (Active High) turns on power switch in VOUT1.
4	--	EN2	Chip Enable (Active High) turns on power switch in VOUT2.
5	5	$\overline{\text{FLG2}}$	Over current or over temperature status output, open-drain output, active low, in VOUT2.
6	6	VOUT2	Power-Switch Output, in VOUT2.
7	7	VOUT1	Power-Switch Output, in VOUT1.
8	8	$\overline{\text{FLG1}}$	Over current or over temperature status output,, open-drain output, active low, in VOUT1.

Function Block Diagram

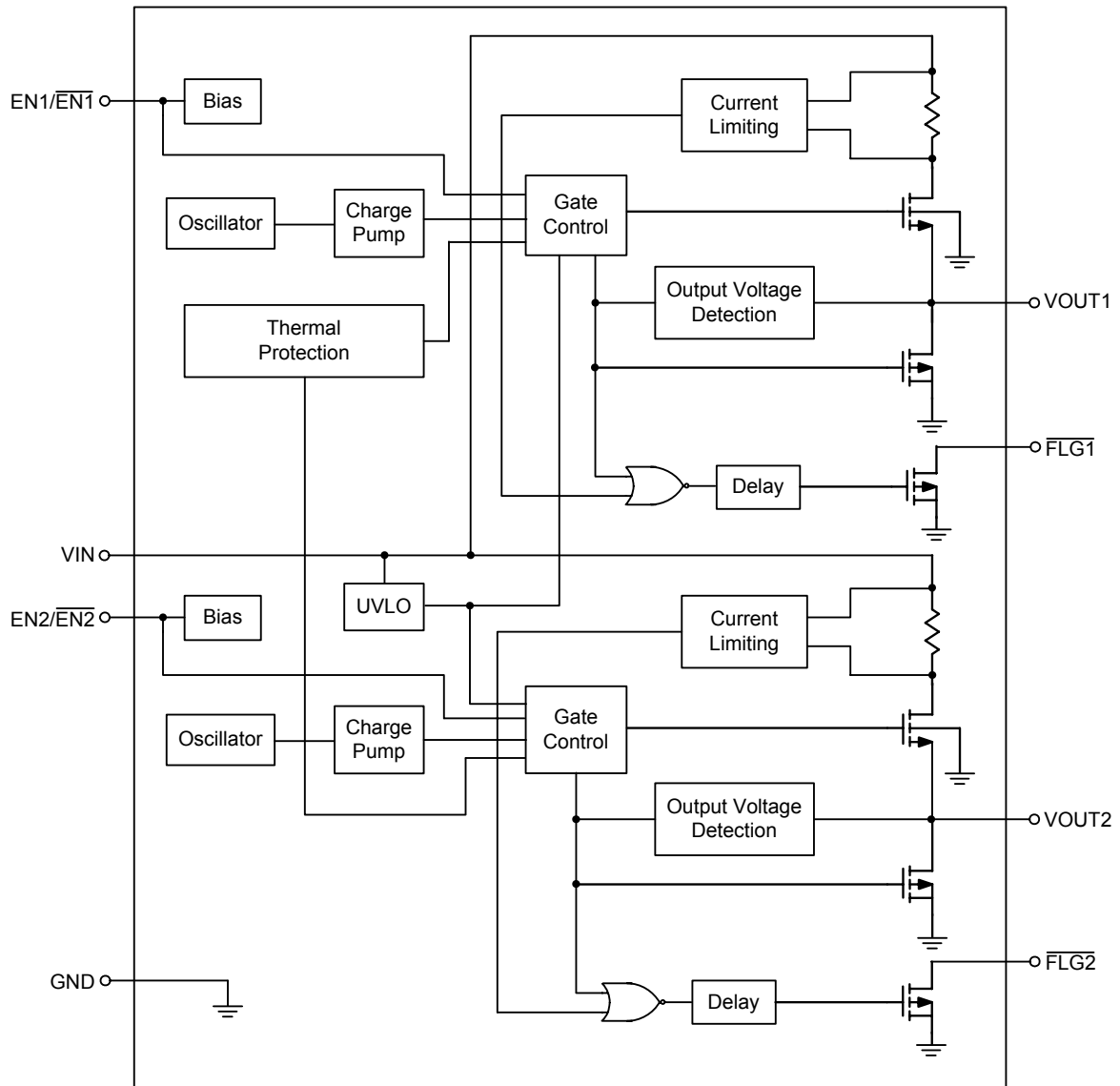

Absolute Maximum Ratings (Note 1)

- Supply Input Voltage, V_{IN} ----- 6V
- EN Voltage ----- -0.3V to 6V
- Power Dissipation, P_D @ $T_A = 25^\circ\text{C}$
 SOP-8/MSOP-8 ----- 469mW
- Package Thermal Resistance (Note 2)
 SOP-8/MSOP-8, θ_{JA} ----- 160°C/W
- Junction Temperature ----- 150°C
- Lead Temperature (Soldering, 10 sec.) ----- 260°C
- Storage Temperature Range ----- -65°C to 150°C
- ESD Susceptibility (Note 3)
 HBM (Human Body Model) ----- 2kV

Recommended Operating Conditions (Note 4)

- Supply Input Voltage, V_{IN} ----- 2.7V to 5.5V
- EN Voltage ----- 0V to 5.5V
- Junction Temperature Range ----- -40°C to 100°C
- Ambient Temperature Range ----- -40°C to 85°C

Electrical Characteristics

($V_{IN} = 5V$, $C_{IN} = 1\mu\text{F}$, $C_{OUT1} = C_{OUT2} = 10\mu\text{F}$, $T_A = 25^\circ\text{C}$, unless otherwise specified)

Parameter		Symbol	Test Conditions	Min	Typ	Max	Unit
Input Quiescent Current		I_Q	Switch On, R_{LOAD} Open	--	70	90	μA
Input Shutdown Current		I_{SHDN}	Switch Off, R_{LOAD} Open	--	0.1	1	
Switch On Resistance	RT9712A/B	$R_{DS(ON)}$	$I_{OUTx} = 1.3A$, $V_{IN} = 5V$, Each Channel	---	90	110	$\text{m}\Omega$
	RT9712C/D			$I_{OUTx} = 1A$, $V_{IN} = 5V$, Each Channel	--	90	110
Current Limit	RT9712A/B	I_{LIM}	$V_{OUTx} = 4V$	1.5	2	2.8	A
	RT9712C/D			1.1	1.5	2.1	
Short Circuit Fold-back Current	RT9712A/B	I_{SC_FB}	$V_{OUTx} = 0$, Measured Prior to Thermal Shutdown	--	1.4	--	A
	RT9712C/D			--	1	--	
ENx/ $\overline{\text{ENx}}$ Threshold	Logic-Low Voltage	V_{IL}	$V_{IN} = 2.7V$ to $5.5V$	--	--	0.8	V
	Logic-High Voltage	V_{IH}	$V_{IN} = 2.7V$ to $5.5V$	2	--	--	
ENx/ $\overline{\text{ENx}}$ Input Current		$I_{ENx/\overline{\text{ENx}}}$	$V_{ENx/\overline{\text{ENx}}} = 0V$ to $5.5V$	--	0.01	0.1	μA
Output Leakage Current		$I_{LEAKAGE}$	$V_{ENx} = 0V$, $V_{\overline{\text{ENx}}} = 5V$, $R_{LOAD} = 0\Omega$	-	0.5	1	μA
Output Turn-On Rising Time		T_{ON_RISE}	10% to 90% of V_{OUT} Rising	--	175	--	μs
$\overline{\text{FLGx}}$ Output Resistance		$R_{\overline{\text{FLG}}}$	$I_{SINK} = 1\text{mA}$	--	20	--	Ω
$\overline{\text{FLGx}}$ Off Current		$I_{\overline{\text{FLG}}_OFF}$	$V_{\overline{\text{FLGx}}} = 5V$	--	0.01	1	μA
$\overline{\text{FLGx}}$ Delay Time		T_D	From Fault Condition to $\overline{\text{FLG}}$ Assertion	5	12	20	ms

Parameter	Symbol	Test Conditions	Min	Typ	Max	Unit
Shutdown Auto-discharge Resistance	$R_{\text{Discharge}}$	$V_{\text{ENx}} = 0\text{V}, \overline{V_{\text{ENx}}} = 5\text{V}$	--	100	150	Ω
Under Voltage Lockout	V_{UVLO}	V_{IN} Increasing	1.3	1.7	--	V
Under Voltage Hysteresis	ΔV_{UVLO}	V_{IN} Decreasing	--	0.1	--	V
Thermal Shutdown Protection	T_{SD}	$V_{\text{OUTx}} > 1\text{V}$	--	120	--	$^{\circ}\text{C}$
Thermal Shutdown Protection		$V_{\text{OUTx}} < 1\text{V}$	--	100	--	$^{\circ}\text{C}$
Thermal Shutdown Hysteresis			--	20	--	$^{\circ}\text{C}$

Note 1. Stresses beyond those listed “Absolute Maximum Ratings” may cause permanent damage to the device. These are stress ratings only, and functional operation of the device at these or any other conditions beyond those indicated in the operational sections of the specifications is not implied. Exposure to absolute maximum rating conditions may affect device reliability.

Note 2. θ_{JA} is measured at $T_{\text{A}} = 25^{\circ}\text{C}$ on a low effective thermal conductivity single-layer test board per JEDEC 51-3.

Note 3. Devices are ESD sensitive. Handling precaution is recommended.

Note 4. The device is not guaranteed to function outside its operating conditions.

Typical Operating Characteristics

On Resistance vs. Input Voltage

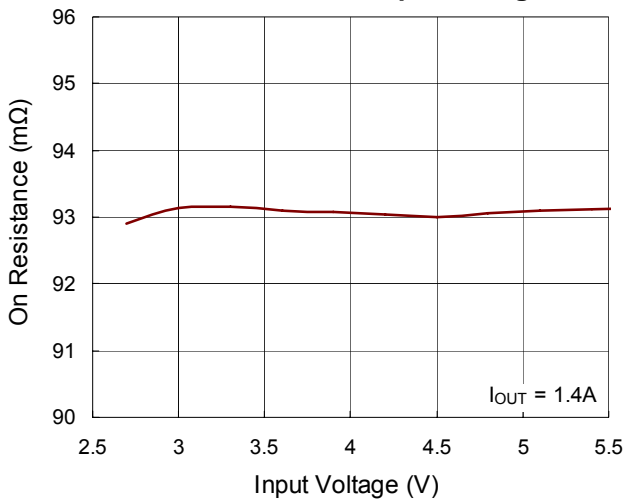

On Resistance vs. Temperature

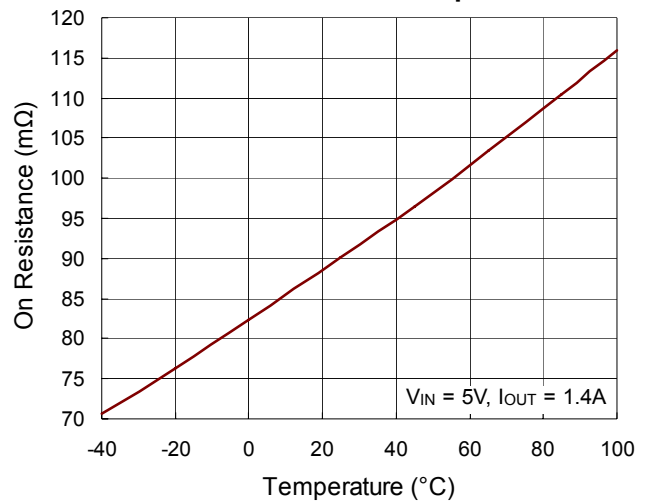

Quiescent Current vs. Input Voltage

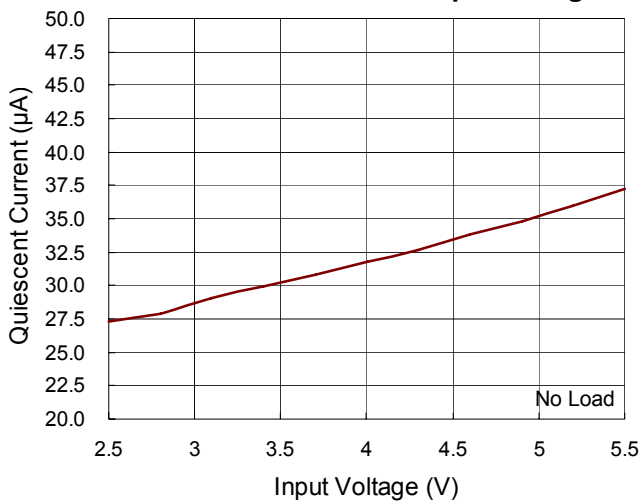

Quiescent Current vs. Temperature

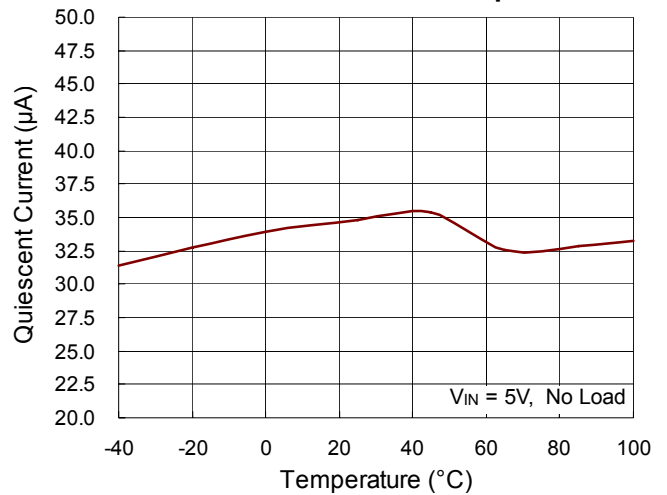

Shutdown Current vs. Input Voltage

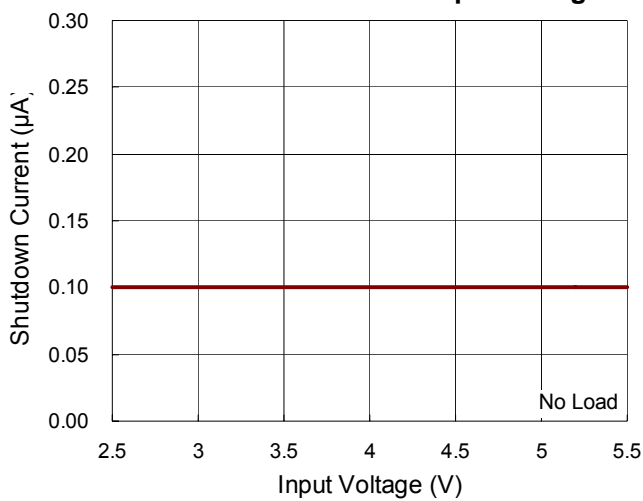

Shutdown Current vs. Temperature

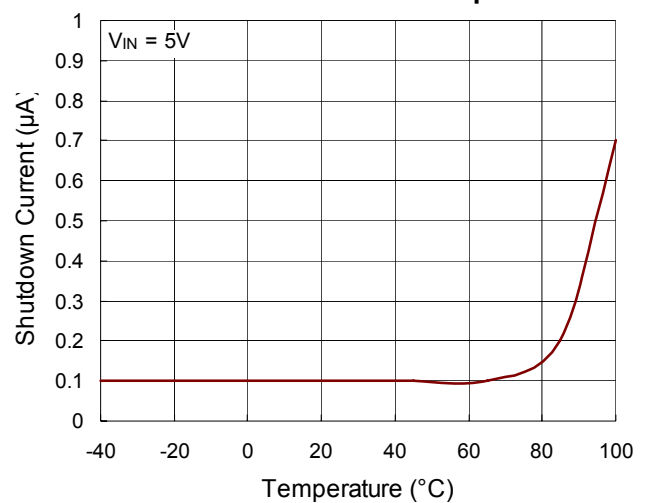

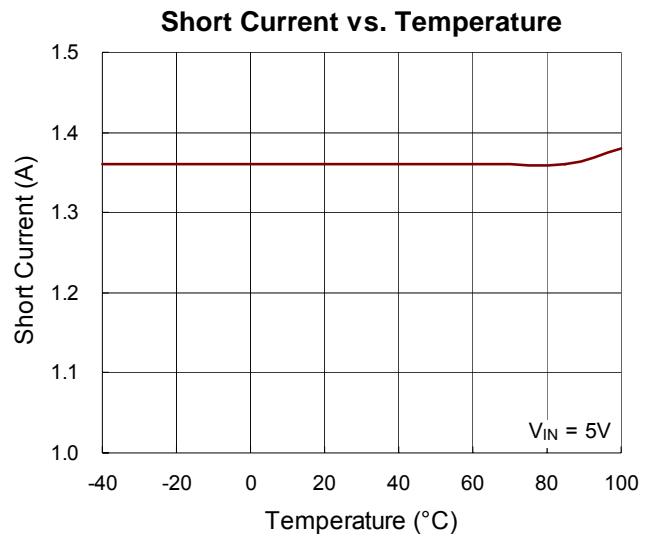
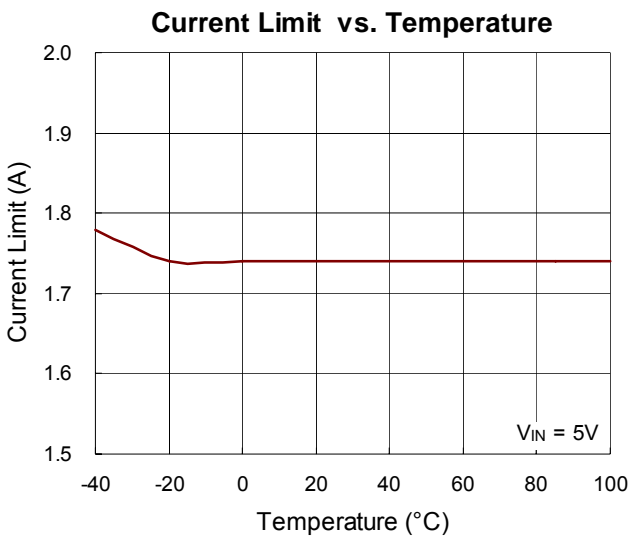
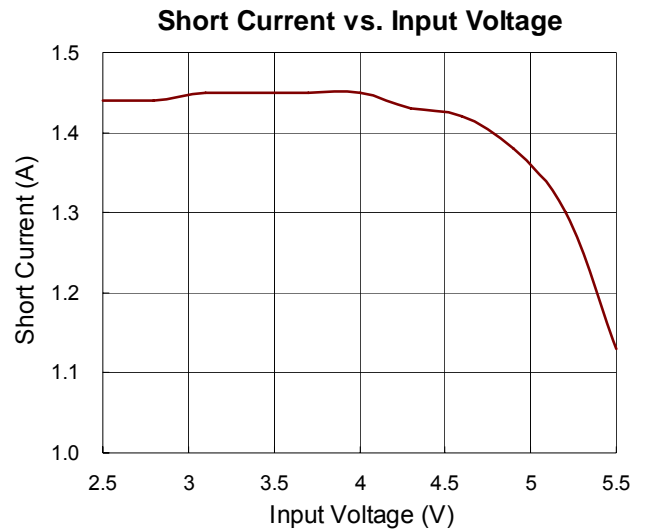
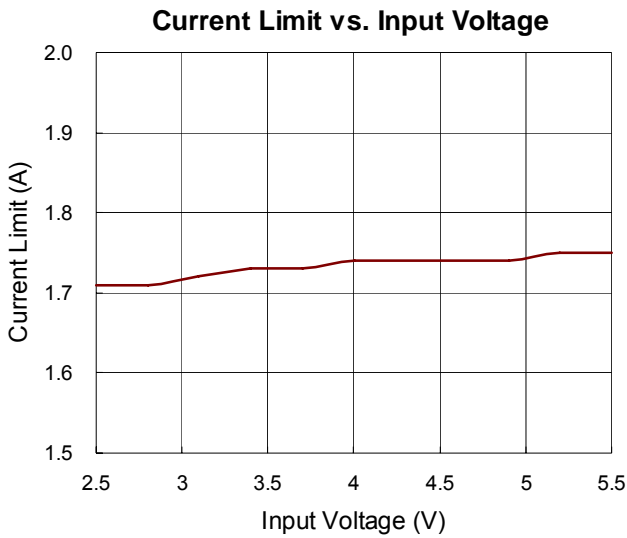
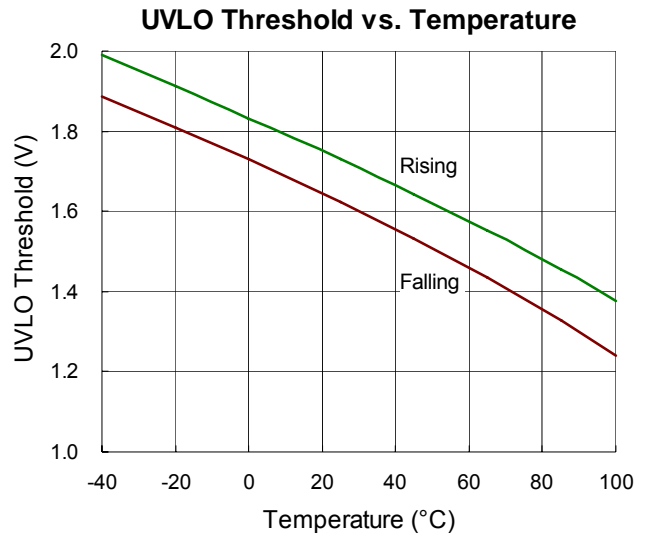
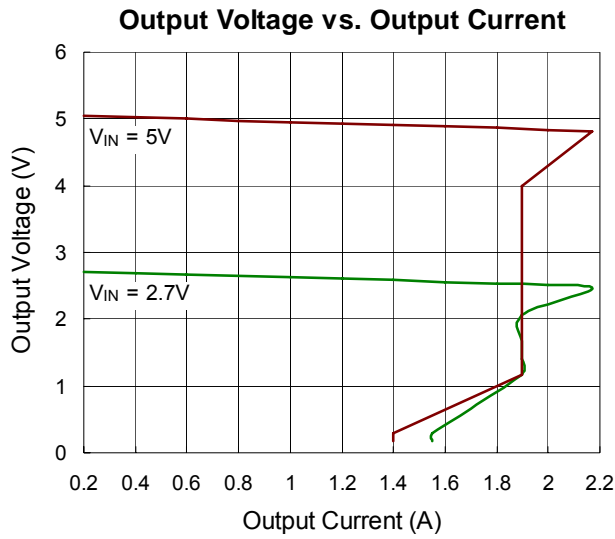

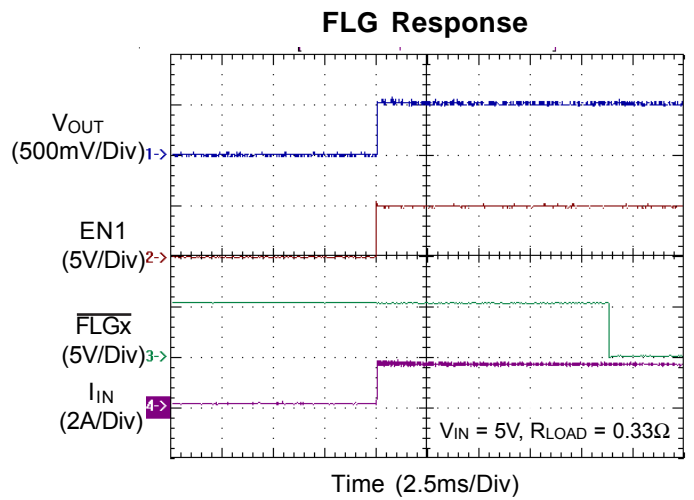
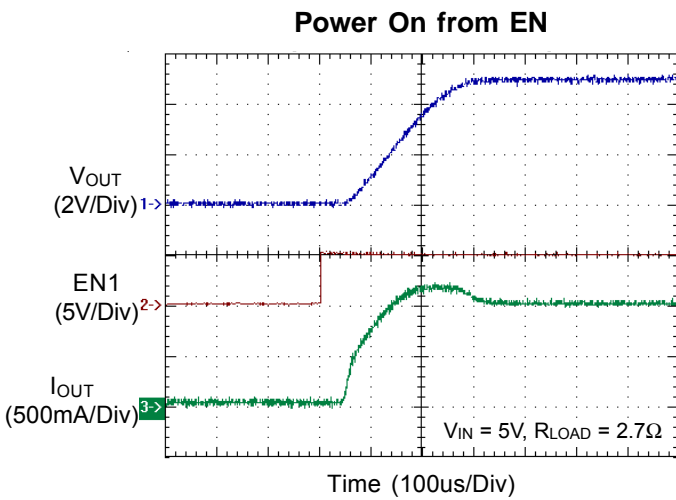
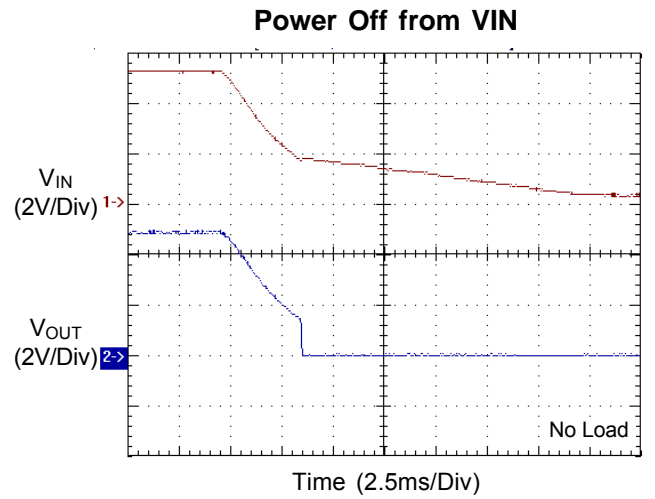
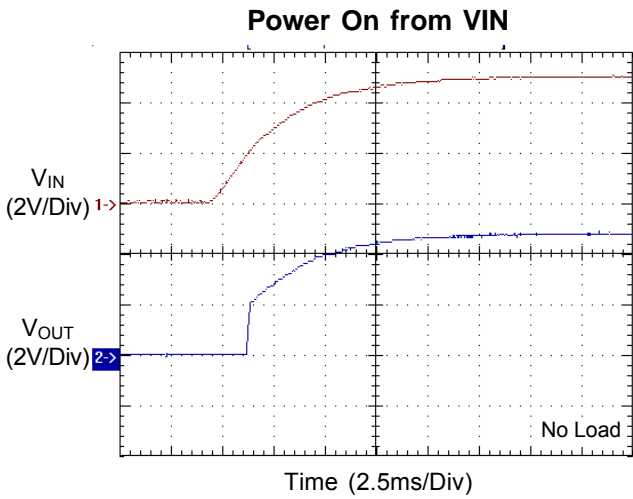
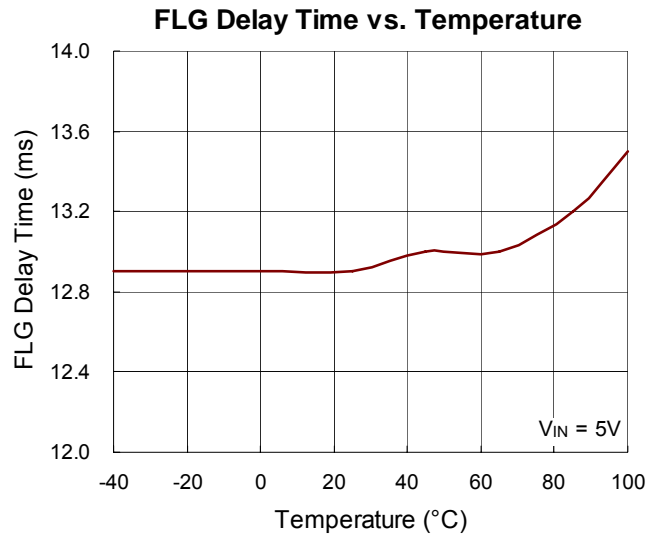
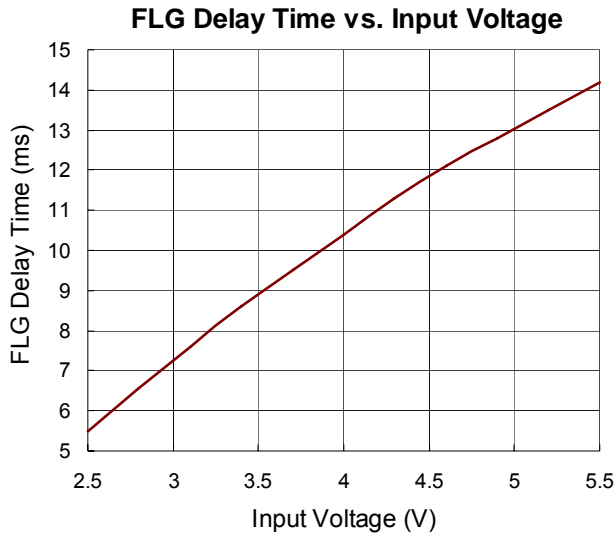

Applications Information

The RT9712A/B/C/D are dual N-MOSFET high-side power switch with enable input, optimized for self-powered and bus-powered Universal Serial Bus (USB) applications. The RT9712 series are equipped with a charge pump circuitry to drive the internal N-MOSFET switch; the switch's low $R_{DS(ON)}$, 90m Ω , meets USB voltage drop requirements; and a flag output is available to indicate fault conditions to the local USB controller.

Input and Output

V_{IN} (input) is the power source connection to the internal circuitry and the drain of the MOSFET. V_{OUT} (output) is the source of the MOSFET. In a typical application, current flows through the switch from V_{IN} to V_{OUT} toward the load. If V_{OUT} is greater than V_{IN} , current will flow from V_{OUT} to V_{IN} since the MOSFET is bidirectional when on.

Unlike a normal MOSFET, there is no parasitic body diode between drain and source of the MOSFET, the RT9712A/B/C/D prevents reverse current flow if V_{OUT} is externally forced to a higher voltage than V_{IN} when the chip is disabled ($V_{EN} < 0.8V$ or $V_{\overline{EN}} > 2V$).

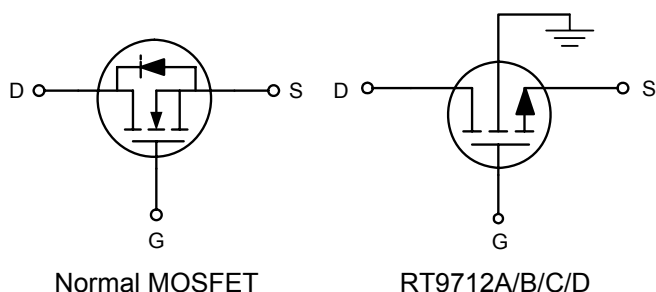

Chip Enable Input

The switch will be disabled when the $\overline{EN/EN}$ pin is in a logic low/high condition. During this condition, the internal circuitry and MOSFET will be turned off, reducing the supply current to 0.1 μ A typical. Floating the $\overline{EN/EN}$ may cause unpredictable operation. \overline{EN} should not be allowed to go negative with respect to GND. The $\overline{EN/EN}$ pin may be directly tied to V_{IN} (GND) to keep the part on.

Soft Start for Hot Plug-In Applications

In order to eliminate the upstream voltage droop caused by the large inrush current during hot-plug events, the "soft-start" feature effectively isolates the power source from extremely large capacitive loads, satisfying the USB voltage droop requirements.

Fault Flag

The RT9712 series provides a \overline{FLG} signal pin which is an N-Channel open drain MOSFET output. This open drain output goes low when current limit or the die temperature exceeds 120°C approximately. The \overline{FLG} output is capable of sinking a 10mA load to typically 200mV above ground. The \overline{FLG} pin requires a pull-up resistor, this resistor should be large in value to reduce energy drain. A 100k Ω pull-up resistor works well for most applications. In the case of an over-current condition, \overline{FLG} will be asserted only after the flag response delay time, t_D , has elapsed. This ensures that \overline{FLG} is asserted only upon valid over-current conditions and that erroneous error reporting is eliminated.

For example, false over-current conditions may occur during hot-plug events when extremely large capacitive loads are connected and causes a high transient inrush current that exceeds the current limit threshold. The \overline{FLG} response delay time t_D is typically 12ms.

Under-Voltage Lockout

Under-voltage lockout (UVLO) prevents the MOSFET switch from turning on until the input voltage exceeds approximately 1.7V. If input voltage drops below approximately 1.3V, UVLO turns off the MOSFET switch. Under-voltage detection functions only when the switch is enabled.

Current Limit and Short-Circuit Protection

The current limit circuitry prevents damage to the MOSFET switch and the hub downstream port. Besides, in order to prevent the miss-trigger because of USB plug in and other inrush current, the device allows load current greater than current limit threshold (typically 1.5A for RT9712A/B and 1A for RT9712C/D) at a short time as shown in Figure 1.

When the load current reaches the trigger point (typically 3.5A for RT9712A/B and 2.8A for RT9712C/D) or short circuit is applied to the output, the device will enter constant current mode until the thermal shutdown occurs or the fault is removed.

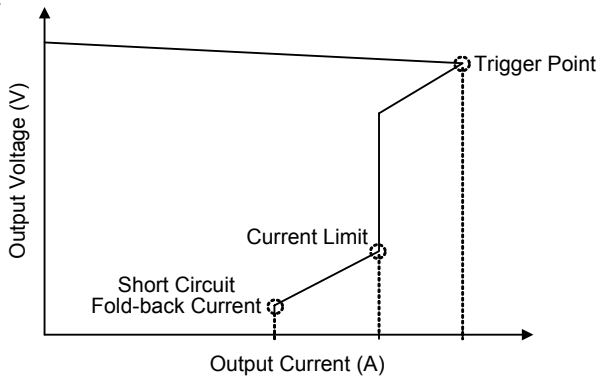

Figure 1. Current Limit

Universal Serial Bus (USB) & Power Distribution

The goal of USB is to enable device from different vendors to interoperate in an open architecture. USB features include ease of use for the end user, a wide range of workloads and applications, robustness, synergy with the PC industry, and low-cost implementation. Benefits include self-identifying peripherals, dynamically attachable and reconfigurable peripherals, multiple connections (support for concurrent operation of many devices), support for as many as 127 physical devices, and compatibility with PC Plug-and-Play architecture.

The Universal Serial Bus connects USB devices with a USB host: each USB system has one USB host. USB devices are classified either as hubs, which provide additional attachment points to the USB, or as functions, which provide capabilities to the system (for example, a digital joystick). Hub devices are then classified as either Bus-Power Hubs or Self-Powered Hubs.

A Bus-Powered Hub draws all of the power to any internal functions and downstream ports from the USB connector power pins. The hub may draw up to 500mA from the upstream device. External ports in a Bus-Powered Hub can supply up to 100mA per port, with a maximum of four external ports.

Self-Powered Hub power for the internal functions and downstream ports does not come from the USB, although the USB interface may draw up to 100mA from its upstream connect to allow the interface to function when the remainder of the hub is powered down. The hub must be able to supply up to 500mA on all of its external downstream ports. Please refer to Universal Serial Specification Revision 2.0 for more details on designing compliant USB hub and host systems.

Over-Current protection devices such as fuses and PTC resistors (also called polyfuse or polyswitch) have slow trip times, high on-resistance, and lack the necessary circuitry for USB-required fault reporting.

The faster trip time of the RT9712A/B/C/D power distribution allow designers to design hubs that can operate through faults. The RT9712A/B/C/D provide low on-resistance and internal fault-reporting circuitry to meet voltage regulation and fault notification requirements.

Because the devices are also power switches, the designer of self-powered hubs has the flexibility to turn off power to output ports. Unlike a normal MOSFET, the devices have controlled rise and fall times to provide the needed inrush current limiting required for the bus-powered hub power switch.

Supply Filter/Bypass Capacitor

A 0.1µF low-ESR ceramic capacitor from V_{IN} to GND, located at the device is strongly recommended to prevent the input voltage drooping during hot-plug events. However, higher capacitor values will further reduce the voltage droop on the input. Furthermore, without the bypass capacitor, an output short may cause sufficient ringing on the input (from source lead inductance) to destroy the internal control circuitry. The input transient must not exceed 6V of the absolute maximum supply voltage even for a short duration.

Output Filter Capacitor

A low-ESR 150µF aluminum electrolytic or tantalum between V_{OUT} and GND is strongly recommended to meet the 330mV maximum droop requirement in the hub V_{BUS} (Per USB 2.0, output ports must have a minimum 120µF of low-ESR bulk capacitance per hub). Standard bypass methods should be used to minimize inductance and resistance between the bypass capacitor and the downstream connector to reduce EMI and decouple voltage droop caused when downstream cables are hot-insertion transients. Ferrite beads in series with V_{BUS}, the ground line and the 0.1µF bypass capacitors at the power connector pins are recommended for EMI and ESD protection. The bypass capacitor itself should have a low dissipation factor to allow decoupling at higher frequencies.

Voltage Drop

The USB specification states a minimum port-output voltage in two locations on the bus, 4.75V out of a Self-Powered Hub port and 4.40V out of a Bus-Powered Hub port. As with the Self-Powered Hub, all resistive voltage drops for the Bus-Powered Hub must be accounted for to guarantee voltage regulation (see Figure 7-47 of Universal Serial Specification Revision 2.0).

The following calculation determines V_{OUT (MIN)} for multiple ports (N_{PORTS}) ganged together through one switch (if using one switch per port, N_{PORTS} is equal to 1) :

$$V_{OUT (MIN)} = 4.75V - [I_L \times (4 \times R_{CONN} + 2 \times R_{CABLE})] - (0.1A \times N_{PORTS} \times R_{SWITCH}) - V_{PCB}$$

Where

R_{CONN} = Resistance of connector contacts
(two contacts per connector)

R_{CABLE} = Resistance of upstream cable wires
(one 5V and one GND)

R_{SWITCH} = Resistance of power switch
(90mΩ typical for RT9712A/B/C/D)

V_{PCB} = PCB voltage drop

The USB specification defines the maximum resistance per contact (R_{CONN}) of the USB connector to be 30mΩ

and the drop across the PCB and switch to be 100mV. This basically leaves two variables in the equation: the resistance of the switch and the resistance of the cable. If the hub consumes the maximum current (I_L) of 500mA, the maximum resistance of the cable is 90mΩ.

The resistance of the switch can be defined as follows :

$$R_{SWITCH} = \{ 4.75V - 4.4V - [0.5A \times (4 \times 30m\Omega + 2 \times 90m\Omega)] - V_{PCB} \} \div (0.1A \times N_{PORTS})$$

$$= (200mV - V_{PCB}) \div (0.1A \times N_{PORTS})$$

If the voltage drop across the PCB is limited to 100mV, the maximum resistance for the switch is 250mΩ for four ports ganged together. The RT9712A/B/C/D, with its maximum 100mΩ on-resistance over temperature can fit the demand of this requirement.

Thermal Shutdown

Thermal protection limits power dissipation in the RT9712A/B/C/D. When the operation junction temperature exceeds 120°C (typ.), the OTP circuit starts the thermal shutdown function and turns the pass element off. The pass element turns on again after the junction temperature cools to 80°C. The IC lowers its OTP trip level from 120°C to 100°C when output short circuit occurs (V_{OUT} < 1V) as shown in Figure 2.

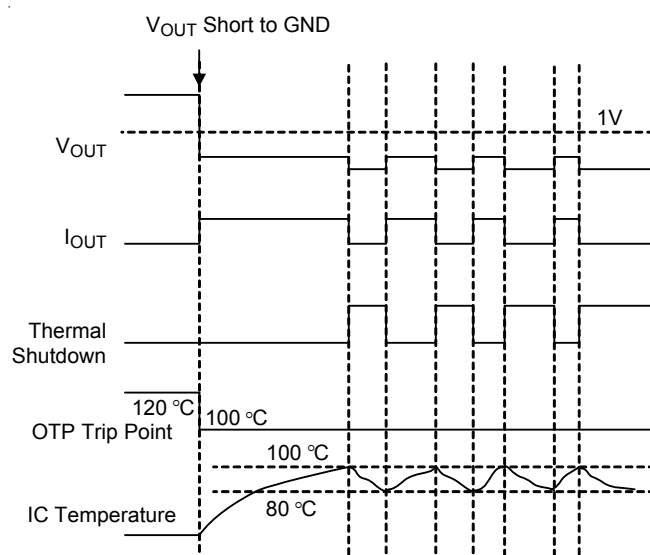

Figure 2. Short Circuit Thermal Folded Back Protection when Output Short Circuit Occurs (Patent)

Power Dissipation

The junction temperature of the RT9712 series depend on several factors such as the load, PCB layout, ambient temperature and package type. The output pin of RT9712A/B/C/D can deliver the current of up to 1.5A (RT9712A/B), and 0.6A (RT9712C/D) respectively over the full operating junction temperature range. However, the maximum output current must be derated at higher ambient temperature to ensure the junction temperature does not exceed 100°C. With all possible conditions, the junction temperature must be within the range specified under operating conditions. Power dissipation can be calculated based on the output current and the $R_{DS(ON)}$ of switch as below.

$$P_D = R_{DS(ON)} \times I_{OUT}^2$$

Although the devices are rated for 1.5A and 0.6A of output current, but the application may limit the amount of output current based on the total power dissipation and the ambient temperature.

For continuous operation, do not exceed absolute maximum operation junction temperature. The maximum power dissipation depends on the thermal resistance of IC package, PCB layout, the rate of surroundings airflow and temperature difference between junction to ambient. The maximum power dissipation can be calculated by following formula :

$$P_{D(MAX)} = (T_{J(MAX)} - T_A) / \theta_{JA}$$

Where $T_{J(MAX)}$ is the maximum operation junction temperature 100°C, T_A is the ambient temperature and the θ_{JA} is the junction to ambient thermal resistance.

For recommended operating conditions specification, where $T_{J(MAX)}$ is the maximum junction temperature of the die (100°C) and T_A is the maximum ambient temperature. The junction to ambient thermal resistance θ_{JA} is layout dependent. For SOP-8 and MSOP-8 packages, the thermal resistance θ_{JA} is 160°C/W. The maximum power dissipation at $T_A = 25^\circ\text{C}$ can be calculated by following formula :

$$P_{D(MAX)} = (100^\circ\text{C} - 25^\circ\text{C}) / (160^\circ\text{C/W}) = 0.469\text{W for SOP-8 and MSOP-8 packages}$$

The maximum power dissipation depends on the operating ambient temperature for fixed $T_{J(MAX)}$ and thermal resistance, θ_{JA} . The derating curve in Figure 3 allows the designer to see the effect of rising ambient temperature on the maximum power dissipation.

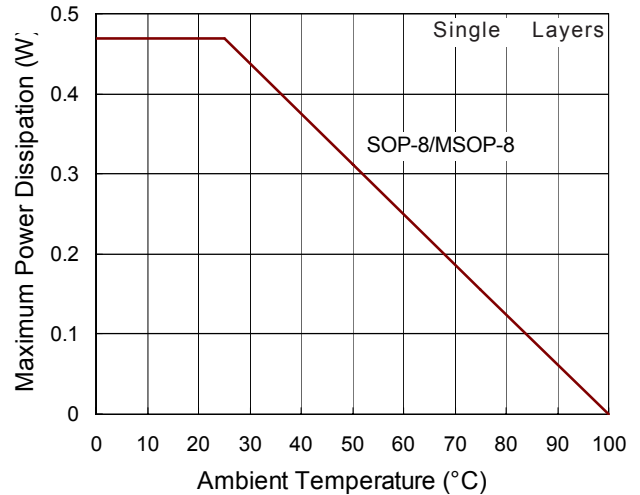

Figure 3. Derating Curve of Maximum Power Dissipation

Layout Consideration

For best performance of the RT9712 series, the following guidelines must be strictly followed.

- ▶ Input and output capacitors should be placed close to the IC and connected to ground plane to reduce noise coupling.
- ▶ The GND should be connected to a strong ground plane for heat sink.
- ▶ Keep the main current traces as possible as short and wide.

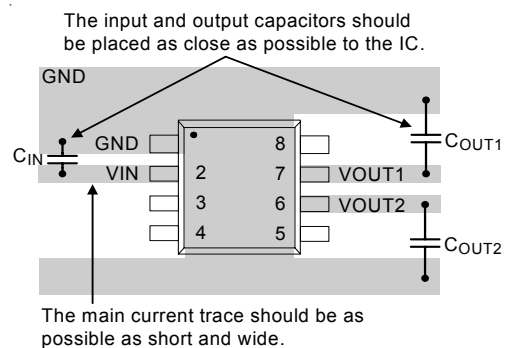
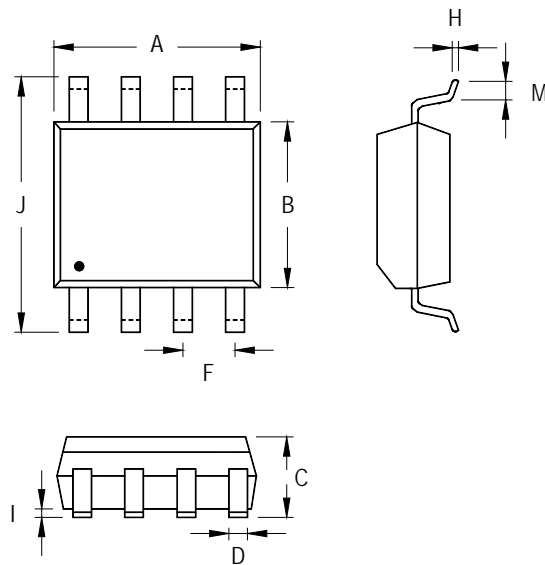

Figure 4. PCB Layout Guide

Outline Dimension



Symbol	Dimensions In Millimeters		Dimensions In Inches	
	Min	Max	Min	Max
A	4.801	5.004	0.189	0.197
B	3.810	3.988	0.150	0.157
C	1.346	1.753	0.053	0.069
D	0.330	0.508	0.013	0.020
F	1.194	1.346	0.047	0.053
H	0.170	0.254	0.007	0.010
I	0.050	0.254	0.002	0.010
J	5.791	6.200	0.228	0.244
M	0.400	1.270	0.016	0.050

8-Lead SOP Plastic Package

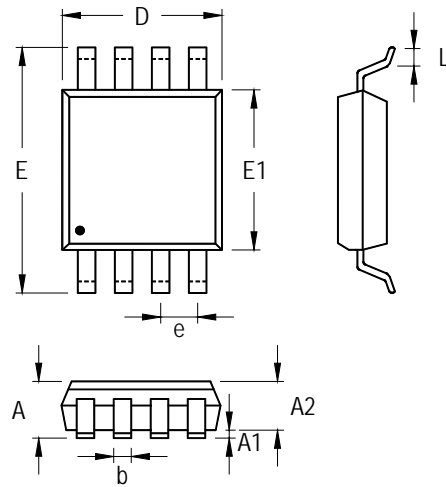

Symbol	Dimensions In Millimeters		Dimensions In Inches	
	Min	Max	Min	Max
A	0.810	1.100	0.032	0.043
A1	0.000	0.150	0.000	0.006
A2	0.750	0.950	0.030	0.037
b	0.220	0.380	0.009	0.015
D	2.900	3.100	0.114	0.122
e	0.650		0.026	
E	4.800	5.000	0.189	0.197
E1	2.900	3.100	0.114	0.122
L	0.400	0.800	0.016	0.031

8-Lead MSOP Plastic Package



Richtek Technology Corporation

5F, No. 20, Taiyuen Street, Chupei City
 Hsinchu, Taiwan, R.O.C.
 Tel: (8863)5526789

Richtek products are sold by description only. Richtek reserves the right to change the circuitry and/or specifications without notice at any time. Customers should obtain the latest relevant information and data sheets before placing orders and should verify that such information is current and complete. Richtek cannot assume responsibility for use of any circuitry other than circuitry entirely embodied in a Richtek product. Information furnished by Richtek is believed to be accurate and reliable. However, no responsibility is assumed by Richtek or its subsidiaries for its use; nor for any infringements of patents or other rights of third parties which may result from its use. No license is granted by implication or otherwise under any patent or patent rights of Richtek or its subsidiaries.

Looking for pricing, stock, or lifecycle information?

Click below to explore more details on WIN SOURCE:

-  [View RT9712AGF on WIN SOURCE](#)
-  [Richtek USA Inc. Information](#)

Optimize Your Supply Chain with WIN SOURCE Solutions

-  Global Sourcing Solution
-  Obsolete Management
-  Cost Control Management
-  Shortage Management
-  Alternative Solution
-  Excess Inventory Management