



THE DATASHEET OF IRGS4045DPBF



INSULATED GATE BIPOLAR TRANSISTOR WITH
ULTRAFAST SOFT RECOVERY DIODE

$$V_{CES} = 600V$$

$$I_C = 6.0A, T_C = 100^\circ C$$

$$t_{sc} > 5\mu s, T_{jmax} = 175^\circ C$$

$$V_{CE(on) typ.} = 1.7V$$

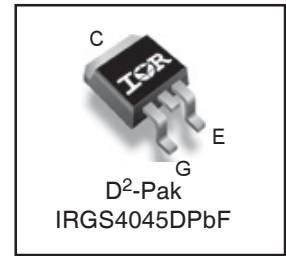
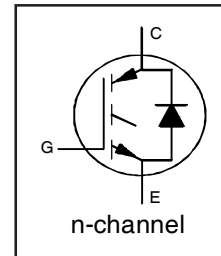

G	C	E
Gate	Collector	Emitter

Applications

- Appliance Motor Drive
- Inverters
- SMPS

Features	Benefits
Low $V_{CE(ON)}$ and switching losses	High efficiency in a wide range of applications and switching frequencies
Square RBSOA and maximum junction temperature 175°C	Improved reliability due to rugged hard switching performance and higher power capability
Positive $V_{CE(ON)}$ temperature coefficient and tighter distribution of parameters	Excellent current sharing in parallel operation
5 μ s short circuit SOA	Enables short circuit protection scheme
Ultra fast soft recovery copak diode	Performance optimized for motor drive operation
Lead-free, RoHS compliant	Environmentally friendly

Base part number	Package Type	Standard Pack		Orderable Part Number
		Form	Quantity	
IRGS4045DPbF	D2Pak	Tube	50	IRGS4045DPbF
		Tape and Reel Left	800	IRGS4045DTRLpBF
		Tape and Reel Right	800	IRGS4045DTRRpBF

Absolute Maximum Ratings

	Parameter	Max.	Units
V_{CES}	Collector-to-Emitter Breakdown Voltage	600	V
$I_C @ T_C = 25^\circ C$	Continuous Collector Current	12	A
$I_C @ T_C = 100^\circ C$	Continuous Collector Current	6.0	
I_{CM}	Pulsed Collector Current, $V_{GE} = 15V$	18	
I_{LM}	Clamped Inductive Load Current, $V_{GE} = 20V$ ①	24	
$I_F @ T_C = 25^\circ C$	Diode Continuous Forward Current	8.0	
$I_F @ T_C = 100^\circ C$	Diode Continuous Forward Current	4.0	
I_{FM}	Diode Maximum Forward Current ②	24	V
V_{GE}	Continuous Gate-to-Emitter Voltage	± 20	
	Transient Gate-to-Emitter Voltage	± 30	
$P_D @ T_C = 25^\circ$	Maximum Power Dissipation	77	W
$P_D @ T_C = 100^\circ$	Maximum Power Dissipation	39	
T_J	Operating Junction and	-55 to + 175	°C
T_{STG}	Storage Temperature Range		
	Soldering Temperature, for 10 seconds	300 (0.063 in. (1.6mm) from case)	

Thermal Resistance

	Parameter	Min.	Typ.	Max.	Units
$R_{\theta JC}$	Junction-to-Case - IGBT ③	—	—	1.9	°C/W
$R_{\theta JC}$	Junction-to-Case - Diode ③	—	—	6.3	
$R_{\theta CS}$	Case-to-Sink, Flat, Greased Surface	—	0.5	—	
$R_{\theta JA}$	Junction-to-Ambient (PCB Mountet, steady-state) ⑤	—	—	40	

*Qualification standards can be found at <http://www.irf.com/>

Electrical Characteristics @ T_J = 25°C (unless otherwise specified)

	Parameter	Min.	Typ.	Max.	Units	Conditions
V _{(BR)CES}	Collector-to-Emitter Breakdown Voltage	600	—	—	V	V _{GE} = 0V, I _C = 100 μA ④
ΔV _{(BR)CES} /ΔT _J	Temperature Coeff. of Breakdown Voltage	—	0.36	—	V/°C	V _{GE} = 0V, I _C = 250 μA (25 -175 °C) ④
V _{CE(on)}	Collector-to-Emitter Saturation Voltage	—	1.7	2.0	V	I _C = 6.0A, V _{GE} = 15V, T _J = 25°C
		—	2.07	—		I _C = 6.0A, V _{GE} = 15V, T _J = 150°C
		—	2.14	—		I _C = 6.0A, V _{GE} = 15V, T _J = 175°C
V _{GE(th)}	Gate Threshold Voltage	4.0	—	6.5	V	V _{CE} = V _{GE} , I _C = 150 μA
ΔV _{GE(th)} /ΔT _J	Threshold Voltage temp. coefficient	—	-13	—	mV/°C	V _{CE} = V _{GE} , I _C = 250 μA (25 -175 °C)
g _{fe}	Forward Transconductance	—	5.8	—	S	V _{CE} = 25V, I _C = 6.0A, PW = 80 μs
I _{CES}	Collector-to-Emitter Leakage Current	—	—	25	μA	V _{GE} = 0V, V _{CE} = 600V
		—	—	250		V _{GE} = 0V, V _{CE} = 600V, T _J = 175°C
V _{FM}	Diode Forward Voltage Drop	—	1.60	2.30	V	I _F = 6.0A
		—	1.30	—		I _F = 6.0A, T _J = 175°C
I _{GES}	Gate-to-Emitter Leakage Current	—	—	±100	nA	V _{GE} = ± 20 V

Switching Characteristics @ T_J = 25°C (unless otherwise specified)

	Parameter	Min.	Typ.	Max. ⑥	Units	Conditions
Q _g	Total Gate Charge (turn-on)	—	13	19.5	nC	I _C = 6.0A
Q _{ge}	Gate-to-Emitter Charge (turn-on)	—	3.1	4.65		V _{CC} = 400V
Q _{gc}	Gate-to-Collector Charge (turn-on)	—	6.4	9.6		V _{GE} = 15V
E _{on}	Turn-On Switching Loss	—	56	86	μJ	I _C = 6.0A, V _{CC} = 400V, V _{GE} = 15V
E _{off}	Turn-Off Switching Loss	—	122	143		R _G = 47Ω, L = 1mH, L _S = 150nH, T _J = 25°C
E _{total}	Total Switching Loss	—	178	229		Energy losses include tail and diode reverse recovery
t _{d(on)}	Turn-On delay time	—	27	35	ns	I _C = 6.0A, V _{CC} = 400V
t _r	Rise time	—	11	15		R _G = 47Ω, L = 1mH, L _S = 150nH
t _{d(off)}	Turn-Off delay time	—	75	93		T _J = 25°C
t _f	Fall time	—	17	22		
E _{on}	Turn-On Switching Loss	—	140	—	μJ	I _C = 6.0A, V _{CC} = 400V, V _{GE} = 15V
E _{off}	Turn-Off Switching Loss	—	189	—		R _G = 47Ω, L = 1mH, L _S = 150nH, T _J = 175°C
E _{total}	Total Switching Loss	—	329	—		Energy losses include tail and diode reverse recovery
t _{d(on)}	Turn-On delay time	—	26	—	ns	I _C = 6.0A, V _{CC} = 400V
t _r	Rise time	—	12	—		R _G = 47Ω, L = 1mH, L _S = 150nH
t _{d(off)}	Turn-Off delay time	—	95	—		T _J = 175°C
t _f	Fall time	—	32	—		
C _{ies}	Input Capacitance	—	350	—	pF	V _{GE} = 0V
C _{oes}	Output Capacitance	—	29	—		V _{CC} = 30V
C _{res}	Reverse Transfer Capacitance	—	10	—		f = 1Mhz
RBSOA	Reverse Bias Safe Operating Area	FULL SQUARE				T _J = 175°C, I _C = 24A V _{CC} = 500V, V _p = 600V R _G = 100Ω, V _{GE} = +20V to 0V
SCSOA	Short Circuit Safe Operating Area	5	—	—	μs	V _{CC} = 400V, V _p = 600V R _G = 100Ω, V _{GE} = +15V to 0V
E _{rec}	Reverse recovery energy of the diode	—	178	—	μJ	T _J = 175°C
t _{rr}	Diode Reverse recovery time	—	74	—	ns	V _{CC} = 400V, I _F = 6.0A
I _{rr}	Peak Reverse Recovery Current	—	12	—	A	V _{GE} = 15V, R _G = 47Ω, L = 1mH, L _S = 150nH

Notes:

- ① V_{CC} = 80% (V_{CES}), V_{GE} = 15V, L = 1.0mH, R_G = 47Ω.
- ② Pulse width limited by max. junction temperature.
- ③ R_θ is measured at T_J approximately 90°C.
- ④ Refer to AN-1086 for guidelines for measuring V_{(BR)CES} safely.
- ⑤ When mounted on 1" square PCB (FR-4 or G-10 Material). For recommended footprint and soldering techniques refer to application note #AN-994.
- ⑥ Maximum limits are based on statistical sample size characterization.

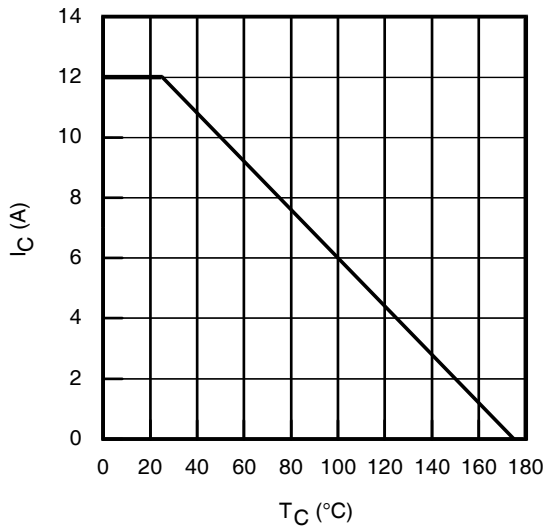

Fig. 1 - Maximum DC Collector Current vs. Case Temperature

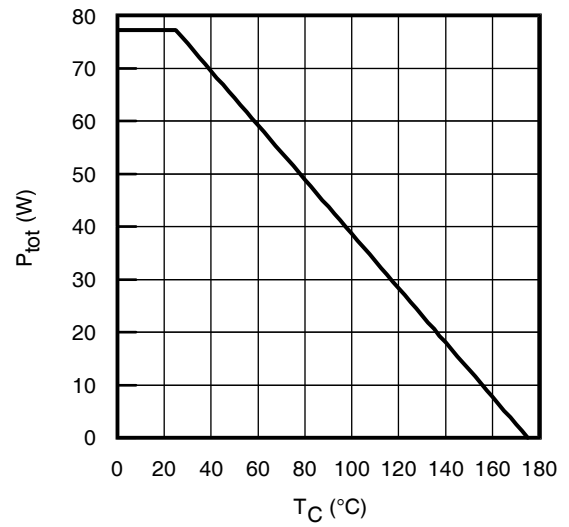

Fig. 2 - Power Dissipation vs. Case Temperature

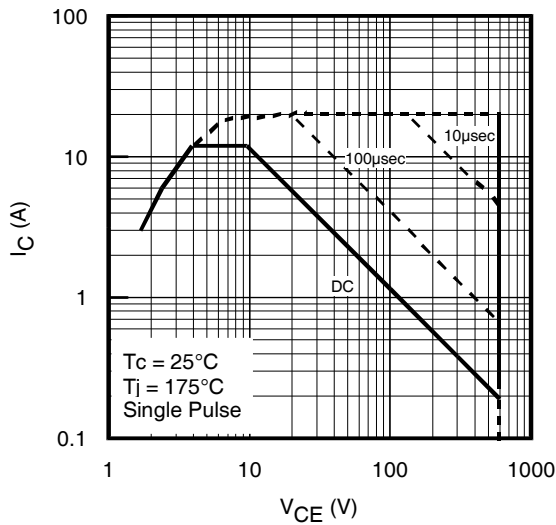

Fig. 3 - Forward SOA,
 $T_C = 25^\circ\text{C}$, $T_J \leq 175^\circ\text{C}$, $V_{GE} = 15\text{V}$

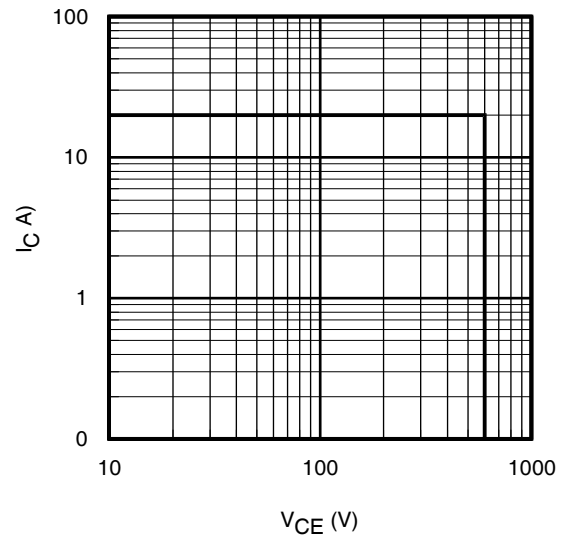

Fig. 4 - Reverse Bias SOA
 $T_J = 175^\circ\text{C}$, $V_{GE} = 20\text{V}$

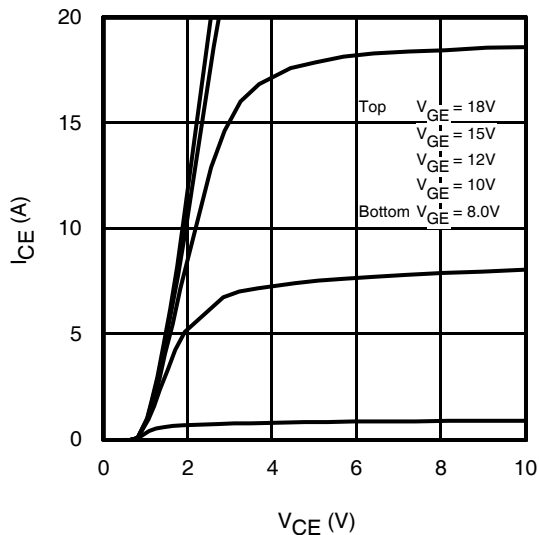

Fig. 5 - Typ. IGBT Output Characteristics
 $T_J = -40^\circ\text{C}$; $t_p = 80\mu\text{s}$

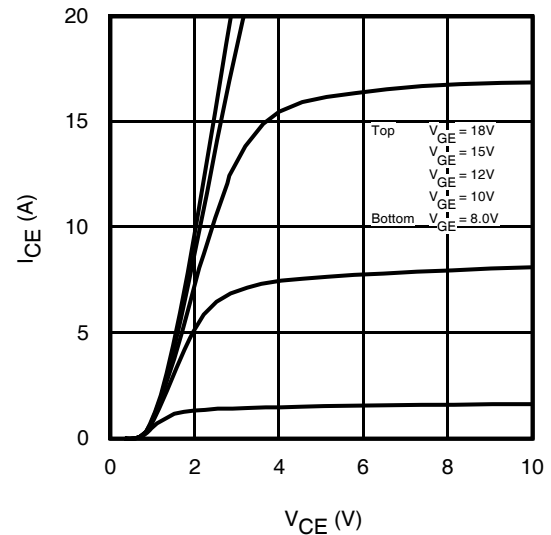

Fig. 6 - Typ. IGBT Output Characteristics
 $T_J = 25^\circ\text{C}$; $t_p = 80\mu\text{s}$

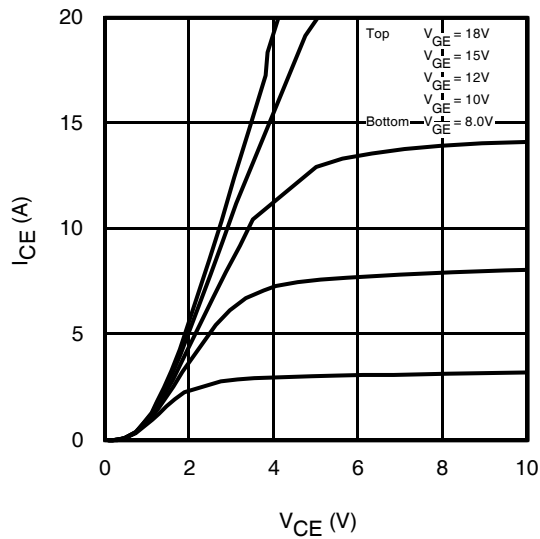

Fig. 7 - Typ. IGBT Output Characteristics
 $T_J = 175^\circ C$; $t_p = 80\mu s$

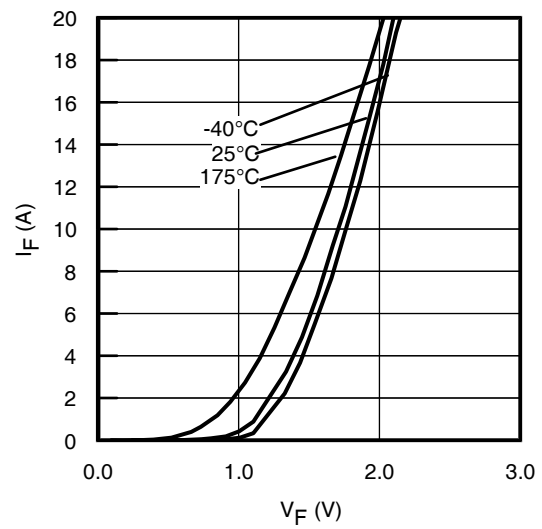

Fig. 8 - Typ. Diode Forward Characteristics
 $t_p = 80\mu s$

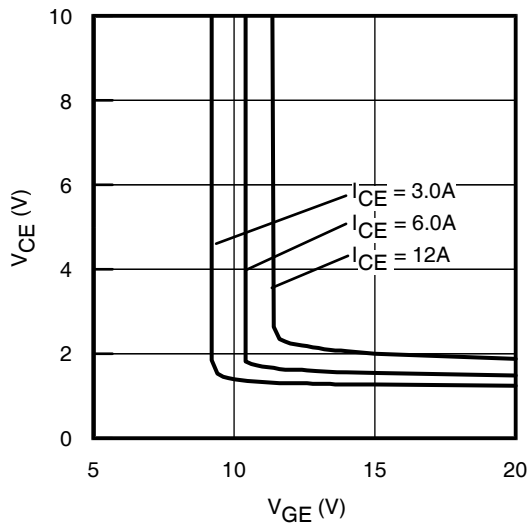

Fig. 9 - Typical V_{CE} vs. V_{GE}
 $T_J = -40^\circ C$

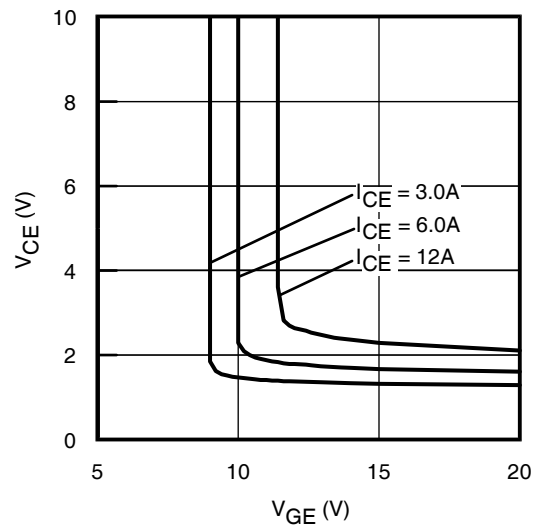

Fig. 10 - Typical V_{CE} vs. V_{GE}
 $T_J = 25^\circ C$

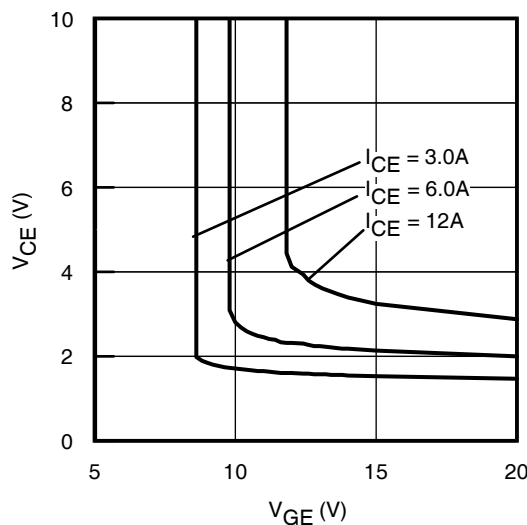

Fig. 11 - Typical V_{CE} vs. V_{GE}
 $T_J = 175^\circ C$

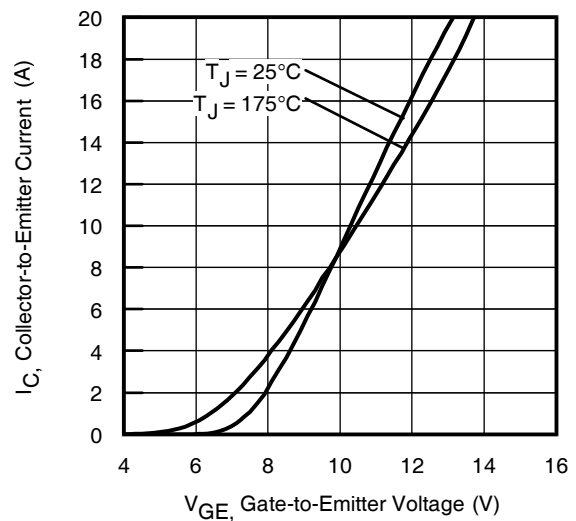

Fig. 12 - Typ. Transfer Characteristics
 $V_{CE} = 50V$; $t_p = 10\mu s$

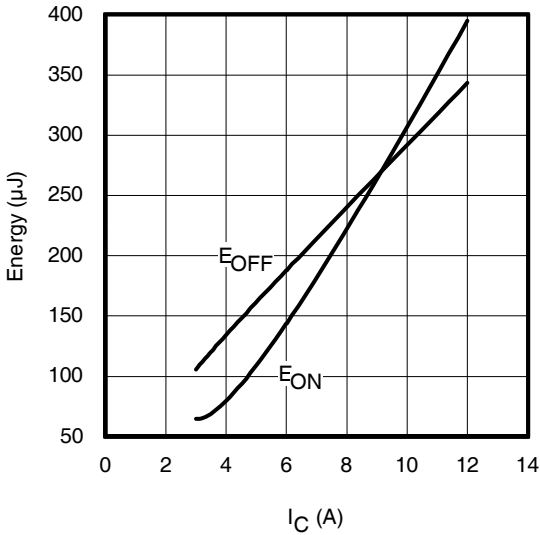

Fig. 13 - Typ. Energy Loss vs. I_C
 $T_J = 175^\circ\text{C}$; $L = 1\text{mH}$; $V_{CE} = 400\text{V}$, $R_G = 47\Omega$; $V_{GE} = 15\text{V}$.

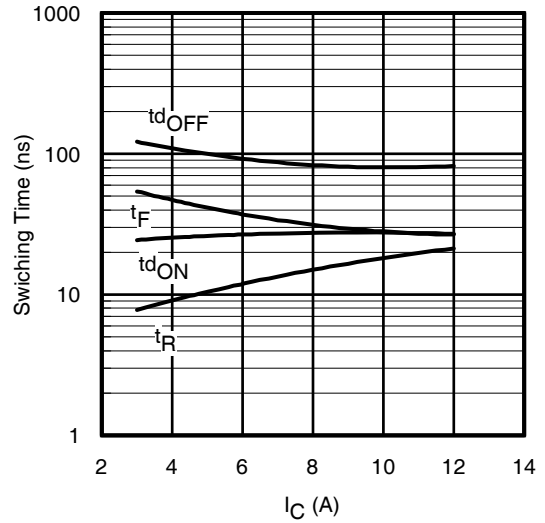

Fig. 14 - Typ. Switching Time vs. I_C
 $T_J = 175^\circ\text{C}$; $L = 1\text{mH}$; $V_{CE} = 400\text{V}$
 $R_G = 47\Omega$; $V_{GE} = 15\text{V}$

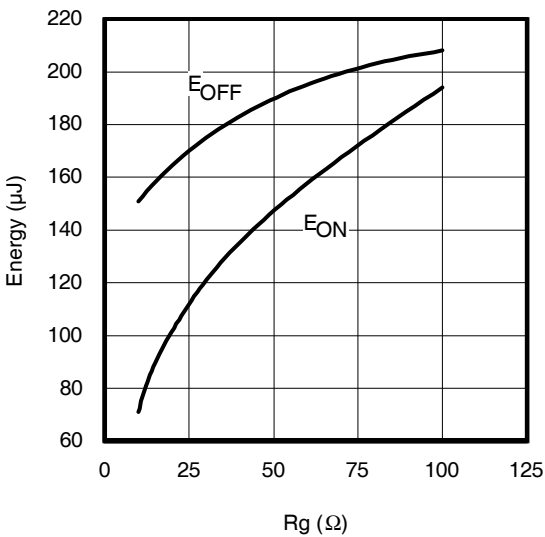

Fig. 15 - Typ. Energy Loss vs. R_G
 $T_J = 175^\circ\text{C}$; $L = 1\text{mH}$; $V_{CE} = 400\text{V}$, $I_{CE} = 6.0\text{A}$; $V_{GE} = 15\text{V}$

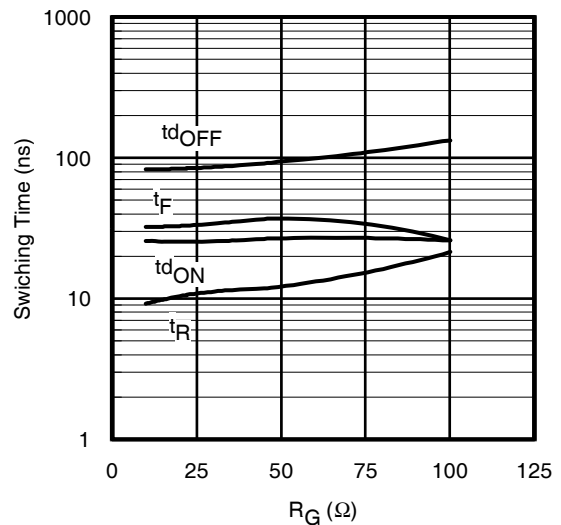

Fig. 16 - Typ. Switching Time vs. R_G
 $T_J = 175^\circ\text{C}$; $L = 1\text{mH}$; $V_{CE} = 400\text{V}$
 $I_{CE} = 6.0\text{A}$; $V_{GE} = 15\text{V}$

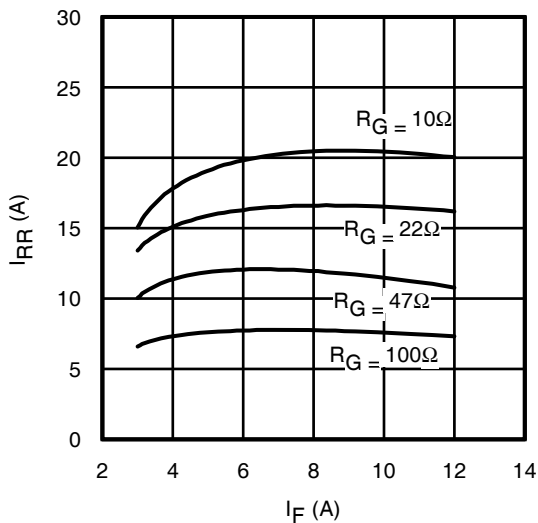

Fig. 17 - Typical Diode I_{RR} vs. I_F
 $T_J = 175^\circ\text{C}$

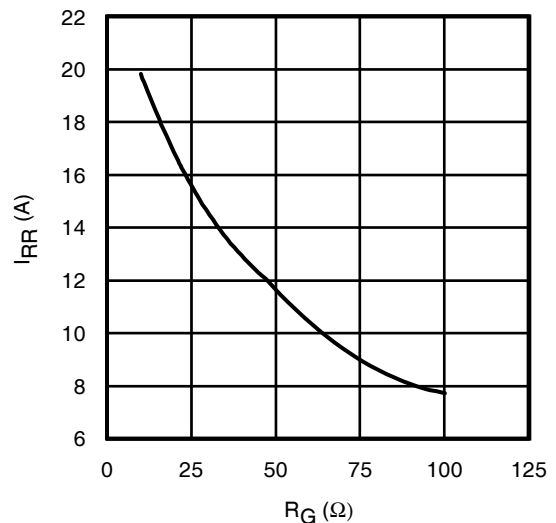

Fig. 18 - Typical Diode I_{RR} vs. R_G
 $T_J = 175^\circ\text{C}$; $I_F = 6.0\text{A}$

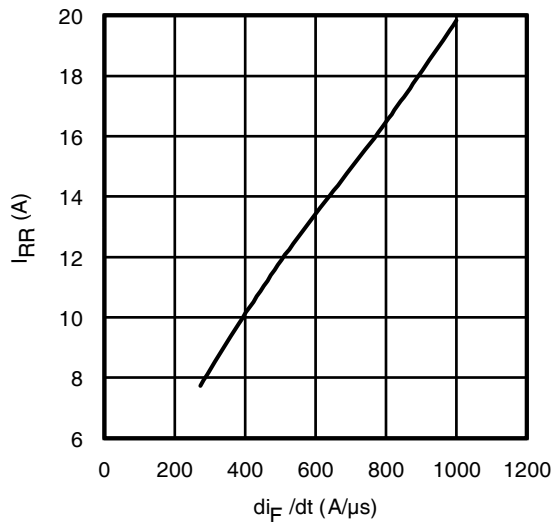

Fig. 19- Typical Diode I_{RR} vs. di_F/dt
 $V_{CC}= 400V$; $V_{GE}= 15V$;
 $I_{CE}= 6.0A$; $T_J = 175^{\circ}C$

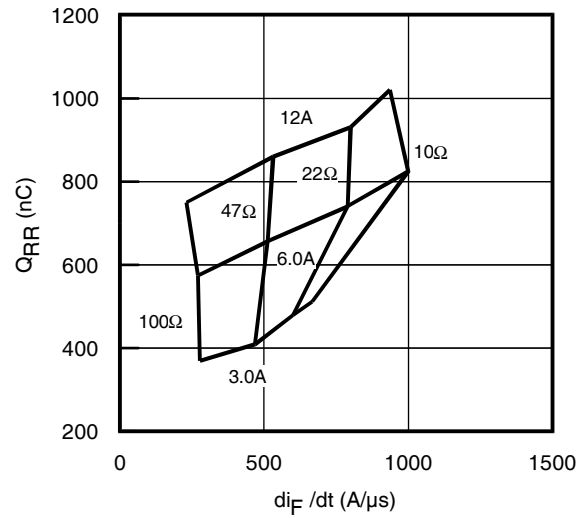

Fig. 20 - Typical Diode Q_{RR}
 $V_{CC}= 400V$; $V_{GE}= 15V$; $T_J = 175^{\circ}C$

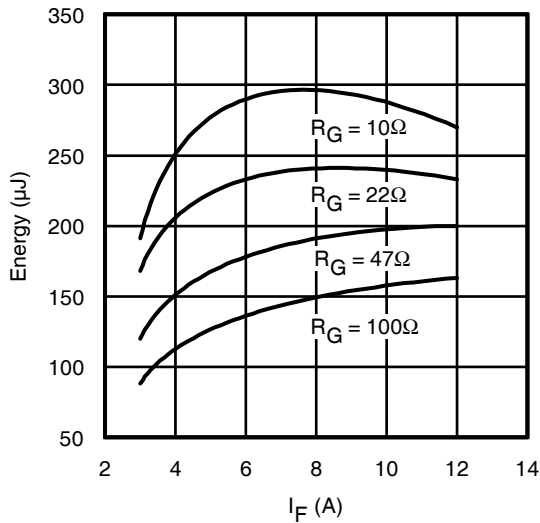

Fig. 21 - Typical Diode E_{RR} vs. I_F
 $T_J = 175^{\circ}C$

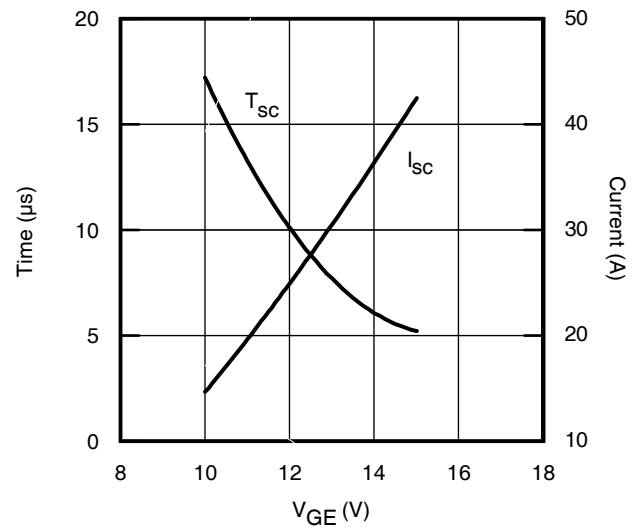

Fig. 22- Typ. V_{GE} vs. Short Circuit Time
 $V_{CC}=400V$, $T_C = 25^{\circ}C$

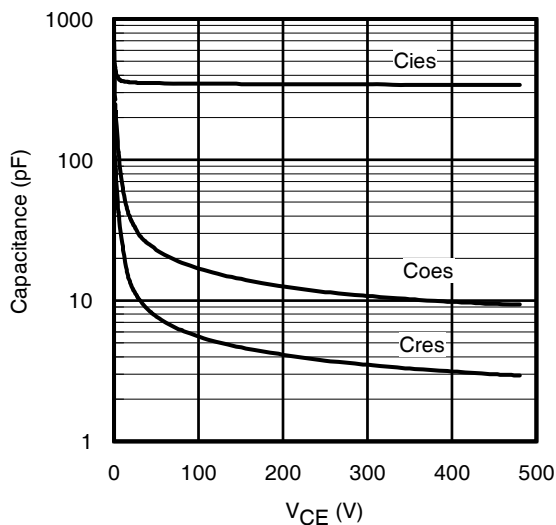

Fig. 23- Typ. Capacitance vs. V_{CE}
 $V_{GE}= 0V$; $f = 1MHz$

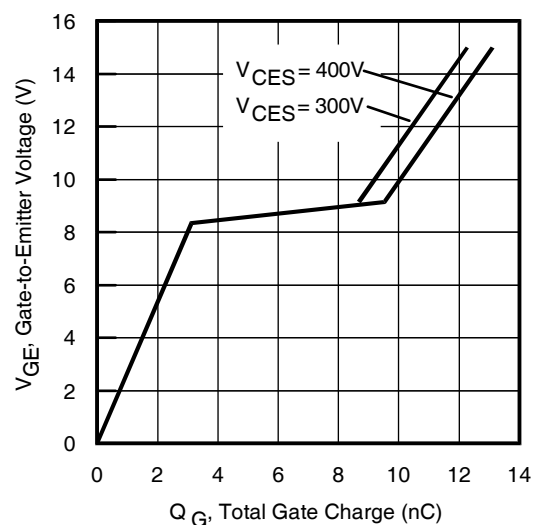
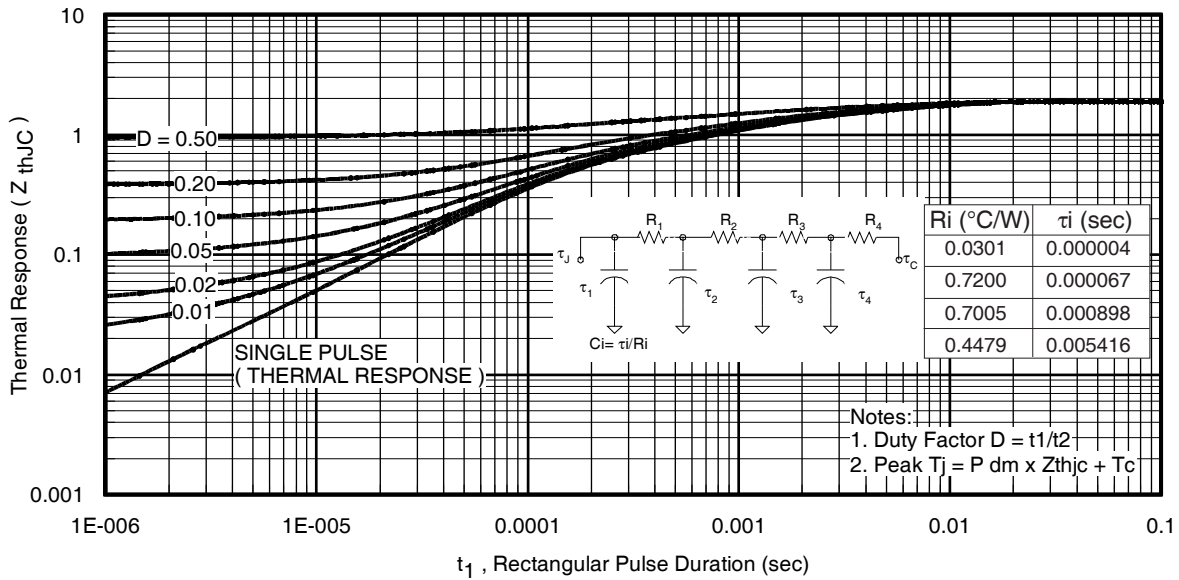
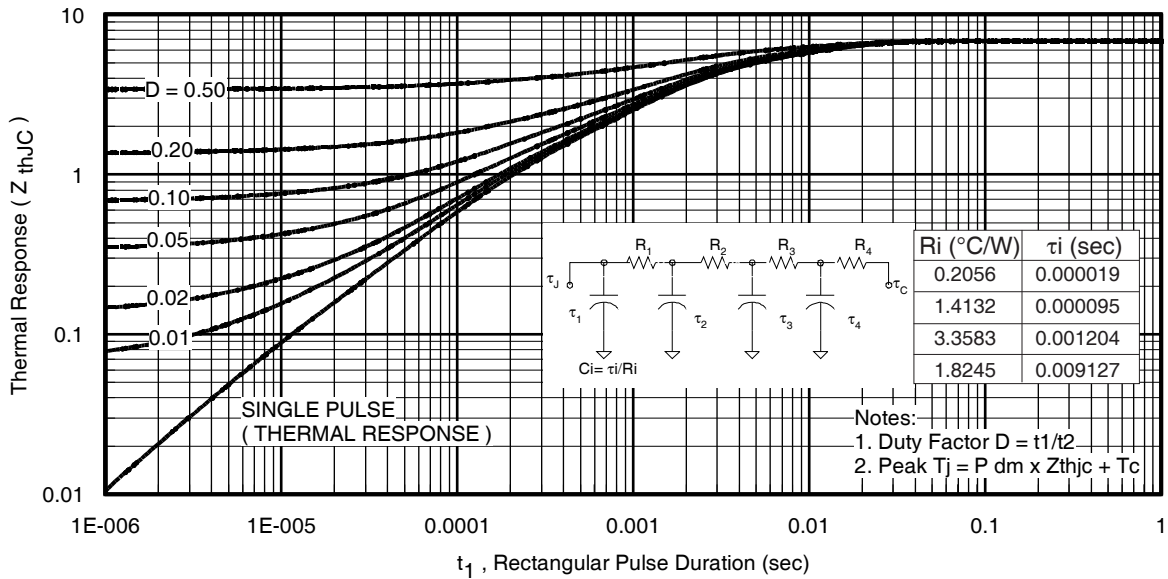
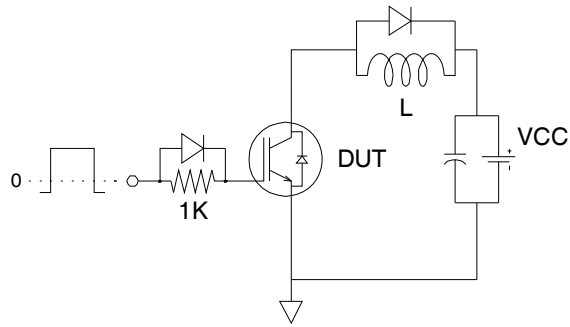
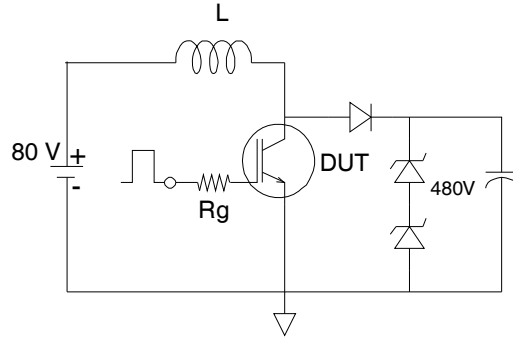
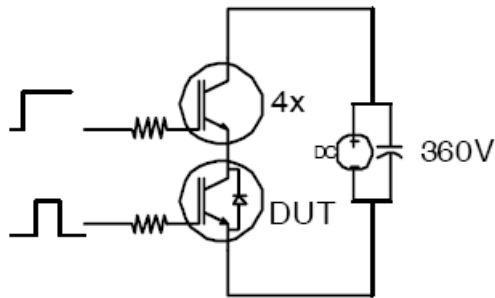
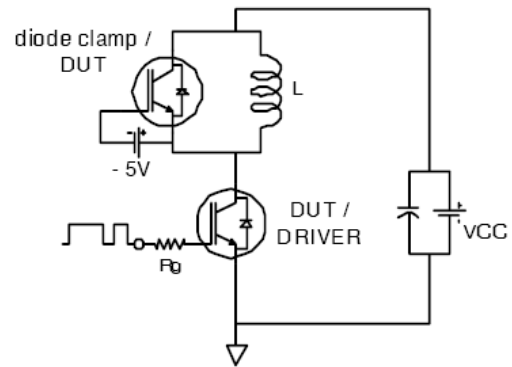
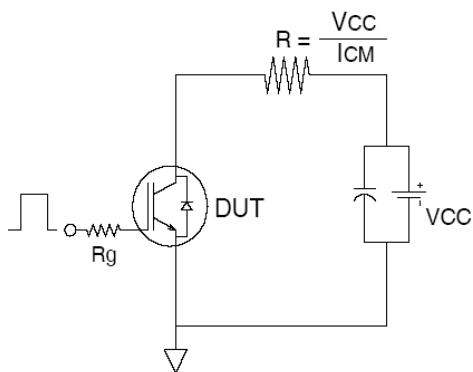
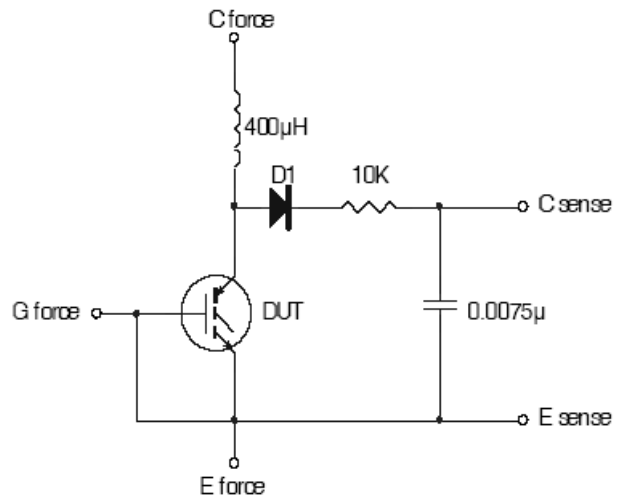

Fig. 24 - Typical Gate Charge vs. V_{GE}
 $I_{CE} = 6.0A$, $L=600\mu H$

Fig 25. Maximum Transient Thermal Impedance, Junction-to-Case (IGBT)

Fig 26. Maximum Transient Thermal Impedance, Junction-to-Case (DIODE)

Fig.C.T.1 - Gate Charge Circuit (turn-off)

Fig.C.T.2 - RBSOA Circuit

Fig.C.T.3 - S.C.SOA Circuit

Fig.C.T.4 - Switching Loss Circuit

Fig.C.T.5 - Resistive Load Circuit

Fig.C.T.6 - Typical Filter Circuit for $V_{(BR)CES}$ Measurement

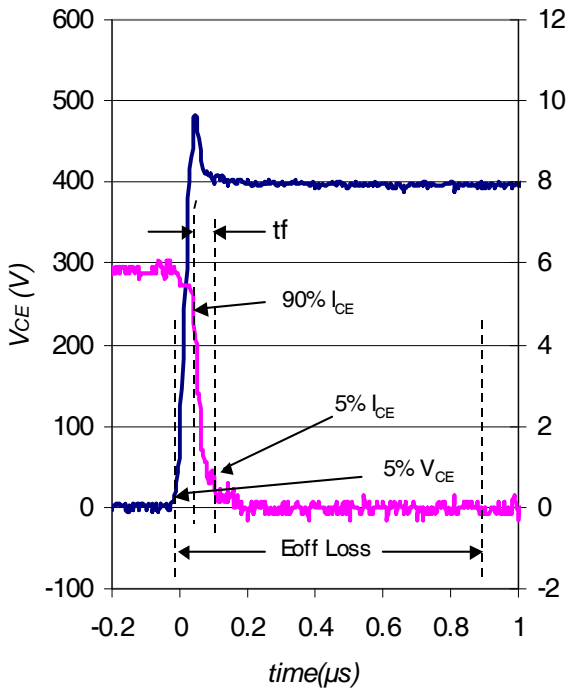

Fig. WF1 - Typ. Turn-off Loss Waveform
@ $T_J = 175^\circ\text{C}$ using Fig. CT.4

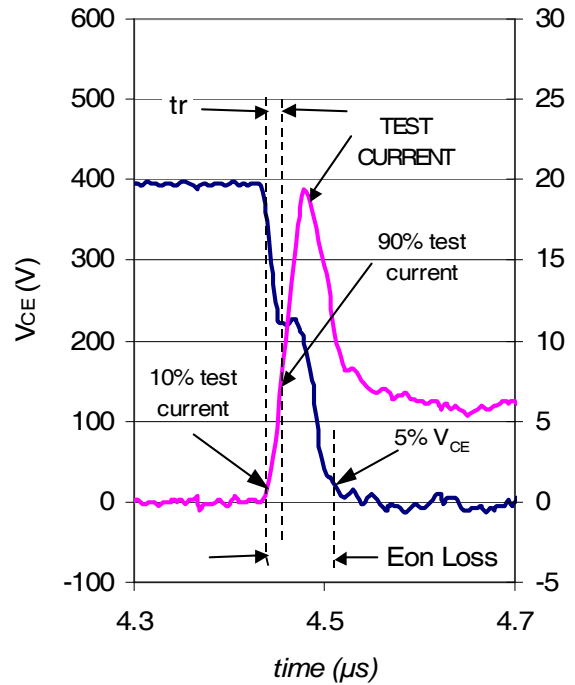
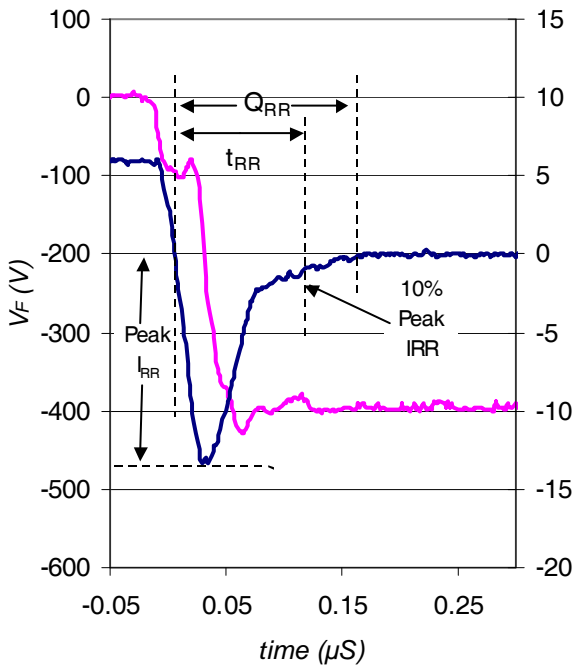
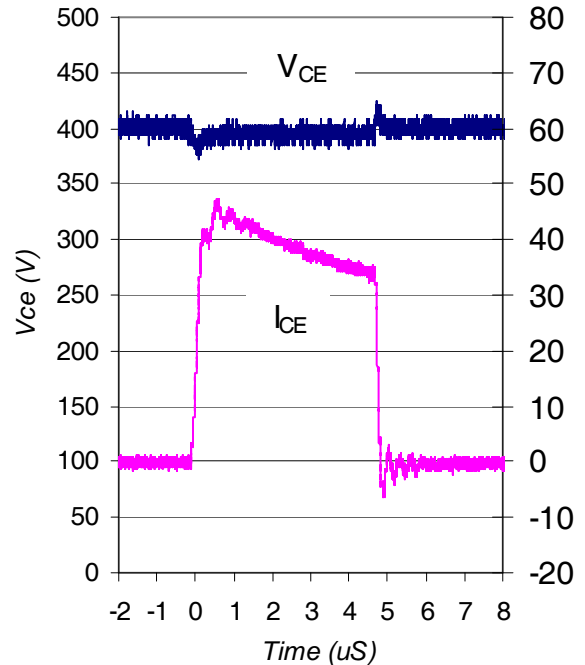

Fig. WF2 - Typ. Turn-on Loss Waveform
@ $T_J = 175^\circ\text{C}$ using Fig. CT.4



WF.3- Typ. Diode Recovery Waveform
@ $T_J = 175^\circ\text{C}$ using CT.4



WF.4- Typ. Short Circuit Waveform
@ $T_J = 25^\circ\text{C}$ using CT.3

D²Pak Package Outline

Dimensions are shown in millimeters (inches)

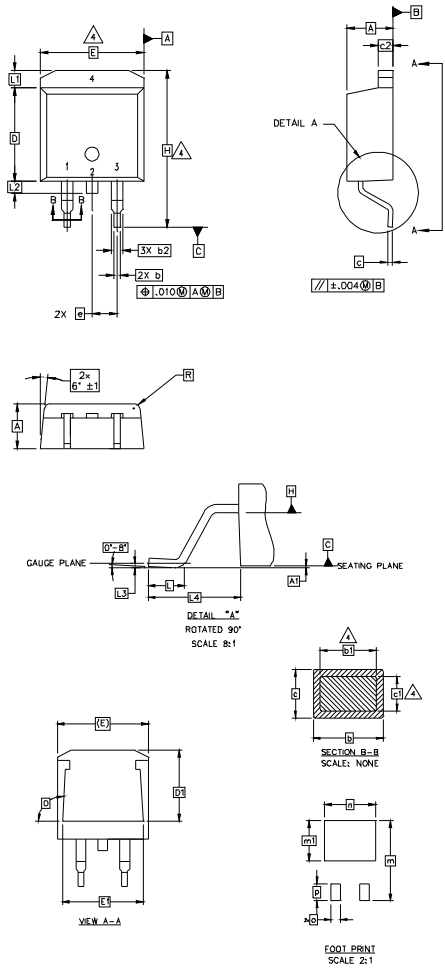

NOTES:

1. DIMENSIONING AND TOLERANCING PER ASME Y14.5M-1994
2. DIMENSIONS ARE SHOWN IN MILLIMETERS [INCHES].
3. DIMENSION D & E DO NOT INCLUDE MOLD FLASH. MOLD FLASH SHALL NOT EXCEED 0.127 [.005"] PER SIDE. THESE DIMENSIONS ARE MEASURED AT THE OUTMOST EXTREMES OF THE PLASTIC BODY.
4. DIMENSION b1 AND c1 APPLY TO BASE METAL ONLY.
5. CONTROLLING DIMENSION: INCH.

SYMBOL	DIMENSIONS				NOTES
	MILLIMETERS		INCHES		
	MIN.	MAX.	MIN.	MAX.	
A	4.06	4.83	.160	.190	4
A1	0.00	0.254	.000	.010	
b	0.51	0.99	.020	.039	
b1	0.51	0.89	.020	.035	
b2	1.14	1.78	.045	.070	
c	0.38	0.74	.015	.029	
c1	0.38	0.58	.015	.023	
c2	1.14	1.65	.045	.065	
D	8.51	9.65	.335	.380	
D1	6.86		.270		
E	9.65	10.67	.380	.420	3
E1	6.22		.245		
e	2.54 BSC		.100 BSC		3
H	14.61	15.88	.575	.625	
L	1.78	2.79	.070	.110	
L1		1.65		.065	
L2	1.27	1.78	.050	.070	
L3	0.25 BSC		.010 BSC		
L4	4.78	5.28	.188	.208	
m	17.78		.700		
m1	8.89		.350		
n	11.43		.450		
o	2.08		.082		
p	3.81		.150		
R	0.51	0.71	.020	.028	4
θ	90°	93°	90°	93°	

LEAD ASSIGNMENTS

HEXFET

- 1.- GATE
- 2, 4.- DRAIN
- 3.- SOURCE

IGBTs, CoPACK

- 1.- GATE
- 2, 4.- COLLECTOR
- 3.- EMITTER

DIODES

- 1.- ANODE *
- 2, 4.- CATHODE
- 3.- ANODE

* PART DEPENDENT.

D²Pak Part Marking Information

EXAMPLE: THIS IS AN IRF530S WITH
LOT CODE 8024
ASSEMBLED ON WW 02, 2000
IN THE ASSEMBLY LINE "L"

Note: "P" in assembly line position
indicates "Lead - Free"

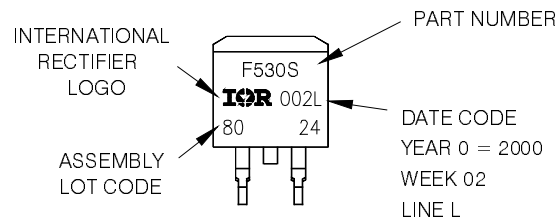

OR

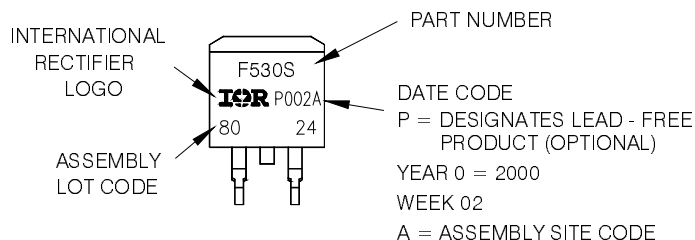

Note: For the most current drawing please refer to IR website at <http://www.irf.com/package/>

D²Pak Tape & Reel Information

Dimensions are shown in millimeters (inches)

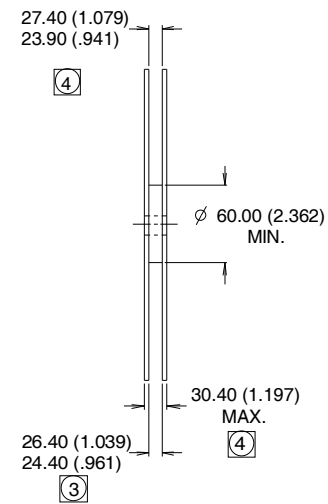
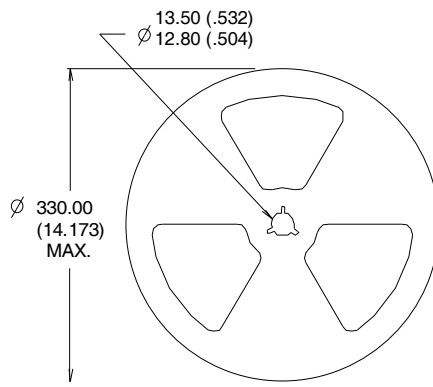
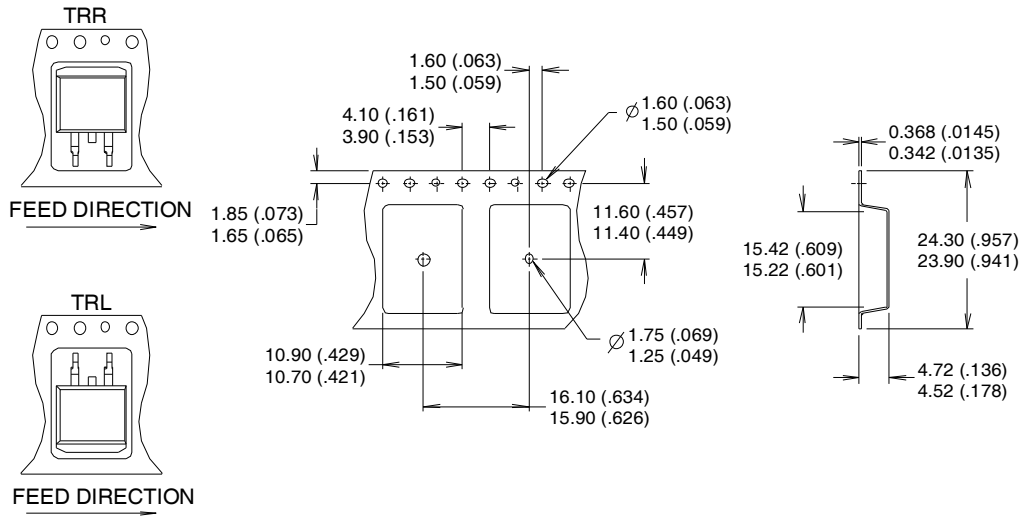

- NOTES :
1. COMFORMS TO EIA-418.
 2. CONTROLLING DIMENSION: MILLIMETER.
 - ③ DIMENSION MEASURED @ HUB.
 - ④ INCLUDES FLANGE DISTORTION @ OUTER EDGE.

Qualification Information[†]

Qualification Level		Industrial ^{††} (per JEDEC JESD47F) ^{†††}	
Moisture Sensitivity Level		D2Pak	MSL1 (per JEDEC J-STD-020D) ^{†††}
ESD	Machine Model	Class M2 (+/- 200V) ^{†††} AEC-Q101-002	
	Human Body Model	Class H1A (+/- 500V) ^{†††} AEC-Q101-001	
	Charged Device Model	Class C5 (+/- 1000V) ^{†††} AEC-Q101-005	
RoHS Compliant		Yes	

† Qualification standards can be found at International Rectifier's web site: <http://www.irf.com/product-info/reliability/>

†† Higher qualification ratings may be available should the user have such requirements. Please contact your International Rectifier sales representative for further information: <http://www.irf.com/whoto-call/salesrep/>

††† Applicable version of JEDEC standard at the time of product release.

Data and specifications subject to change without notice.

International
 Rectifier

IR WORLD HEADQUARTERS: 101 N. Sepulveda Blvd., El Segundo, California 90245, USA Tel: (310) 252-7105
 TAC Fax: (310) 252-7903

Visit us at www.irf.com for sales contact information.

Looking for pricing, stock, or lifecycle information?

Click below to explore more details on WIN SOURCE:

 [View IRGS4045DPBF on WIN SOURCE](#)

 [Infineon Technologies](#) Information

Optimize Your Supply Chain with WIN SOURCE Solutions

-  Global Sourcing Solution
-  Obsolete Management
-  Cost Control Management
-  Shortage Management
-  Alternative Solution
-  Excess Inventory Management