



**THE DATASHEET OF  
HT18LG-G**



## Electronic Telephone Line Switch

### Features

- ▶ 350V breakdown voltage
- ▶ 18Ω maximum switch resistance
- ▶ Current limiting protection
- ▶ Operates at 2.3V input

### Applications

- ▶ Telephone handsets
- ▶ Modems
- ▶ Fax machines
- ▶ Answering machines
- ▶ Remote meter reading
- ▶ Telephone interface products

### General Description

The Supertex HT18LG is an electronic line switch circuit that replaces the mechanical hook switch contact or a discrete hook switch in a telephone handset or modem. It switches the positive side of the telephone line using control inputs that are referenced to the negative side of the line. In its off state, it can withstand 350V on the positive input. In its on state, it has a maximum series resistance of 18Ω.

The device provides current limiting determined by an external resistor. There are three control inputs. The HKS pin turns on the hook switch when connected to the TPG pin. This can be accomplished by using a mechanical switch which closes when the handset is physically off-hook. The LS pin allows a logic signal to turn on the hook switch. The dial pulse, Pin 6, is used to turn the hook switch off for pulse dialing. The dial pulse ( $\overline{DP}$ ) is active high.

### Typical Application Circuit

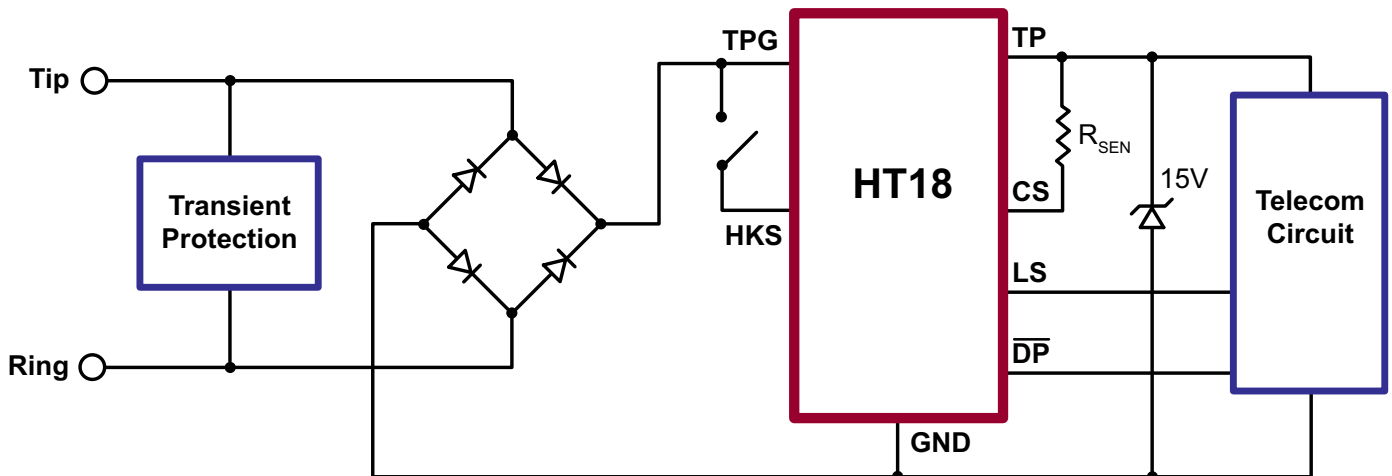

Ordering Information

Part Number	Package	Packing
HT18LG-G	8-Lead SOIC (Narrow Body)	2500/Reel

-G denotes a lead (Pb)-free / RoHS compliant package

Absolute Maximum Ratings

Parameter	Value
$V_{TPG}$ , Input line voltage	+350V
$V_{TP}$ , Output line voltage	+18V
$\overline{DP}$ continuous input voltage	+10V
Operating temperature range	0°C to +50°C
Storage temperature range	-65°C to +150°C
Power dissipation	0.8W

Absolute Maximum Ratings are those values beyond which damage to the device may occur. Functional operation under these conditions is not implied. Continuous operation of the device at the absolute rating level may affect device reliability. All voltages are referenced to device ground.

Pin Configuration

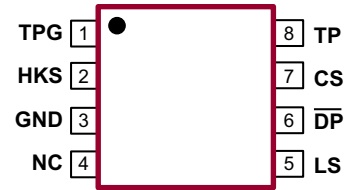

8-Lead SOIC (Narrow Body)  
(top view)

Product Marking



YY = Year Sealed  
 WW = Week Sealed  
 L = Lot Number  
 \_\_\_\_\_ = "Green" Packaging

Package may or may not include the following marks: Si or

8-Lead SOIC (Narrow Body)

Typical Thermal Resistance

Package	$\theta_{ja}$
8-Lead SOIC (Narrow Body)	101°C/W

Electrical Characteristics ( $T_A = 25^\circ\text{C}$  unless otherwise specified)

Sym	Parameter	Min	Typ	Max	Units	Conditions
$V_{TPG}$	High voltage positive supply	-	-	350	V	$I_{TPG} = 500\mu\text{A}$ , HKS, LS, $\overline{DP}$ = open circuit
$I_{TPG}$	Input leakage current	-	-	2.0	$\mu\text{A}$	$V_{TPG} = 100\text{V}$ , HKS, LS, $\overline{DP}$ = open circuit
		-	-	200		$V_{TPG} = 290\text{V}$ , HKS, LS, $\overline{DP}$ = open circuit
$R_{SW}$	TPG to TP switch resistance	-	-	18	$\Omega$	$V_{TPG} = 17\text{V}$ , $I_{TPG} = 180\text{mA}$ , SW = on
		-	-	18		$V_{TPG} = 3.0\text{V}$ , $I_{TPG} = 20\text{mA}$ , SW = on
		-	-	30		$V_{TPG} = 2.3\text{V}$ , $I_{TPG} = 5.0\text{mA}$ , SW = on
$I_{TPG} - I_{TP}$	Bias current	-	-	75	$\mu\text{A}$	$V_{TPG} = 5.0\text{V}$ , SW = on
		-	-	100		$V_{TPG} = 10\text{V}$ , SW = on
$I_{LIM}$	$I_{TPG}$ current limiting	188	250	330	mA	$R_{EXT} = 200\Omega \pm 1\%$
$I_{HKS}$	HKS input current	-	-	200	$\mu\text{A}$	$V_{HKS} = 40$ to $70\text{V}$
$I_{LS}, I_{DP}$	LS and $\overline{DP}$ logic input current	-	-	30	$\mu\text{A}$	$V_{LS} = 3.0\text{V}$ , $V_{DP} = 3.0\text{V}$
$V_{IL(HKS)}$	HKS input low	0	-	0.2	V	$V_{TPG} = 3.0$ to $70\text{V}$
$V_{IH(HKS)}$	HKS input high	2.0	-	$V_{TPG}$	V	$V_{TPG} = 3.0$ to $70\text{V}$
$V_{IL(LS)}, V_{IL(DP)}$	Input logic low for $\overline{DP}$ and LS	0	-	0.2	V	$V_{TPG} = 3.0$ to $70\text{V}$
$V_{IH(LS)}, V_{IH(DP)}$	Input logic high for $\overline{DP}$ and LS	1.5	-	10	V	$V_{TPG} = 3.0$ to $70\text{V}$
$T_{ON}$	Turn-on time	-	-	1.0	ms	$V_{TPG} = 4.5\text{V}$
$T_{OFF}$	Turn-off time	-	-	1.0	ms	$V_{TPG} = 4.5\text{V}$

## Logic Truth Table

HKS	LS	$\overline{DP}$	Switch State
H	L or Z	L or Z	ON
H	H	L or Z	ON
L or Z	L or Z	L or Z	OFF
L or Z	H	L or Z	ON
X	X	H	OFF

Z = high impedance, open circuit

X = irrelevant

L = logic level low

H = logic level high

## Block Diagram

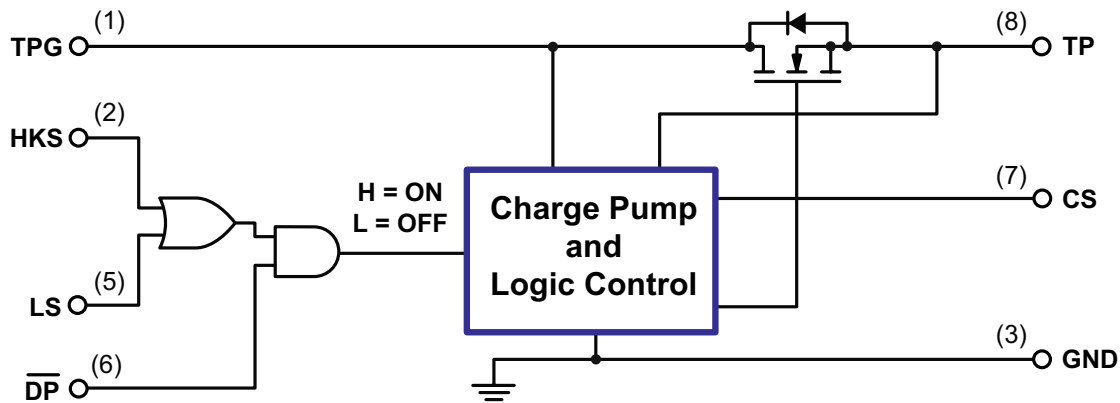

## Pin Description

Pin	Name	Description
1	TPG	Positive input side of a telephone line, typically tip side.
2	HKS	Hookswitch input. Connect HKS to TPG to turn on the hook switch. Internally pulled low with a high value resistor.
3	GND	Device ground. Negative side of a telephone line, typically ring side.
4	NC	No connect. Open circuit. No internal connections to the device.
5	LS	Line switch input. Input logic high turns on the hook switch. Internally pulled low with a high value resistor.
6	$\overline{DP}$	Dial pulse input. Input logic high turns off the hook switch. Used for pulse dialing. Internally pulled low with a high value resistor.
7	CS	Current sense input. An external resistor connected between CS and TP sets the current limit.
8	TP	Positive output side of a telephone line. Zener protection to prevent this output from rising above 18V is required.

# 8-Lead SOIC (Narrow Body) Package Outline (LG)

4.90x3.90mm body, 1.75mm height (max), 1.27mm pitch

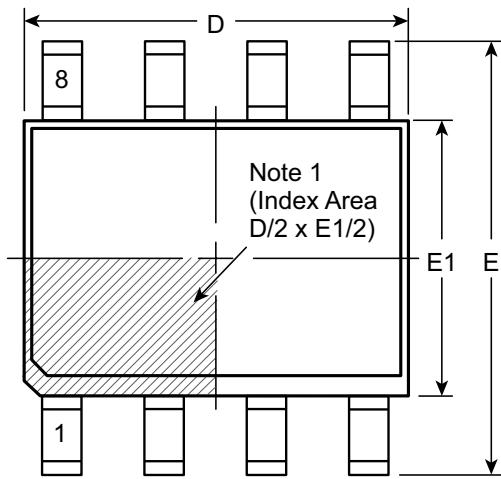

**Top View**

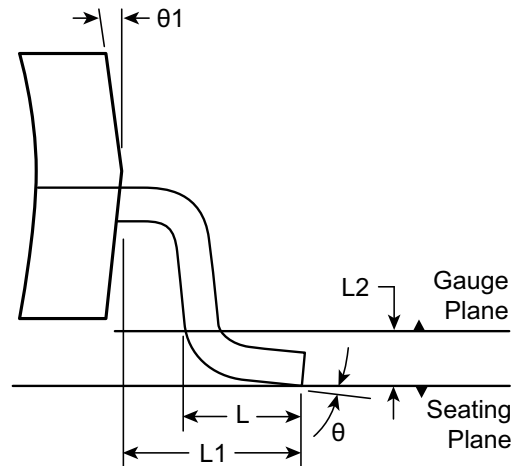

**View B**

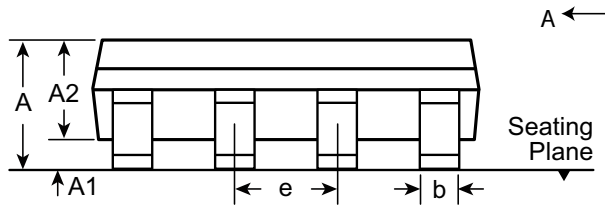

**Side View**

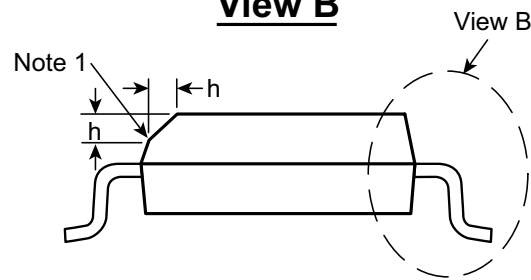

**View A-A**

**Note:**  
 1. This chamfer feature is optional. A Pin 1 identifier must be located in the index area indicated. The Pin 1 identifier can be: a molded mark/identifier; an embedded metal marker; or a printed indicator.

Symbol	A	A1	A2	b	D	E	E1	e	h	L	L1	L2	θ	θ1	
Dimension (mm)	MIN	1.35*	0.10	1.25	0.31	4.80*	5.80*	3.80*	1.27 BSC	0.25	0.40	1.04 REF	0.25 BSC	0°	5°
	NOM	-	-	-	-	4.90	6.00	3.90		-	-			-	-
	MAX	1.75	0.25	1.65*	0.51	5.00*	6.20*	4.00*		0.50	1.27			8°	15°

JEDEC Registration MS-012, Variation AA, Issue E, Sept. 2005.

\* This dimension is not specified in the JEDEC drawing.

Drawings are not to scale.

Supertex Doc. #: DSPD-8SOLGTG, Version I041309.

(The package drawing(s) in this data sheet may not reflect the most current specifications. For the latest package outline information go to <http://www.supertex.com/packaging.html>.)

**Supertex inc.** does not recommend the use of its products in life support applications, and will not knowingly sell them for use in such applications unless it receives an adequate "product liability indemnification insurance agreement." **Supertex inc.** does not assume responsibility for use of devices described, and limits its liability to the replacement of the devices determined defective due to workmanship. No responsibility is assumed for possible omissions and inaccuracies. Circuitry and specifications are subject to change without notice. For the latest product specifications refer to the **Supertex inc.** (website: <http://www.supertex.com>)

## Looking for pricing, stock, or lifecycle information?

Click below to explore more details on WIN SOURCE:

- ⊖ [View HT18LG-G on WIN SOURCE](#)
- ⊖ [Microchip Technology](#) Information

## Optimize Your Supply Chain with WIN SOURCE Solutions

- ✓ Global Sourcing Solution
- ✓ Obsolete Management
- ✓ Cost Control Management
- ✓ Shortage Management
- ✓ Alternative Solution
- ✓ Excess Inventory Management