



**THE DATASHEET OF  
HIP1011CB-T**



## HIP1011

PCI Hot Plug Controller

**NOT RECOMMENDED FOR NEW DESIGNS  
NO RECOMMENDED REPLACEMENT  
contact our Technical Support Center at  
1-888-INTERSIL or www.intersil.com/tsc**

FN4311  
Rev 9.00  
March 2004

The HIP1011 is the PCI Hot Plug voltage bus control IC for use in modern computer systems that facilitates hot plugging of adapter cards into and out of an active or passive back plane. Along with discrete power MOSFETs and a few passive components, the HIP1011 creates a small and simple yet complete power control solution. Four independent supplies are controlled, +5V, +3.3V, +12V, and -12V. The +12V and -12V switches are integrated. For the +5V and +3.3V supplies, overcurrent protection is provided by sensing the voltage across external current-sense resistors. For the +12V and -12V supplies, overcurrent protection is provided internally. In addition, an on-chip reference is used to monitor the +5V, +3.3V and +12V outputs for undervoltage conditions. The PWRON input controls the state of the switches. During an overcurrent condition on any output, or an undervoltage condition on the +5V, +3.3V or +12V outputs, all MOSFETs are immediately latched-off and a LOW (0V) is asserted on the FLTN output. The FLTN latch is cleared when the PWRON input is toggled low again. During initial power-up of the main V<sub>CC</sub> supply (+12V), the PWRON input is inhibited from turning on the switches, and the latch is held in the Reset state until the V<sub>CC</sub> input is greater than 10V.

User programmability of the overcurrent threshold and turn-on slew rate is provided. A resistor connected to the OCSET pin programs the overcurrent threshold. Capacitors connected to the gate pins set the turn-on rate. Also, a capacitor may be added to the FLTN pin to provide noise immunity.

### Ordering Information

| PART NUMBER          | TEMP. RANGE (°C)    | PACKAGE                 | PKG. DWG. # |
|----------------------|---------------------|-------------------------|-------------|
| HIP1011CB            | 0 to 70             | 16 Ld SOIC              | M16.15      |
| HIP1011CB-T          | 0 to 70             | Tape and Reel           |             |
| HIP1011CBZA (Note)   | 0 to 70             | 16 Ld SOIC (Pb-free)    | M16.15      |
| HIP1011CBZA-T (Note) | 0 to 70             | Tape and Reel (Pb-free) |             |
| HIP1011EVAL1         | Evaluation Platform |                         |             |

NOTE: Intersil Pb-free products employ special Pb-free material sets; molding compounds/die attach materials and 100% matte tin plate termination finish, which is compatible with both SnPb and Pb-free soldering operations. Intersil Pb-free products are MSL classified at Pb-free peak reflow temperatures that meet or exceed the Pb-free requirements of IPC/JEDEC J Std-020B.

### Features

- Controls Distribution of Four Supplies: +5V, +3.3V, +12V, and -12V
- Internal MOSFET Switches for +12V and -12V Outputs
- Microprocessor Interface for On/Off Control and Fault Reporting
- Adjustable Overcurrent Protection for All Supplies
- Provides Fault Isolation
- Adjustable Turn-On Slew Rate
- Minimum Parts Count Solution
- No Charge Pump
- Pb-Free Package Options

### Applications

- PCI Hot Plug
- CompactPCI

### Pinout

HIP1011  
(SOIC)  
TOP VIEW

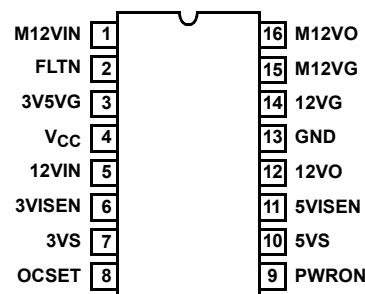

**Typical Application**

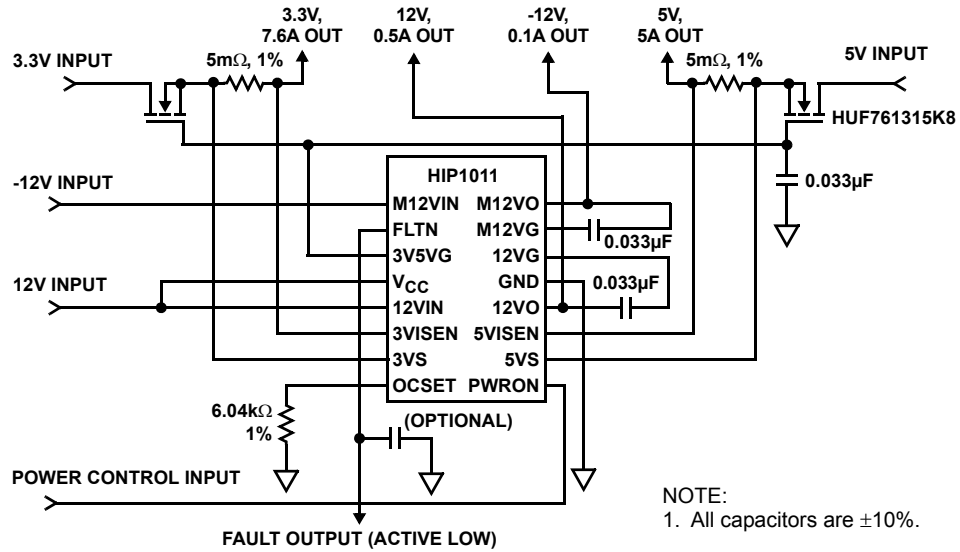

**Simplified Schematic**

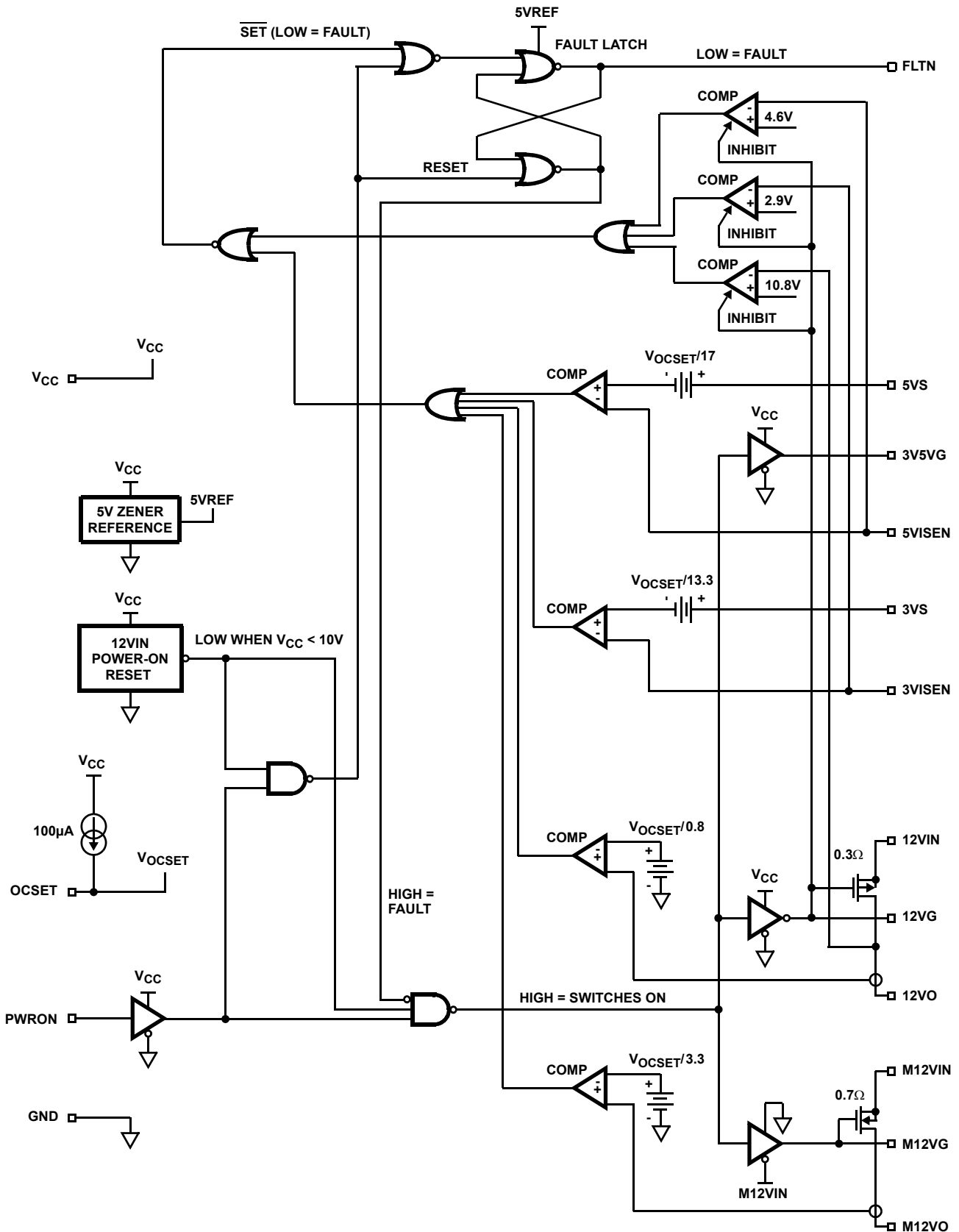

## Pin Descriptions

| PIN | DESIGNATOR | FUNCTION                  | DESCRIPTION   |
|-----|------------|---------------------------|---|
| 1   | M12VIN     | -12V Input                | -12V Supply Input. Also provides power to the -12V overcurrent circuitry.   |
| 2   | FLTN       | Fault Output              | 5V CMOS Fault Output; LOW = FAULT. An optional capacitor may be place from this pin to ground to provide additional immunity from power supply glitches.  |
| 3   | 3V5VG      | 3.3V/5V Gate Output       | Drive the gates of the 3.3V and 5V MOSFETs. Connect a capacitor to ground to set the startup ramp. During turn on, this capacitor is charged with a 25 $\mu$ A current source.  |
| 4   | VCC        | 12V V <sub>CC</sub> Input | Connect to unswitched 12V supply.   |
| 5   | 12VIN      | 12V Input                 | Switched 12V supply input.  |
| 6   | 3VISEN     | 3.3V Current Sense        | Connect to the load side of the current sense resistor in series with source of external 3.3V MOSFET.   |
| 7   | 3VS        | 3.3V Source               | Connect to source of 3.3V MOSFET. This connection along with pin 6 (3VISEN) senses the voltage drop across the sense resistor.  |
| 8   | OCSET      | Overcurrent Set           | Connect a resistor from this pin to ground to set the overcurrent trip point of all four switches. All four over current trips can be programmed by changing the value of this resistor. The default (6.04k $\Omega$ , 1%) is compatible with the maximum allowable currents as outlined in the PCI specification.  |
| 9   | PWRON      | Power On Control          | Controls all four switches. High to Turn Switches ON, Low to turn them OFF.   |
| 10  | 5VS        | 5V Source                 | Connect to source of 5V MOSFET switch. This connection along with pin 11(5VISEN) senses the voltage drop across the sense resistor.   |
| 11  | 5VISEN     | 5V Current Sense          | Connect to the load side of the current sense resistor in series with source of external 5V MOSFET.   |
| 12  | 12VO       | Switched 12V Output       | Switched 12V output.  |
| 13  | GND        | Ground                    | Connect to common of power supplies.  |
| 14  | 12VG       | Gate of Internal PMOS     | Connect a capacitor between 12VG and 12VO to set the startup ramp for the +12V supply. This capacitor is charged with a 25 $\mu$ A current source during startup. The 3.3V and 5V UV circuitry is enabled after the voltage on 12VG is less than 400mV. Therefore, if the capacitor on the pin 3 (3V5VG) is more than 25% larger than the capacitor on pin 14 (12VG) a false UV may be detected during startup. |
| 15  | M12VG      | Gate of Internal NMOS     | Connect a capacitor between M12VG and M12VO to set the startup ramp for the M12V supply. This capacitor is charged with 25 $\mu$ A during startup.  |
| 16  | M12VO      | Switched -12V Output      | Switched 12V Output.  |

**Absolute Maximum Ratings**

|                         |   |
|-------------------------|---|
| V <sub>CC</sub> , 12VIN | -0.5V to +14.0V                                 |
| 12VO                    | -0.5V to V <sub>12VIN</sub> +0.5V               |
| 12VO, 12VG, 3V5VG       | -0.5V to V <sub>CC</sub> +0.5V                  |
| M12VIN                  | -15.0V to +0.5V                                 |
| M12VO, M12VG            | V <sub>M12VIN</sub> -0.5V to +0.5V              |
| 3VISEN, 5VISEN          | -0.5V to the lesser of V <sub>CC</sub> or +7.0V |
| Voltage, Any Other Pin  | -0.5V to +7.0V                                  |
| 12VO Output Current     | 3A  |
| M12VO Output Current    | 0.8A  |
| ESD Classification      | 4KeV (HBM)                                      |

**Operating Conditions**

|   |                  |
|---|------------------|
| VCC Supply Voltage Range                  | +10.8V to +13.2V |
| ±12V, 5V and 3.3V Input Supply Tolerances | ±10%             |
| 12VO Output Current                       | 0 to +0.5A       |
| M12VO Output Current                      | 0 to +0.1A       |
| Temperature Range (T <sub>A</sub> )       | 0°C to 70°C      |

**CAUTION:** Stresses above those listed in "Absolute Maximum Ratings" may cause permanent damage to the device. This is a stress only rating and operation of the device at these or any other conditions above those indicated in the operational sections of this specification is not implied.

**NOTES:**

1.  $\theta_{JA}$  is measured in free air with the component mounted on a high effective thermal conductivity test board in free air. See Technical Brief 379 for details.
2. All voltages are relative to GND, unless otherwise specified.

**Electrical Specifications**

Nominal 5V and 3.3V Input Supply Voltages,  
V<sub>CC</sub> = 12VIN = 12V, M12VIN = -12V, T<sub>A</sub> = T<sub>J</sub> = 0 to 70°C, Unless Otherwise Specified

| PARAMETER                                     | SYMBOL               | TEST CONDITIONS   | MIN  | TYP  | MAX  | UNITS |
|---|----------------------|---|------|------|------|-------|
| <b>5V/3.3V SUPPLY CONTROL</b>                 |                      |   |      |      |      |       |
| 5V Overcurrent Threshold                      | I <sub>OC5V</sub>    | See Figure 1, Typical Application   | -    | 7.1  | -    | A     |
| 5V Overcurrent Threshold Voltage              | V <sub>OC5V</sub>    | V <sub>OCSET</sub> = 1.2V   | 66   | 72   | 79   | mV    |
| 5V Undervoltage Trip Threshold                | V <sub>5VUV</sub>    |   | 4.42 | 4.6  | 4.75 | V     |
| 5V Undervoltage Fault Response Time           | t <sub>5VUV</sub>    |   | -    | 150  | 350  | ns    |
| 5V Turn-On Time (PWRON High to 5VOUT = 4.75V) |                      | C <sub>3V5VG</sub> = 0.022μF, C <sub>5VOUT</sub> = 2000μF, R <sub>L</sub> = 1Ω    | -    | 6.5  | -    | ms    |
| 5VS Input Bias Current                        | I <sub>B5VS</sub>    | PWRON = High  | -40  | -26  | -20  | μA    |
| 5VISEN Input Bias Current                     | I <sub>B5VISEN</sub> | PWRON = High  | -160 | -140 | -110 | μA    |
| 3V Overcurrent Threshold                      | I <sub>OC3V</sub>    | See Figure 1, Typical Application   | -    | 9.0  | -    | A     |
| 3V Overcurrent Threshold Voltage              | V <sub>OC3V</sub>    | V <sub>OCSET</sub> = 1.2V   | 88   | 95   | 102  | mV    |
| 3V Undervoltage Trip Threshold                | V <sub>3VUV</sub>    |   | 2.74 | 2.86 | 2.97 | V     |
| 3V Undervoltage Fault Response Time           | t <sub>3VUV</sub>    |   | -    | 150  | 350  | ns    |
| 3V Turn-On Time (PWRON High to 3VOUT = 3.00V) |                      | C <sub>3V5VG</sub> = 0.022μF, C <sub>3VOUT</sub> = 2000μF, R <sub>L</sub> = 0.43Ω | -    | 6.5  | -    | ms    |
| 3VS Input Bias Current                        | I <sub>B3VS</sub>    | PWRON = High  | -40  | -26  | -20  | μA    |
| 3VISEN Input Bias Current                     | I <sub>B3VISEN</sub> | PWRON = High  | -160 | -140 | -110 | μA    |
| Gate Output Charge Current                    | I <sub>C3V5VG</sub>  | PWRON = High, V <sub>3V5VG</sub> = 2V   | 22.5 | 25.0 | 27.5 | μA    |
| Gate Turn-On Time (PWRON High to 3V5VG = 11V) | t <sub>ON3V5V</sub>  | C <sub>3V5VG</sub> = 0.1μF  | -    | 280  | 500  | μs    |
| Gate Turn-Off Time                            | t <sub>OFF3V5V</sub> | C <sub>3V5VG</sub> = 0.1μF, 3V5VG from 9.5 V to 1V                                | -    | 13   | 17   | μs    |
| Gate Turn-Off Time                            |                      | C <sub>3V5VG</sub> = 0.022μF, 3V5VG Falling 90% to 10%                            | -    | 2    | -    | μs    |

**Thermal Information**

|  |                               |
|--|-------------------------------|
| Thermal Resistance (Typical, Note 1)     | $\theta_{JA}$ (°C/W)          |
| SOIC Package                             | 68                            |
| Maximum Junction Temperature             | 125°C                         |
| Maximum Storage Temperature Range        | -65°C to 150°C                |
| Maximum Lead Temperature (Soldering 10s) | 300°C (SOIC - Lead Tips Only) |

**Die Characteristics**

|                       |     |
|-----------------------|-----|
| Number of Transistors | 290 |
|-----------------------|-----|

**Electrical Specifications** Nominal 5V and 3.3V Input Supply Voltages,  
 $V_{CC} = 12VIN = 12V$ ,  $M12VIN = -12V$ ,  $T_A = T_J = 0$  to  $70^\circ\text{C}$ , Unless Otherwise Specified **(Continued)**

| PARAMETER                                   | SYMBOL          | TEST CONDITIONS   | MIN  | TYP  | MAX   | UNITS         |
|---|-----------------|---|------|------|-------|---------------|
| <b>+12V SUPPLY CONTROL</b>                  |                 |   |      |      |       |               |
| On Resistance of Internal PMOS              | $r_{DS(ON)12}$  | PWRON = High, $I_D = 0.5A$ , $T_A = T_J = 25^\circ\text{C}$                         | 0.18 | .300 | 0.350 | $\Omega$      |
| Overcurrent Threshold                       | $I_{OC12V}$     | $V_{OCSET} = 1.2V$  | 1.25 | 1.50 | 1.8   | A             |
| 12V Undervoltage Trip Threshold             | $V_{12VUV}$     |   | 10.5 | 10.8 | 11.15 | V             |
| Undervoltage Fault Response Time            | $t_{12VUV}$     |   | -    | 150  | -     | ns            |
| Gate Charge Current                         | $I_{C12VG}$     | PWRON = High, $V_{12VG} = 3V$   | 23.5 | 25.0 | 28.5  | $\mu\text{A}$ |
| Turn-On Time (PWRON High to 12VG = 1V)      | $t_{ON12V}$     | $C_{12VG} = 0.022\mu\text{F}$   | -    | 16   | 20    | ms            |
| Turn-Off Time                               | $t_{OFF12V}$    | $C_{12VG} = 0.1\mu\text{F}$ , 12VG  | -    | 9    | 12    | $\mu\text{s}$ |
| Turn-Off Time                               |                 | $C_{12VG} = 0.022\mu\text{F}$ , 12VG Rising 10% - 90%                               | -    | 3    | -     | $\mu\text{s}$ |
| <b>-12V SUPPLY CONTROL</b>                  |                 |   |      |      |       |               |
| On Resistance of Internal NMOS              | $r_{DS(ON)M12}$ | PWRON = High, $I_D = 0.1A$ ,<br>$T_A = T_J = 25^\circ\text{C}$                      | 0.5  | 0.7  | 0.9   | $\Omega$      |
| Overcurrent Threshold                       | $I_{OCM12V}$    | $V_{OCSET} = 1.2V$  | 0.30 | 0.37 | 0.50  | A             |
| Gate Output Charge Current                  | $I_{CM12VG}$    | PWRON = High, $V_{M12VG} = -4V$   | 22.5 | 25   | 27.5  | $\mu\text{A}$ |
| Turn-On Time (PWRON High to M12VG = -1V)    | $t_{ONM12V}$    | $C_{M12VG} = 0.022\mu\text{F}$  | -    | 160  | 300   | $\mu\text{s}$ |
| Turn-On Time (PWRON High to M12VO = -10.8V) |                 | $C_{M12VG} = 0.022\mu\text{F}$ , $C_{M12VO} = 50\mu\text{F}$ ,<br>$R_L = 120\Omega$ | -    | 16   | -     | ms            |
| Turn-Off Time                               | $t_{OFFM12V}$   | $C_{M12VG} = 0.1\mu\text{F}$ , M12VG  | -    | 18   | 23    | $\mu\text{s}$ |
| Turn-Off Time                               |                 | $C_{M12VG} = 0.022\mu\text{F}$ , M12VG Falling 90% to 10%                           | -    | 3    | -     | $\mu\text{s}$ |
| M12VIN Input Bias Current                   | $I_{BM12VIN}$   | PWRON = High  | -    | 2    | 2.6   | mA            |
| <b>CONTROL I/O PINS</b>                     |                 |   |      |      |       |               |
| Supply Current                              | $I_{VCC}$       |   | 4    | 5    | 5.8   | mA            |
| OCSET Current                               | $I_{OCSET}$     |   | 95   | 100  | 105   | $\mu\text{A}$ |
| Overcurrent Fault Response Time             | $t_{OC}$        |   | -    | 500  | 960   | ns            |
| PWRON Threshold Voltage                     | $V_{THPWRON}$   |   | 0.8  | 1.6  | 2.1   | V             |
| FLTN Output Low Voltage                     | $V_{FLTN,OL}$   | $I_{FLTN} = 2\text{mA}$   | -    | 0.6  | 0.9   | V             |
| FLTN Output High Voltage                    | $V_{FLTN,OH}$   | $I_{FLTN} = 0$ to $-4\text{mA}$   | 3.9  | 4.3  | 4.9   | V             |
| FLTN Output Latch Threshold                 | $V_{FLTN,TH}$   |   | 1.8  | 2.3  | 3     | V             |
| 12V Power On Reset Threshold                | $V_{POR,TH}$    | $V_{CC}$ Voltage Falling  | 9.4  | 10   | 10.6  | V             |

Typical Performance Curves

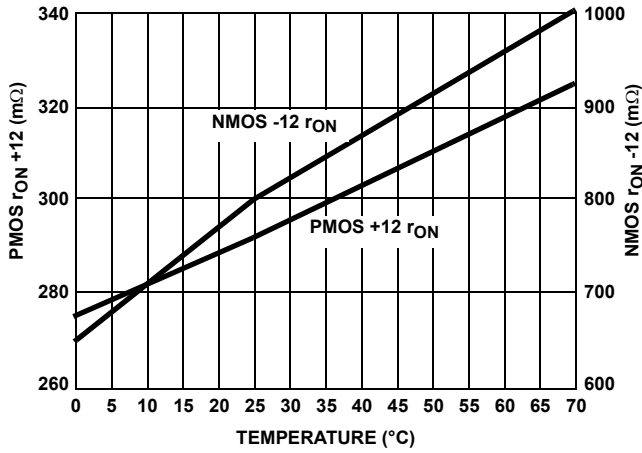

FIGURE 1. r<sub>ON</sub> vs TEMPERATURE

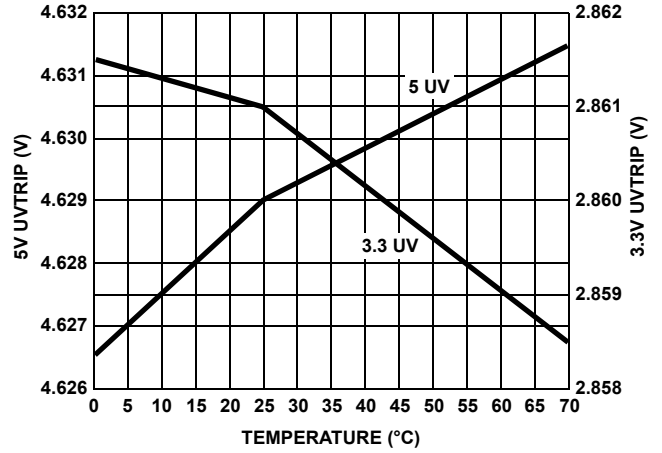

FIGURE 2. UV TRIP vs TEMPERATURE

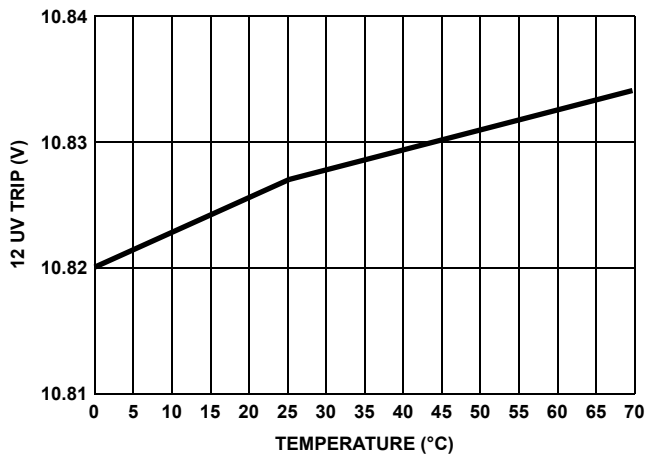

FIGURE 3. 12 UV TRIP vs TEMPERATURE

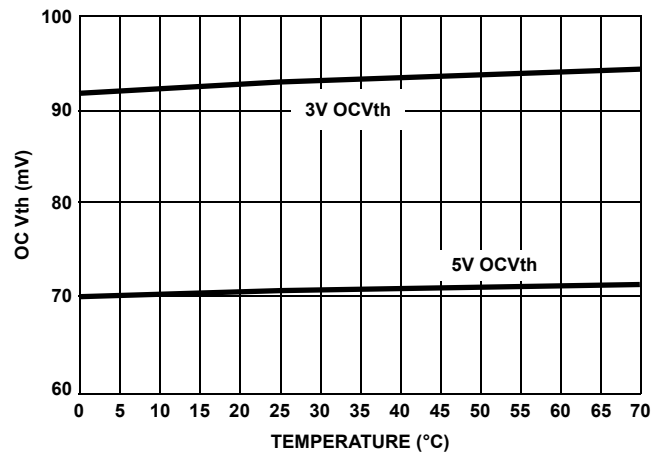

FIGURE 4. OCV<sub>th</sub> vs TEMPERATURE (V<sub>R\_OCSET</sub> = 1.21V)

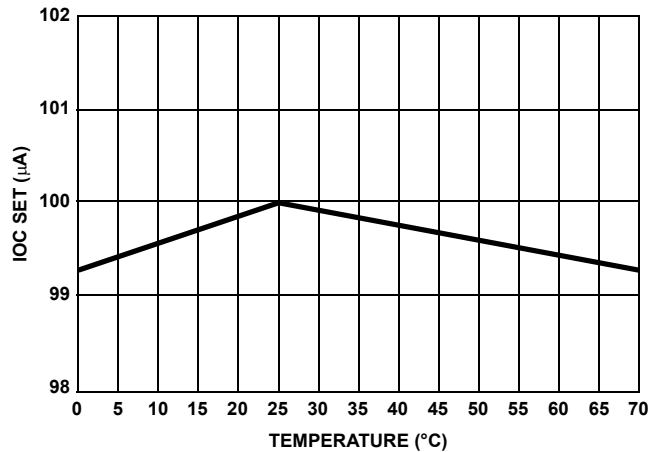
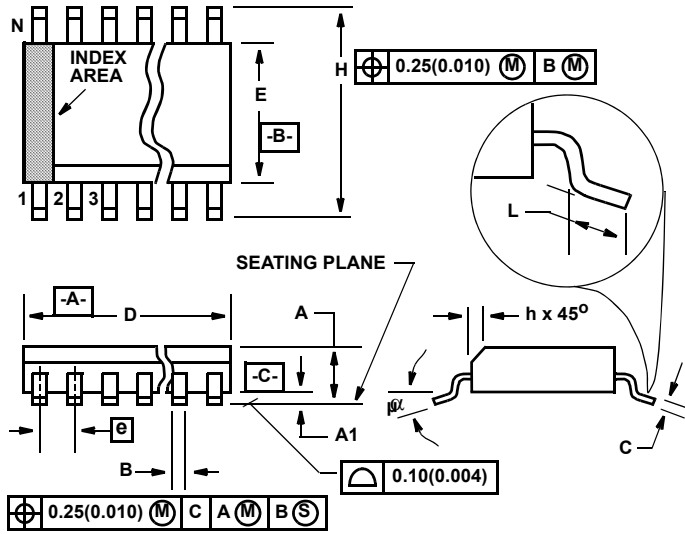

FIGURE 5. OCSET I vs TEMPERATURE

**Small Outline Plastic Packages (SOIC)**



**M16.15 (JEDEC MS-012-AC ISSUE C)  
16 LEAD NARROW BODY SMALL OUTLINE PLASTIC PACKAGE**

| SYMBOL | INCHES    |       | MILLIMETERS |       | NOTES |
|--------|-----------|-------|-------------|-------|-------|
|        | MIN       | MAX   | MIN         | MAX   |       |
| A      | 0.053     | 0.069 | 1.35        | 1.75  | -     |
| A1     | 0.004     | 0.010 | 0.10        | 0.25  | -     |
| B      | 0.014     | 0.019 | 0.35        | 0.49  | 9     |
| C      | 0.007     | 0.010 | 0.19        | 0.25  | -     |
| D      | 0.386     | 0.394 | 9.80        | 10.00 | 3     |
| E      | 0.150     | 0.157 | 3.80        | 4.00  | 4     |
| e      | 0.050 BSC |       | 1.27 BSC    |       | -     |
| H      | 0.228     | 0.244 | 5.80        | 6.20  | -     |
| h      | 0.010     | 0.020 | 0.25        | 0.50  | 5     |
| L      | 0.016     | 0.050 | 0.40        | 1.27  | 6     |
| N      | 16        |       | 16          |       | 7     |
| α      | 0°        | 8°    | 0°          | 8°    | -     |

Rev. 1 02/02

**NOTES:**

1. Symbols are defined in the "MO Series Symbol List" in Section 2.2 of Publication Number 95.
2. Dimensioning and tolerancing per ANSI Y14.5M-1982.
3. Dimension "D" does not include mold flash, protrusions or gate burrs. Mold flash, protrusion and gate burrs shall not exceed 0.15mm (0.006 inch) per side.
4. Dimension "E" does not include interlead flash or protrusions. Interlead flash and protrusions shall not exceed 0.25mm (0.010 inch) per side.
5. The chamfer on the body is optional. If it is not present, a visual index feature must be located within the crosshatched area.
6. "L" is the length of terminal for soldering to a substrate.
7. "N" is the number of terminal positions.
8. Terminal numbers are shown for reference only.
9. The lead width "B", as measured 0.36mm (0.014 inch) or greater above the seating plane, shall not exceed a maximum value of 0.61mm (0.024 inch)
10. Controlling dimension: MILLIMETER. Converted inch dimensions are not necessarily exact.

© Copyright Intersil Americas LLC 2004. All Rights Reserved.

All trademarks and registered trademarks are the property of their respective owners.

For additional products, see [www.intersil.com/en/products.html](http://www.intersil.com/en/products.html)

Intersil products are manufactured, assembled and tested utilizing ISO9001 quality systems as noted in the quality certifications found at [www.intersil.com/en/support/qualandreliability.html](http://www.intersil.com/en/support/qualandreliability.html)

*Intersil products are sold by description only. Intersil may modify the circuit design and/or specifications of products at any time without notice, provided that such modification does not, in Intersil's sole judgment, affect the form, fit or function of the product. Accordingly, the reader is cautioned to verify that datasheets are current before placing orders. Information furnished by Intersil is believed to be accurate and reliable. However, no responsibility is assumed by Intersil or its subsidiaries for its use; nor for any infringements of patents or other rights of third parties which may result from its use. No license is granted by implication or otherwise under any patent or patent rights of Intersil or its subsidiaries.*

For information regarding Intersil Corporation and its products, see [www.intersil.com](http://www.intersil.com)

## Looking for pricing, stock, or lifecycle information?

Click below to explore more details on WIN SOURCE:

 [View HIP1011CB-T on WIN SOURCE](#)

 [Intersil Information](#)

## Optimize Your Supply Chain with WIN SOURCE Solutions

-  Global Sourcing Solution
-  Obsolete Management
-  Cost Control Management
-  Shortage Management
-  Alternative Solution
-  Excess Inventory Management