

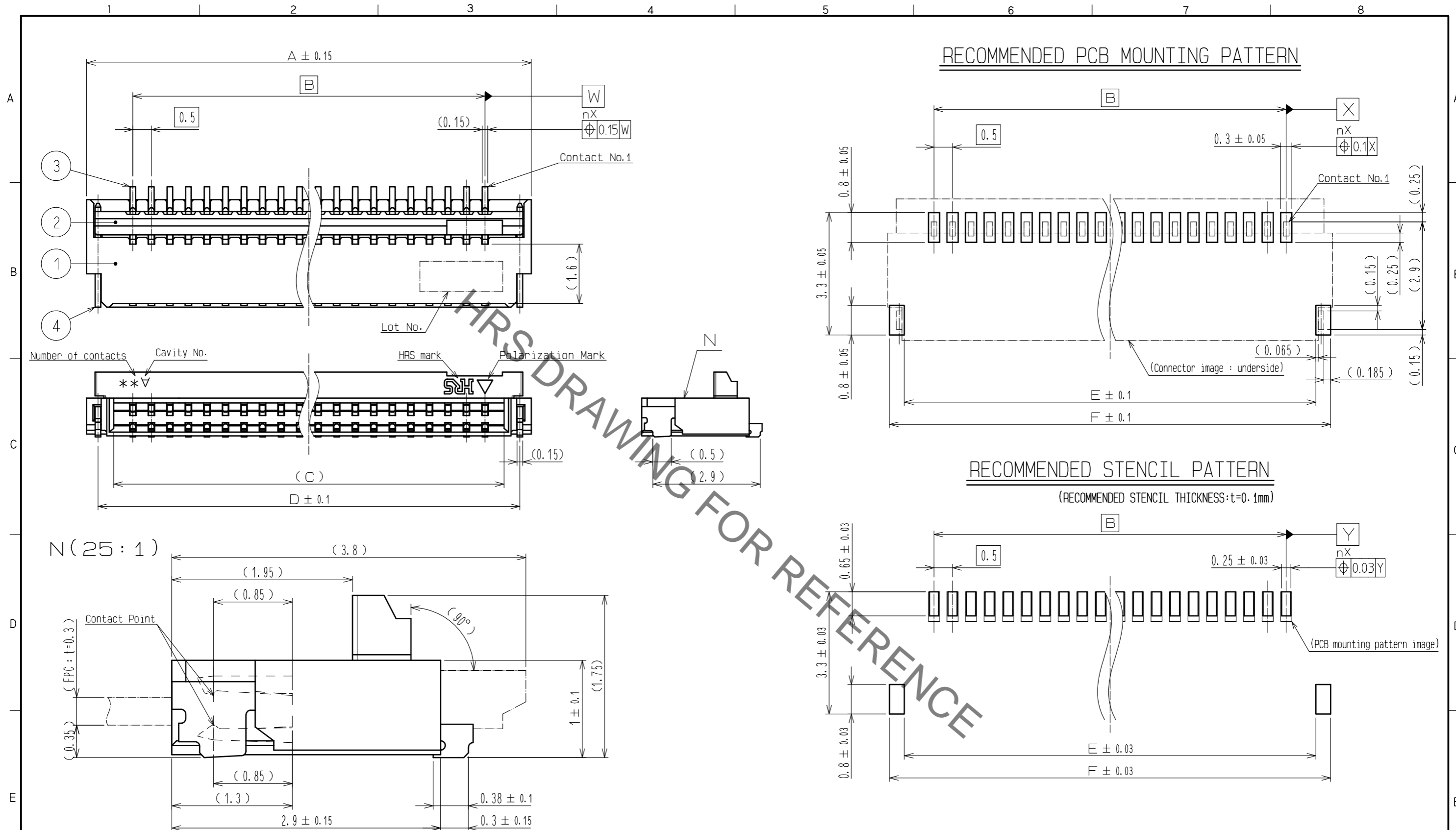

**THE DATASHEET OF
FH34SRJ-22S-0.5SH(50)**



Aug.1.2019 Copyright 2019 HIROSE ELECTRIC CO., LTD. All Rights Reserved.
In case of consideration for using Automotive equipment / device which demand high reliability, kindly contact our sales window correspondents.



- NOTE
- 1 The dimensions in parentheses are for reference.
 - 2 Lead coplanarity including reinforced metal fittings shall be 0.1 MAX.
 - 3 To be delivered with tape and reel packages.
See attached packaging specifications for details.
 - 4 Note that preventive hole for sink mark could be added for improvement.
 - 5 The quality remains good, even with the dark spots, which could occasionally occur on molded plastic.
 - 6 This product satisfies halogen free requirements defined as 900 ppm maximum chlorine, 900 ppm maximum bromine, and 1500 ppm maximum total of chlorine and bromine.
 - 7 Material of the actuator for 8 pos. is LCP, and the material of other positions is Polyamide.
 - 8 'n' represents the number of contacts.

4	PHOSPHOR BRONZE (PLATED MATERIAL)	TIN PLATING (REFLOW FINISHED) 1μMIN OVER COPPER 0.3μMIN	8	(CONNECTOR)	
3	PHOSPHOR BRONZE	(CONTACT AREA LEAD) GOLD PLATING 0.05μMIN OVER NICKEL 1μMIN (OTHER) NICKEL PLATING 1μMIN	7	POLYSTYRENE	
2	LCP/PA <7>	BLACK UL94V-0	6	POLYESTER	
1	LCP	GRAY UL94V-0	5	POLYSTYRENE	
NO.	MATERIAL	FINISH . REMARKS	NO.	MATERIAL	FINISH . REMARKS
UNITS mm		SCALE 10:1	COUNT 1	DESCRIPTION OF REVISIONS DIS-F-00002581	DESIGNED KN. KOBAYASHI
		APPROVED : MO. ISHIDA	13.11.29	DRAWING NO. EDC-159714-50-04	CHECKED HS. SAKAMOTO
HIROSE ELECTRIC CO., LTD.		CHECKED : HS. SAKAMOTO	13.11.29	PART NO. FH34SRJ-*S-0.5SH<50>	DATE 17.08.22
		DESIGNED : YS. EBI	13.11.28	CODE NO. CL580	
		DRAWN : NM. SANPEI	13.11.28		

Aug.1.2019 Copyright 2019 HIROSE ELECTRIC CO., LTD. All Rights Reserved.
In case of consideration for using Automotive equipment / device which demand high reliability, kindly contact our sales window correspondents.

RECOMMENDED FPC PATTERN (20:1)

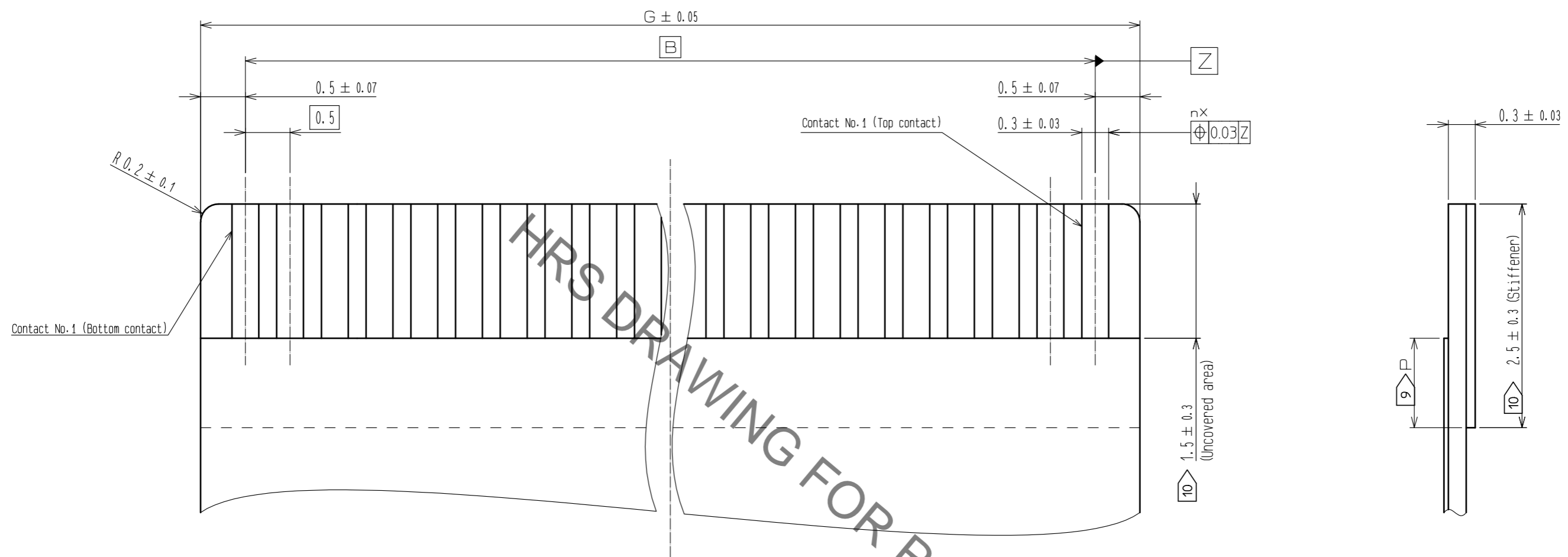

FPC CONFIGURATION (REFERENCE EXAMPLE) (FREE)

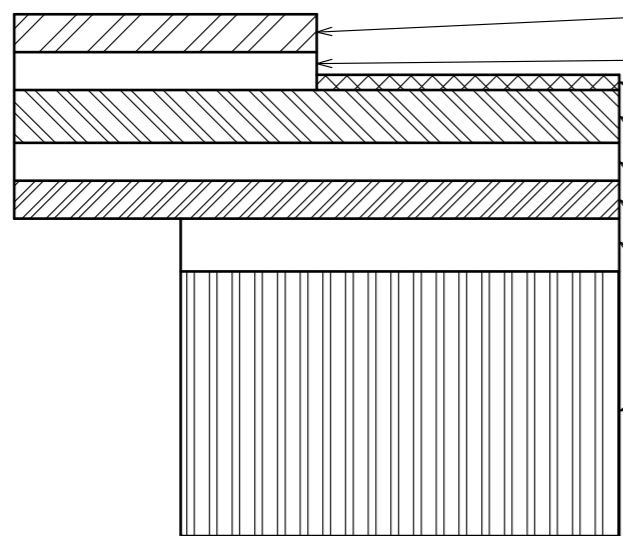

MATERIAL NAME	MATERIAL	THICKNESS(μm)
COVERING FILM LAYER	POLYIMIDE 1 mil	25
COVER ADHESIVE		25
SURFACE TREATMENT	1μm TO 5μm NICKEL UNDERPLATED 0.2μm GOLD PLATED.	(3)
COPPER FOIL	Cu 1 OZ	35
BASE ADHESIVE	HEAT-HARDENED ADHESIVE	25
BASE FILM	POLYIMIDE 1 mil	25
REINFORCEMENT MATERIAL ADHESIVE	HEAT-HARDENED ADHESIVE	35
STIFFENER	POLYIMIDE 7 mil	175

NOTE 9 Dimension P must be 0.5mmMIN.
 10 For the compatibility with FH19SC series connectors(bottom contact).
 Change the length of uncoverd area to be 2.5mm +/-0.3 .
 And the stiffener length to be 3.5mm +/-0.3.
 (The pin numbers will not be compatible)

HRS	DRAWING NO.	EDC-159714-50-04
	PART NO.	FH34SRJ-*S-0.5SH(50)
	CODE NO.	CL580
		4/28

Aug.1.2019 Copyright 2019 HIROSE ELECTRIC CO., LTD. All Rights Reserved.
 In case of consideration for using Automotive equipment / device which demand high reliability, kindly contact our sales window correspondents.

EMBOSSED CARRIER TAPE DIMENSION (2:1)

●24mmMAX

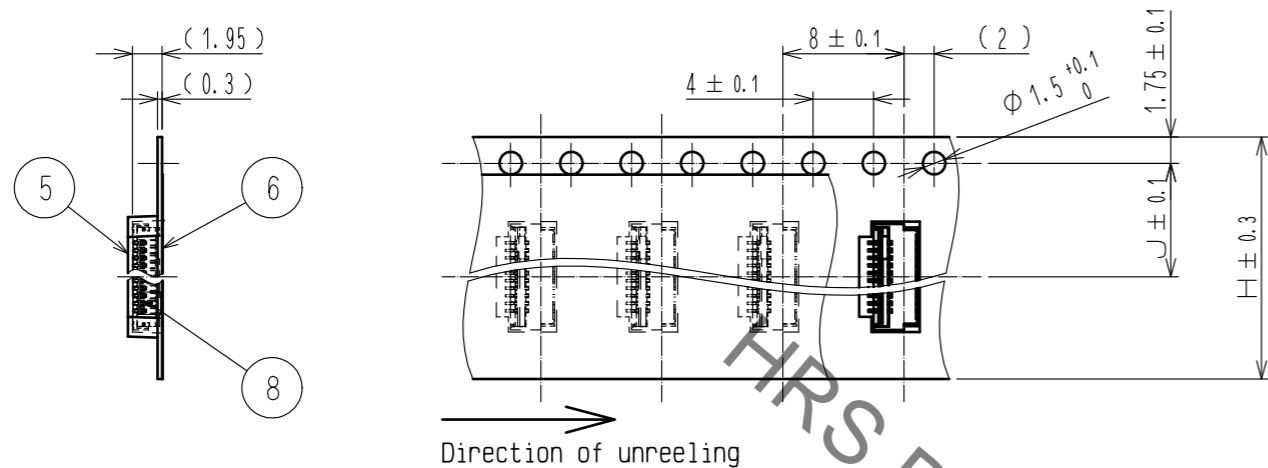

●32mmMIN

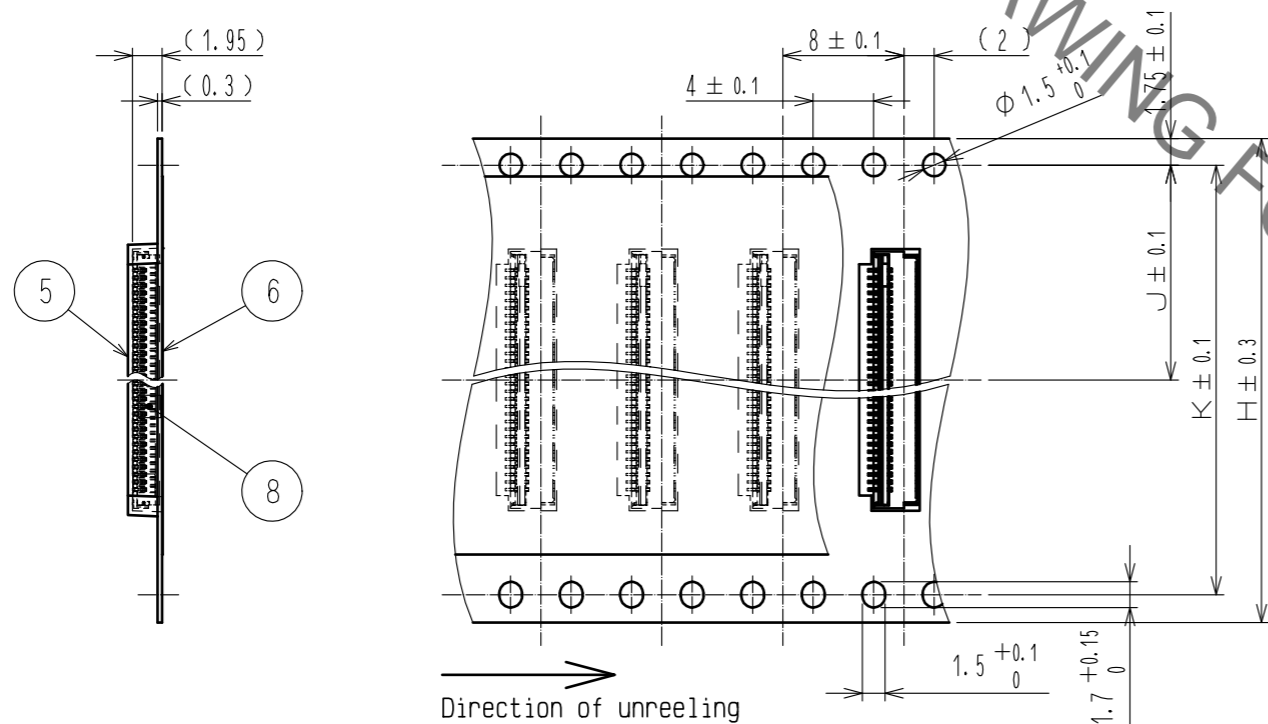

REEL DIMENSION (FREE)

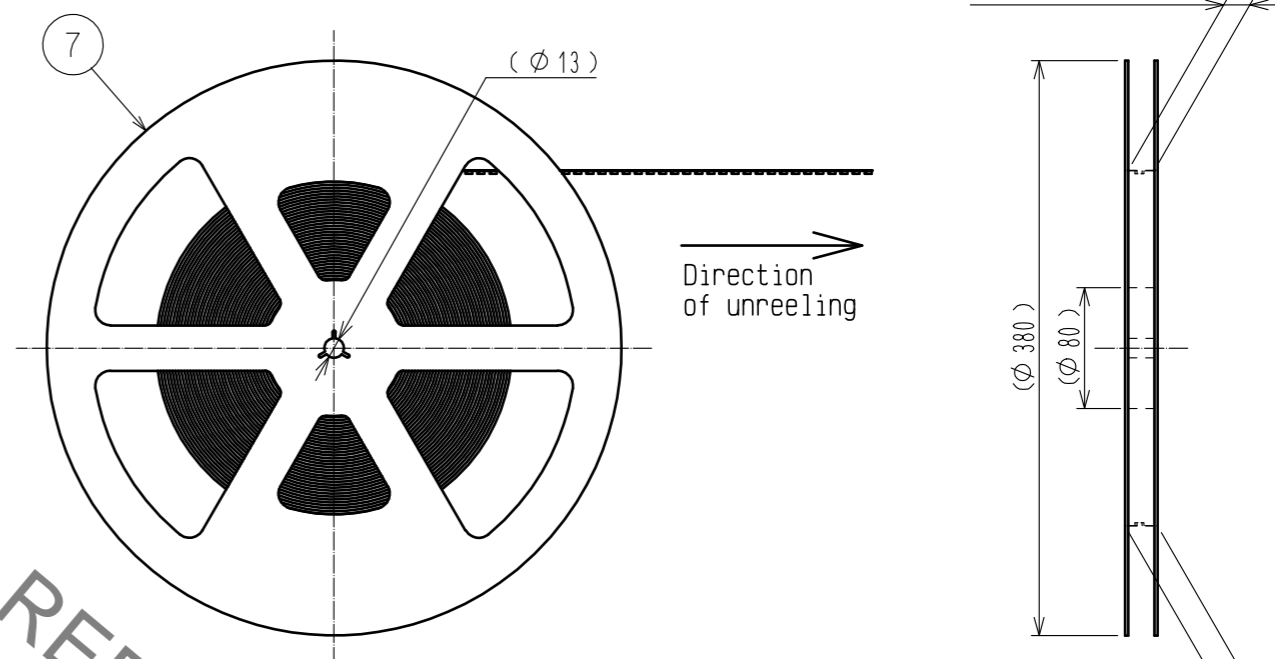

NOTE 11 Per reel : 5000 connectors.
 12 Refer to JIS C 0806 and IEC 60286-3
 (Packaging of components for automatic handling.)

LEADER, TRAILER DIMENSION (FREE)

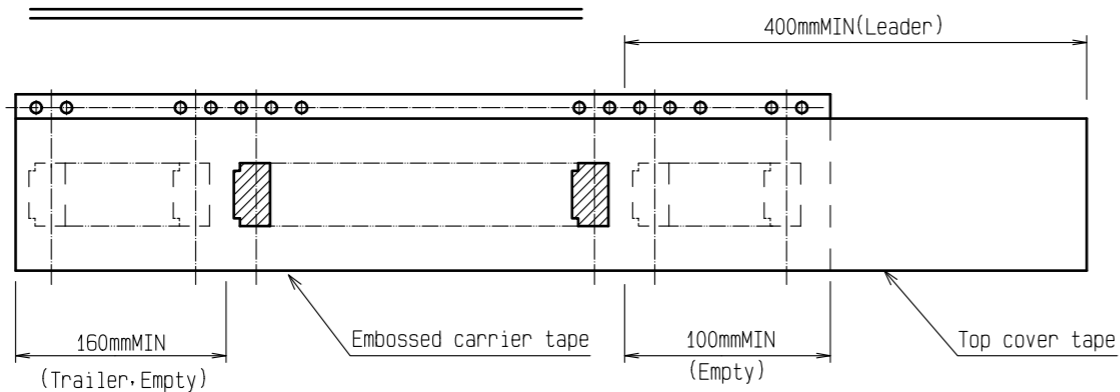

<DRAWING FOR PACKING>

HRS	DRAWING NO.	EDC-159714-50-04
	PART NO.	FH34SRJ-*S-0.5SH(50)
	CODE NO.	CL580
		\triangle 3/8

Aug.1.2019 Copyright 2019 HIROSE ELECTRIC CO., LTD. All Rights Reserved.
 In case of consideration for using Automotive equipment / device which demand high reliability, kindly contact our sales window correspondents.

PART NUMBER	CODE NUMBER	NUMBER OF CONTACTS	DIMENSION OF CONNECTOR, FPC,PCB MOUNTING PATTERN AND STENCIL							DIMENSION OF DRAWING FOR PACKING				
			A	B	C	D	E	F	G	H	J	K	L	M
FH34SRJ-4S-0.5SH(50)	CL580-1238-7-50	4	4	1.5	2.53	3.38	3.1	3.9	2.5	16	7.5	—	17.4	21.4
FH34SRJ-5S-0.5SH(50)	CL580-1264-7-50	5	4.5	2	3.03	3.88	3.6	4.4	3	16	7.5	—	17.4	21.4
FH34SRJ-6S-0.5SH(50)	CL580-1236-1-50	6	5	2.5	3.53	4.38	4.1	4.9	3.5	16	7.5	—	17.4	21.4
FH34SRJ-7S-0.5SH(50)	CL580-1200-0-50	7	5.5	3	4.03	4.88	4.6	5.4	4	16	7.5	—	17.4	21.4
FH34SRJ-8S-0.5SH(50)	CL580-1231-8-50	8	6	3.5	4.53	5.38	5.1	5.9	4.5	16	7.5	—	17.4	21.4
FH34SRJ-9S-0.5SH(50)	CL580-1262-1-50	9	6.5	4	5.03	5.88	5.6	6.4	5	16	7.5	—	17.4	21.4
FH34SRJ-10S-0.5SH(50)	CL580-1251-5-50	10	7	4.5	5.53	6.38	6.1	6.9	5.5	16	7.5	—	17.4	21.4
FH34SRJ-11S-0.5SH(50)	CL580-1258-4-50	11	7.5	5	6.03	6.88	6.6	7.4	6	16	7.5	—	17.4	21.4
FH34SRJ-12S-0.5SH(50)	CL580-1253-0-50	12	8	5.5	6.53	7.38	7.1	7.9	6.5	24	11.5	—	25.4	29.4
FH34SRJ-14S-0.5SH(50)	CL580-1252-8-50	14	9	6.5	7.53	8.38	8.1	8.9	7.5	24	11.5	—	25.4	29.4
FH34SRJ-16S-0.5SH(50)	CL580-1259-7-50	16	10	7.5	8.57	9.38	9.1	9.9	8.5	24	11.5	—	25.4	29.4
FH34SRJ-18S-0.5SH(50)	CL580-1248-0-50	18	11	8.5	9.57	10.38	10.1	10.9	9.5	24	11.5	—	25.4	29.4
FH34SRJ-20S-0.5SH(50)	CL580-1256-9-50	20	12	9.5	10.57	11.38	11.1	11.9	10.5	24	11.5	—	25.4	29.4
FH34SRJ-22S-0.5SH(50)	CL580-1254-3-50	22	13	10.5	11.57	12.38	12.1	12.9	11.5	24	11.5	—	25.4	29.4
FH34SRJ-24S-0.5SH(50)	CL580-1255-6-50	24	14	11.5	12.57	13.38	13.1	13.9	12.5	24	11.5	—	25.4	29.4
FH34SRJ-26S-0.5SH(50)	CL580-1247-8-50	26	15	12.5	13.57	14.38	14.1	14.9	13.5	24	11.5	—	25.4	29.4
FH34SRJ-30S-0.5SH(50)	CL580-1232-0-50	30	17	14.5	15.57	16.38	16.1	16.9	15.5	32	14.2	28.4	33.4	37.4
△ FH34SRJ-32S-0.5SH(50)	CL580-1257-1-50	32	18	15.5	16.53	17.38	17.1	17.9	16.5	32	14.2	28.4	33.4	37.4
FH34SRJ-34S-0.5SH(50)	CL580-1261-9-50	34	19	16.5	17.53	18.38	18.1	18.9	17.5	32	14.2	28.4	33.4	37.4
FH34SRJ-40S-0.5SH(50)	CL580-1260-6-50	40	22	19.5	20.53	21.38	21.1	21.9	20.5	44	20.2	40.4	45.4	49.4
FH34SRJ-45S-0.5SH(50)	CL580-1265-0-50	45	24.5	22	23.03	23.88	23.6	24.4	23	44	20.2	40.4	45.4	49.4
FH34SRJ-50S-0.5SH(50)	CL580-1266-2-50	50	27	24.5	25.53	26.38	26.1	26.9	25.5	44	20.2	40.4	45.4	49.4



HRS	DRAWING NO.	EDC-159714-50-04
	PART NO.	FH34SRJ-*S-0.5SH(50)
	CODE NO.	CL580
		△ 4/8

Aug.1.2019 Copyright 2019 HIROSE ELECTRIC CO., LTD. All Rights Reserved.
In case of consideration for using Automotive equipment / device which demand high reliability, kindly contact our sales window correspondents.

This connector features small, thin and back flip design, requiring delicate and careful handling. To prevent connector/FPC breakage and contact failure (mating failure, FPC pattern breakage, etc), read through the instructions shown below and handle the connector properly. Each values indicating here are for reference and may differ from standard value.

[Operation and Precautions]

1. Initial condition

Actuator does not have to be operated before inserting FPC, as the connector is delivered with the actuator opened.

[Caution]

- Do not close the actuator before inserting FPC.
- Closing the actuator without FPC could make the contact gap smaller, which could increase the FPC insertion force.
- Do not insert FPC or operate actuator before mounting.

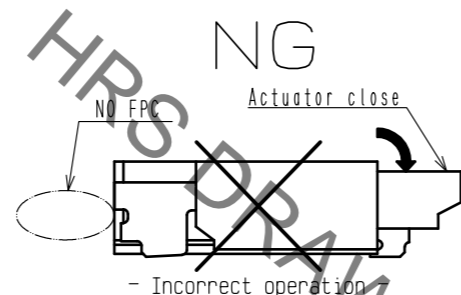
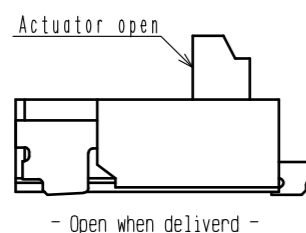

2. How to insert FPC

Insert the FPC into the connector opening horizontally to the PCB plane. Insert it properly to the very end.

[Caution]

- Insert the FPC with the actuator opened.
- Do not twist the FPC to up and down, right and left or an angle.

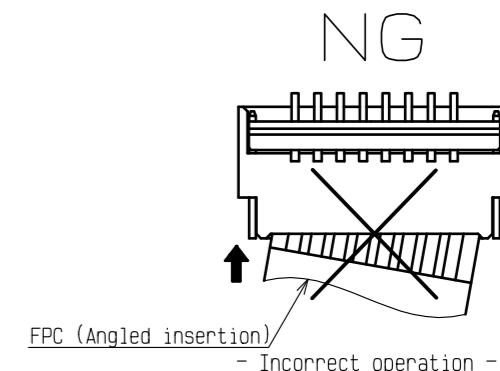
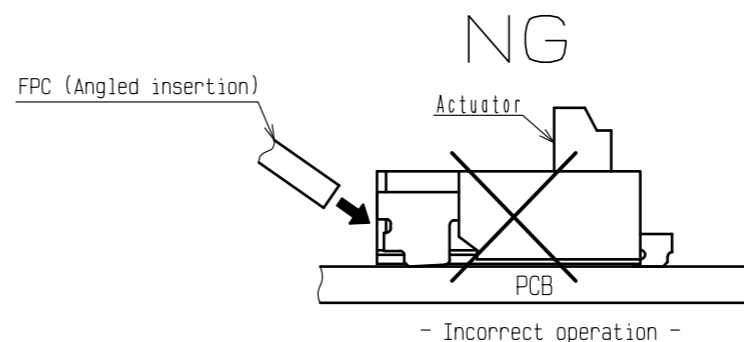
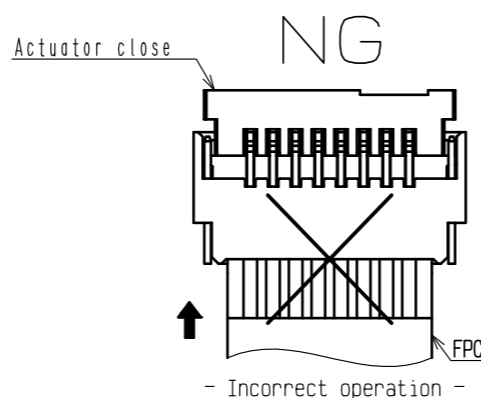
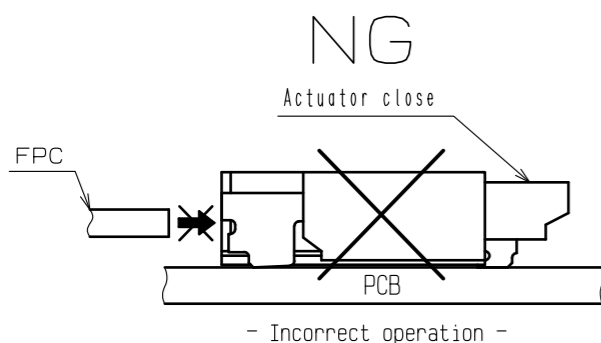
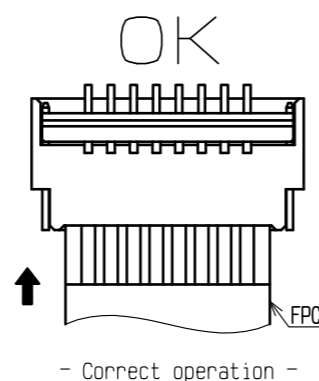
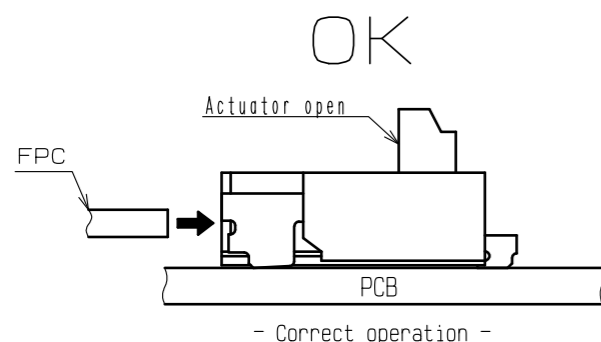

3. FPC insertion check (for using contacts on the top, for FPC pattern only applicable to FH34S*)

Incorrect operation modes are prevented by visual check, comparing positions of housing opening end line and FPC pattern line.

[Caution]

- Do not insert the FPC at an angle and/or stop it before insertion is completed.

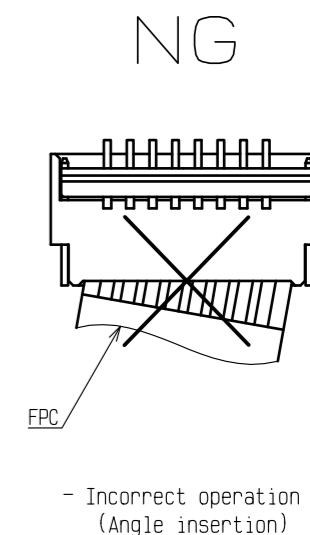
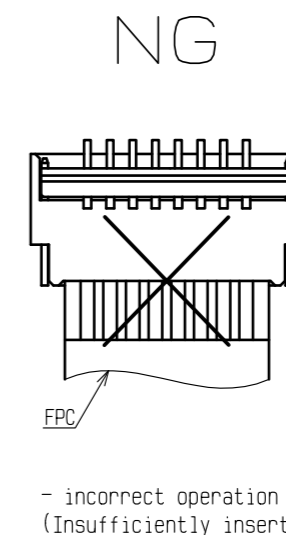
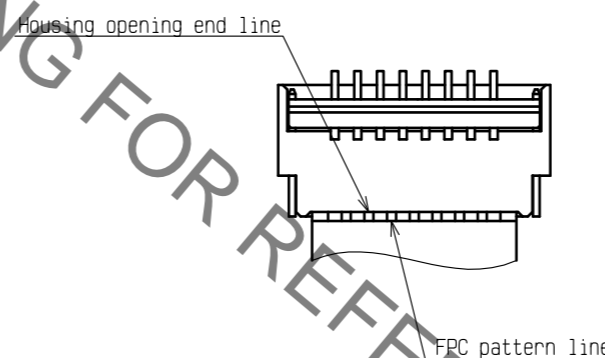

<INSTRUCTION MANUAL (1)>

HRS	DRAWING NO.	EDC-159714-50-04
	PART NO.	FH34SRJ-*S-0.5SH(50)
	CODE NO.	CL580
		4/5/8

Aug.1.2019 Copyright 2019 HIROSE ELECTRIC CO., LTD. All Rights Reserved.
In case of consideration for using Automotive equipment / device which demand high reliability, kindly contact our sales window correspondents.

4. How to lock

Apply load to rotate the actuator by 90 degree after inserting the FPC.

[Caution]

- The actuator rotates around the rotational axis as shown below.
- Do not rotate the actuator to the counter direction.
- Do not pinch or pick the actuator to lift.
- Operate the actuator by hand without using sharp tool such as Tweezers.
- To close the actuator, operate at the center of the actuator.
- To close the actuator, do not operate the actuator at one end only.
- Do not apply excess force to the housing during the operation.

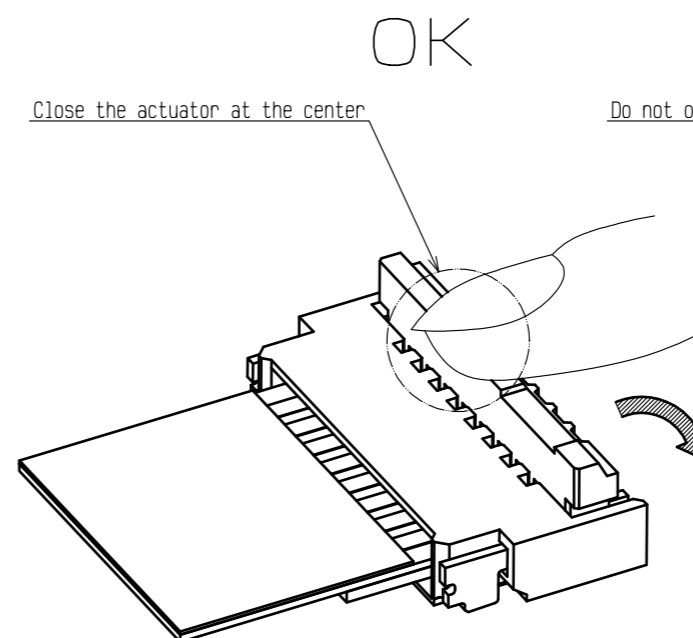
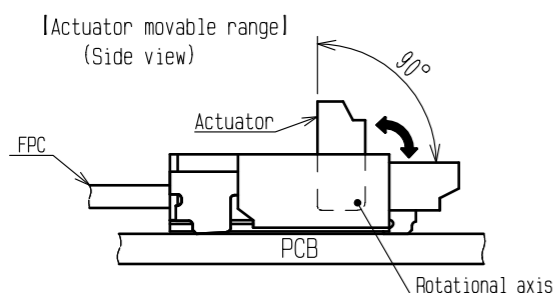

- Correct operation -

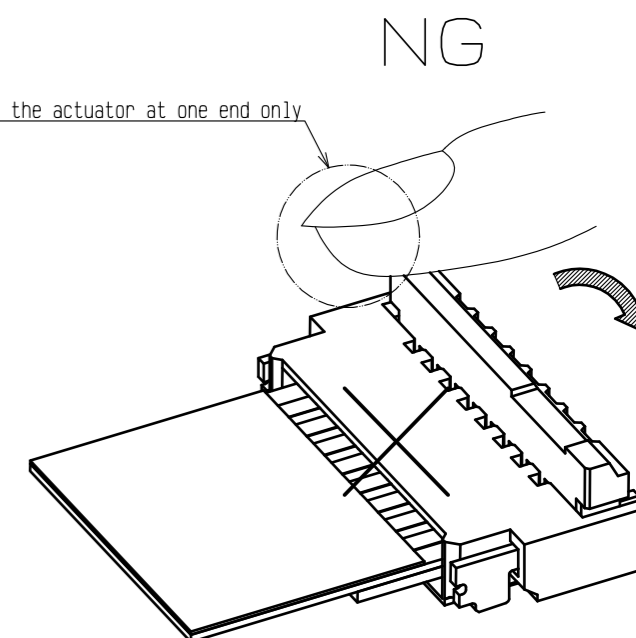

- Incorrect operation -

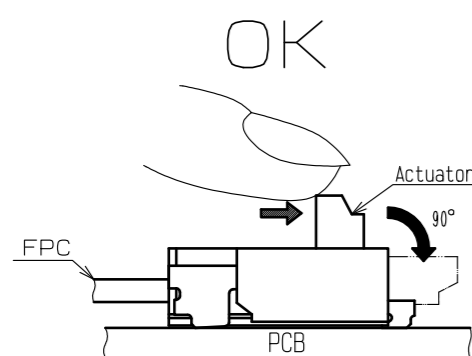

- Correct operation -

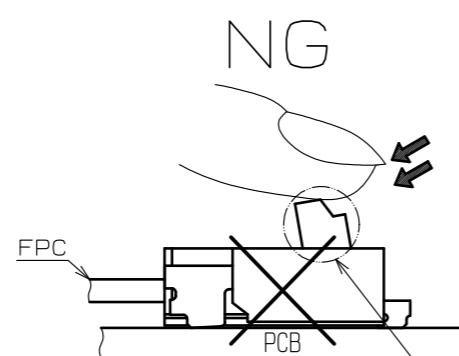

- Incorrect operation -

Actuator receives inappropriate force in reverse direction.

Do not apply excess force to the housing during the operation.

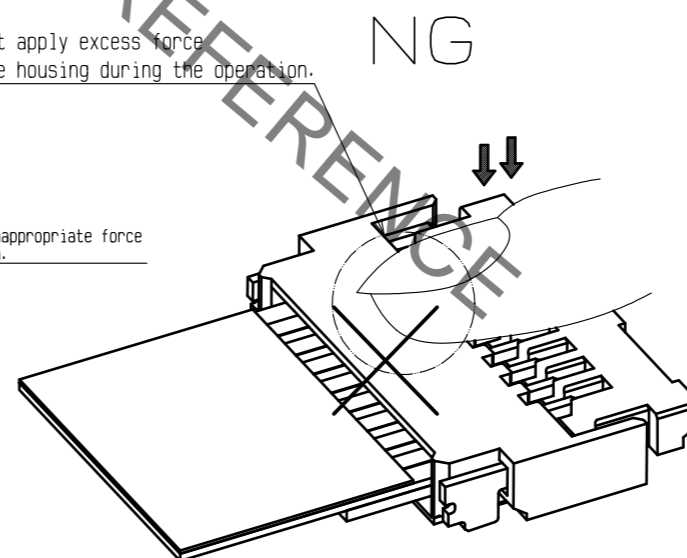

- Incorrect operation -

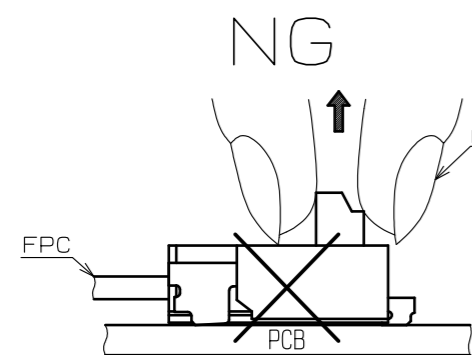

- Incorrect operation -

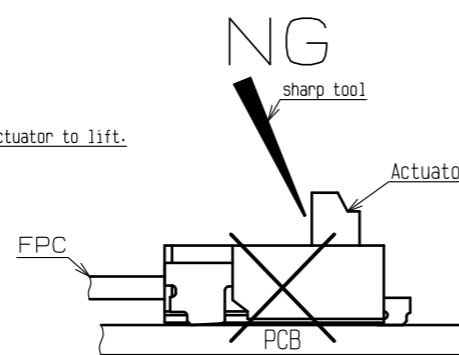

- Incorrect operation -

<INSTRUCTION MANUAL (2)>

HRS

DRAWING NO.	EDC-159714-50-04
PART NO.	FH34SRJ-*S-0.5SH(50)
CODE NO.	CL580

4/6/8

Aug.1.2019 Copyright 2019 HIROSE ELECTRIC CO., LTD. All Rights Reserved.
 In case of consideration for using Automotive equipment / device which demand high reliability, kindly contact our sales window correspondents.

5. How to unlock

Slowly flip up the actuator to release the lock.

[Caution]

- The actuator is opened up to the movable limit, 90 degree. Do not open the actuator beyond the specified degree or apply excess force to the actuator.
- Open the actuator right above. Do not attempt to open further or to open it by applying horizontal force as this may cause its damage.
- Please note that the connector is back flip style connector, and the opening for FPC insertion and the actuator face the opposite direction. Do not try to lift the actuator at the FPC insertion opening side.
- Operate the actuator by hand without using sharp tool such as Tweezers.
- To open the actuator, operate at the center of the actuator.
- To open the actuator, do not operate the actuator at one end only.

Open the actuator at the center

OK

Do not operate the actuator at one end only

NG

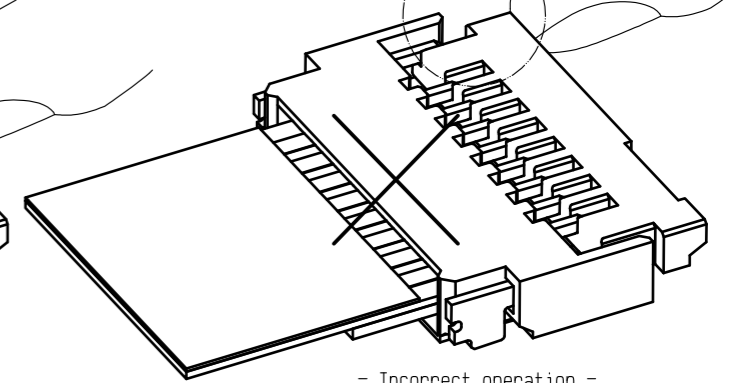
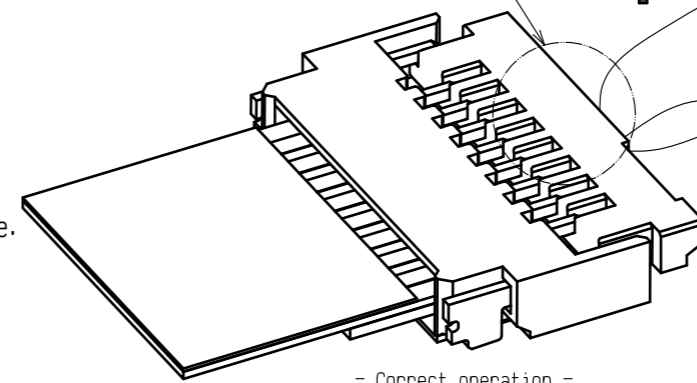

6. How to remove FPC

After rotating the actuator to the fully opened position carefully withdraw the FPC in the direction parallel to the PCB mounting surface.

[Caution]

- For FPC removal, pull out the FPC horizontally without applying stress in vertical and longitudinal directions.
- Do not attempt to pull the FPC without unlocking the actuator.

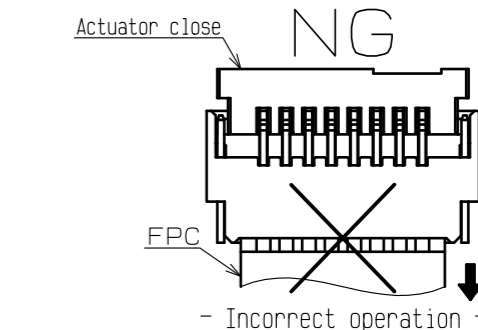
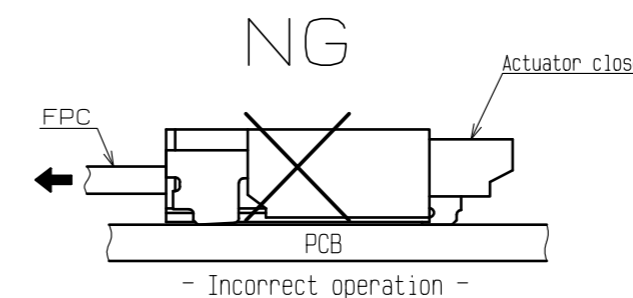
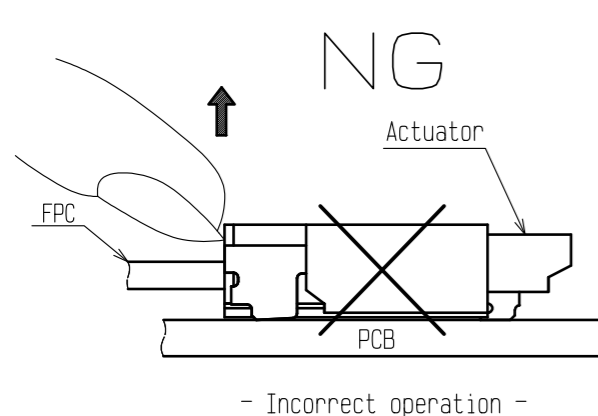
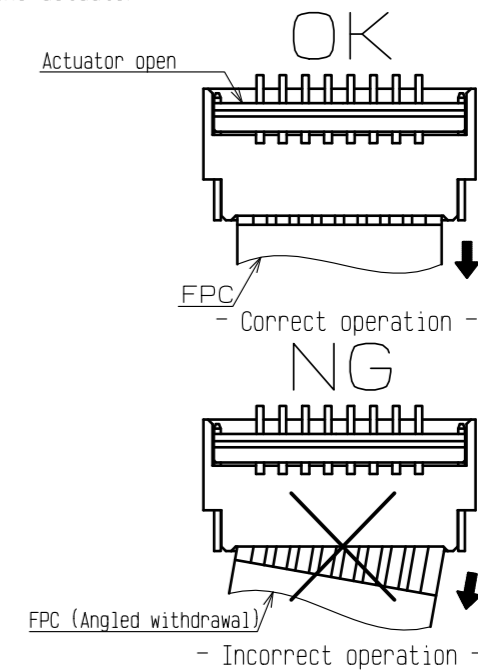
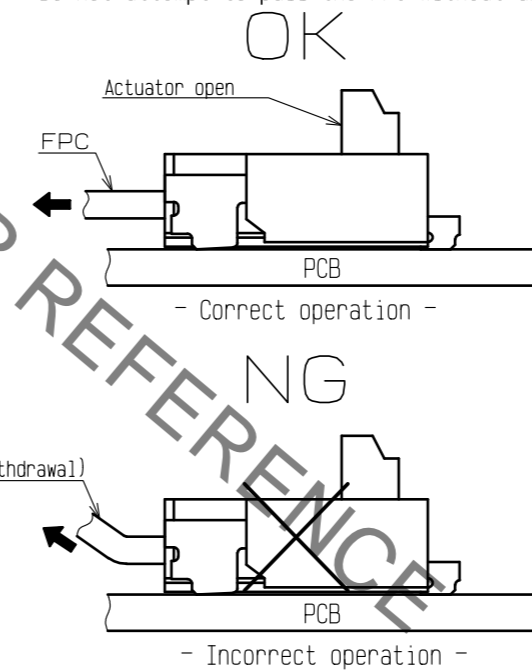
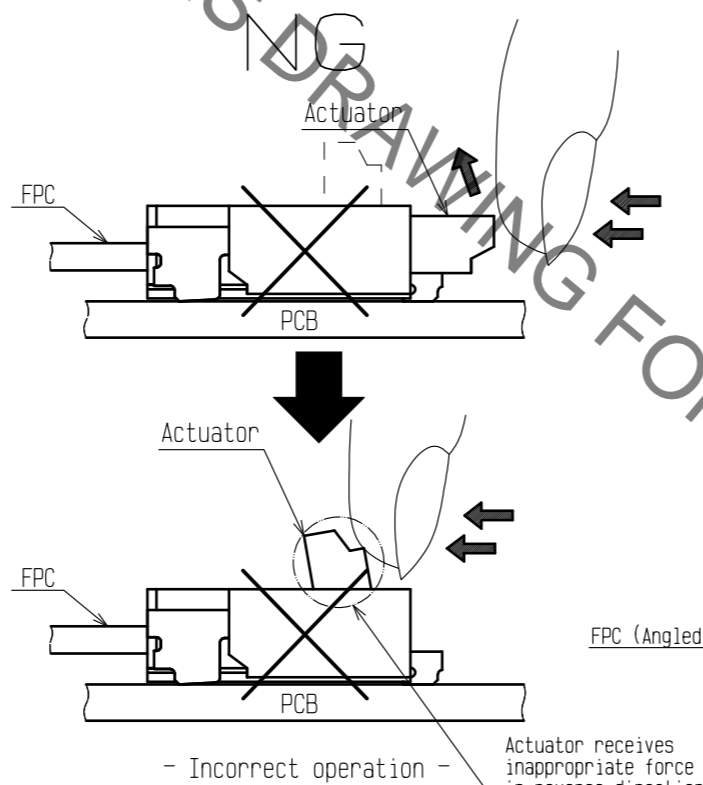
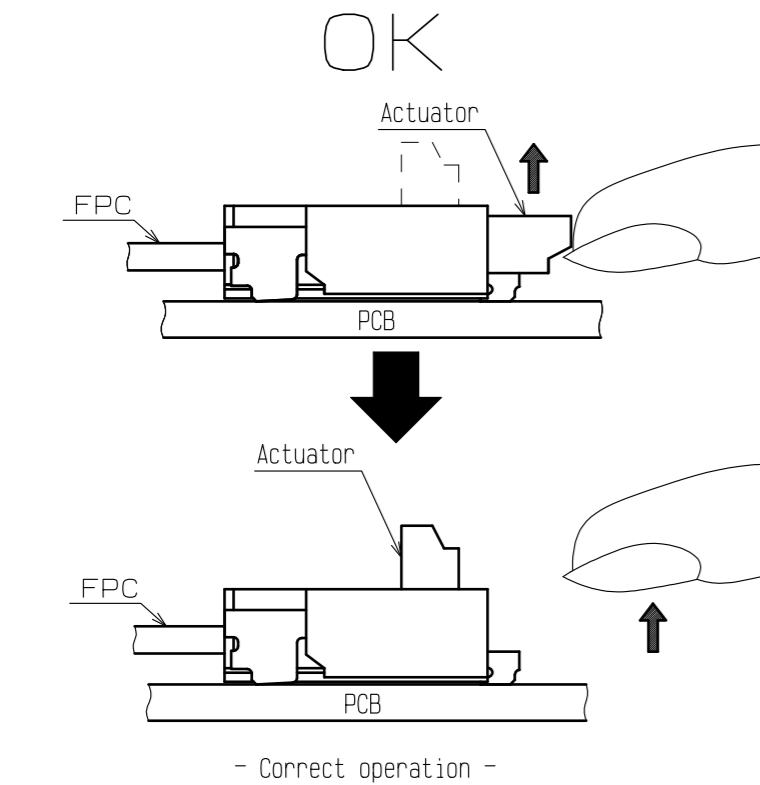

<INSTRUCTION MANUAL (3)>

HRS	DRAWING NO.	EDC-159714-50-04
	PART NO.	FH34SRJ-*S-0.5SH(50)
	CODE NO.	CL580
		4/7/8

Aug.1.2019 Copyright 2019 HIROSE ELECTRIC CO., LTD. All Rights Reserved.
In case of consideration for using Automotive equipment / device which demand high reliability, kindly contact our sales window correspondents.

[Precautions for design]

1. During FPC wiring, ensure that stress is not applied directly to the connector. Do not bend the FPC excessively near the connector during use, or it may cause contact failure or FPC breakage. Stabilizing the FPC is recommended.
2. Keep a sufficient FPC insertion space in the stage of the layout in order to avoid incorrect FPC insertion. Appropriate FPC length and component layout are recommended for assembly ease. Too short FPC length makes assembly difficult.
3. Follow the recommended PCB mounting pattern, stencil opening design and the FPC design.
4. Make adjustments with the FPC manufacturer for FPC bending performance and wire breakage.
5. Keep spaces for the actuator movement and its operation for PCB design and component layout.

[FPC routing after connection]

Depending on a FPC rounding, a load is applied to the connector, and a contact failure may occur. To prevent a failure, take the following notes into a consideration during mechanism design.

[Caution]

- Avoid applying forces to FPC in vertical or horizontal directions. In addition, avoid pulling up and down on the FPC.
- When fixing FPC after FPC cabling, avoid pulling FPC, and route the wire FPC with slack. In this regard, the stiffener is parallel to the PCB.
- Do not mount other components touching to the FPC underneath the FPC stiffener.

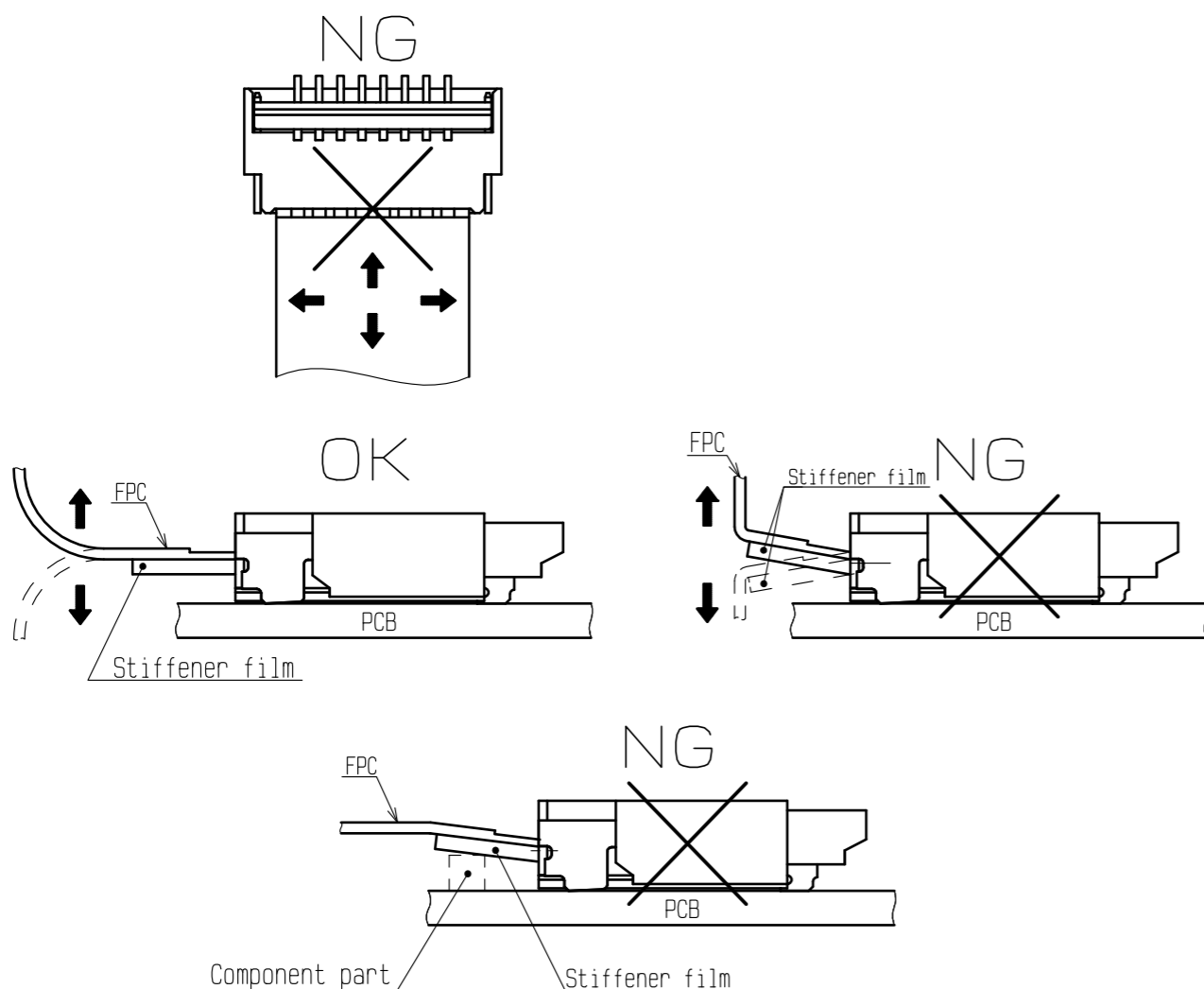

[Instructions for mounting on the PCB]

- ◆Warp of PCB
Minimize warp of the PCB as much as possible. Lead co-planarity including reinforced metal fittings is 0.1 mm or less. Too much warp of the PCB may result in a soldering failure.
- ◆Flexible board design
Please make sure to put a stiffener on the backside of the flexible board. We recommend a glass epoxy material with the thickness of 0.3mm MIN.
- ◆Load to Connector
Do not add 0.5N or greater external force when unreel or pick and place the connector etc, or it may get broken. In addition, do not insert the FPC or operate the connector before mounting.
- ◆Reflow temperature profile
Apply reflow temperature profile within the specified conditions. In individual applications, the actual temperature may vary, depending on solder paste type, volume/thickness and PCB size/thickness. Consult your solder paste and equipment manufacturer for specific recommendations.

[INSTRUCTIONS FOR PCB HANDLING AFTER MOUNTING THE CONNECTOR]

- ◆Load to PCB
· Splitting a large PCB into several pieces
· Screwing the PCB
Avoid the handling described above so that no force is exerted on the PCB during the assembly process. Otherwise, the connector may become defective.
- ◆Amount of Warp
The warp of a 100mm wide PCB should be 0.5 mm or less. The warp of PCB suffers stress on connector and the connector may become defective.

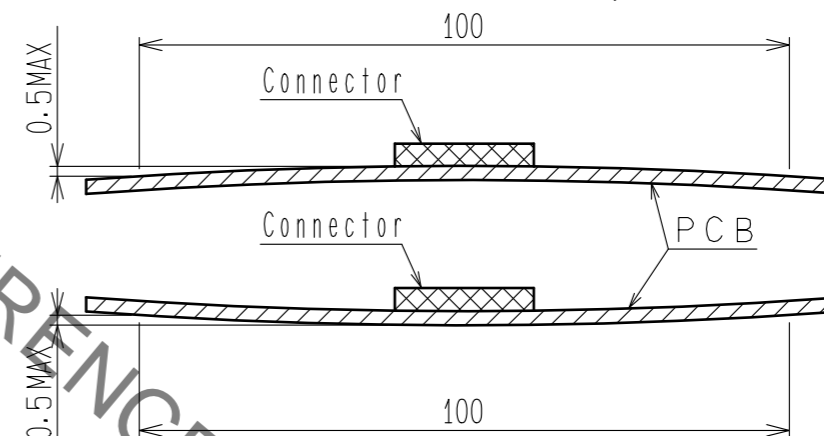

[Other instructions]

- ◆Instructions on manual soldering
Follow the instructions shown below when soldering the connector manually during repair work, etc.
 1. Do not perform manual soldering with the FPC inserted into the connector.
 2. Do not heat the connector excessively. Be very careful not to let the soldering iron contact any parts other than connector leads. Otherwise, the connector may be deformed or melt.
 3. Do not supply excessive solder (or flux).
If excessive solder (or flux) is supplied on the terminals, solder or flux may adhere to the contacts or rotating parts of the actuator, resulting in poor contact or a rotation failure of the actuator. Supplying excessive solder to the metal fittings may hinder actuator rotation, resulting in breakage of the connector.

<INSTRUCTION MANUAL (4)>

HRS	DRAWING NO.	EDC-159714-50-04
	PART NO.	FH34SRJ-*S-0.5SH(50)
	CODE NO.	CL580
		4/8

Looking for pricing, stock, or lifecycle information?

Click below to explore more details on WIN SOURCE:

- ⊖ [View FH34SRJ-22S-0.5SH\(50\) on WIN SOURCE](#)
- ⊖ [Hirose Electric Co Ltd Information](#)

Optimize Your Supply Chain with WIN SOURCE Solutions

- ✓ Global Sourcing Solution
- ✓ Obsolete Management
- ✓ Cost Control Management
- ✓ Shortage Management
- ✓ Alternative Solution
- ✓ Excess Inventory Management