



**THE DATASHEET OF
CY62167ELL-45ZXIT**



Features

- Configurable as 1 M × 16 or as 2 M × 8 SRAM
- Very high speed: 45 ns
- Wide voltage range: 4.5 V to 5.5 V
- Ultra low standby power
 - Typical standby current: 1.5 μA
 - Maximum standby current: 12 μA
- Ultra low active power
 - Typical active current: 2.2 mA at f = 1 MHz
- Easy memory expansion with \overline{CE}_1 , CE_2 , and \overline{OE} features
- Automatic power-down when deselected
- CMOS for optimum speed and power
- Offered in 48-pin TSOP I package

Functional Description

The CY62167E is a high performance CMOS static RAM organized as 1 M words by 16-bits/2 M words by 8-bits. This device features advanced circuit design to provide an ultra low active current. This is ideal for providing More Battery Life™ (MoBL®) in portable applications. The device also has an automatic power down feature that reduces power consumption when addresses are not toggling. Place the device into standby mode when deselected (CE_1 HIGH, or CE_2 LOW, or both BHE

and \overline{BLE} are HIGH). The input and output pins (I/O_0 through I/O_{15}) are placed in a high impedance state when:

- The device is deselected (\overline{CE}_1 HIGH or CE_2 LOW)
- Outputs are disabled (\overline{OE} HIGH)
- Both byte high enable and byte low enable are disabled (\overline{BHE} , \overline{BLE} HIGH) or
- A write operation is in progress (\overline{CE}_1 LOW, CE_2 HIGH, and \overline{WE} LOW)

To write to the device, take chip enables (\overline{CE}_1 LOW and CE_2 HIGH) and write enable (\overline{WE}) input LOW. If byte low enable (\overline{BLE}) is LOW, then data from I/O pins (I/O_0 through I/O_7), is written into the location specified on the address pins (A_0 through A_{19}). If byte high enable (\overline{BHE}) is LOW, then data from the I/O pins (I/O_8 through I/O_{15}) is written into the location specified on the address pins (A_0 through A_{19}).

To read from the device, take chip enables (\overline{CE}_1 LOW and CE_2 HIGH) and output enable (\overline{OE}) LOW while forcing the write enable (\overline{WE}) HIGH. If byte low enable (\overline{BLE}) is LOW, then data from the memory location specified by the address pins appears on I/O_0 to I/O_7 . If byte high enable (\overline{BHE}) is LOW, then data from memory appears on I/O_8 to I/O_{15} . See Truth Table on page 12 for a complete description of read and write modes.

The CY62167E device is suitable for interfacing with processors that have TTL I/P levels. It is not suitable for processors that require CMOS I/P levels. Please see Electrical Characteristics on page 4 for more details and suggested alternatives.

For a complete list of related documentation, click [here](#).

Logic Block Diagram

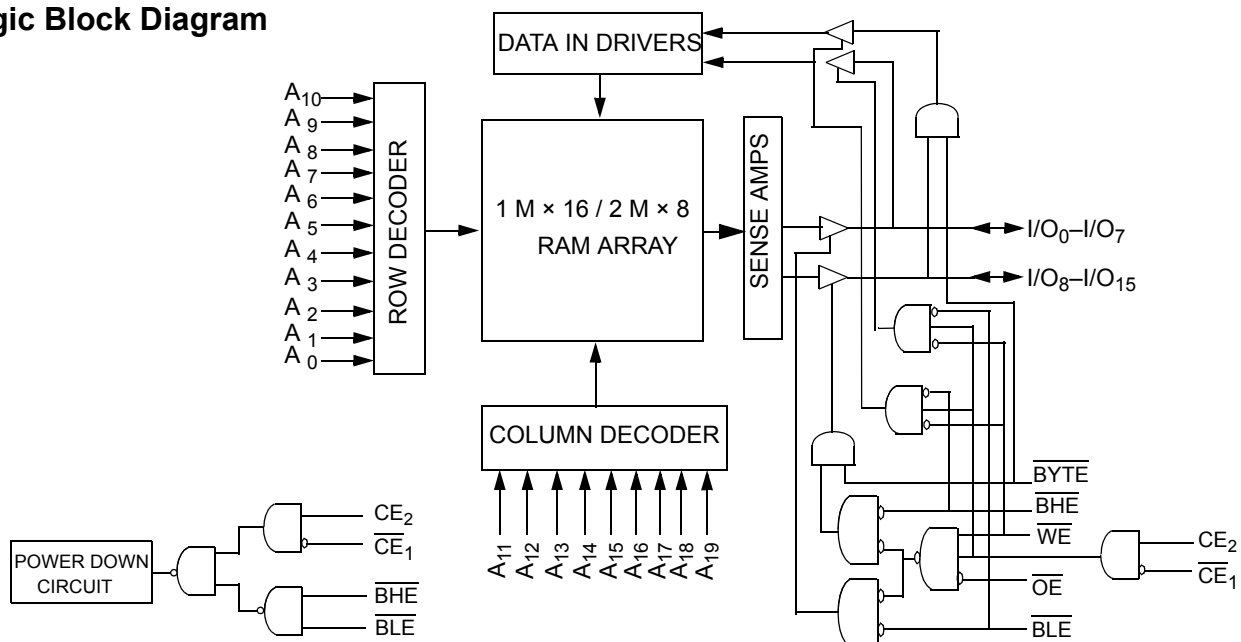

Contents

Pin Configuration	3	Ordering Information	13
Product Portfolio	3	Ordering Code Definitions	13
Maximum Ratings	4	Package Diagram	14
Operating Range	4	Acronyms	15
Electrical Characteristics	4	Document Conventions	15
Capacitance	5	Units of Measure	15
Thermal Resistance	5	Document History Page	16
AC Test Loads and Waveforms	5	Sales, Solutions, and Legal Information	18
Data Retention Characteristics	6	Worldwide Sales and Design Support	18
Data Retention Waveform	6	Products	18
Switching Characteristics	7	PSoC® Solutions	18
Switching Waveforms	8	Cypress Developer Community	18
Truth Table	12	Technical Support	18

Pin Configuration

48-pin TSOP I pinout (Top View) [1, 2]

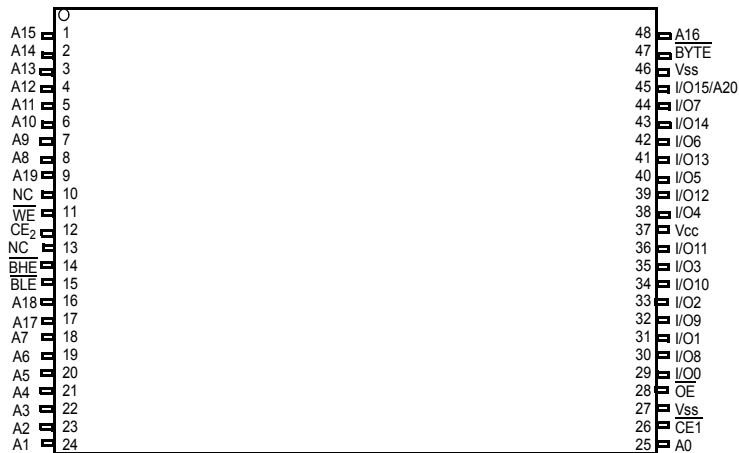

Product Portfolio

Product	V _{CC} Range (V)			Speed (ns)	Power Dissipation					
					Operating I _{CC} (mA)				Standby I _{SB2} (μA)	
	f = 1 MHz		f = f _{max}							
	Min	Typ ^[3]	Max		Typ ^[3]	Max	Typ ^[3]	Max	Typ ^[3]	Max
CY62167ELL	4.5	5.0	5.5	45	2.2	4.0	25	30	1.5	12

Notes

- NC pins are not connected on the die.
- The BYTE pin in the 48-pin TSOP I package must be tied to V_{CC} to use the device as a 1 M × 16 SRAM. The 48-TSOP I package can also be used as a 2 M × 8 SRAM by tying the BYTE signal to V_{SS}. In the 2 M × 8 configuration, pin 45 is A20, while BHE, BLE and I/O₈ to I/O₁₄ pins are not used.
- Typical values are included for reference only and are not guaranteed or tested. Typical values are measured at V_{CC} = V_{CC(typ)}, T_A = 25 °C.

Maximum Ratings

Exceeding maximum ratings may shorten the useful life of the device. User guidelines are not tested.

Storage temperature	-65 °C to +150 °C
Ambient temperature with power applied	-55 °C to +125 °C
Supply voltage to ground potential ^[4, 5]	-0.5 V to 6.0 V
DC voltage applied to outputs in high Z state ^[4, 5]	-0.5 V to 6.0 V

DC input voltage ^[4, 5]	-0.5 V to 6.0 V
Output current into outputs (LOW)	20 mA
Static discharge voltage (MIL-STD-883, method 3015)	>2001 V
Latch-up current	>200 mA

Operating Range

Device	Range	Ambient Temperature	V _{CC} ^[6]
CY62167ELL	Industrial	-40 °C to +85 °C	4.5 V to 5.5 V

Electrical Characteristics

Over the Operating Range

Parameter	Description	Test Conditions		45 ns			Unit
				Min	Typ ^[7]	Max	
V _{OH}	Output HIGH voltage	V _{CC} = 4.5 V	I _{OH} = -1.0 mA	2.4	-	-	V
		V _{CC} = 5.5 V	I _{OH} = -0.1 mA	-	-	3.4 ^[8]	
V _{OL}	Output LOW voltage	I _{OL} = 2.1 mA		-	-	0.4	V
V _{IH}	Input HIGH voltage	V _{CC} = 4.5 V to 5.5 V		2.2	-	V _{CC} + 0.5 V	V
V _{IL}	Input LOW voltage	V _{CC} = 4.5 V to 5.5 V		-0.5	-	0.7 ^[9]	V
I _{IX}	Input leakage current	GND ≤ V _I ≤ V _{CC}		-1	-	+1	μA
I _{OZ}	Output leakage current	GND ≤ V _O ≤ V _{CC} , output disabled		-1	-	+1	μA
I _{CC}	V _{CC} operating supply current	f = f _{MAX} = 1/t _{RC}	V _{CC} = V _{CC(max)} I _{OUT} = 0 mA CMOS levels	-	25	30	mA
		f = 1 MHz		-	2.2	4.0	
I _{SB2} ^[10]	Automatic power down current—CMOS inputs	$\overline{CE}_1 \geq V_{CC} - 0.2 \text{ V}$ or $CE_2 \leq 0.2 \text{ V}$, or \overline{BHE} and $\overline{BLE} \geq V_{CC} - 0.2 \text{ V}$, $V_{IN} \geq V_{CC} - 0.2 \text{ V}$ or $V_{IN} \leq 0.2 \text{ V}$, $f = 0$, V _{CC} = V _{CC(max)}		-	1.5	12	μA

Notes

- V_{IL(min)} = -2.0 V for pulse durations less than 20 ns.
- V_{IH(max)} = V_{CC} + 0.75 V for pulse durations less than 20 ns.
- Full Device AC operation is based on a 100 μs ramp time from 0 to V_{CC(min)} and 200 μs wait time after V_{CC} stabilization.
- Typical values are included for reference only and are not guaranteed or tested. Typical values are measured at V_{CC} = V_{CC(typ)}, T_A = 25 °C.
- Please note that the maximum V_{OH} limit does not exceed minimum CMOS V_{IH} of 3.5 V. If you are interfacing this SRAM with 5 V legacy processors that require a minimum V_{IH} of 3.5V, please refer to Application Note [AN6081](#) for technical details and options you may consider.
- Under DC conditions the device meets a V_{IL} of 0.8 V. However, in dynamic conditions input LOW voltage applied to the device must not be higher than 0.7 V.
- Chip enables (CE₁ and CE₂), byte enables (BHE and BLE) and BYTE need to be tied to CMOS levels to meet the I_{SB2} / I_{CCDR} spec. Other inputs can be left floating.

Capacitance

Parameter ^[11]	Description	Test Conditions	Max	Unit
C _{IN}	Input capacitance	T _A = 25 °C, f = 1 MHz, V _{CC} = V _{CC(typ)}	10	pF
C _{OUT}	Output capacitance		10	pF

Thermal Resistance

Parameter ^[11]	Description	Test Conditions	48-pin TSOP I	Unit
Θ _{JA}	Thermal resistance (junction to ambient)	Still air, soldered on a 3 × 4.5 inch, four-layer printed circuit board	54.25	°C/W
Θ _{JC}	Thermal resistance (junction to case)		12.63	°C/W

AC Test Loads and Waveforms

Figure 1. AC Test Loads and Waveforms

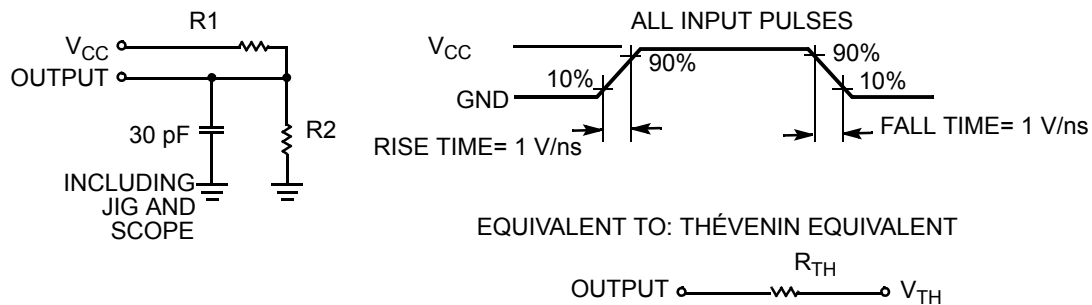

Parameters	Values	Unit
R1	1800	Ω
R2	990	Ω
R _{TH}	639	Ω
V _{TH}	1.77	V

Note

¹¹. Tested initially and after any design or process changes that may affect these parameters.

Data Retention Characteristics

Over the operating range

Parameter	Description	Conditions	Min	Typ ^[12]	Max	Unit
V_{DR}	V_{CC} for data retention	–	2.0	–	–	V
$I_{CCDR}^{[13]}$	Data retention current	$V_{CC} = V_{DR}$, $\overline{CE}_1 \geq V_{CC} - 0.2$ V or $CE_2 \leq 0.2$ V, or \overline{BHE} and $\overline{BLE} \geq V_{CC} - 0.2$ V, $V_{IN} \geq V_{CC} - 0.2$ V or $V_{IN} \leq 0.2$ V	–	–	12	μ A
$t_{CDR}^{[14]}$	Chip deselect to data retention time	–	0	–	–	ns
$t_R^{[15]}$	Operation recovery time	–	45	–	–	ns

Data Retention Waveform

Figure 2. Data Retention Waveform^[16]

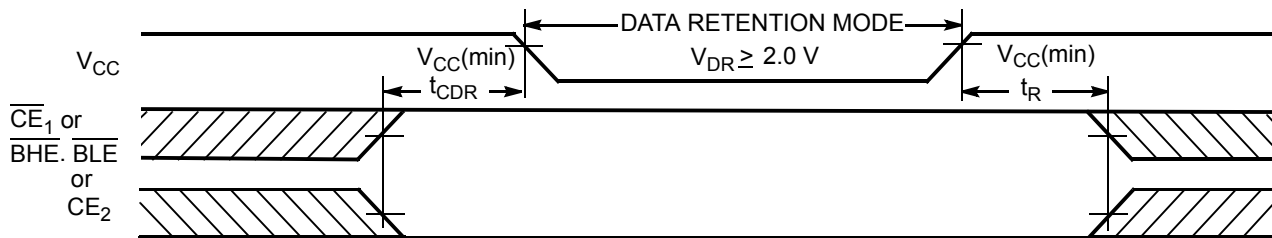

Notes

12. Typical values are included for reference only and are not guaranteed or tested. Typical values are measured at $V_{CC} = V_{CC}(typ)$, $T_A = 25$ °C.
13. Chip enables (\overline{CE}_1 and CE_2), byte enables (\overline{BHE} and \overline{BLE}) and \overline{BYTE} need to be tied to CMOS levels to meet the I_{SB2} / I_{CCDR} spec. Other inputs can be left floating.
14. Tested initially and after any design or process changes that may affect these parameters.
15. Full device operation requires linear V_{CC} ramp from V_{DR} to $V_{CC}(min) \geq 100$ μ s or stable at $V_{CC}(min) \geq 100$ μ s.
16. \overline{BHE} , \overline{BLE} is the AND of \overline{BHE} and \overline{BLE} . Deselect the chip by either disabling the chip enable signals or by disabling \overline{BHE} and \overline{BLE} .

Switching Characteristics

Over the Operating Range

Parameter ^[17, 18]	Description	45 ns		Unit
		Min	Max	
Read Cycle				
t_{RC}	Read cycle time	45	–	ns
t_{AA}	Address to data valid	–	45	ns
t_{OHA}	Data hold from address change	10	–	ns
t_{ACE}	\overline{CE}_1 LOW and CE_2 HIGH to data valid	–	45	ns
t_{DOE}	\overline{OE} LOW to data valid	–	22	ns
t_{LZOE}	\overline{OE} LOW to low Z ^[19]	5	–	ns
t_{HZOE}	\overline{OE} HIGH to high Z ^[19, 20]	–	18	ns
t_{LZCE}	\overline{CE}_1 LOW and CE_2 HIGH to low Z ^[19]	10	–	ns
t_{HZCE}	\overline{CE}_1 HIGH and CE_2 LOW to high Z ^[19, 20]	–	18	ns
t_{PU}	\overline{CE}_1 LOW and CE_2 HIGH to power-up	0	–	ns
t_{PD}	\overline{CE}_1 HIGH and CE_2 LOW to power-down	–	45	ns
t_{DBE}	$\overline{BLE}/\overline{BHE}$ LOW to data valid	–	45	ns
t_{LZBE}	$\overline{BLE}/\overline{BHE}$ LOW to low Z ^[19, 21]	5	–	ns
t_{HZBE}	$\overline{BLE}/\overline{BHE}$ HIGH to high Z ^[19, 20]	–	18	ns
Write Cycle^[22, 23]				
t_{WC}	Write cycle time	45	–	ns
t_{SCE}	\overline{CE}_1 LOW and CE_2 HIGH to write end	35	–	ns
t_{AW}	Address setup to write end	35	–	ns
t_{HA}	Address hold from write end	0	–	ns
t_{SA}	Address setup to write start	0	–	ns
t_{PWE}	\overline{WE} pulse width	35	–	ns
t_{BW}	$\overline{BLE}/\overline{BHE}$ LOW to write end	35	–	ns
t_{SD}	Data setup to write end	25	–	ns
t_{HD}	Data hold from write end	0	–	ns
t_{HZWE}	\overline{WE} LOW to high Z ^[19, 20]	–	18	ns
t_{LZWE}	\overline{WE} HIGH to low Z ^[19]	10	–	ns

Notes

17. Test conditions for all parameters other than tristate parameters assume signal transition time of 1 V/ns, timing reference levels of $V_{CC}(typ)/2$, input pulse levels of 0 to $V_{CC}(typ)$, and output loading of the specified I_{OL}/I_{OH} as shown in [Figure 1 on page 5](#).
18. In an earlier revision of this device, under a specific application condition, READ and WRITE operations were limited to switching of the byte enable and/or chip enable signals as described in the Application Notes [AN13842](#) and [AN66311](#). However, the issue has been fixed and in production now, and hence, these Application Notes are no longer applicable. They are available for download on our website as they contain information on the date code of the parts, beyond which the fix has been in production.
19. At any temperature and voltage condition, t_{HZCE} is less than t_{LZCE} , t_{HZBE} is less than t_{LZBE} , t_{HZOE} is less than t_{LZOE} , and t_{HZWE} is less than t_{LZWE} for any device.
20. t_{HZOE} , t_{HZCE} , t_{HZBE} , and t_{HZWE} transitions are measured when the outputs enter a high impedance state.
21. If both byte enables are toggled together, this value is 10 ns.
22. The internal write time of the memory is defined by the overlap of \overline{WE} , $\overline{CE}_1 = V_{IL}$, \overline{BHE} or \overline{BLE} or both = V_{IL} , and $CE_2 = V_{IH}$. All signals must be active to initiate a write and any of these signals can terminate a write by going inactive. The data input setup and hold timing should be referenced to the edge of the signal that terminates the write.
23. The minimum write cycle time for Write Cycle No. 3 (\overline{WE} controlled, \overline{OE} LOW) should be equal to the sum of t_{SD} and t_{HZWE} .

Switching Waveforms

Figure 3. Read Cycle No. 1 (Address Transition Controlled) [24, 25]

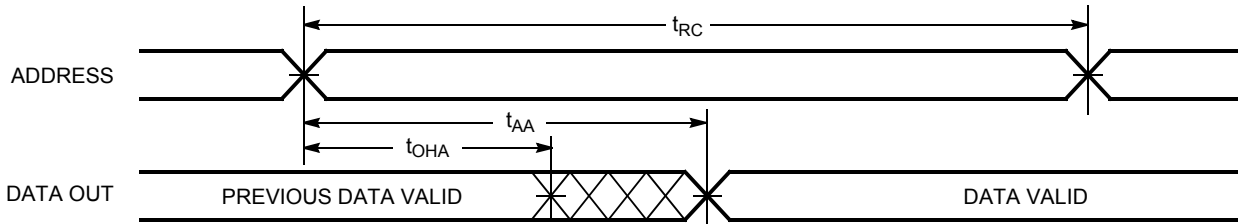
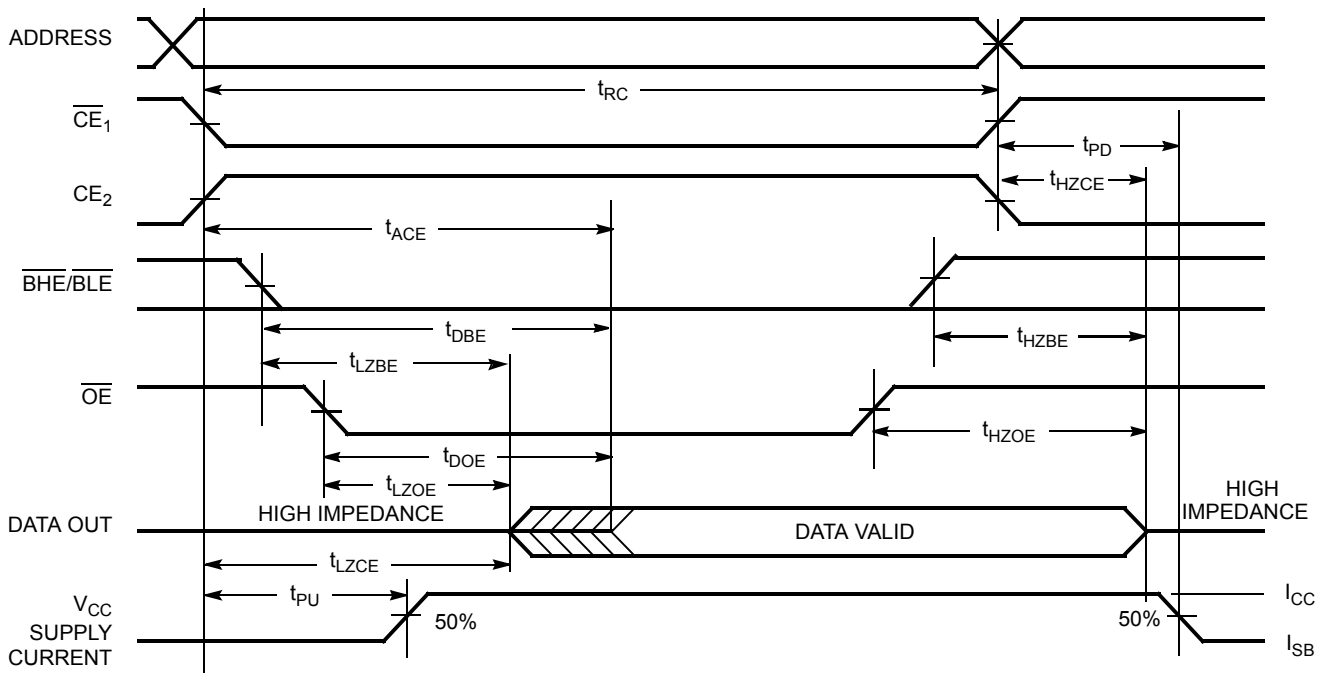

Figure 4. Read Cycle No. 2 (\overline{OE} Controlled) [25, 26]



Notes

- 24. The device is continuously selected. \overline{OE} , \overline{CE}_1 = V_{IL} , \overline{BHE} , \overline{BLE} or both = V_{IL} , and CE_2 = V_{IH} .
- 25. \overline{WE} is HIGH for read cycle.
- 26. Address valid before or similar to \overline{CE}_1 , \overline{BHE} , \overline{BLE} transition LOW and CE_2 transition HIGH.

Switching Waveforms (continued)

Figure 5. Write Cycle No. 1 (\overline{WE} Controlled) [27, 28, 29]

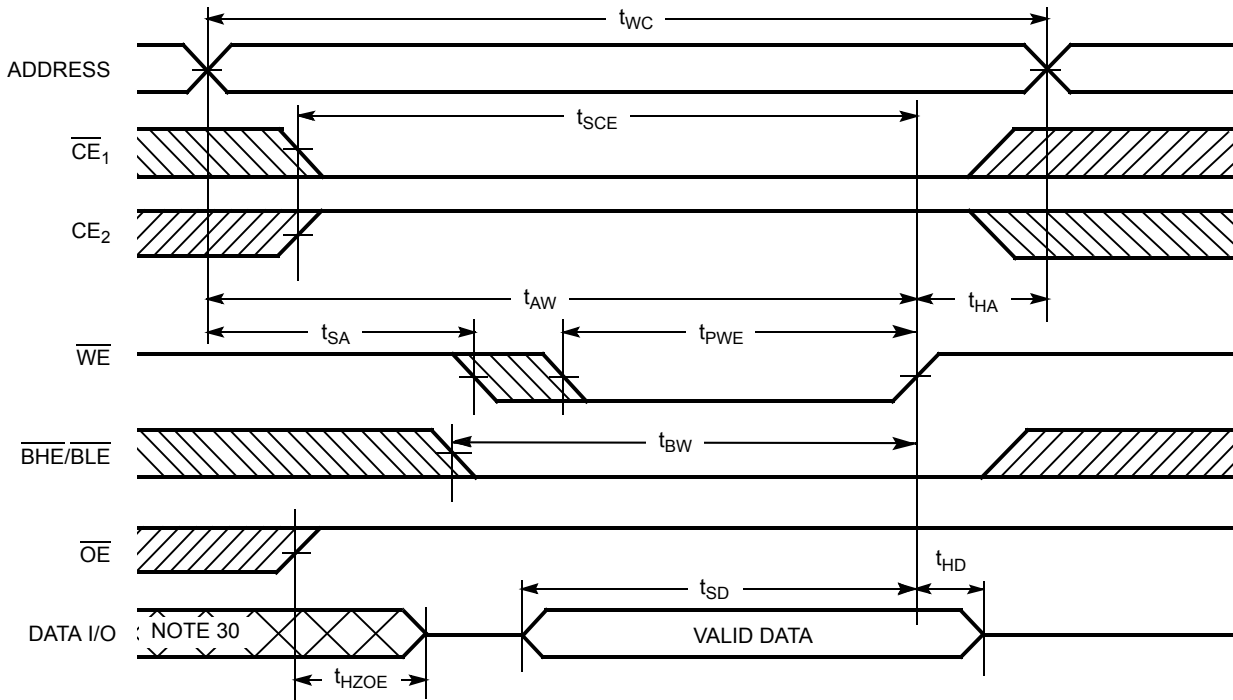

Notes

27. The internal write time of the memory is defined by the overlap of \overline{WE} , $\overline{CE}_1 = V_{IL}$, \overline{BHE} or \overline{BLE} or both = V_{IL} , and $CE_2 = V_{IH}$. All signals must be active to initiate a write and any of these signals can terminate a write by going inactive. The data input setup and hold timing should be referenced to the edge of the signal that terminates the write.

28. Data I/O is high impedance if $\overline{OE} = V_{IH}$.

29. If \overline{CE}_1 goes HIGH and CE_2 goes LOW simultaneously with $\overline{WE} = V_{IH}$, the output remains in a high impedance state.

30. During this period the I/Os are in output state and input signals must not be applied.

Switching Waveforms (continued)

Figure 6. Write Cycle No. 2 (\overline{CE}_1 or CE_2 Controlled).^[31, 32, 33]

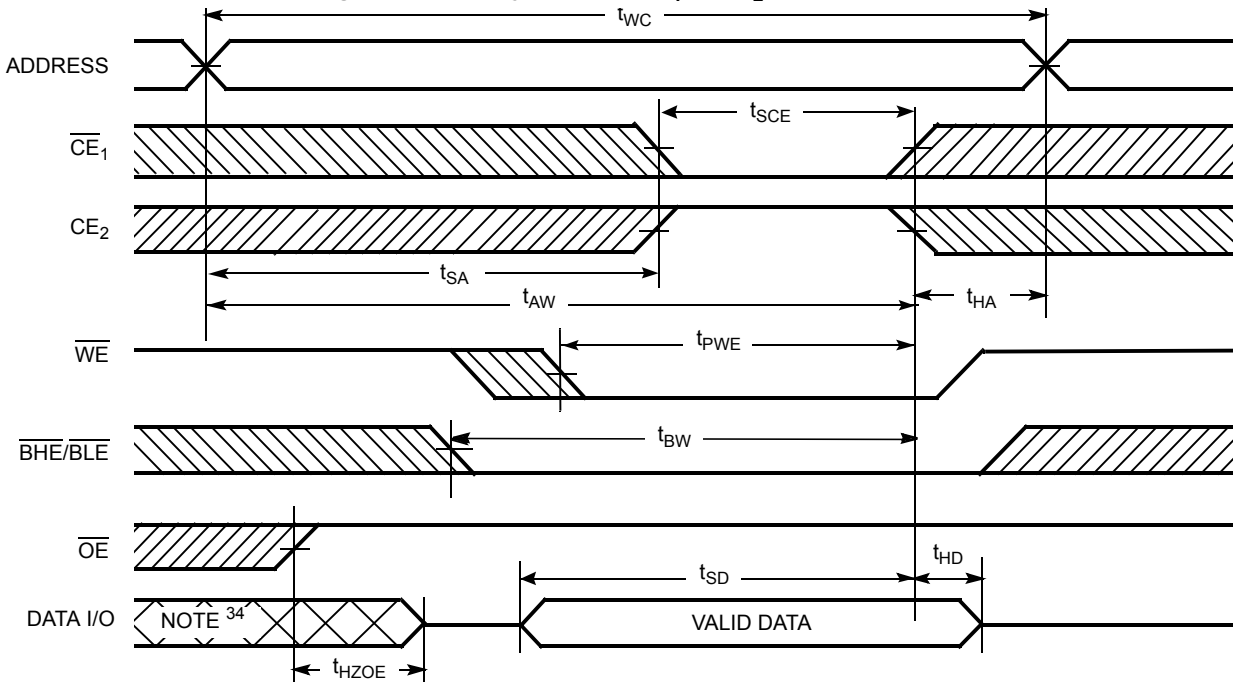
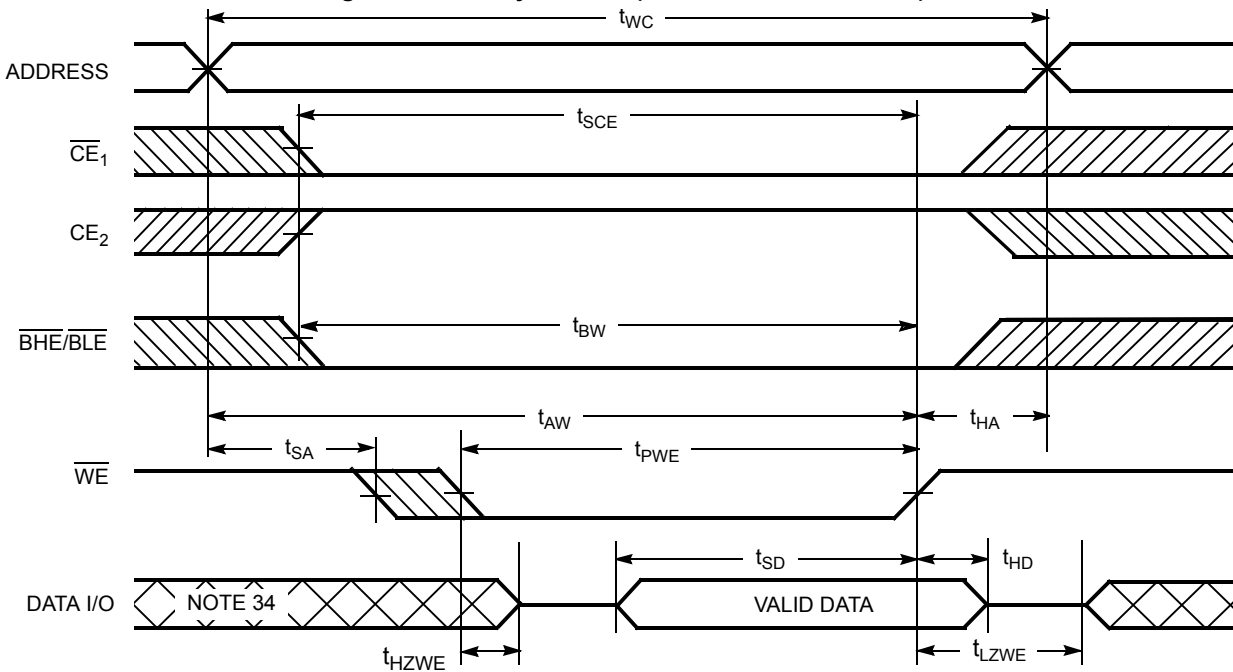

Figure 7. Write Cycle No. 3 (\overline{WE} Controlled, \overline{OE} LOW)^[33, 35]



31. The internal write time of the memory is defined by the overlap of \overline{WE} , $CE_1 = V_{IL}$, BHE or BLE or both = V_{IL} , and $CE_2 = V_{IH}$. All signals must be active to initiate a write and any of these signals can terminate a write by going inactive. The data input setup and hold timing should be referenced to the edge of the signal that terminates the write.

32. Data I/O is high impedance if $\overline{OE} = V_{IH}$.

33. If \overline{CE}_1 goes HIGH and CE_2 goes LOW simultaneously with $\overline{WE} = V_{IH}$, the output remains in a high impedance state.

34. During this period the I/Os are in output state and input signals must not be applied.

35. The minimum write cycle pulse width should be equal to the sum of t_{SD} and t_{HZWE} .

Switching Waveforms (continued)

Figure 8. Write Cycle No. 4 ($\overline{\text{BHE/BLE}}$ controlled, $\overline{\text{OE}}$ LOW)^[36]

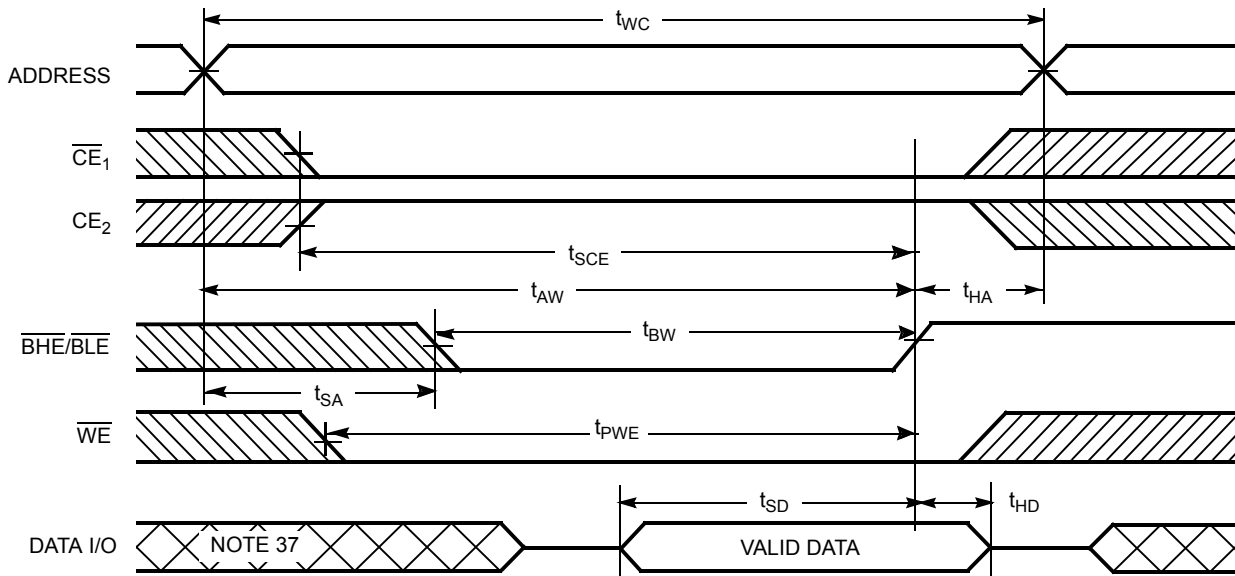

Notes

- 36. If $\overline{\text{CE}}_1$ goes HIGH and CE_2 goes LOW simultaneously with $\overline{\text{WE}} = V_{IH}$, the output remains in a high impedance state.
- 37. During this period the I/Os are in output state and input signals must not be applied.

Truth Table

\overline{CE}_1	CE_2	\overline{WE}	\overline{OE}	\overline{BHE}	\overline{BLE}	Inputs Outputs	Mode	Power
H	X ^[38]	X	X	X	X	High Z	Deselect/power-down	Standby (I_{SB})
X ^[38]	L	X	X	X	X	High Z	Deselect/power-down	Standby (I_{SB})
X ^[38]	X ^[38]	X	X	H	H	High Z	Deselect/power-down	Standby (I_{SB})
L	H	H	L	L	L	Data out (I/O_0 – I/O_{15})	Read	Active (I_{CC})
L	H	H	L	H	L	Data out (I/O_0 – I/O_7); High Z (I/O_8 – I/O_{15})	Read	Active (I_{CC})
L	H	H	L	L	H	High Z (I/O_0 – I/O_7); Data out (I/O_8 – I/O_{15})	Read	Active (I_{CC})
L	H	H	H	L	H	High Z	Output disabled	Active (I_{CC})
L	H	H	H	H	L	High Z	Output disabled	Active (I_{CC})
L	H	H	H	L	L	High Z	Output disabled	Active (I_{CC})
L	H	L	X	L	L	Data in (I/O_0 – I/O_{15})	Write	Active (I_{CC})
L	H	L	X	H	L	Data in (I/O_0 – I/O_7); High Z (I/O_8 – I/O_{15})	Write	Active (I_{CC})
L	H	L	X	L	H	High Z (I/O_0 – I/O_7); Data in (I/O_8 – I/O_{15})	Write	Active (I_{CC})

Note

38. The 'X' (Do not care) state for the chip enables in the truth table refers to the logic state (either HIGH or LOW). Intermediate voltage levels on these pins is not permitted.

Ordering Information

The below table lists the CY62167ELL key package features and ordering codes. The table contains only the parts that are currently available. If you do not see what you are looking for, contact your local sales representative. For more information, visit the Cypress website at www.cypress.com and refer to the product summary page at <http://www.cypress.com/products>.

Speed (ns)	Ordering Code	Package Diagram	Package Type	Operating Range
45	CY62167ELL-45ZXI	51-85183	48-pin TSOP I (Pb-free)	Industrial

Ordering Code Definitions

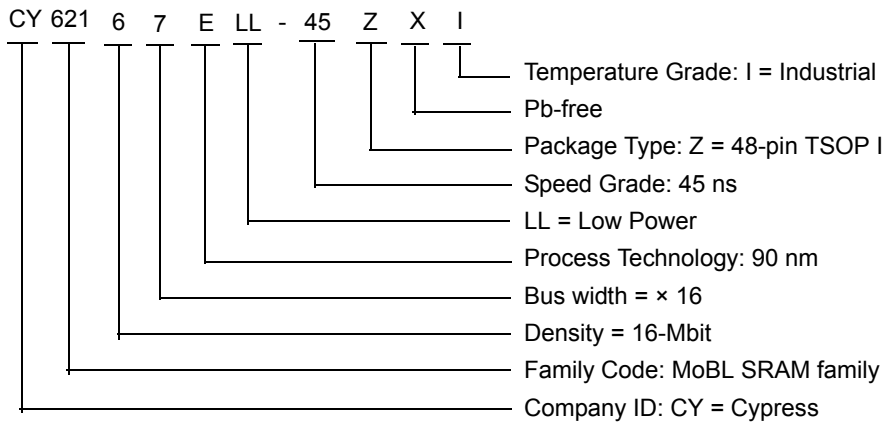

Package Diagram

Figure 9. 48-pin TSOP I (12 × 18.4 × 1.0 mm) Z48A Package Outline, 51-85183

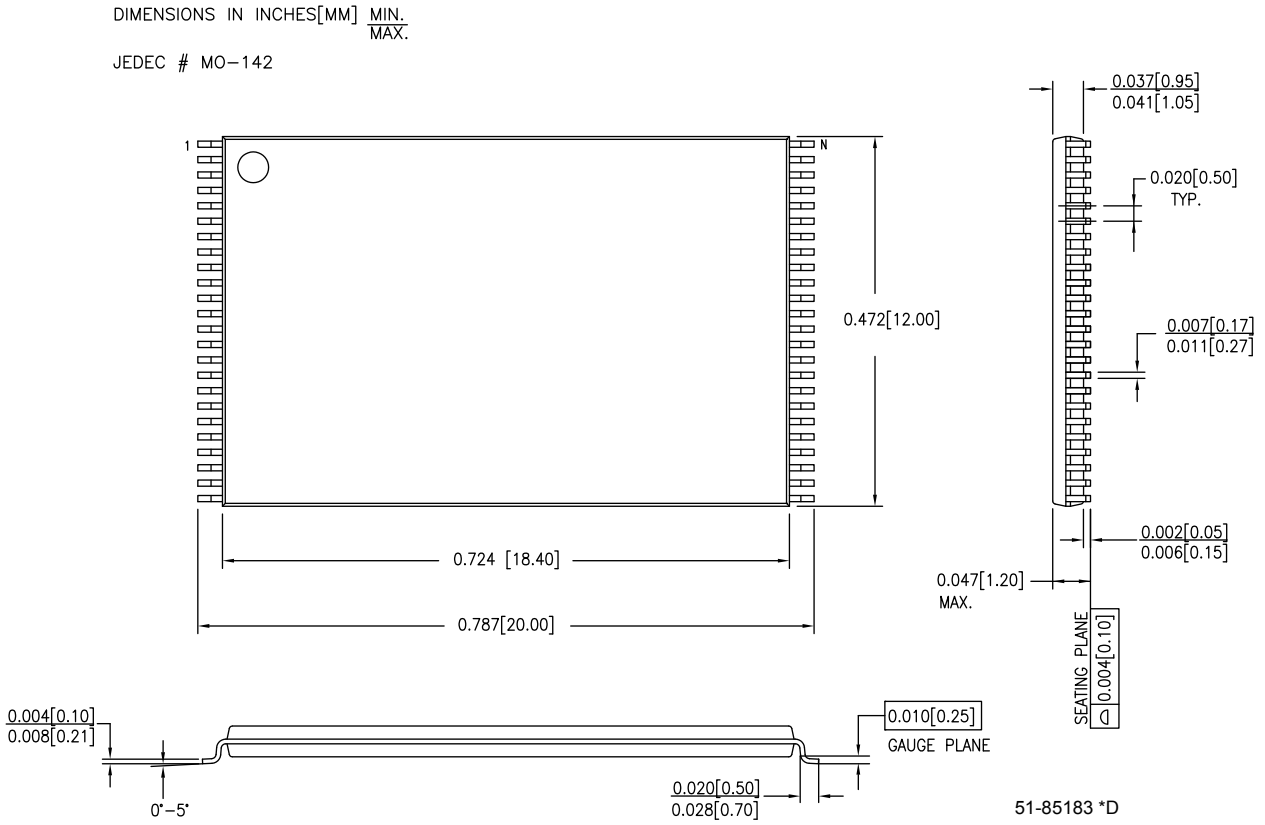

Acronyms

Acronym	Description
BHE	Byte High Enable
BLE	Byte Low Enable
CMOS	Complementary Metal Oxide Semiconductor
CE	Chip Enable
I/O	Input/Output
OE	Output Enable
SRAM	Static Random Access Memory
TSOP	Thin Small Outline Package
WE	Write Enable

Document Conventions

Units of Measure

Symbol	Unit of Measure
°C	degree Celsius
MHz	megahertz
μA	microampere
mA	milliampere
mm	millimeter
ns	nanosecond
Ω	ohm
%	percent
pF	picofarad
V	volt
W	watt

Document History Page

Document Title: CY62167E MoBL [®] , 16-Mbit (1 M × 16 / 2 M × 8) Static RAM Document Number: 001-15607				
Rev.	ECN No.	Issue Date	Orig. of Change	Description of Change
**	1103145	See ECN	VKN	New data sheet.
*A	1138903	See ECN	VKN	<p>Changed status from Preliminary to Final.</p> <p>Updated Electrical Characteristics:</p> <p>Added Note 9 and referred the same note in maximum value of V_{IL} parameter.</p> <p>Changed $I_{CC(max)}$ spec from 2.8 mA to 4.0 mA for $f = 1$ MHz.</p> <p>Changed $I_{CC(typ)}$ spec from 22 mA to 25 mA for $f = f_{max}$.</p> <p>Changed $I_{CC(max)}$ spec from 25 mA to 30 mA for $f = f_{max}$.</p> <p>Updated Data Retention Characteristics:</p> <p>Changed maximum value of I_{CCDR} parameter from 10 μA to 12 μA.</p> <p>Updated Switching Characteristics:</p> <p>Added Note 18 and referred the same note in "Parameter" column.</p>
*B	2934385	06/03/10	VKN	<p>Updated Electrical Characteristics:</p> <p>Updated details in "Test Conditions" column of I_{SB2} parameter (Included \overline{BHE}, BLE to reflect byte power down feature).</p> <p>Updated Data Retention Characteristics:</p> <p>Updated details in "Test Conditions" column of I_{CCDR} parameter (Included BHE, BLE to reflect byte power down feature).</p> <p>Updated Truth Table:</p> <p>Added Note 38 and referred the same note in X in \overline{CE}_1 and CE_2 columns.</p> <p>Updated Package Diagram.</p> <p>Updated to new template.</p>
*C	3279426	06/10/2011	RAME	<p>Removed the Note "For best practice recommendations, refer to the Cypress application note AN1064, SRAM System Guidelines." in page 1 and its reference in Functional Description.</p> <p>Updated Switching Characteristics (changed the Min value of t_{LZBE} parameter).</p> <p>Updated to new template.</p>
*D	4024137	06/10/2013	MEMJ	<p>Updated Functional Description.</p> <p>Updated Electrical Characteristics:</p> <p>Added one more Test Condition "$V_{CC} = 5.5$ V, $I_{OH} = -0.1$ mA" for V_{OH} parameter and added maximum value corresponding to that Test Condition.</p> <p>Added Note 8 and referred the same note in maximum value for V_{OH} parameter corresponding to Test Condition "$V_{CC} = 5.5$ V, $I_{OH} = -0.1$ mA".</p> <p>Updated Package Diagram:</p> <p>spec 51-85183 – Changed revision from *B to *C.</p>
*E	4101995	08/22/2013	VINI	<p>Updated Switching Characteristics:</p> <p>Updated Note 18.</p> <p>Updated to new template.</p>
*F	4578447	01/16/2015	VINI	<p>Updated Functional Description:</p> <p>Added "For a complete list of related documentation, click here." at the end.</p> <p>Updated Switching Characteristics:</p> <p>Added Note 23 and referred the same note in "Write Cycle".</p> <p>Updated Switching Waveforms:</p> <p>Added Note 35 and referred the same note in Figure 7.</p> <p>Updated Package Diagram:</p> <p>spec 51-85183 – Changed revision from *C to *D.</p> <p>Updated to new template.</p>

Document History Page *(continued)*

Document Title: CY62167E MoBL [®] , 16-Mbit (1 M × 16 / 2 M × 8) Static RAM Document Number: 001-15607				
Rev.	ECN No.	Issue Date	Orig. of Change	Description of Change
*G	4841338	07/20/2015	VINI	<p>Updated Maximum Ratings: Referred Notes 4, 5 in "Supply Voltage to Ground Potential".</p> <p>Updated Thermal Resistance: Replaced "two-layer" with "four-layer" in "Test Conditions" column. Changed value of Θ_{JA} parameter from 60 °C/W to 54.25 °C/W corresponding to 48-pin TSOP I package. Changed value of Θ_{JC} parameter from 4.3 °C/W to 12.63 °C/W corresponding to 48-pin TSOP I package.</p> <p>Updated AC Test Loads and Waveforms: Updated Figure 1: Replaced "V" with "V_{TH}" in part c. Completing Sunset Review.</p>

Sales, Solutions, and Legal Information

Worldwide Sales and Design Support

Cypress maintains a worldwide network of offices, solution centers, manufacturer's representatives, and distributors. To find the office closest to you, visit us at [Cypress Locations](#).

Products

Automotive	cypress.com/go/automotive
Clocks & Buffers	cypress.com/go/clocks
Interface	cypress.com/go/interface
Lighting & Power Control	cypress.com/go/powerpsoc
Memory	cypress.com/go/memory
PSoC	cypress.com/go/psoc
Touch Sensing	cypress.com/go/touch
USB Controllers	cypress.com/go/USB
Wireless/RF	cypress.com/go/wireless

PSoC[®] Solutions

psoc.cypress.com/solutions
PSoC 1 | PSoC 3 | PSoC 4 | PSoC 5LP

Cypress Developer Community

[Community](#) | [Forums](#) | [Blogs](#) | [Video](#) | [Training](#)

Technical Support

cypress.com/go/support

© Cypress Semiconductor Corporation, 2007-2015. The information contained herein is subject to change without notice. Cypress Semiconductor Corporation assumes no responsibility for the use of any circuitry other than circuitry embodied in a Cypress product. Nor does it convey or imply any license under patent or other rights. Cypress products are not warranted nor intended to be used for medical, life support, life saving, critical control or safety applications, unless pursuant to an express written agreement with Cypress. Furthermore, Cypress does not authorize its products for use as critical components in life-support systems where a malfunction or failure may reasonably be expected to result in significant injury to the user. The inclusion of Cypress products in life-support systems application implies that the manufacturer assumes all risk of such use and in doing so indemnifies Cypress against all charges.



Any Source Code (software and/or firmware) is owned by Cypress Semiconductor Corporation (Cypress) and is protected by and subject to worldwide patent protection (United States and foreign), United States copyright laws and international treaty provisions. Cypress hereby grants to licensee a personal, non-exclusive, non-transferable license to copy, use, modify, create derivative works of, and compile the Cypress Source Code and derivative works for the sole purpose of creating custom software and or firmware in support of licensee product to be used only in conjunction with a Cypress integrated circuit as specified in the applicable agreement. Any reproduction, modification, translation, compilation, or representation of this Source Code except as specified above is prohibited without the express written permission of Cypress.

Disclaimer: CYPRESS MAKES NO WARRANTY OF ANY KIND, EXPRESS OR IMPLIED, WITH REGARD TO THIS MATERIAL, INCLUDING, BUT NOT LIMITED TO, THE IMPLIED WARRANTIES OF MERCHANTABILITY AND FITNESS FOR A PARTICULAR PURPOSE. Cypress reserves the right to make changes without further notice to the materials described herein. Cypress does not assume any liability arising out of the application or use of any product or circuit described herein. Cypress does not authorize its products for use as critical components in life-support systems where a malfunction or failure may reasonably be expected to result in significant injury to the user. The inclusion of Cypress' product in a life-support systems application implies that the manufacturer assumes all risk of such use and in doing so indemnifies Cypress against all charges.

Use may be limited by and subject to the applicable Cypress software license agreement.

Looking for pricing, stock, or lifecycle information?

Click below to explore more details on WIN SOURCE:

-  [View CY62167ELL-45ZXIT on WIN SOURCE](#)
-  [Cypress Semiconductor Corp Information](#)

Optimize Your Supply Chain with WIN SOURCE Solutions

-  Global Sourcing Solution
-  Obsolete Management
-  Cost Control Management
-  Shortage Management
-  Alternative Solution
-  Excess Inventory Management