



**THE DATASHEET OF
MAX9157EHJ+T**



MAXIM

Quad Bus LVDS Transceiver

MAX9157

General Description

The MAX9157 is a quad bus LVDS (BLVDS) transceiver for heavily loaded, half-duplex multipoint buses. Small 32-pin QFN and TQFP packages and flow-through pinouts allow the transceiver to be placed near the connector for the shortest possible stub length. The MAX9157 drives LVDS levels into a 27Ω load (double terminated, heavily loaded LVDS bus) at up to 200Mbps. An input fail-safe circuit ensures the receiver output is high when the differential inputs are open, or undriven and shorted, or undriven and terminated. The MAX9157 differential inputs feature 52mV hysteresis for greater immunity to bus noise and reflections. The MAX9157 operates from a single 3.3V supply, consuming 80.9mA supply current with drivers enabled, and 22.7mA with drivers disabled.

The MAX9157's high-impedance I/Os (except for receiver outputs) when $V_{CC} = 0$ or open, combined with glitch-free power-up and power-down, allow hot swapping of cards in multicard bus systems; 7.2pF (max) BLVDS I/O capacitances minimize bus loading.

The MAX9157 is offered in 5mm x 5mm 32-pin QFN and TQFP packages. The MAX9157 is fully specified for the -40°C to $+85^{\circ}\text{C}$ extended temperature range. Refer to the MAX9129 data sheet for a quad BLVDS driver, ideal for dual multipoint full-duplex buses.

Applications

Add/Drop Muxes	Cellular Phone Base Stations
Digital Cross-Connects	DSLAMs
Network Switches/Routers	Multipoint Buses

Features

- ◆ 32-TQFP and Space-Saving 32-QFN Packages
- ◆ 52mV LVDS Input Hysteresis
- ◆ 1ns (min) Transition Time (0% to 100%) Minimizes Reflections
- ◆ Guaranteed 7.2pF (max) Bus Load Capacitance
- ◆ Glitch-Free Power-Up and Power-Down
- ◆ Hot-Swappable, High-Impedance I/O with $V_{CC} = 0$ or Open
- ◆ Guaranteed 200Mbps Driver Data Rate
- ◆ Fail-Safe Circuit
- ◆ Flow-Through Pinout

Ordering Information

PART	TEMP RANGE	PIN-PACKAGE
MAX9157EGJ	-40°C to $+85^{\circ}\text{C}$	32 QFN (5mm x 5mm)
MAX9157EHJ	-40°C to $+85^{\circ}\text{C}$	32 TQFP (5mm x 5mm)

Pin Configurations appear at end of data sheet.

Functional Diagram appears at end of data sheet.

Typical Operating Circuit

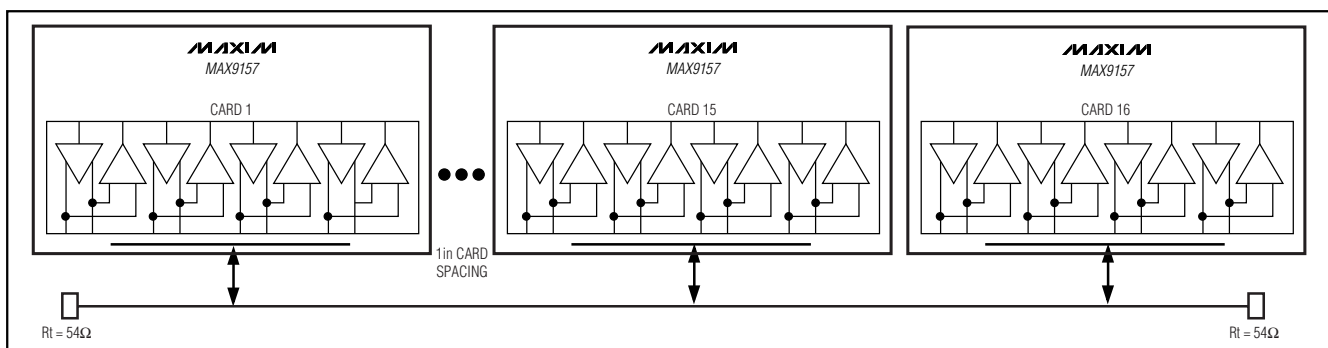

Quad Bus LVDS Transceiver

ABSOLUTE MAXIMUM RATINGS

V_{CC}, AV_{CC} to GND-0.3V to +4.0V
 DO₊/RIN₊, DO₋/RIN₋, to GND-0.3V to +4.0V
 DIN₋, DE₋, RE₋ to GND-0.3V to +4.0V
 RO₋ to GND-0.3V to (V_{CC} + 0.3V)
 AGND to GND-0.3V to +0.3V
 Short-Circuit Duration (DO₊/RIN₊, DO₋/RIN₋)Continuous
 Continuous Power Dissipation (T_A = +70°C)
 MAX9157EGJ (derate 21.2mW/°C above +70°C)1702mW

MAX9157EHJ (derate 11.1mW/°C above +70°C)889mW
 Storage Temperature Range-65°C to +150°C
 Maximum Junction Temperature+150°C
 Operating Temperature Range-40°C to +85°C
 ESD Protection
 Human Body Model (DO₊/RIN₊, DO₋/RIN₋)±4kV
 Lead Temperature (soldering, 10s)+300°C

Stresses beyond those listed under "Absolute Maximum Ratings" may cause permanent damage to the device. These are stress ratings only, and functional operation of the device at these or any other conditions beyond those indicated in the operational sections of the specifications is not implied. Exposure to absolute maximum rating conditions for extended periods may affect device reliability.

DC ELECTRICAL CHARACTERISTICS

(V_{CC} = 3.0V to 3.6V, R_L = 27Ω ±1%, differential input voltage |V_{ID}| = 0.1V to V_{CC}, input common-mode voltage V_{CM} = 0.05V to 2.4V, input voltage range = 0 to V_{CC}, DE₋ = high, RE₋ = low, T_A = -40°C to +85°C, unless otherwise noted. Typical values are at V_{CC} = 3.3V, |V_{ID}| = 0.2V, V_{CM} = 1.2V, and T_A = +25°C.) (Notes 1 and 2)

PARAMETER	SYMBOL	CONDITIONS		MIN	TYP	MAX	UNITS
BLVDS (DO₊/RIN₊, DO₋/RIN₋)							
Differential Input High Threshold	V _{TH}	DE ₋ = low			26	100	mV
Differential Input Low Threshold	V _{TL}	DE ₋ = low		-100	-26		mV
Threshold Hysteresis (Note 3)	V _{HYST}	DE ₋ = low	T _A = +25°C, V _{CC} = 3.3V, V _{CM} = 1.2V	12	26	43	mV
			Full operating range	9	26	78	
Input Current	I _{IN+} , I _{IN-}	0.1V ≤ V _{ID} ≤ 0.6V, DE ₋ = low		-15	±1.8	15	μA
		0.6V < V _{ID} ≤ 1.2V, DE ₋ = low		-20	±2.5	20	μA
Input Resistance	R _{IN1}	V _{CC} = 3.6V, 0 or open, Figure 1		53			kΩ
	R _{IN2}	V _{CC} = 3.6V, 0 or open, Figure 1		148			kΩ
Power-Off Input Current	I _{INO+} , I _{INO-}	0.1V ≤ V _{ID} ≤ 0.6V, V _{CC} = 0 or open		-15	±0.9	15	μA
		0.6V < V _{ID} ≤ 1.2V, V _{CC} = 0 or open		-20	±1.8	20	μA
Differential Output Voltage	V _{OD}	Figure 2		250	405	460	mV
Change in Magnitude of V _{OD} for Complementary Output States	ΔV _{OD}	Figure 2			1	25	mV
Offset Voltage	V _{OS}	Figure 2		1.185	1.302	1.435	V
Change in Magnitude of V _{OS} for Complementary Output States	ΔV _{OS}	Figure 2			3.3	25	mV
Output High Voltage	V _{OH}	Figure 2			1.505	1.6	V
Output Low Voltage	V _{OL}	Figure 2		0.9	1.099		V
Output Short-Circuit Current	I _{OS}	DIN ₋ = high, DO ₊ /RIN ₊ = 0 or V _{CC} , DO ₋ /RIN ₋ = 0 or V _{CC}		-30	-14.8	30	mA
		DIN ₋ = low, DO ₋ /RIN ₋ = 0 or V _{CC} , DO ₊ /RIN ₊ = 0 or V _{CC}		-30	-14.8	30	

Quad Bus LVDS Transceiver

MAX9157

DC ELECTRICAL CHARACTERISTICS (continued)

($V_{CC} = 3.0V$ to $3.6V$, $R_L = 27\Omega \pm 1\%$, differential input voltage $|V_{ID}| = 0.1V$ to V_{CC} , input common-mode voltage $V_{CM} = 0.05V$ to $2.4V$, input voltage range = 0 to V_{CC} , $DE_- = \text{high}$, $\overline{RE_-} = \text{low}$, $T_A = -40^\circ C$ to $+85^\circ C$, unless otherwise noted. Typical values are at $V_{CC} = 3.3V$, $|V_{ID}| = 0.2V$, $V_{CM} = 1.2V$, and $T_A = +25^\circ C$.) (Notes 1 and 2)

PARAMETER	SYMBOL	CONDITIONS	MIN	TYP	MAX	UNITS	
Differential Output Short-Circuit Current (Note 3)	I_{OSD}	$DIN_- = \text{high or low}$, $V_{OD} = 0$		14.8	30	mA	
Capacitance at Bus Pins (Note 3)	C_{OUTPUT}	Capacitance from DO_+/RIN_+ or DO_-/RIN_- to GND, $V_{CC} = 3.6V$ or 0			7.2	pF	
LVCMOS/LVTTL OUTPUTS (RO₋)							
Output High Voltage	V_{OH}	$I_{OH} = -4.0mA$, $DE_- = \text{low}$	Open, undriven short, or undriven 27Ω parallel termination		$V_{CC} - 0.3$	$V_{CC} - 0.172$	V
			$V_{ID} = 100mV$		$V_{CC} - 0.3$	$V_{CC} - 0.172$	
Output Low Voltage	V_{OL}	$I_{OL} = 4.0mA$, $V_{ID} = -100mV$, $DE_- = \text{low}$		0.179	0.25	V	
Dynamic Output Current	I_{OD}	$V_{ID} = 100mV$, $V_{RO_-} = V_{CC} - 1.0V$, $DE_- = \text{low}$	-15	-22.7		mA	
		$V_{ID} = -100mV$, $V_{RO_-} = 1.0V$, $DE_- = \text{low}$	12	19.9		mA	
Output Short-Circuit Current (Note 4)	I_{OS}	$V_{ID} = 100mV$, $V_{RO_-} = 0$, $DE_- = \text{low}$		-52	-130	mA	
Output High-Impedance Current	I_{OZ}	$RE_- = \text{high}$, $V_{RO} = 0$ or V_{CC}	-10	0.1	+10	μA	
Capacitance at Receiver Output (Note 3)	C_{OUTPUT}	Capacitance from RO_- to GND, $V_{CC} = 3.6V$ or 0			4.5	pF	
LVCMOS/LVTTL INPUTS (DIN, DE, RE)							
Input High Voltage	V_{IH}		2.0	1.825	V_{CC}	V	
Input Low Voltage	V_{IL}		GND	1.315	0.8	V	
Input Current	I_{IN}	V_{DE_-} , V_{RE_-} , $V_{DIN_-} = \text{high or low}$	-20	± 9.2	20	μA	
Power-Off Input Current	I_{INO}	V_{DE_-} , V_{RE_-} , $V_{DIN_-} = 3.6V$ or 0 , $V_{CC} = 0$ or open	-20	± 2.4	20	μA	
SUPPLY							
Supply Current Drivers and Receivers Enabled	I_{CC}	$DE_- = \text{high}$, $RE_- = \text{low}$, $R_L = 27\Omega$		80.9	95	mA	
Supply Current Drivers Enabled and Receivers Disabled	I_{CCD}	$DE_- = \text{high}$, $RE_- = \text{high}$, $R_L = 27\Omega$		80.9	95	mA	
Supply Current Drivers Disabled and Receivers Enabled	I_{CCR}	$DE_- = \text{low}$, $RE_- = \text{low}$		22.7	30	mA	
Supply Current Drivers Disabled and Receivers Disabled	I_{CCZ}	$DE_- = \text{low}$, $RE_- = \text{high}$		22.7	30	mA	

Quad Bus LVDS Transceiver

AC ELECTRICAL CHARACTERISTICS

($V_{CC} = 3.0V$ to $3.6V$, $R_L = 27\Omega \pm 1\%$, differential input voltage $|V_{ID}| = 0.2V$ to V_{CC} , input frequency to LVDS inputs = $85MHz$, input frequency to LVCMOS/LVTTL inputs = $100MHz$, LVCMOS/LVTTL inputs = 0 to $3V$ with $2ns$ (10% to 90%) transition times. Differential input voltage transition time = $1ns$ (20% to 80%). Input common-mode voltage $V_{CM} = 1.2V$ to $1.8V$, $DE_- = high$, $RE_- = low$, $T_A = -40^\circ C$ to $+85^\circ C$, unless otherwise noted. Typical values are at $V_{CC} = 3.3V$, $|V_{ID}| = 0.2V$, $V_{CM} = 1.2V$, and $T_A = +25^\circ C$.) (Notes 3 and 5)

PARAMETER	SYMBOL	CONDITIONS	MIN	TYP	MAX	UNITS	
DRIVER							
Differential Propagation Delay High to Low	t_{PHLD}	$RE_- = high$, $C_L = 10pF$, Figures 3, 4	MAX9157EGJ	1.2	1.96	2.5	ns
			MAX9157EHJ	1.1	1.87	2.4	
Differential Propagation Delay Low to High	t_{PLHD}	$RE_- = high$, $C_L = 10pF$, Figures 3, 4	MAX9157EGJ	1.2	1.94	2.5	ns
			MAX9157EHJ	1.1	1.84	2.4	
Differential Skew $t_{PHLD} - t_{PLHD}$ (Note 6)	t_{SKD1}	$RE_- = high$, $C_L = 10pF$, Figures 3, 4		33	160	ps	
Channel-to-Channel Skew (Note 7)	t_{CCSK}	$RE_- = high$, $C_L = 10pF$, Figures 3, 4		58	300	ps	
Chip-to-Chip Skew (Note 8)	t_{SKD2}	$RE_- = high$, $C_L = 10pF$, Figures 3, 4		0.38	0.8	ns	
Chip-to-Chip Skew (Note 9)	t_{SKD3}	$RE_- = high$, $C_L = 10pF$, Figures 3, 4			1.3	ns	
Rise Time	t_{TLH}	$RE_- = high$, $C_L = 10pF$, Figures 3, 4	MAX9157EGJ	0.6	1.13	1.4	ns
			MAX9157EHJ	0.6	1.07	1.4	
Fall Time	t_{THL}	$RE_- = high$, $C_L = 10pF$, Figures 3, 4	MAX9157EGJ	0.6	1.16	1.4	ns
			MAX9157EHJ	0.6	1.11	1.4	
Disable Time High to Z	t_{PHZ}	$RE_- = high$, $C_L = 10pF$, Figures 5, 6	MAX9157EGJ		6.79	8	ns
			MAX9157EHJ		6.79	8	
Disable Time Low to Z	t_{PLZ}	$RE_- = high$, $C_L = 10pF$, Figures 5, 6	MAX9157EGJ		3.16	8	ns
			MAX9157EHJ		3.48	8	
Enable Time Z to High	t_{PZH}	$RE_- = high$, $C_L = 10pF$, Figures 5, 6	MAX9157EGJ		4.67	7	ns
			MAX9157EHJ		4.71	7	
Enable Time Z to Low	t_{PZL}	$RE_- = high$, $C_L = 10pF$, Figures 5, 6	MAX9157EGJ		4.36	7	ns
			MAX9157EHJ		4.39	7	
Maximum Operating Frequency (Note 10)	f_{MAX}	$RE_- = high$, $C_L = 10pF$, Figures 5, 6	100			MHz	
RECEIVER							
Differential Propagation Delay High to Low	t_{PHLD}	$DE_- = low$, Figures 7, 8; $C_L = 15pF$	MAX9157EGJ	1.8	2.58	4.1	ns
			MAX9157EHJ	1.8	2.61	4.1	
Differential Propagation Delay Low to High	t_{PLHD}	$DE_- = low$, Figures 7, 8; $C_L = 15pF$	MAX9157EGJ	1.8	2.49	4.1	ns
			MAX9157EHJ	1.8	2.52	4.1	
Differential Skew $t_{PHLD} - t_{PLHD}$ (Note 6)	t_{SKD1}	$DE_- = low$, Figures 7, 8; $C_L = 15pF$		90	450	ps	
Channel-to-Channel Skew (Note 7)	t_{CCSK}	$DE_- = low$, Figures 7, 8; $C_L = 15pF$		131	580	ps	
Chip-to-Chip Skew (Note 8)	t_{SKD2}	$DE_- = low$, Figures 7, 8; $C_L = 15pF$		0.7	1.7	ns	
Chip-to-Chip Skew (Note 9)	t_{SKD3}	$DE_- = low$, Figures 7, 8; $C_L = 15pF$		0.7	1.7	ns	
Rise Time	t_{TLH}	$DE_- = low$, Figures 7, 8; $C_L = 15pF$	0.5	1.1	1.6	ns	

Quad Bus LVDS Transceiver

MAX9157

AC ELECTRICAL CHARACTERISTICS (continued)

($V_{CC} = 3.0V$ to $3.6V$, $R_L = 27\Omega \pm 1\%$, differential input voltage $|V_{ID}| = 0.2V$ to V_{CC} , input frequency to LVDS inputs = $85MHz$, input frequency to LVCMOS/LVTTL inputs = $100MHz$, LVCMOS/LVTTL inputs = 0 to $3V$ with $2ns$ (10% to 90%) transition times. Differential input voltage transition time = $1ns$ (20% to 80%). Input common-mode voltage $V_{CM} = 1.2V$ to $1.8V$, DE_{-} = high, RE_{-} = low, $T_A = -40^{\circ}C$ to $+85^{\circ}C$, unless otherwise noted. Typical values are at $V_{CC} = 3.3V$, $|V_{ID}| = 0.2V$, $V_{CM} = 1.2V$, and $T_A = +25^{\circ}C$.) (Notes 3 and 5)

PARAMETER	SYMBOL	CONDITIONS	MIN	TYP	MAX	UNITS
Fall Time	t_{THL}	DE_{-} = low, Figures 7, 8; $C_L = 15pF$	0.7	1.2	1.8	ns
Disable Time High to Z	t_{PHZ}	DE_{-} = low, $R_L = 500\Omega$, $C_L = 15pF$, Figures 9, 10	MAX9157EGJ	6.74	8	ns
			MAX9157EHJ	6.82	8	
Disable Time Low to Z	t_{PLZ}	DE_{-} = low, $R_L = 500\Omega$, $C_L = 15pF$, Figures 9, 10	MAX9157EGJ	6.49	8	ns
			MAX9157EHJ	6.79	8	
Enable Time Z to High	t_{PZH}	DE_{-} = low, $R_L = 500\Omega$, $C_L = 15pF$, Figures 9, 10	MAX9157EGJ	4.67	7	ns
			MAX9157EHJ	4.57	7	
Enable Time Z to Low	t_{PZL}	DE_{-} = low, $R_L = 500\Omega$, $C_L = 15pF$, Figures 9, 10	MAX9157EGJ	5.43	7	ns
			MAX9157EHJ	4.71	7	
Maximum Operating Frequency (Note 10)	f_{MAX}	DE_{-} = low, $C_L = 15pF$	85			MHz

Note 1: Current into a pin is defined as positive. Current out of a pin is defined as negative. All voltages are referenced to ground except V_{TH} , V_{TL} , V_{ID} , V_{HYST} , V_{OD} , and ΔV_{OD} .

Note 2: Maximum and minimum limits over temperature are guaranteed by design and characterization. Devices are production tested at $T_A = +25^{\circ}C$.

Note 3: Guaranteed by design and characterization.

Note 4: Short only one output at a time. Do not exceed the absolute maximum junction temperature specification.

Note 5: C_L includes scope probe and test jig capacitance.

Note 6: t_{SKD1} is the magnitude difference of differential propagation delays in a channel. $t_{SKD1} = |t_{PHLD} - t_{PLHD}|$.

Note 7: t_{CCSK} is the magnitude difference of the t_{PLHD} or t_{PHLD} of one channel and the t_{PLHD} or t_{PHLD} of any other channel on the same part.

Note 8: t_{SKD2} is the magnitude difference of any differential propagation delays between parts operating over rated conditions at the same V_{CC} and within $5^{\circ}C$ of each other.

Note 9: t_{SKD3} is the magnitude difference of any differential propagation delays between parts operating over rated conditions.

Note 10: Meets data sheet specifications while operating at minimum f_{MAX} rating.

Typical Operating Characteristics

($V_{CC} = 3.3V$, $R_L = 27\Omega$, driver $C_L = 10pF$, receiver $C_L = 15pF$, $|V_{ID}| = 200mV$, $V_{CM} = 1.2V$, $f_{IN} = 20MHz$, $T_A = +25^{\circ}C$, unless otherwise noted.)

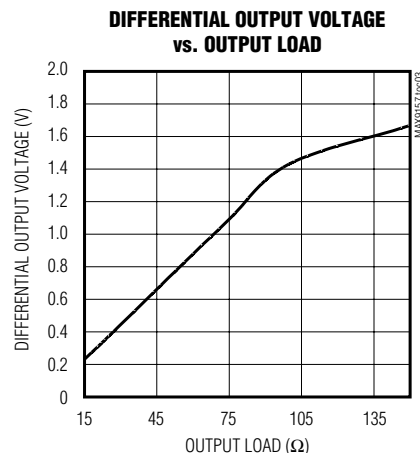
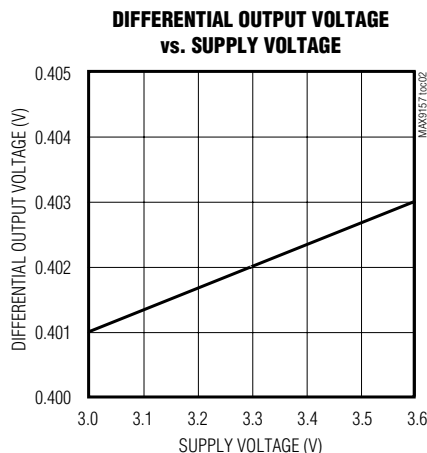
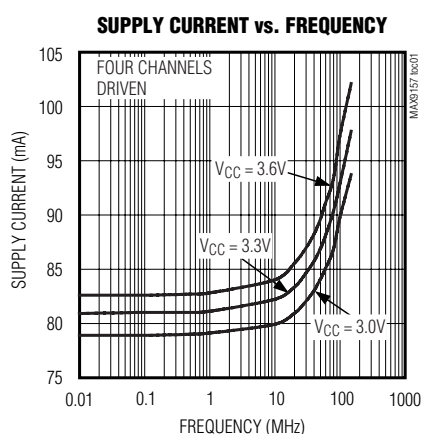

Quad Bus LVDS Transceiver

Typical Operating Characteristics (continued)

($V_{CC} = 3.3V$, $R_L = 27\Omega$, driver $C_L = 10pF$, receiver $C_L = 15pF$, $I_{ID1} = 200mV$, $V_{CM} = 1.2V$, $f_{IN} = 20MHz$, $T_A = +25^\circ C$, unless otherwise noted.)

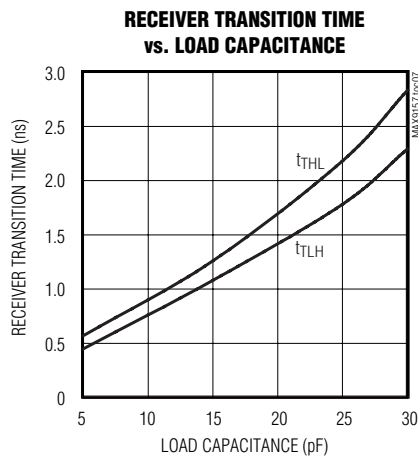
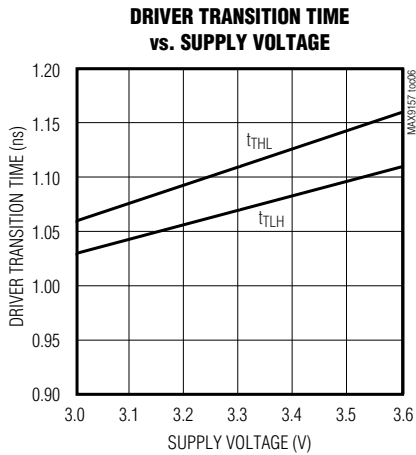
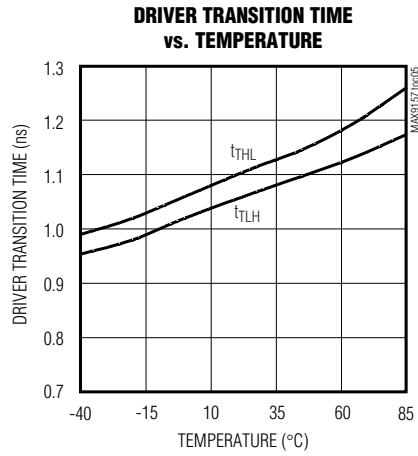
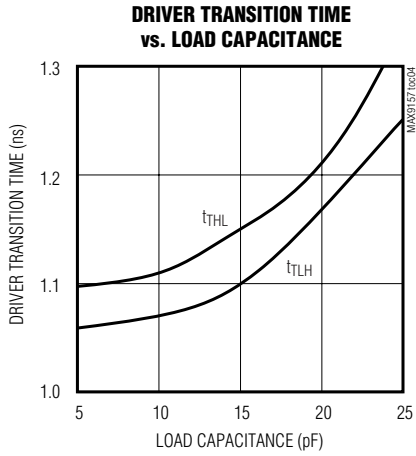

Quad Bus LVDS Transceiver

Pin Description

MAX9157

PIN	NAME	FUNCTION
1, 2, 22, 23, 24	N.C.	No Connection. Not internally connected.
3	VCC	Digital Power Supply
4, 21	GND	Digital Ground
5	$\overline{\text{RE34}}$	Receiver Channels 3 and 4 Enable (Enable Low). Drive RE34 low to enable receiver channels 3 and 4.
6	DE34	Driver Channels 3 and 4 Enable (Enable High). Drive DE34 high to enable driver channels 3 and 4.
7, 17	AGND	Analog Ground
8, 19	AVCC	Analog Power Supply
9	DO4-/RIN4-	Channel 4 Inverting BLVDS Input/Output
10	DO4+/RIN4+	Channel 4 Noninverting BLVDS Input/Output
11	DO3-/RIN3-	Channel 3 Inverting BLVDS Input/Output
12	DO3+/RIN3+	Channel 3 Noninverting BLVDS Input/Output
13	DO2-/RIN2-	Channel 2 Inverting BLVDS Input/Output
14	DO2+/RIN2+	Channel 2 Noninverting BLVDS Input/Output
15	DO1-/RIN1-	Channel 1 Inverting BLVDS Input/Output
16	DO1+/RIN1+	Channel 1 Noninverting BLVDS Input/Output
18	DE12	Driver Channels 1 and 2 Enable (Enable High). Drive DE12 high to enable driver channels 1 and 2.
20	$\overline{\text{RE12}}$	Receiver Channels 1 and 2 Enable (Enable Low). Drive RE12 low to enable receiver channels 1 and 2.
25	DIN1	Driver Channel 1 Input
26	RO1	Receiver Channel 1 Output
27	DIN2	Driver Channel 2 Input
28	RO2	Receiver Channel 2 Output
29	DIN3	Driver Channel 3 Input
30	RO3	Receiver Channel 3 Output
31	DIN4	Driver Channel 4 Input
32	RO4	Receiver Channel 4 Output
EP*	EXPOSED PAD	Exposed Pad. Solder exposed pad to GND.

*MAX9157EGJ only.

Quad Bus LVDS Transceiver

Detailed Description

The MAX9157 is a four-channel, 200Mbps, 3.3V BLVDS transceiver in 32-lead TQFP and QFN packages, ideal for driving heavily loaded multipoint buses, typically 16 to 20 cards plugged into a backplane. The MAX9157 receivers accept a differential input and have a fail-safe input circuit. The devices detect differential signals as low as 100mV and as high as V_{CC} .

The MAX9157 driver outputs use a current-steering configuration to generate a 9.25mA to 17mA output current. This current-steering approach induces less ground bounce and no shoot-through current, enhancing noise margin and system speed performance. The outputs are short-circuit current limited.

The MAX9157 current-steering output requires a resistive load to terminate the signal and complete the transmission loop. Because the devices switch the direction of current flow and not voltage levels, the output voltage swing is determined by the value of the termination resistor multiplied by the output current. With a typical 15mA output current, the MAX9157 produces a 405mV output voltage when driving a bus terminated with two 54 Ω resistors ($15\text{mA} \times 27\Omega = 405\text{mV}$). Logic states are determined by the direction of current flow through the termination resistor.

Fail-Safe Receiver Inputs

The fail-safe feature of the MAX9157 sets the output high when the differential input is:

- Open
- Undriven and shorted
- Undriven and terminated

Without a fail-safe circuit, when the input is undriven, noise at the input may switch the outputs and it may appear to the system that data is being sent. Open or undriven terminated input conditions can occur when a cable is disconnected or cut, or when driver output is in high impedance. A shorted input can occur because of a cable failure.

When the input is driven with a differential signal with a common-mode voltage of 0.05V to 2.4V, the fail-safe circuit is not activated. If the input is open, undriven and shorted, or undriven and parallel terminated, an internal resistor in the fail-safe circuit pulls both inputs above $V_{CC} - 0.3\text{V}$, activating the fail-safe circuit and forcing the outputs high (Figure 1).

Effect of Capacitive Loading

The characteristic impedance of a differential PC board trace is uniformly reduced when equal capacitive loads are attached at equal intervals (provided the transition time of the signal being driven on the trace is longer than the delay between loads). This kind of loading is typical of multipoint buses where cards are attached at 1in or 0.8in intervals along the length of a backplane.

The reduction in characteristic impedance is approximated by the following formula:

$$Z_{\text{DIFF-loaded}} = Z_{\text{DIFF-unloaded}} \times \text{SQRT} [C_o / (C_o + N \times C_L / L)]$$

where:

$Z_{\text{DIFF-unloaded}}$ = unloaded differential characteristic impedance

C_o = unloaded trace capacitance (pF/unit length)

C_L = value of each capacitive load (pF)

N = number of capacitive loads

L = trace length

For example, if $C_o = 2.5\text{pF/in}$, $C_L = 10\text{pF}$, $N = 18$, $L = 18\text{in}$, and $Z_{\text{DIFF-unloaded}} = 120\Omega$, the loaded differential impedance is:

$$\begin{aligned} Z_{\text{DIFF-loaded}} &= 120\Omega \times \\ &\text{SQRT} [2.5\text{pF} / (2.5\text{pF} + 18 \times 10\text{pF} / 18\text{in})] \\ Z_{\text{DIFF-loaded}} &= 54\Omega \end{aligned}$$

In this example, capacitive loading reduces the characteristic impedance from 120 Ω to 54 Ω . The load seen by

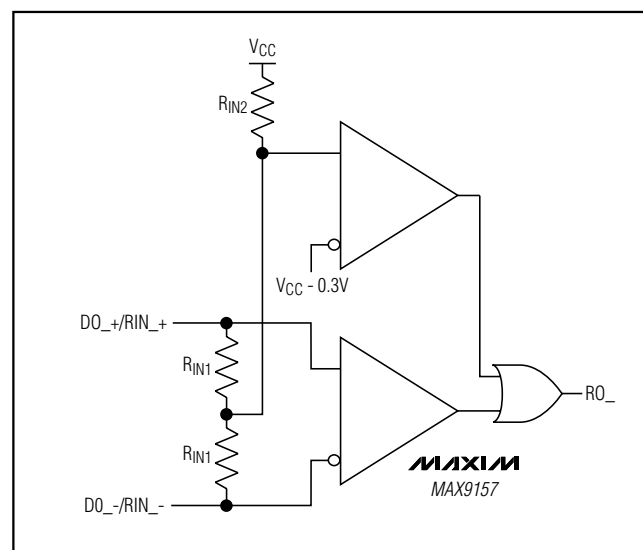

Figure 1. Internal Fail-Safe Circuit

Quad Bus LVDS Transceiver

a driver located on a card in the middle of the bus is 27Ω because the driver sees two 54Ω loads in parallel. A typical LVDS driver (rated for a 100Ω load) would not develop a large enough differential signal to be reliably detected by an LVDS receiver. The MAX9157 BLVDS drivers are designed and specified to drive a 27Ω load to differential voltage levels of 250mV to 460mV. A standard LVDS receiver is able to detect this level of differential signal. Short extensions off the bus, called stubs, contribute to capacitive loading. Keep stubs less than 1in for a good balance between ease of component placement and good signal integrity.

The MAX9157 driver outputs are current-source drivers and drive larger differential signal levels into loads lighter than 27Ω and smaller levels into loads heavier than 27Ω (see *Typical Operating Characteristics* curves). To keep loading from reducing bus impedance below the rated 27Ω load, PC board traces can be designed for higher unloaded characteristic impedance.

Effect of Transition Times

For transition times (measured from 0% to 100%) shorter than the delay between capacitive loads, the loads are seen as low-impedance discontinuities from which the driven signal is reflected. Reflections add and subtract from the signal being driven and cause decreased noise margin and jitter. The MAX9157 output drivers are designed for a minimum transition time of 1ns (rated 0.6ns from 20% to 80%, or about 1ns from 0% to 100%) to reduce reflections while being fast enough for high-speed backplane data transmission.

Power-On Reset

The power-on reset voltage of the MAX9157 is typically 2.25V. When the supply falls below this voltage, the devices are disabled and the receiver inputs/driver outputs are in high impedance. The power-on reset ensures glitch-free power-up and power-down, allowing hot swapping of cards in a multcard bus system without disrupting communications.

Receiver Input Hysteresis

The MAX9157 receiver inputs feature 52mV hysteresis to increase noise immunity for low-differential input signals.

Operating Modes

The MAX9157 features driver/receiver enable inputs that select the bus I/O function (Table 1). Tables 2 and 3 show the driver and receiver truth tables.

Input Internal Pullup/Pulldown Resistors

The MAX9157 includes pullup or pulldown resistors ($300k\Omega$) to ensure that unconnected inputs are defined (Table 4).

Applications Information

Supply Bypassing

Bypass each supply pin with high-frequency surface-mount ceramic 0.1 μ F and 1nF capacitors in parallel as close to the device as possible, with the smaller value capacitor closest to the device.

Termination

In the example given in the *Effect of Capacitive Loading* section, the loaded differential impedance of a bus is reduced to 54Ω . Since the bus can be driven from any card position, the bus must be terminated at each end. A parallel termination of 54Ω at each end of the bus placed across the traces that make up the differential pair provides a proper termination. The total load seen by the driver is 27Ω . The MAX9157 drives higher differential signal levels into lighter loads. (See Differential Output Voltage vs. Output Load graph in the *Typical Operating Characteristics* section). A multidrop bus with the driver at one end and receivers connected at regular intervals along the bus has a lowered impedance due to capacitive loading. Assuming a 54Ω impedance, the multidrop bus can be terminated with a single, parallel-connected 54Ω resistor at the far end from the driver. Only a single resistor is required because the driver sees one 54Ω differential trace. The signal swing is larger with a 54Ω load. In general, parallel terminate each end of the bus with a resistor

Table 1. I/O Enable Functional Table

MODE SELECTED	DE_	RE_
Driver Mode	H	H
Receiver Mode	L	L
High-Impedance Mode	L	H
Loopback Mode	H	L

Table 2. Driver Mode

INPUTS		OUTPUTS	
DE_	DIN_	DO_+/RIN_+	DO_-/RIN_-
H	L	L	H
H	H	H	L
L	X	Z	Z

Quad Bus LVDS Transceiver

Table 3. Receiver Mode

INPUTS		OUTPUTS
\overline{RE}_-	$V_{ID} = (V_{DO_+}/R_{IN_+}) - (V_{DO_ -}/R_{IN_ -})$	RO_-
L	$V_{ID} < -100mV$	L
L	$V_{ID} > 100mV$	H
L	Fail-safe operation guaranteed when DO_+/R_{IN_+} and $DO_-/R_{IN_ -}$ are open, undriven and shorted, or undriven and parallel terminated	H
H	X	Z

Table 4. Input Internal Pullup/Pulldown Resistors

PIN	INTERNAL RESISTOR
DE12	Pulldown to GND
DE34	Pulldown to GND
$\overline{RE}12$	Pullup to V_{CC}
$\overline{RE}34$	Pullup to V_{CC}
DIN_	Pullup to V_{CC}

matching the differential impedance of the bus (taking into account any reduced impedance due to loading).

Traces, Cables, and Connectors

The characteristics of input and output connections affect the performance of the MAX9157. Use controlled-impedance traces, cables, and connectors with matched characteristic impedance.

Ensure that noise couples as common mode by running the traces of a differential pair close together. Reduce within-pair skew by matching the electrical length of the traces of a differential pair. Excessive skew can result in a degradation of magnetic field cancellation. Maintain the distance between traces of a differential pair to avoid discontinuities in differential impedance. Minimize the number of vias to further prevent impedance discontinuities.

Avoid the use of unbalanced cables, such as ribbon cable. Balanced cables, such as twisted pair, offer superior signal quality and tend to generate less EMI due to canceling effects. Balanced cables tend to pick up noise as common mode, which is rejected by the receiver.

Board Layout

A four-layer PC board that provides separate power, ground, input, and output signals is recommended. Keep the LVTTTL/LVCMOS and BLVDS signals separated to prevent coupling.

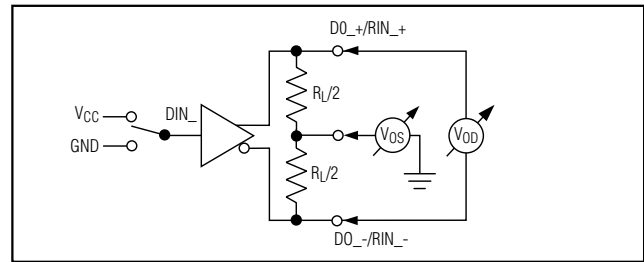

Figure 2. Driver V_{OD} and V_{OS} Test Circuit

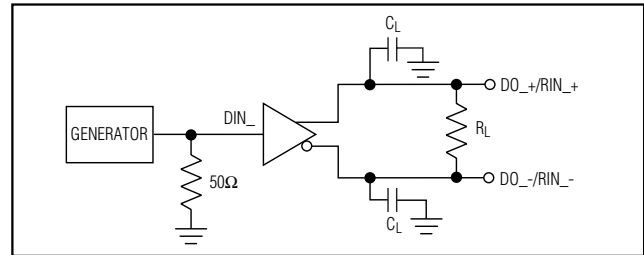

Figure 3. Driver Propagation Delay and Transition Time Test Circuit

Quad Bus LVDS Transceiver

MAX9157

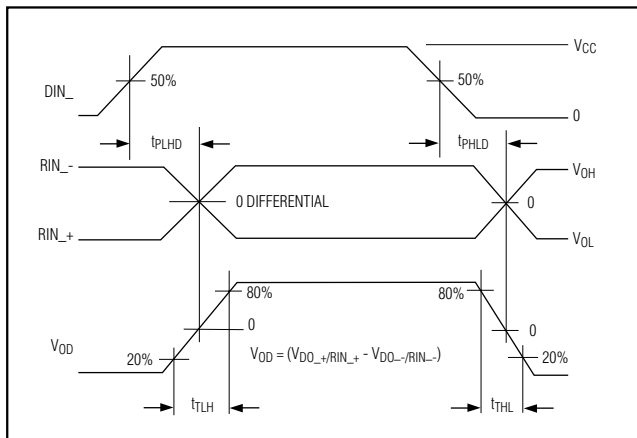

Figure 4. Driver Propagation Delay and Transition Time Waveforms

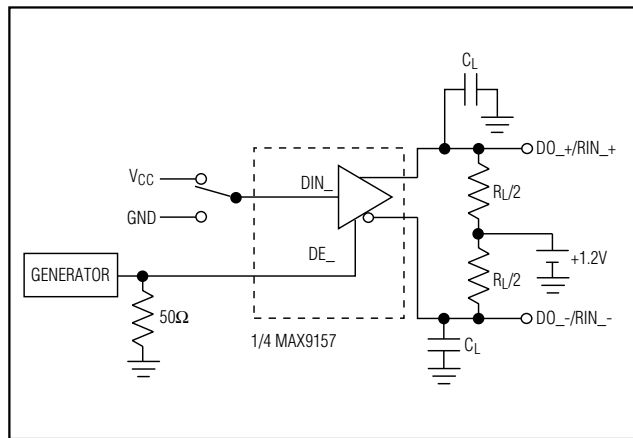

Figure 5. Driver High-Impedance Delay Test Circuit

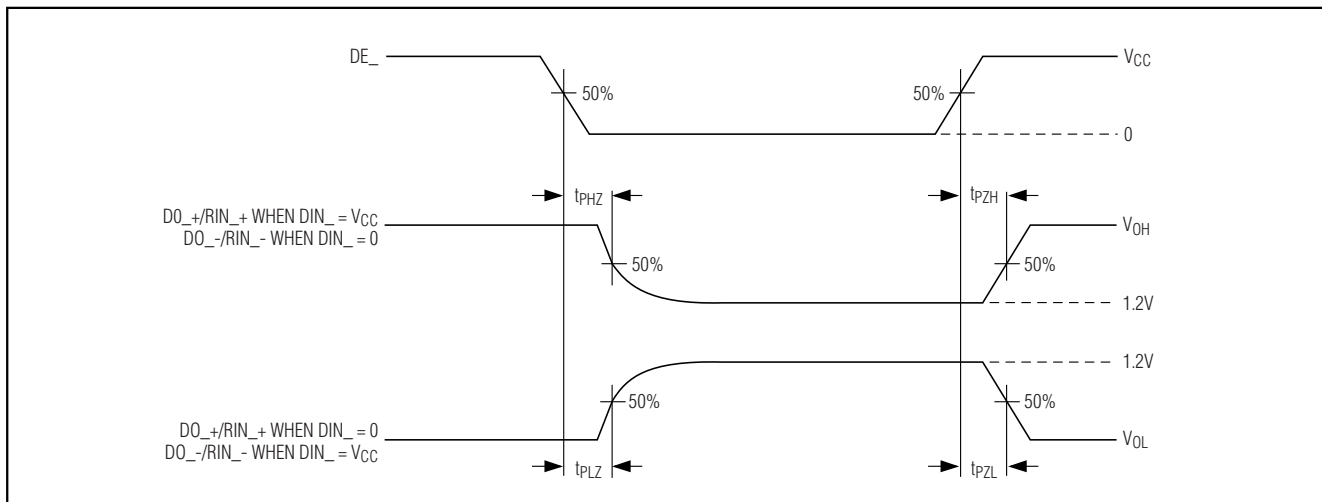

Figure 6. Driver High-Impedance Delay Waveform

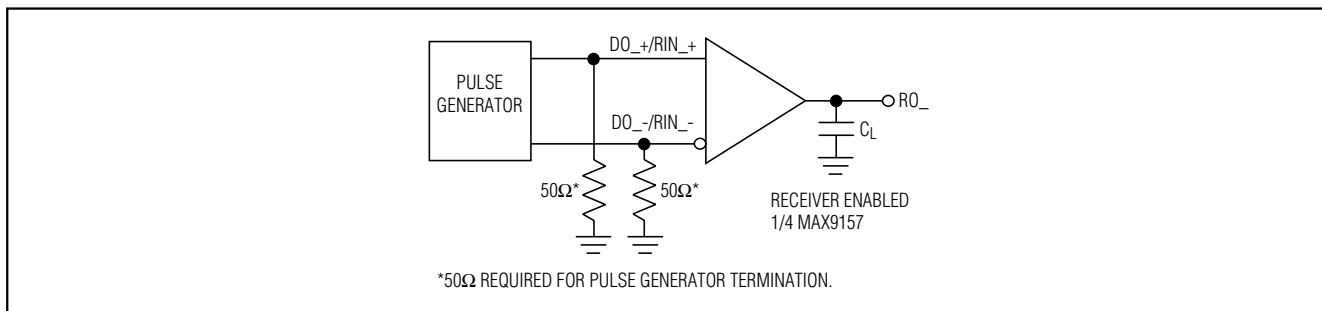

Figure 7. Receiver Transition Time and Propagation Delay Test Circuit

Quad Bus LVDS Transceiver

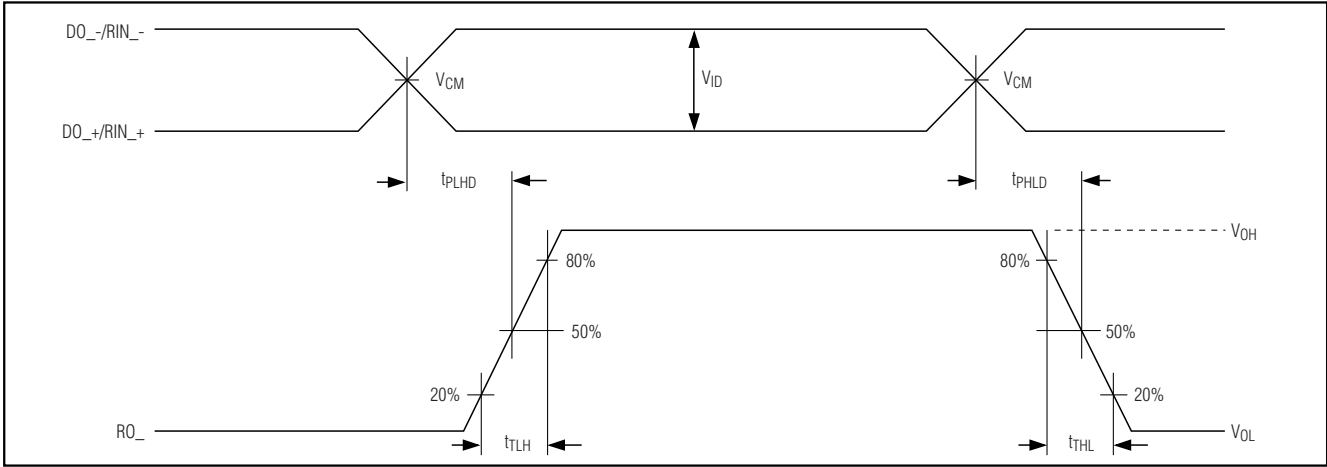

Figure 8. Receiver Transition Time and Propagation Delay Timing Diagram

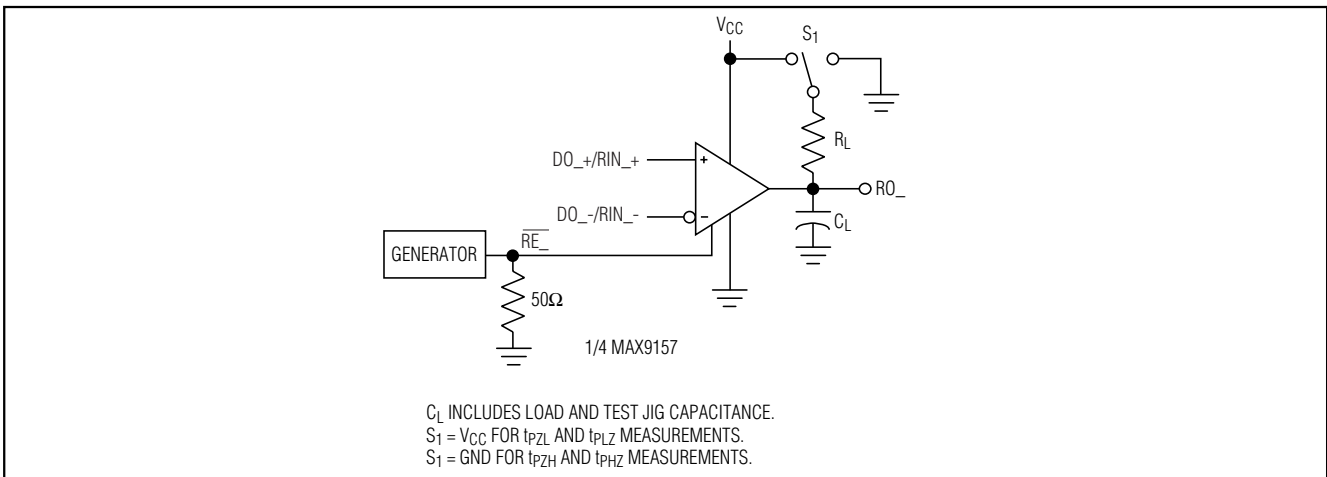

Figure 9. Receiver High-Impedance Delay Test Circuit

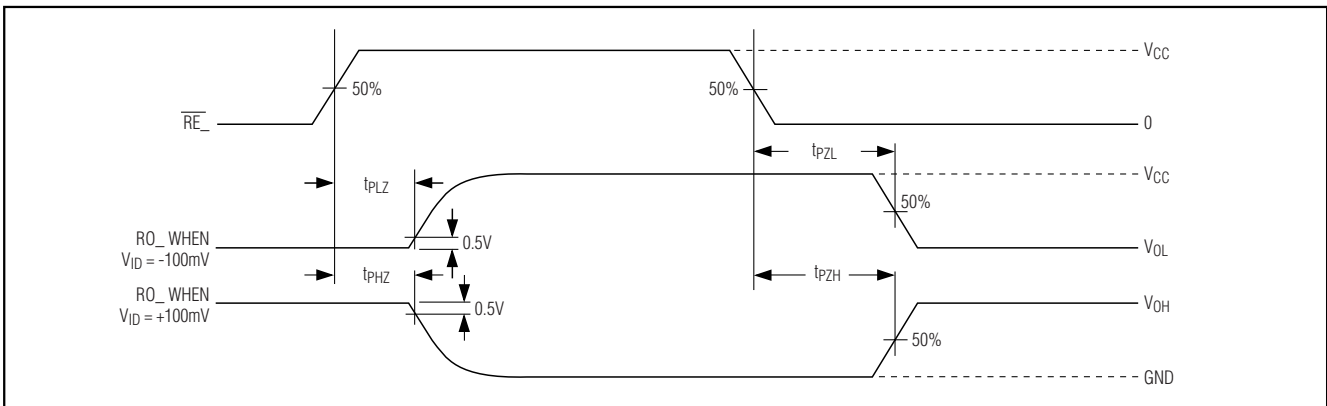
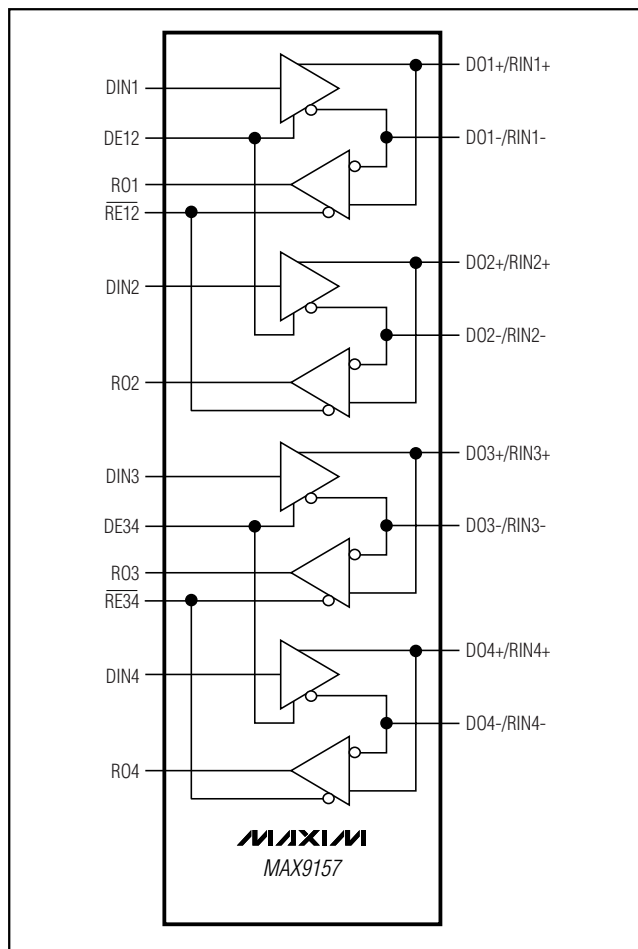

Figure 10. Receiver High-Impedance Waveforms

Quad Bus LVDS Transceiver

MAX9157

Functional Diagram



Pin Configurations

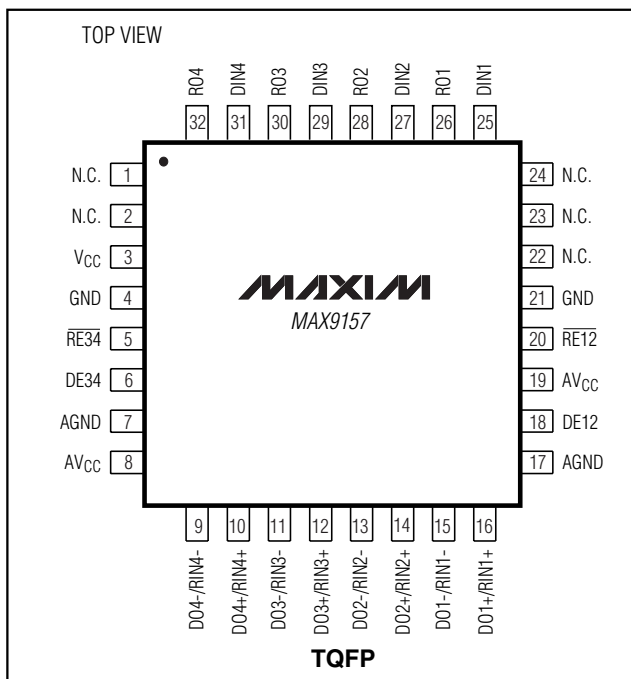

Chip Information

TRANSISTOR COUNT: 1826
 PROCESS: CMOS

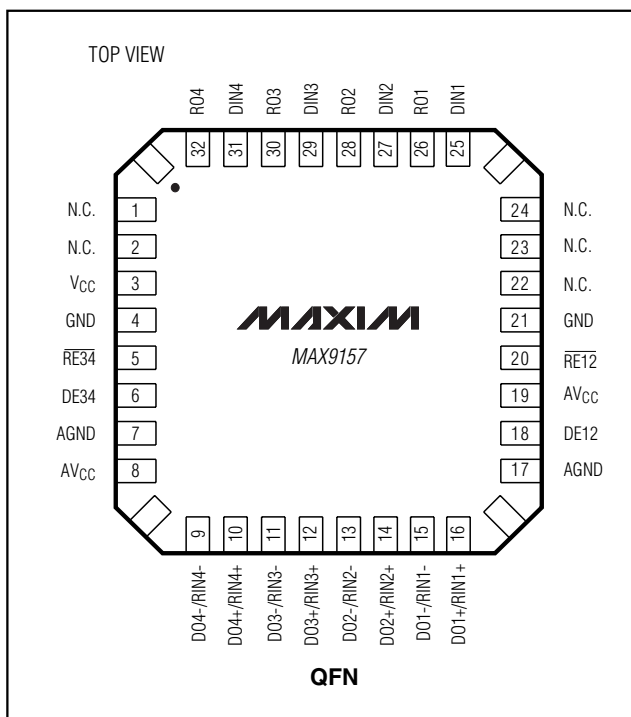

Quad Bus LVDS Transceiver

Package Information (continued)

MAX9157

NOTES:

1. DIE THICKNESS ALLOWABLE IS 0.305mm MAXIMUM (.012 INCHES MAXIMUM)
2. DIMENSIONING & TOLERANCES CONFORM TO ASME Y14.5M. - 1994.
3. N IS THE NUMBER OF TERMINALS.
Nd IS THE NUMBER OF TERMINALS IN X-DIRECTION &
Ne IS THE NUMBER OF TERMINALS IN Y-DIRECTION.
4. DIMENSION b APPLIES TO PLATED TERMINAL AND IS MEASURED BETWEEN 0.20 AND 0.25mm FROM TERMINAL TIP.
5. THE PIN #1 IDENTIFIER MUST BE EXISTED ON THE TOP SURFACE OF THE PACKAGE BY USING INDENTATION MARK OR INK/ LASER MARKED.
6. EXACT SHAPE AND SIZE OF THIS FEATURE IS OPTIONAL.
7. ALL DIMENSIONS ARE IN MILLIMETERS.
8. PACKAGE WARPAGE MAX 0.05mm.
9. APPLIED FOR EXPOSED PAD AND TERMINALS.
EXCLUDE EMBEDDED PART OF EXPOSED PAD FROM MEASURING.
10. MEETS JEDEC MO220.
11. THIS PACKAGE OUTLINE APPLIES TO ANVIL SINGULATION (STEPPED SIDES) AND TO SAW SINGULATION (STRAIGHT SIDES) QFN STYLES.

SYMBOL	COMMON DIMENSIONS			No. of Terminals
	MIN.	NOM.	MAX.	
A	0.80	0.90	1.00	
A1	0.00	0.01	0.05	
A2	0.00	0.65	1.00	
A3	0.20 REF.			
D	5.00 BSC			
D1	4.75 BSC			
E	5.00 BSC			
E1	4.75 BSC			
θ	0°	-	12°	
P	0		0.60	
D2	1.25	-	3.25	
E2	1.25	-	3.25	

PITCH VARIATION B				PITCH VARIATION B				PITCH VARIATION C				PITCH VARIATION D			
MIN. NOM. MAX.			No. of Terminals	MIN. NOM. MAX.			No. of Terminals	MIN. NOM. MAX.			No. of Terminals	MIN. NOM. MAX.			No. of Terminals
0.80 BSC			3	0.65 BSC			3	0.50 BSC			3	0.50 BSC			3
N	16		3	N	20		3	N	28		3	N	32		3
Nd	4		3	Nd	5		3	Nd	7		3	Nd	8		3
Ne	4		3	Ne	5		3	Ne	7		3	Ne	8		3
L	0.35	0.55	0.75	L	0.35	0.55	0.75	L	0.35	0.55	0.75	L	0.30	0.40	0.50
b	0.28	0.33	0.40	b	0.23	0.28	0.35	b	0.18	0.23	0.30	b	0.18	0.23	0.30



PROPRIETARY INFORMATION

TITLE:
PACKAGE OUTLINE, 16,20,28,32L QFN, 5x5x0.90 MM

APPROVAL	DOCUMENT CONTROL NO.	REV
	21-0091	G 2/2

Quad Bus LVDS Transceiver

Package Information (continued)

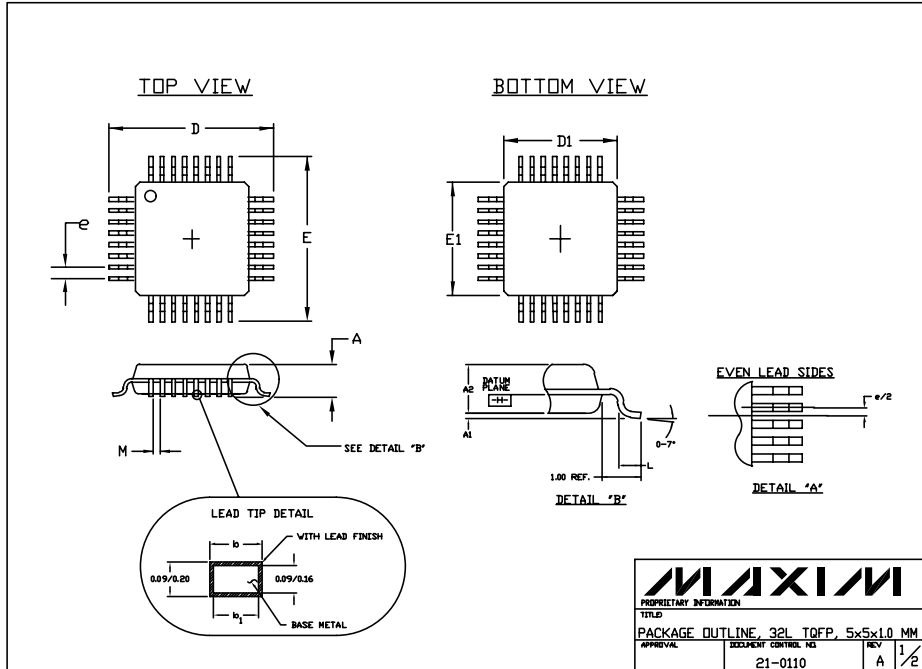

MAXIM
 PROPRIETARY INFORMATION
 TITLE: PACKAGE OUTLINE, 32L TOFP, 5x5x1.0 MM
 APPROVAL: _____ DOCUMENT CONTROL NO: 21-0110 REV: A 1/2

NOTES:

- ALL DIMENSIONING AND TOLERANCING CONFORM TO ANSI Y14.5-1982.
- DATUM PLANE "E1" IS LOCATED AT MOLD PARTING LINE AND COINCIDENT WITH LEAD, WHERE LEAD EXITS PLASTIC BODY AT BOTTOM OF PARTING LINE.
- DIMENSIONS D1 AND E1 DO NOT INCLUDE MOLD PROTRUSION. ALLOWABLE MOLD PROTRUSION IS 0.254 MM ON D1 AND E1 DIMENSIONS.
- THE TOP OF PACKAGE IS SMALLER THAN THE BOTTOM OF PACKAGE BY 0.15 MILLIMETERS.
- DIMENSION b DOES NOT INCLUDE DAMBAR PROTRUSION. ALLOWABLE DAMBAR PROTRUSION SHALL BE 0.08 MM TOTAL IN EXCESS OF THE b DIMENSION AT MAXIMUM MATERIAL CONDITION.
- CONTROLLING DIMENSION: MILLIMETER.
- THIS OUTLINE CONFORMS TO JEDEC PUBLICATION 95, REGISTRATION MO-136.
- LEADS SHALL BE COPLANAR WITHIN .004 INCH.

JEDEC VARIATIONS	
DIMENSIONS IN MILLIMETERS	
AA	
5x5x1.0 MM	
MIN. MAX.	
A	~ 1.20
A1	0.05 0.15
A2	0.95 1.05
D	7.00 BSC.
D1	5.00 BSC.
E	7.00 BSC.
E1	5.00 BSC.
L	0.45 0.75
M	0.15 ~
N	32
e	0.50 BSC.
b	0.17 0.27
b1	0.17 0.23

MAXIM
 PROPRIETARY INFORMATION
 TITLE: PACKAGE OUTLINE, 32L TOFP, 5x5x1.0 MM
 APPROVAL: _____ DOCUMENT CONTROL NO: 21-0110 REV: A 2/2

Maxim cannot assume responsibility for use of any circuitry other than circuitry entirely embodied in a Maxim product. No circuit patent licenses are implied. Maxim reserves the right to change the circuitry and specifications without notice at any time.

Maxim Integrated Products, 120 San Gabriel Drive, Sunnyvale, CA 94086 408-737-7600 _____ 16

Looking for pricing, stock, or lifecycle information?

Click below to explore more details on WIN SOURCE:

 [View MAX9157EHJ+T on WIN SOURCE](#)

 [Maxim Integrated](#) Information

Optimize Your Supply Chain with WIN SOURCE Solutions

-  Global Sourcing Solution
-  Obsolete Management
-  Cost Control Management
-  Shortage Management
-  Alternative Solution
-  Excess Inventory Management